

**ARROW III - TURBO ARROW III
ARROW**

SERVICE MANUAL

CARD 1 OF 3

PA-28R-201/201T

PIPER AIRCRAFT CORPORATION

**Courtesy of Bomar Flying Service
www.bomar.biz**

(PART NUMBER 761 639)

1A1

CHEROKEE ARROW III SERVICE MANUAL

AEROFICHE EXPLANATION AND REVISION STATUS

Service manual information incorporated in this set of Aerofiche cards is arranged in accordance with the general specifications of Aerofiche adopted by the General Aviation Manufacturer's Association. Information compiled in this Aerofiche service manual is kept current by revisions distributed periodically. These revisions supersede all previous revisions, are complete Aerofiche card replacements, and supersede Aerofiche cards of the same number in the set.

Identification of revised material:

Revised text and illustrations are indicated by a black vertical line along the left-hand margin of the frame, opposite revised or added material. Revision lines indicate only current revisions with changes and additions to existing text and illustrations. Changes in capitalization, spelling, punctuation, indexing, the physical location of the material, or complete page additions are not identified by revision lines.

Revisions to Service Manual 761-639 issued December 15, 1976 are as follows:

Effectivity	Publication Date	Aerofiche Card Effectivity
ORG761215	December 15, 1976	1 and 2
PR770831	August 31, 1977	1 and 2
PR781211	December 11, 1978	1 and 2
PR800501	May 1, 1980	1 and 2
PR801121	November 21, 1980	1 and 2
PR810713	July 13, 1981	1 and 2
PR831018	October 18, 1983	1 and 2
IR860730	July 30, 1986	1
IR860920	September 20, 1986	1
IR870506	July 12, 1987	1
PR890213	August 1, 1989	1, 2 and 3
IR950221	February 21, 1995	1 and 2
IR040227*	February 27, 2004	1 and 2

***INTERIM CHANGE TO SERVICE MANUAL 761-639**

Section VII in Card 1 and Sections VIII and VIIIA in Card 2 have been revised. There are no other changes included in this interim change revision. Please discard your current cards 1 and 2, and replace them with the revised ones. DO NOT DISCARD CARD 3.

Consult the latest Customer Services Information Aerofiche for current revision dates for this manual.

TABLE OF CONTENTS

NO.	AEROFICHE CARD NO. 1	GRID NO.
I	INTRODUCTION	1A13
II	HANDLING AND SERVICING	1A16
III	INSPECTION	1D1
IV	STRUCTURES	1D17
V	SURFACE CONTROLS	1F6
VI	HYDRAULIC SYSTEM	1H5
VII	LANDING GEAR AND BRAKE SYSTEM	1I22
AEROFICHE CARD NO. 2		
VIII	POWER PLANT (CONTINENTAL)	2A9
VIIIA	POWER PLANT (LYCOMING)	2C18
IX	FUEL SYSTEM	2E8
X	INSTRUMENTS	2F5
XI	ELECTRICAL SYSTEM	2G15
XII	ELECTRONICS	2J19
XIII	HEATING AND VENTILATING	2K5
AEROFICHE CARD NO. 3		
XIV	ACCESSORIES AND UTILITIES	3A5

THIS PAGE INTENTIONALLY LEFT BLANK

LIST OF ILLUSTRATIONS

Figure		Aerofiche Grid No.
2-1.	Three View of PA-28R-201T.....	1A19
2-2.	Three View of PA-28R-201.....	1A20
2-3.	Station Reference Lines of PA-28R-201T.....	1A21
2-4.	Station Reference Lines of PA-28R-201.....	1A22
2-5.	Access Plates and Panels.....	1A23
2-6.	Jacking Arrangement.....	1B8
2-7.	Weighing Arrangement.....	1B8
2-8.	Leveling Longitudinally.....	1B9
2-9.	Leveling Laterally.....	1B9
2-10.	Service Points (PA-28R-201).....	1B14
2-11.	Service Points (PA-28R-201T).....	1B15
2-12.	Fuel Strainer.....	1B20
2-13.	Lubrication Chart (Landing Gear, Main).....	1C14
2-14.	Lubrication Chart (Landing Gear, Nose).....	1C15
2-15.	Lubrication Chart (Control System).....	1C16
2-16.	Lubrication Chart (Control System) (cont).....	1C17
2-17.	Lubrication Chart (Control System) (cont).....	1C18
2-18.	Lubrication Chart (Control System) (cont).....	1C19
2-19.	Lubrication Chart (Cabin Door, Baggage Door and Seat).....	1C20
2-20.	Lubrication Chart (Lycoming Power Plant, Propeller and Control Pivot Points).....	1C21
2-21.	Lubrication Chart (Continental Power Plant, Propeller and Control Pivot Points).....	1C22
2-22.	Lubrication Chart (Back-Up Extender).....	1C23
2-23.	Lubrication Chart (Air Conditioning Condenser).....	1C24
4-1.	Aileron and Flap Installation.....	1D21
4-2.	Wing Installation.....	1D22
4-3.	Methods of Securing Control Cables.....	1E2
4-4.	Empennage Group Installation.....	1E5
4-5.	Windshield Installation (Typical).....	1E8
4-6.	Side Window Installation (Typical).....	1E10
4-7.	Skin Materials and Thickness.....	1E11
4-7a.	Door Seal Snubber Installation.....	1E14
4-8.	Fabricated Tool for Baggage Door Lock.....	1E15
4-8a.	Baggage Compartment Inspection Holes Cutout Details.....	1E16
4-9.	Control Surface Balance Tool.....	1E21
4-10.	Aileron Balancing.....	1E22
4-11.	Rudder Balancing.....	1E23
4-12.	Rudder Balance Weight.....	1E24
4-13.	Stabilator Balancing.....	1F1
4-14.	Removal of Cherrylock Rivet.....	1F3
4-15.	Identification of Aircraft Fluid Lines.....	1F4
4-16.	Torque Wrench Formula.....	1F5
5-1.	Control Column Assembly.....	1F11
5-1a.	Correct Method of Installing Rod End Bearings.....	1F12
5-2.	Aileron Controls.....	1F15
5-3.	Bellcrank Rigging Tool.....	1F18
5-4.	Aileron Rigging Tool.....	1F20
5-5.	Stabilator Rigging Tool.....	1F20
5-6.	Stabilator Controls.....	1F22
5-7.	Methods of Securing Trim Cables.....	1F24

LIST OF ILLUSTRATIONS (cont)

Figure		Aerofiche Grid No.
7-20.	Installation of Anchor Bolt.....	1K16
7-21.	Brake System Installation.....	1K18
7-22.	Brake Master Cylinder (Hand/Parking Brake).....	1K19
7-23.	Toe Brake Installation.....	1K20
7-24.	Brake Cylinder (1700) (Toe Brake).....	1K21
7-25.	Brake Cylinder (10-27) (Toe Brake).....	1K21
7-26.	Bleeding Brakes.....	1L1
7-27.	Nose Gear Service Tolerances.....	1L9
7-28.	Main Gear Service Tolerances.....	1L12
8-1.	Engine Cowling Installation.....	2A13
8-3.	Propeller Installation	2A14
8-4.	Propeller Blade Minor Repair	2A16
8-5.	Propeller Governor.....	2A17
8-6.	Engine Installation.....	2A20
8-7.	Schematic Diagram of Turbocharger System.....	2A23
8-8.	Induction System Installation.....	2B5
8-8a.	Magneto Assembly.....	2B7
8-9.	Contact Spring Inspection	2B8
8-10.	Contact Points.....	2B9
8-11.	Impulse Coupling	2B10
8-12.	Flyweight Clearance of Impulse Coupling.....	2B10
8-13.	Rotor Holding Tool Installed.....	2B11
8-14.	Timing Kit Installed.....	2B11
8-15.	Cast-In Timing Marks.....	2B12
8-16.	Fabricated Pointer.....	2B12
8-17.	Engine Timing Marks.....	2B13
8-18.	Removing Spring From Lead Assembly.....	2B15
8-19.	Assembly Tool.....	2B17
8-20.	Assembly Tool Application.....	2B17
8-21.	Measuring Lead Assembly Length.....	2B17
8-22.	Ferrule Seating Tool	2B19
8-23.	Measuring Wire From Top of Ferrule	2B19
8-24.	Needle.....	2B19
8-25.	Installing Grommet Over Lead Assemblies.....	2B19
8-26.	Lead Assembly Installed in Grommet.....	2B20
8-27.	Wire Doubled Over For Installation of Eyelet	2B20
8-28.	Ignition Schematic.....	2B21
8-29.	Removing Frozen Spark Plug.....	2B23
8-30.	Lubrication System Maintenance Points.....	2B24
8-31.	Schematic Diagram of Fuel Injection System.....	2C2
8-32.	Fuel Injection Nozzle Assembly	2C3
8-33.	Engine Controls.....	2C4
8-34.	Idle Speed and Mixture Adjustment Points.....	2C6
8-35.	Sectional View of Altitude Compensating Fuel Pump Assembly.....	2C8
8-36.	Exhaust Bypass Screw.....	2C10
8A-1.	Propeller Installation (Hartzell).....	2C21
8A-2.	Propeller Blade Minor Repair	2C22
8A-3.	Propeller Governor.....	2C24
8A-3a.	Engine Cowling Installation.....	2D2
8A-4.	Engine Installation (PA-28R-201).....	2D4
8A-4a.	Adjustment of Engine Controls.....	2D7
8A-5.	Fuel Injector.....	2D8
8A-6.	Schematic Diagram of RSA Injector System.....	2D9

LIST OF ILLUSTRATIONS (CONT)

Figure		Aerofiche Grid No.
8A-7.	Fuel-Air Bleed Nozzle.....	2D11
8A-8.	Contact Points.....	2D13
8A-9.	Rotor Holding Tool Installed.....	2D14
8A-10.	Timing Kit Installed.....	2D14
8A-11.	Aligning Timing Marks.....	2D15
8A-12.	Checking Flyweight Clearance of Impulse Coupling	2D15
8A-13.	Engine Timing Marks.....	2D17
8A-14.	Magneto Adjustment Limits.....	2D17
8A-15.	Magneto Timing Mark.....	2D18
8A-16.	Removing Spring From Lead Assembly.....	2D18
8A-17.	Assembly Tool.....	2D19
8A-18.	Using Assembly Tool	2D19
8A-19.	Measuring Lead Assembly Length.....	2D19
8A-20.	Cutting Metallic Braid From End of Lead	2D21
8A-21.	Unbraiding Metallic Shielding.....	2D21
8A-22.	Forming Shielding Around Ferrule.....	2D21
8A-23.	Ferrule Seating Tool	2D21
8A-24.	Needle.....	2D21
8A-25.	Measuring Wire From Top of Ferrule	2D23
8A-26.	Installing Grommet Over Lead Assemblies	2D23
8A-27.	Lead Assembly Installed in Grommet.....	2D23
8A-28.	Wire Doubled Over For Installation of Eyelet	2D23
8A-29.	Removing Spark Plug Frozen to Bushing	2E1
9-1.	Fuel System Diagram (PA-28R-201).....	2E11
9-1a.	Fuel System Diagram (PA-28R-201 S/N's 37001 and up).....	2E12
9-2.	Fuel System Diagram (PA-28R-201T).....	2E13
9-3.	Fuel Sender Units Installation.....	2E15
9-4.	Engine Primer System Placard.....	2E16
9-5.	Fuel Quantity Indicator.....	2E19
9-6.	Fuel Filter Bowl and Screen.....	2E20
9-7.	Fuel Pump Variable Resistor.....	2E21
9-8.	Tolerance, Union Nut and Tubing.....	2F2
10-1.	Instrument Panel (Typical).....	2F11
10-1a.	Instrument Panel(PA-28R-201 S/N's 2837001 and up).....	2F12
10-1b.	Instrument Panel (PA-28R-201T S/N's 2803001 and up).....	2F13
10-2.	Pitot Static System.....	2F14
10-3.	Vacuum-Auxiliary Vacuum System	2F16
11-2.	Lamp-Bank Load.....	2G20
11-3.	Checking Field Circuit	2G21
11-4.	Testing Field Circuit.....	2G21
11-5.	Testing Rectifiers (Positive).....	2G22
11-6.	Testing Rectifiers (Negative).....	2G23
11-7.	C-3928 Fixtures and Adapters.....	2G24
11-8.	Removing Rectifiers.....	2G24
11-9.	Installing Rectifiers	2H1
11-10.	Soldering Rectifiers Lead.....	2H2
11-11.	Testing Stator Coils	2H3
11-12.	Removing End Bearing	2H4

LIST OF ILLUSTRATIONS (CONT)

Figure		Aerofiche Grid No.
11-13.	Installing End Bearing.....	2H4
11-14.	Removing Drive Pulley.....	2H5
11-15.	Removing Drive End Bealing	2H5
11-16.	Removing Slip Ring.....	2H6
11-17.	Installing Slip Ring.....	2H6
11-18.	Solder Points.....	2H7
11-19.	Installing Retainer	2H7
11-20.	Installing Drive End Shield and Bearing (Typical).....	2H8
11-21.	Installing Pulley.....	2H8
11-22.	Meter Connections for Alternator Performance Test	2H10
11-23.	Exploded View of Prestolite Alternator.....	2H12
11-24.	Removal of Slip Ring End Bearing.....	2H13
11-25.	Removal of Rectifier	2H13
11-26.	Removal of Drive End Head (PA-28R-201 only).....	2H14
11-27.	Removal of End Head Bearing (Typical).....	2H14
11-28.	Testing Rotor for Ground	2H15
11-29.	Testing Rotor for Shorts	2H15
11-30.	Installation of Drive End Head.....	2H16
11-31.	Installation of Rectifier.....	2H16
11-32.	Temminal Assembly.....	2H17
11-33.	Slip Ring End Bearing Assembly.....	2H18
11-34.	Testing Alternator.....	2H18
11-35.	Brush Installation.....	2H19
11-36.	Internal Wiring Diagram.....	2H19
11-37.	Exploded View of Gear Reduction Starting Motor (PA-28R-201)	2H21
11-38.	Exploded View of Starting Motor (PA-28R-201T).....	2H22
11-39.	Tuning Starting Motor Commutator.....	2H23
11-40.	Testing Motor Armature for Shorts.....	2H23
11-41.	Testing Motor Fields for Grounds.....	2H24
11-42.	No-Load Test Hook-Up.....	2H24
11-43.	Stall-Torque Hook-Up.....	2I1
11-44.	Strobe Light Connections (Earlier Models)	2I7
11-44a.	Strobe Light Connections (Later Models).....	2I8
11-44b.	Ignition Switch	2I12
11-45.	Temminal Block	2I13

NOTE: (Electrical Schematics Figures 11-46 thru 11-67, see Table XI-VIII.)

12-1.	ELT Schematic Typical.....	2K3
12-2.	ELT Portable Folding Antenna (Narco)	2K4
12-3.	ELT Using Fixed Aircraft Antenna (Narco).....	2K4
13-1.	Cabin Heater and Defroster (PA-28R-201)	2K7
13-2.	Cabin Heater and Defroster (PA-28R-201T).....	2K8
13-3.	Ovemead Vent System and Fresh Air System.....	2K9

LIST OF ILLUSTRATIONS (CONT)

Figure		Aerofiche Grid No.
14-1.	Air Conditioning System Installation.....	3A8
14-2.	Service Valves	3A12
14-3.	Test Gauge and Manifold Set	3A13
14-4.	Manifold Set Operation.....	3A14
14-5.	Leak Test Hook-Up	3A15
14-6.	Evacuation Hook-Up.....	3A17
14-7.	Charging Stand.....	3A19
14-8.	Charging Hook-Up.....	3A20
14-8a.	Top Dead Center Casting Mark (Sankyo Compressor).....	3B1
14-8b.	Rotation of Clutch Front Plate (Sankyo Compressor Oil Check)	3B1
14-9.	York Compressor and Fabricated Oil Dipstick (PA-28R-201).....	3B2
14-9a.	Compressor and Alternator Belt Installation.....	3B3
14-10.	Magnetic Clutch (York Compressor).....	3B6
14-11.	Condenser Air Scoop Installation.....	3B9
14-12.	Expansion Valve.....	3B10
14-13.	Components Installation.....	3B11
14-14.	Adjustment of Air Conditioning Throttle Switch (PA-28R-201).....	3B13
14-15.	Air Conditioning Wiring Schematic.....	3B14
14-16.	Oxygen Installation	3C2
14-17.	Test Apparatus for Testing Oxygen System.....	3C3
14-18.	Oxygen Tubing Installations.....	3C4
14-19.	Installation of Swageloc Fittings.....	3C7
14-20.	Portable Oxygen Installation.....	3C14

LIST OF TABLES

Table		Aerofiche Grid No.
II-I.	Leading Particulars and Principal Dimensions.....	1A24
II-II.	Recommended Torques	1B3
II-III	Recommended Engine Lubrication Oils	1C2
II-IV	Thread Lubricant.....	1C3
II-V	Conversion Tables	1C4
II-VI	Lubrication Specification	1C10
III-I	Inspection Report.....	1D5
IV-I	Balance Specifications.....	1E24
IV-II	Maximum Distance Between Supports For Fluid Tubing.....	1F2
IV-III	Hose Clamps Tightening (Initial Installation).....	1F2
V-I	Control Surface Travel and Cable Tension.....	1F8
V-II	Cable Tension Vs. Ambient Temperature.....	1F10
V-III	Troubleshooting Chart (Surface Controls)	1G20
VI-I	Leading Particulars, Hydraulic System.....	1H12
VI-II	Characteristics, Hydraulic Pump Motor.....	1H18
VI-III	Hydraulic System Troubleshooting.....	1I10
VII-I	Toe-In-Toe-Out Correction Chart.....	1K4
VII-II	Troubleshooting Chart (Landing Gear).....	1L2
VII-III	Nose Gear Service Tolerances.....	1L10
VII-IV	Main Gear Service Tolerances.....	1L13

LIST OF TABLES

Table	Aerofiche Grid No.
VIII-I. Propeller Specifications.....	2A16
VIII-II. Engine Data.....	2A21
VIII-III. Troubleshooting Chart (Engine).....	2C12
VIIIA-I. Propeller Specifications.....	2D1
VIIIA-II. Engine Troubleshooting.....	2E3
IX-I. Fuel Sender Locations.....	2E16
IX-II. Fuel Quantity Transmitter Calibration Tolerances.....	2E18
IX-III. Transmitter Fuel Gauge Tolerances.....	2E23
IX-IV. Troubleshooting Chart (Fuel System)	2F3
X-I. Vacuum System.....	2F19
X-II. Directional Gyro Indicator	2F21
X-III. Gyro Horizon Indicator	2F22
X-IV. Rate of Climb Indicator.....	2F24
X-V. Altimeter.....	2G1
X-VI. Airspeed Tubes and Indicator.....	2G3
X-VII. Magnetic Compass	2G5
X-VIII. Manifold Pressure Indicator.....	2G6
X-IX. Tachometer	2G7
X-X. Engine Oil Pressure Gauge.....	2G8
X-XI. Fuel Pressure Gauge.....	2G9
X-XII. Tum and Bank Indicator.....	2G10
X-XIII. Fuel Quantity Indicators.....	2G11
X-XIV. Oil Temperature Indicators.....	2G12
X-XV. Cylinder Head Temperature Gauge.....	2G14
XI-I. Alternator Belt Tension	2H10
XI-II. Alternator Specifications.....	2H18
XI-III. Starting Motor Service Test Specifications.....	2I3
XI-IV. Hydrometer Reading and Battery Charge Percent	2I4
XI-V. Electrical System Troubleshooting.....	2I14
XI-VI. Electrical Symbols.....	2J4
XI-VII. Electrical Wire Coding.....	2J5
XI-VIII. Index-Electrical System Schematics	2J6
XIV-I. Temperature Pressure Chart.....	3A9
XIV-II. Aluminum Tubing Torque.....	3A12
XIV-III. Compressor Oil Charge.....	3A24
XIV-IV. Troubleshooting Chart (Air Conditioner).....	3B16
XIV-V. Blower System Wire Color Codes.....	3B23
XIV-VI. Oxygen System Component Limits.....	3C15
XIV-VII. Troubleshooting Chart (Oxygen System).....	3C17

LIST OF CHARTS

Chart	Aerofiche Grid No.
VIII-I. Metered Fuel Assembly Calibration.....	2C10
VIII-II. Limits-Fuel Flow Vs. Brake H.P.	2C11
VIII-III. Oxygen System Limits	3C8
VIII-IV. Filling Pressure for Certain Ambient Temperatures.....	3C13

THIS PAGE INTENTIONALLY LEFT BLANK

SECTION I

INTRODUCTION

Paragraph		Aerofiche Grid No.
1-1.	General	1A14
1-2.	Scope of Manual.....	1A14
1-3.	Description	1A14
1-4.	Wing	1A14
1-5.	Empennage	1A14
1-6.	Fuselage.....	1A14
1-7.	Landing Gear.....	1A14
1-8.	Hydraulic System	1A15
1-9.	Brake System.....	1A15
1-10.	Engine.....	1A15
1-11.	Propeller	1A15
1-12.	Fuel System	1A15
1-13.	Flight Controls.....	1A15
1-14.	Cabin Heater, Defroster and Fresh Air System.....	1A15
1-15.	Radio.....	1A15
1-16.	Instrument and Autopilot System.....	1A15

CHEROKEE ARROW III SERVICE MANUAL

SECTION I

INTRODUCTION

1-1. GENERAL. This manual contains service and maintenance procedures for the PA-28R-201T, 28R-201 Cherokee aircraft, designed and manufactured as a versatile airplane for use in the personal and business aviation field, by the Piper Aircraft Corporation.

1-2. SCOPE OF MANUAL. Section II comprise the routine service part of this manual, Section III covers inspections, and Sections IV through XIV comprise maintenance instructions. The routine service instructions include ground handling and routine servicing. The inspection section includes 50, 100, 500, and 1000 hour inspections which the manufacture requires for this airplane. The maintenance instruction for the various systems of the airplane include system description, troubleshooting, removal and installation of components, and corrective maintenance and testing as required. Each major system of the airplane is covered in a separate section. Only qualified personnel should perform the operations described in this manual.

The description of the airplane included in this section is limited to general information. For more detailed description of the various systems refer to the appropriate section of this manual. For detailed operating instructions refer to the Pilot's Information Manual for the airplane.

Section II of this manual also gives leading particulars and principal dimensions, along with lubrication charts and other related routine service information.

1-3. DESCRIPTION. The Cherokee PA-28R-201T, 28R-201 is a single-engine, low-wing monoplane of a metal construction, with seats available for four passengers and baggage. Paragraphs 1-4 through 1-16 provide descriptions of major components and systems.

1-4. WING. The laminar flow wing is of all-metal stressed-skin, full cantilever, tapered, low-wing design. Each tapered wing panel is bolted to the spar box assembly in the fuselage. The wing tips are made of tough resilient thermoplastic and are easily removed. The ailerons are statically balanced and cable and push rod controlled. The trailing edge wing flaps are manually operated.

1-5. EMPENNAGE. The empennage consists of the fin, rudder, stabilator and stabilator trim tabs. The rudder and stabilator are statically balanced.

1-6. FUSELAGE. The fuselage consists of three basic units: The engine section, the cabin section, and the tail cone section.

1-7. LANDING GEAR. The tricycle landing gear is hydraulically operated, fully retractable unit consisting of shock absorbing air-oil oleo struts.

CHEROKEE ARROW III SERVICE MANUAL

1-8. **HYDRAULIC SYSTEM.** The hydraulic system incorporates an electrically driven pump which is controlled by a selector lever on the instrument panel which in turn operates the retraction and extension of the landing gear.

1-9. **BRAKE SYSTEM.** The brake system is operated hydraulically and controlled by a hand lever connected to a single brake cylinder that operates both wheel brakes, plus individually operated toe brakes.

1-10. **ENGINE** Engine models, rated horsepower and other related information may be found in Table II-I of Section II.

1-11. **PROPELLER.** A constant speed propeller is installed and controlled by an engine mounted governor which is controlled by a lever on the power quadrant in the cockpit. Propeller specifications may be found in Table II-I of Section II and Table VIII-I or VIII A-I of Section VIII and VIIIA.

1-12. **FUEL SYSTEM.** The fuel system consists of an aluminum tank in the leading edge of the wings, a stainer bowl with fuel screen, and electrical auxiliary fuel pump and an engine driven fuel pump.

1-13. **FLIGHT CONTROLS.** The flight controls are conventional equipment, consisting of a control wheel which operates the ailerons and stabilator, and pedals which operate the rudder. Duplicate controls are provided for the copilot.

1-14. **CABIN HEATER, DEFROSTER, AND FRESH AIR SYSTEM.** Heated air for the cabin and defroster is obtained directly from the exhaust system muffler shroud. Fresh air is picked up from an inlet in the leading edge of each wing and from an inlet in the upper leading edge of fin. The air is routed through the wings to individually controlled outlets located just forward of each seat. The fresh air from the fin is routed to overhead vents.

1-15. **RADIO.** Provisions are provided for the installations of various radio equipment along with microphone and other radio navigation equipment.

1-16. **INSTRUMENT AND AUTOPILOT SYSTEM.** Provisions for instrument installation include panels for engine instruments and advanced instruments, as well as for an Autopilot system.

* SECTION II

HANDLING AND SERVICING

Paragraph		Aerofiche Grid No.
2-1.	Introduction	1A18
2-2.	Dimensions.....	1A18
2-3.	Station Reference Lines.....	1A18
2-4.	Weight and Balance Data	1A18
2-5.	Serial Number Plate.....	1A18
2-6.	Access and Inspection Provisions	1A18
2-7.	Tools and Test Equipment	1A18
2-8.	Torque Requirements.....	1B6
2-9.	Walkway, Handhold and Step.....	1B7
2-10.	Ground Handling.....	1B7
2-11.	Introduction to Ground Handling.....	1B7
2-12.	Jacking	1B7
2-13.	Weighing.....	1B9
2-14.	Leveling	1B9
2-15.	Mooring.....	1B10
2-16.	Locking Airplane	1B10
2-17.	Parking	1B10
2-18.	Towing.....	1B10
2-19.	Taxiing.....	1B11
2-20.	External Power Receptacle.....	1B11
2-21.	Operation of External Power Receptacle.....	1B11
2-22.	Cleaning.....	1B12
2-23.	Cleaning Engine Compartment.....	1B12
2-24.	Cleaning Landing Gear.....	1B12
2-25.	Cleaning Exterior Surfaces	1B12
2-26.	Cleaning Windshield and Windows.....	1B12
2-27.	Cleaning Headliner, Side Panels and Seats.....	1B13
2-28.	Cleaning Carpets.....	1B13
2-29.	Servicing.....	1B13
2-30.	Introduction to Servicing	1B13
2-31.	Hydraulic System	1B13
2-32.	Servicing Hydraulic System.....	1B13
2-33.	Servicing Hydraulic Pump/Reservoir.....	1B16

*

Paragraph	Aerofiche Grid No.
2-34. Landing Gear System	1B16
2-35. Servicing Landing Gear.....	1B16
2-36. Oleo Struts.....	1B16
2-37. Servicing Oleo Struts.....	1B16
2-38. Filling Oleo Struts.....	1B17
2-39. Inflating Oleo Struts.....	1B18
2-40. Brake System.....	1B18
2-41. Servicing Brake System.....	1B18
2-42. Filling Brake Cylinder Reservoir.....	1B18
2-43. Draining Brake System.....	1B18
2-44. Tires.....	1B18
2-45. Servicing Tires	1B18
2-46. Power Plant.....	1B18
2-47. Servicing Power Plant.....	1B18
2-48. Induction Air Filter.....	1B19
2-49. Removal of Air Filter.....	1B19
2-50. Service Instruction (Cleaning and Inspection).....	1B19
2-51. Installation of Air Filter	1B19
2-52. Propeller	1B19
2-53. Servicing Propeller.....	1B19
2-54. Fuel System.....	1B19
2-55. Servicing Fuel System	1B19
2-56. Filling Fuel Tanks	1B20
2-57. Draining Moisture from Fuel System	1B20
2-58. Draining Fuel System.....	1B20
2-59. Fuel Additives.....	1B21
2-60. Electrical System.....	1B21
2-61. Servicing Electrical System	1B21
2-62. Lubrication	1B21
2-63. Oil System. (Engine)	1B21
2-64. Servicing Oil System	1B21
2-65. Filling Oil Sump.....	1B21
2-66. Draining Oil Sump.....	1B22
2-67. Oil Filter. (Full Flow).....	1B22
2-68. Recommendations for Changing Oil.....	1B23
2-69. Lubrication Instructions.....	1B23
2-70. Application of Oil	1B24
2-71. Application of Grease	1B24
2-72. Winterization Plate.....	1B24
2-73. Lubrication Charts.....	1C1

SECTION II

HANDLING AND SERVICING

2-1. INTRODUCTION. This section contains routine handling and servicing procedures that are most frequently encountered. Frequent reference to this section will aid the individual by providing information such as the location of various components, ground handling procedures, routine service procedures and lubrication. When any system or component requires service other than the routine procedures as outlined in this section, refer to the appropriate section for that component.

2-2. DIMENSIONS. The principal airplane dimensions are shown in Figures 2-1 and 2-2 and are listed in Table II-I.

2-3. STATION REFERENCE LINES. In order to facilitate the location of various components of the airplane which require maintenance and servicing, a method utilizing fuselage station (Sta.) wing station or buttock line (BL), and water line (WL) designations is frequently employed in this manual. (Refer to Figures 2-3 and 2-4.) Fuselage stations, buttock and water lines are reference points measured by inches in the vertical or horizontal direction from a given reference line which indicates station locations of structural members of the airplane. Station O of the fuselage is 44.5 inches ahead of the lower edge of the firewall; station O (BL) of the wing and stabilator is the centerline of the airplane; and station O (WL) of the fuselage vertical stabilizer and rudder is 20.5 inches below the cabin floor as measured at the rear wing spar with the airplane level.

2-4. WEIGHT AND BALANCE DATA. When figuring various weight and balance computations, the empty, static and gross weight, and center of gravity of the airplane may be found in the Weight and Balance Form of the Airplane Flight Manual.

2-5. SERIAL NUMBER PLATE. The serial number plate is located on the left side of the fuselage near the landing edge of the stabilator. The serial number should always be used when referring to the airplane on service or warranty matters.

2-6. ACCESS AND INSPECTION PROVISIONS. The access and inspection provisions for the airplane are shown in Figure 2-5. The component to be serviced or inspected through each opening is identified in the illustration. All access plates and panels are secured by either metal fasteners or screws. To enter the aft section of the fuselage, open the baggage compartment door and remove the access panel.

CAUTION

Before entering the aft section of the fuselage, be sure the airplane is supported at the tail skid.

2-7. TOOLS AND TEST EQUIPMENT. Because of the simplicity and easy accessibility of components, few special tools outside normal shop tools will be required. Tools that are required may be fabricated from dimensions given in the back of the section that pertains to a particular component or are listed in the back of the PA-28R-201 and PA-28R-201T Parts Catalog.

***CHEROKEE ARROW III SERVICE MANUAL**

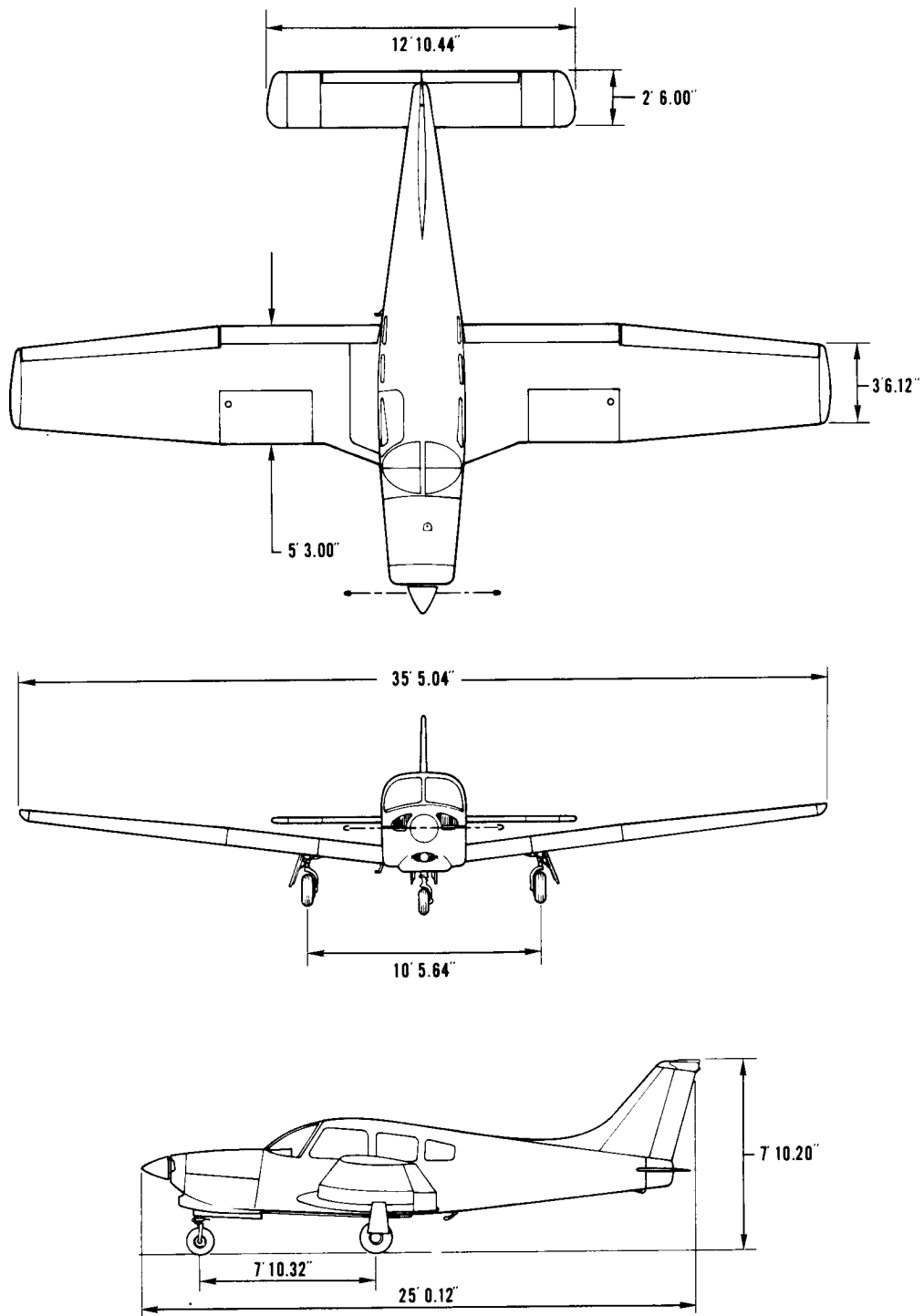

Figure 2-1. Three View of PA-28R-201T

***CHEROKEE ARROW III SERVICE MANUAL**

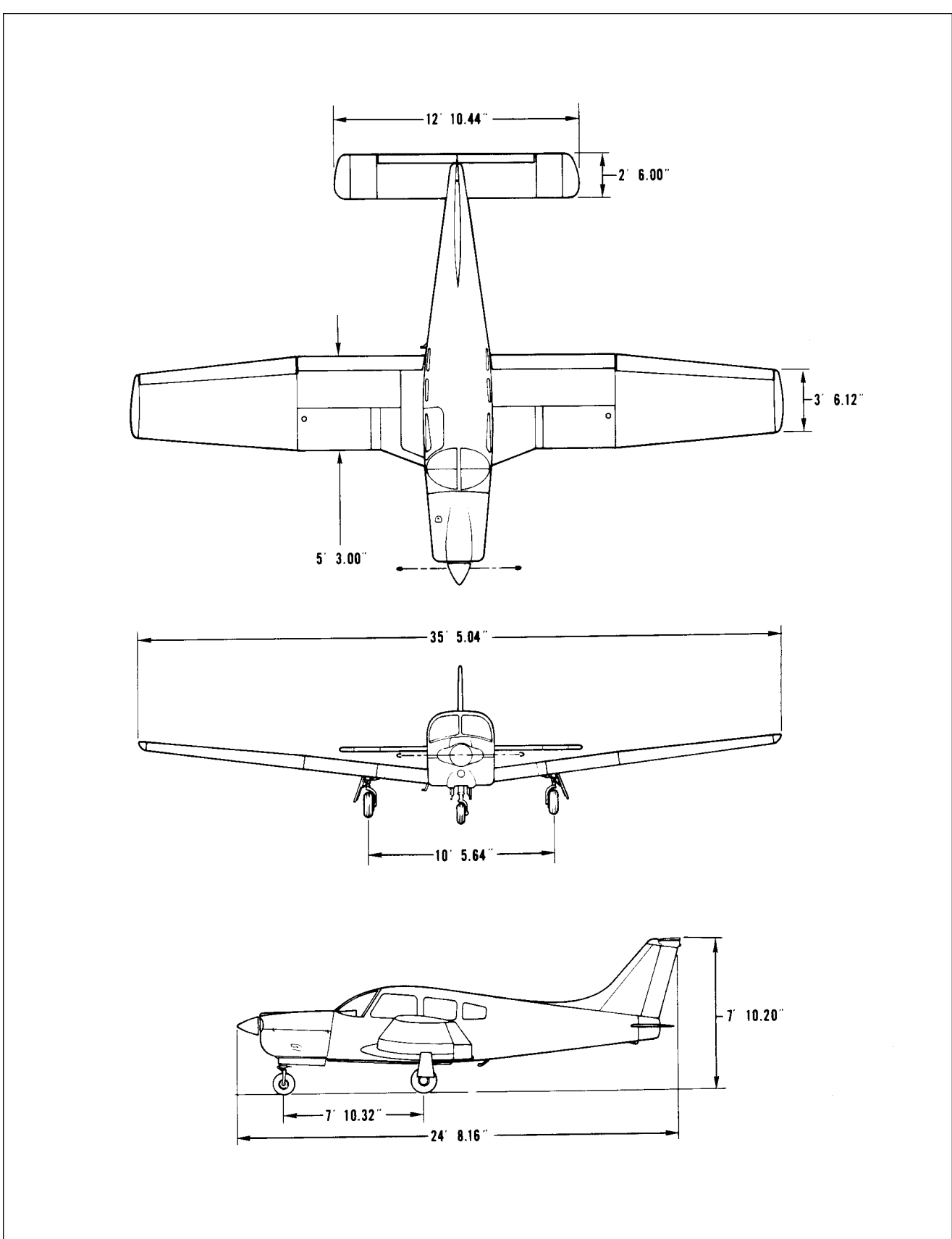

Figure 2-2. Three View of PA-28R-201

***CHEROKEE ARROW III SERVICE MANUAL**

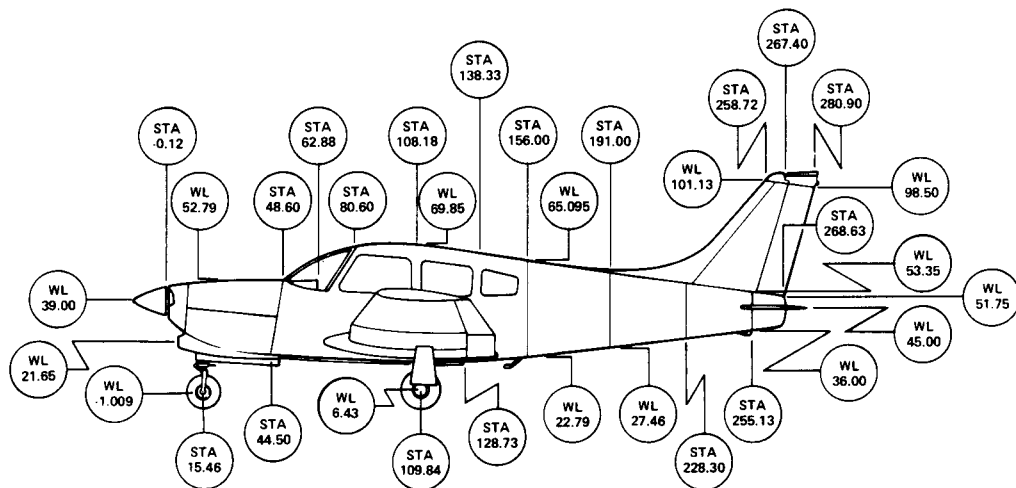
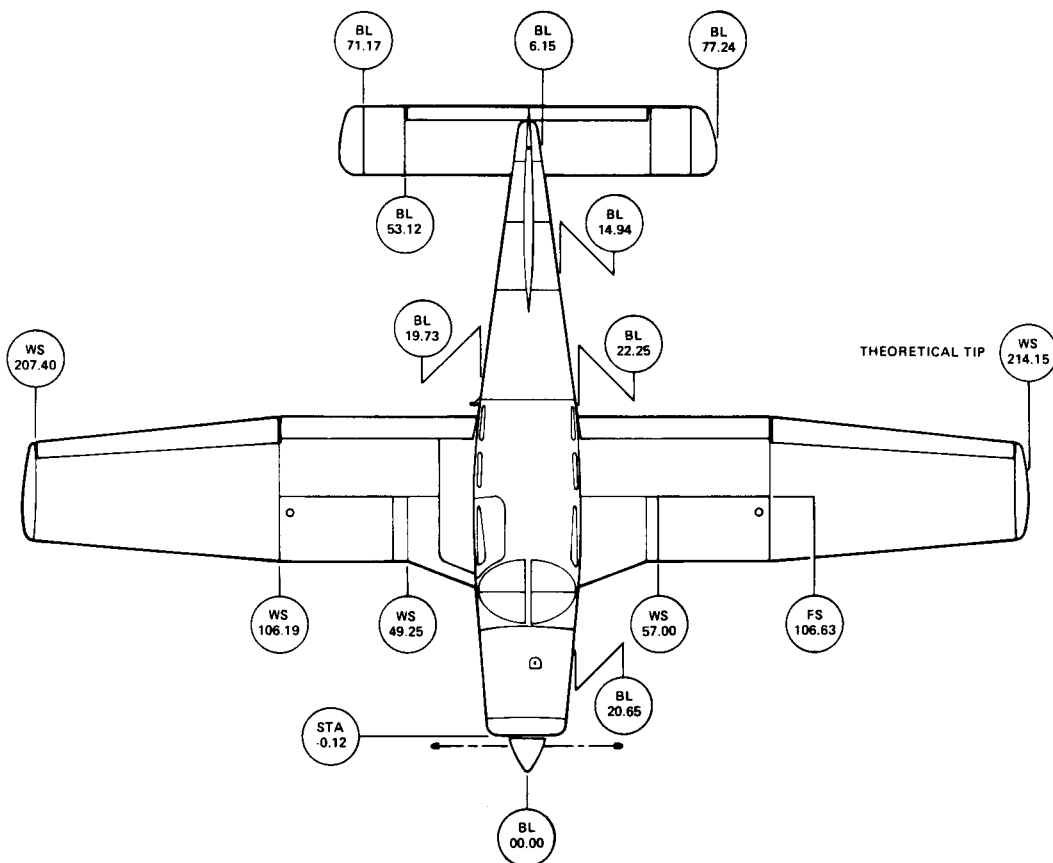

Figure 2-3. Station Reference Lines of PA-28R-201T

***CHEROKEE ARROW III SERVICE MANUAL**

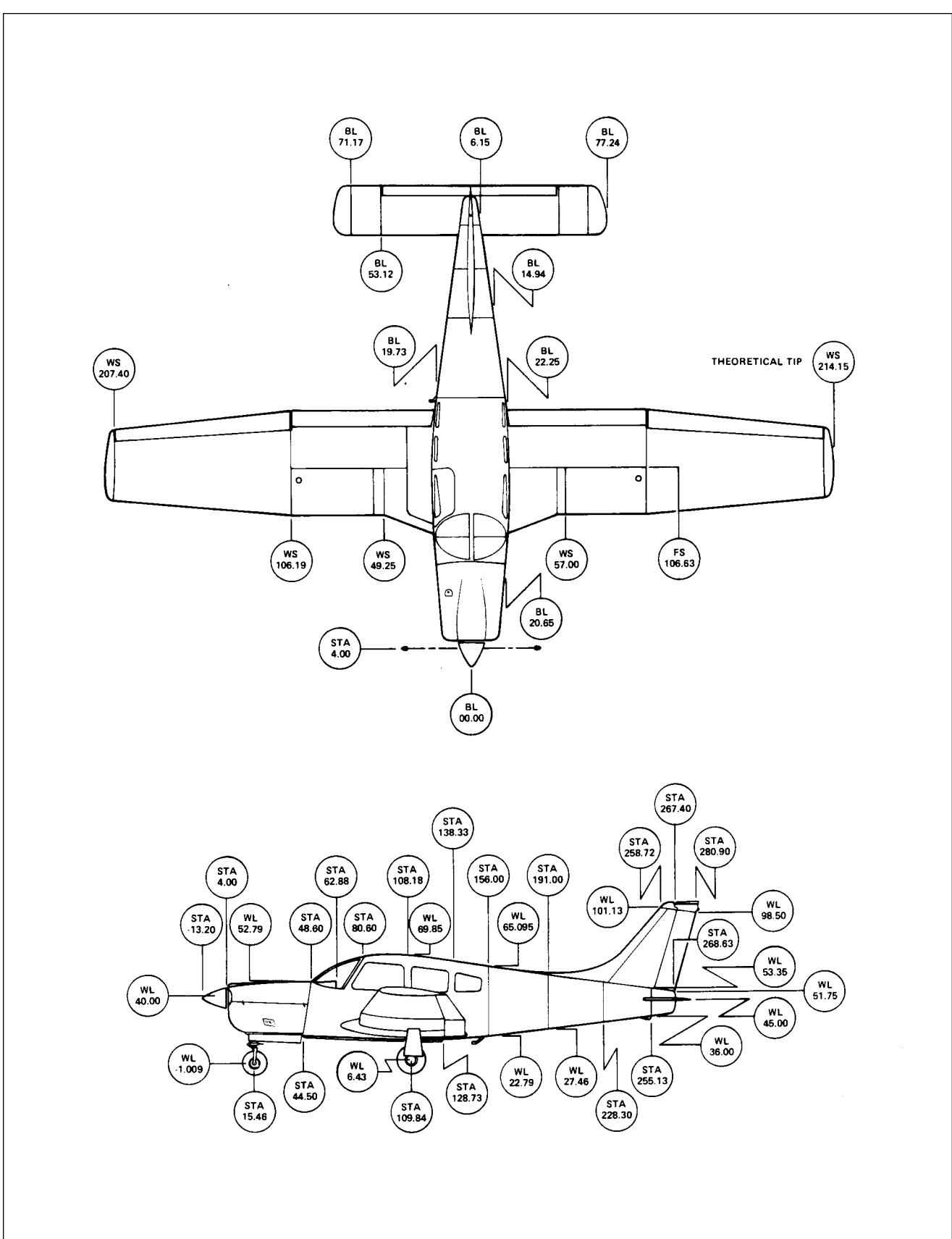

Figure 2-4. Station Reference Lines of PA-28R-201

***CHEROKEE ARROW III SERVICE MANUAL**

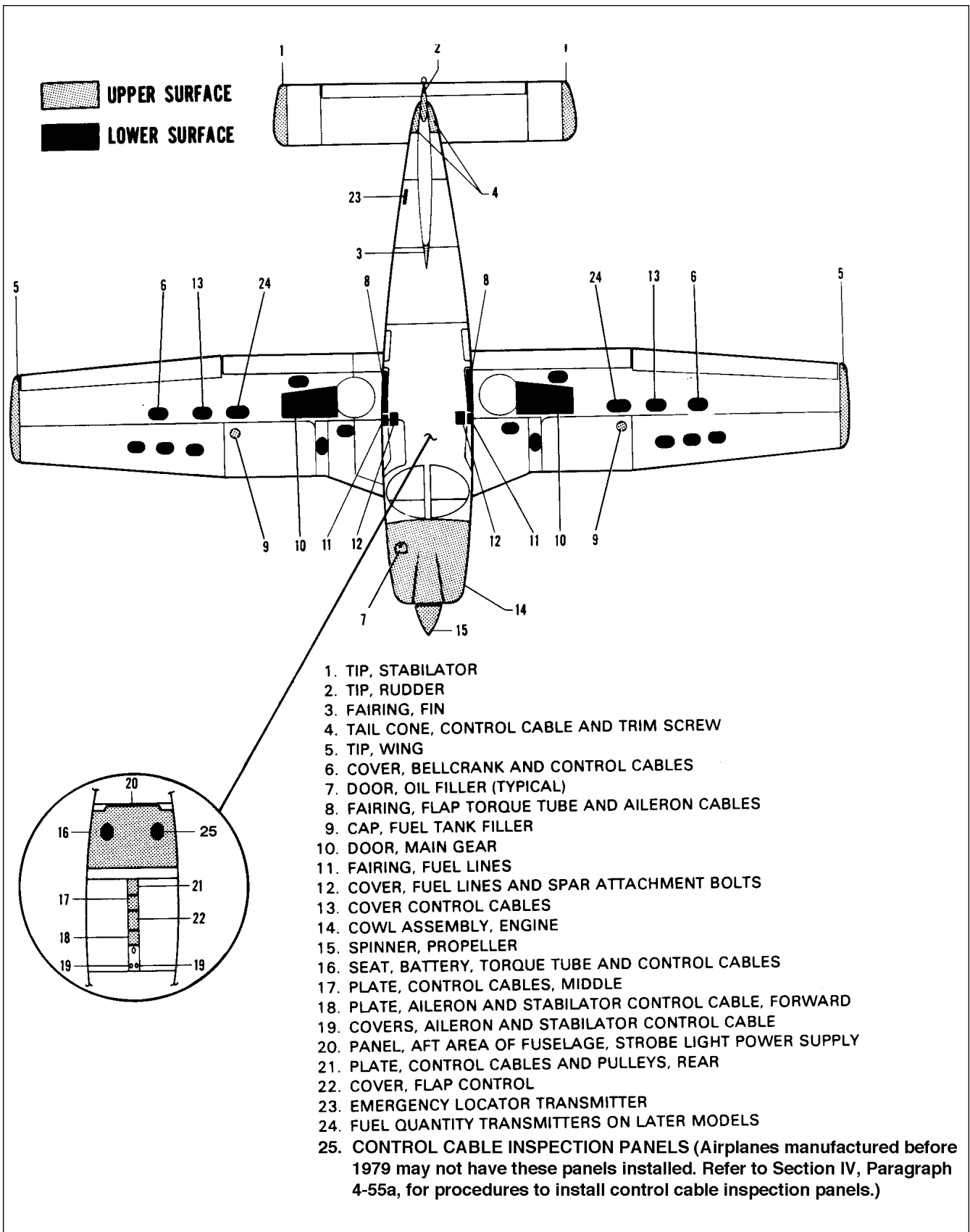

Figure 2-5. Access Plates and Panels

***CHEROKEE ARROW III SERVICE MANUAL**

TABLE II-I. LEADING PARTICULARS AND PRINCIPAL DIMENSIONS

MODEL	PA-28R-201	PA-28R-201T
ENGINE		
Manufacturer	Lycoming	Continental
Model	IO-360-C1C6	TSIO-360-F
FAA Type Certificate		
Rated Horsepower	200	200
Rated Speed:		
Full Throttle	2700 RPM	2575 RPM @ 41.0 in. Hg Manifold Pressure
Propeller Drive Ratio	1:1	1:1
Propeller Shaft Rotation	Clockwise	Clockwise
Bore	5.125 in.	4.438 in.
Stroke	4.375 in.	3.875 in.
Displacement	361 cu. in.	360 cu. in.
Compression Ratio	8.7:1	7.5:1
Weight (with starter and alt.)	328 lbs.	393 lbs.
Dimensions:		
Height	19.48 in.	
Width	34.25 in.	31.38 in.
Length	33.65 in.	57.08 in.
Oil, SAE Number	See Table II-III	See Table II-III
Oil Sump Capacity	8 U.S. quarts	8 U.S. quarts
Oil Consumption, Maximum	.010 lb/bhp/hr	.009 above 75% power
Fuel, Aviation Grade, Minimum and Specified Octane	100/130 or 100LL	100/ 130 or 100LL
Fuel Injector	Bendix	Continental
Magnetos, Bendix:		
Left	S4LN-1227	10-79020-18L
Right	S4LN-1209	10-79020-19L
Magneto Drive, Ratio to Crankshaft	1:1	1.5:1
Magneto Drive, Rotation	Clockwise	Clockwise
Magneto Timing	25° BTC	20° BTC
Magneto Point Clearance	.016	.018
Spark Plugs (Shielded):	Refer to latest Lycoming Service Instruction 1042	Refer to latest Continental Service Bulletin M77-10
Spark Plug Gap Setting	0.015 to 0.021	.015 to .019
Firing Order	1-3-2-4	1-6-3-2-5-4

***CHEROKEE ARROW III SERVICE MANUAL**

TABLE II-I. LEADING PARTICULARS AND PRINCIPAL DIMENSIONS (cont.)

MODEL	PA-28R-201	PA-28R-201T
ENGINE (cont.)		
Starter - Prestolite (12-volt)	MZ4206	MCL-6501
Alternator:		
Chrysler (60 AMP)	2642997	
Prestolite (60 AMP)	ALY-6422	
Prestolite (65 AMP)		ALX-9425A
Alternator Voltage Regulator, WICO	X16300B	X16300B
Alternator Overvoltage Relay, WICO	X16799B	X16799B
PROPELLER - Constant Speed		
Manufacturer	McCauley or Hartzell	Hartzell
Hub, Model	B2D34C213 HC-C2YK-1() F	BHC C2YF-1-BF
Blade, Model	90DHA-16 F7666A-2R	F8459A-8R
Diameter (in.)	74.0 74.0	76.0
Diameter, Minimum (in.)	73.0 72.5	75.0
Blade Angle, Low Pitch*	12.5° ± 0.2° 14.0° ± 0.2°	14.4° ± 0.2°
Blade Angle, High Pitch*	29.8° ± 0.5° 29° ± 2°	29° ± 1.0°
Governor Control and Model	Hartzell F-2-7 (AZ)	Hartzell E-5 or Woodward G210681
*Measured at 30 inch station.		
LANDING GEAR		
Type	Hydraulically Retractable	Hydraulically Retractable
Shock Strut Type	Combination Air-Oil	Combination Air-Oil
Fluid Required (Struts, Hydraulic System and Brakes)	MIL-H-5606A	MIL-H-5606 A
Strut Exposure (Exposure under Static Load):		
Nose	2.75 ± .25 in.	2.75 ± .25 in.
Main	2.00 ± .25 in.	2.00 ± .25 in.
Wheel Tread	10 ft. 5.72 in.	10 ft. 5.72 in.
Wheel Base	7 ft. 10.38 in.	7 ft.10.38 in.
Nose Wheel Travel	30° ± 2° left and right	30° ± 2° left and right

***CHEROKEE ARROW III SERVICE MANUAL**

TABLE II-I. LEADING PARTICULARS AND PRINCIPAL DIMENSIONS (cont.)

MODEL	PA-28R-201	PA-28R-201T
LANDING GEAR (cont.) Turning Radius (Min): Nose Wheel Wing Tip Wheel Nose Wheel Main Brake Type Tires, Nose Tires, Main Tire Pressure, Nose Tire Pressure, Main	15 ft. 8.4 in. 29 ft. 9.6 in. Cleveland 40-77B or McCauley D-30500, 5:00 x 5 Cleveland 40-84, 6:00 x 6 Cleveland 30-55 5 :00 x 5, 4 ply rating 6:00 x 6, 6 ply rating 27 PSI 30 PSI	15 ft. 8.4 in. 29 ft. 9.6 in. Cleveland 40-77B or McCauley D-30S00, 5:00 x 5 Cleveland 40-84, 6:00 x 6 Cleveland 30-55 5 :00 x 5, 4 ply rating 6:00 x 6, 6 ply rating 27 PSI 30 PSI
FUEL SYSTEM Fuel Tanks: Capacity (each) Unusable Fuel (each) Total Capacity Total Unusable Fuel (Refer to Owner's Handbook, Pilot's Information Manual or Flight Manual for Particular Airplane)	38.5 gal. 2.5 gal. 77 gal. 5 gal.	38.5 gal. 2.5 gal. 77 gal. 5 gal.
OVERALL Gross Weight (lbs.) Wing Loading (lbs/sq. ft.) Length Ft. Width (Span) (Wing Tip to Wing Tip) Height (Static Ground Line) Height, Propeller Hub, Thrust Line Level Clearance, Propeller Tips, Normal Static Load Clearance, Propeller Tips, Nose Strut and Tire Flat	2750 16.2 24 ft. 8.25 in. 35 ft. 5.11 in. 7 ft. 1 0.22 in. 47.64 in. 10.40 in. 5.47 in.	2900 17.0 25 ft. 0.23 in. 35 ft. 5.11 in. 7 ft. 1 0.22 in. 46.64 in. 8.20 in. 3.15 in.

TABLE II-II. RECOMMENDED NUT TORQUES

TORQUES: The importance of correct application cannot be overemphasized. Undertorque can result in unnecessary wear of nuts and bolts as well as the parts they are holding together. When insufficient pressures are applied, uneven loads will be transmitted throughout the assembly which may result in excessive wear or premature failure due to fatigue. Overtorque can be equally damaging because of failure of a bolt or nut from overstressing the thread areas. The following procedures should be followed to assure that the correct torque is applied:

1. Torque (self-locking fasteners) — Add the friction torque from Chart A for sizes 8 through 7/16 to the recommended torque from Chart B to get the final torque. This would be the actual reading on the torque wrench.
2. Torque (castellated and non-self-locking nuts) — Use only the torque given in Chart B. Unless otherwise specified, when castellated nuts are used with a cotter pin on moving joints, do not torque the nut. Turn the nut onto the bolt until proper grip is established and alignment with the cotter pin hole is achieved. Then install the cotter pin.

GENERAL REQUIREMENTS:

1. Calibrate the torque wrench periodically to assure accuracy; recheck frequently.
2. Ascertain that the bolt and nut threads are clean and dry (unless otherwise specified by the manufacturer). If the bolt or nut is specified to be lubricated prior to tightening, the torque range should be reduced 50 percent.
3. Use a bolt length long enough to prevent bearing loads on the threads. The complete chamfer or end radius of the bolt or screw must extend through the nut.
4. Unique torques specified in the text of this manual supersede the torques given in Charts A and B.
5. Refer to the latest revision of Lycoming SSP 1776 for torques on parts used on Lycoming engines.
6. A maximum of two AN960 washers may be added under the bolt heads or nuts to correct for variations in material thickness within the tolerances permitted.
7. Limitations of the use of self-locking nuts, bolts and screws including fasteners with non-metallic inserts are as follows:
 - A. Fasteners incorporating self-locking devices shall not be reused if they can be run up using only fingers. They may be reused if hand tools are required to run them up, providing there is no obvious damage to the self-locking device prior to installation.
 - B. Bolts 5/16 inch diameter and over with cotter pin holes may be used with self-locking nuts. Nuts with non-metallic locking devices may be used in this application only if the bolts are free from burrs around the cotter pin hole.
 - C. Do not use self-locking nuts at joints which subject either the nut or the bolt to rotation.
 - D. Never tap or rethread self-locking fasteners. Do not use nuts, bolts or screws with damaged threads or rough ends.

CHEROKEE ARROW III SERVICE MANUAL

TABLE II-II. RECOMMENDED NUT TORQUES (cont.)

BOLT SIZE		FRICTION DRAG TORQUE (IN. -LB.)		COARSE THREAD SERIES					
8 (course thread)	15	BOLTS Steel Tension AN 3 THRU AN 20 AN 42 THRU AN 49 AN 73 THRU AN 81 AN 173 THRU AN 186 MS 20033 THRU MS 20046 MS 20073 MS 20074 AN 509 NK9 MS 24694 AN 525 NK525 MS 27039				NUTS			
10	18					Steel Tension		Steel Shear	
1/4	30					AN 310		AN 320	
5/16	60					AN 315		AN 364	
3/8	80					AN 363		NAS 1022	
7/16	100					AN 365		MS 17826	
		NAS 1021		MS 20364					
		MS 17825							
		MS 21045							
		MS 20365							
		MS 20500							
		NAS 679							
		Torque Limits in-lbs.		Torque Limits in-lbs.					
		Min.		Max.		Min.			
		Max.		Min.		Max.			
		8-32		12		15			
		10-24		20		25			
		1/4-20		40		50			
		5/16-18		80		90			
		3/8-16		160		185			
		7/16-14		235		255			
		1/2-13		400		480			
		9/16-12		500		700			
		5/8-11		700		900			
		3/4-10		1,150		1,600			
		7/8-9		2,200		3,000			
		1-8		3,700		5,000			
		1-1/8-8		5,500		6,500			
		1-1/4-8		6,500		8,000			

CHEROKEE ARROW III SERVICE MANUAL

TABLE II-II. RECOMMENDED NUT TORQUES (cont.)

FINE THREAD SERIES												
	BOLTS Steel Tension				BOLTS Steel Tension				BOLTS Aluminum			
	AN 3 THRU AN 20 AN 42 THRU AN 49 AN 73 THRU AN 81 AN 173 THRU AN 186 MS 20033 THRU MS 20046 MS 20073 MS 20074 AN 509 NK9 MS 24694 AN 525 NK525 MS 27039				MS 20004 THRU MS 20024 NAS 144 THRU NAS 158 NAS 333 THRU NAS 340 NAS 583 THRU NAS 590 NAS 624 THRU NAS 644 NAS 1303 THRU NAS 1320 NAS 172 NAS 174 NAS 517				AN 3DD THRU AN 20DD AN 173DD THRU AN 186DD AN 509DD AN 525D MS 27039D MS 24694DD			
	NUTS Steel Tension		NUTS Steel Shear		NUTS Steel Tension		NUTS Steel Shear		NUTS Alum. Tension		NUTS Alum. Shear	
AN 310 AN 315 AN 363 AN 365 NAS 1021 MS 17825 MS 21045 MS 20365 MS 20500 NAS 679		AN 320 AN 364 NAS 1022 MS 17826 MS 20364		AN 310 AN 315 AN 363 AN 365 MS 17825 MS 20365 MS 21045 NAS 1021 NAS 679 NAS 1291		AN 320 AN 364 NAS 1022 MS 17826 MS 20364		AN 365D AN 310D NAS 1021D		AN 320D AN 364D NAS 1022D		
Nut-bolt size	Torque Limits in-lbs.		Torque Limits in-lbs.		Torque Limits in-lbs.		Torque Limits in-lbs.		Torque Limits in-lbs.		Torque Limits in-lbs.	
	Min.	Max.	Min.	Max.	Min.	Max.	Min.	Max.	Min.	Max.	Min.	Max.
8-36	12	15	7	9					5	10	3	6
10-32	20	25	12	15	25	30	15	20	10	15	5	10
1/4-28	50	70	30	40	80	100	50	60	30	45	15	30
5/16-24	100	140	60	85	120	145	70	90	40	65	25	40
3/8-24	160	190	95	110	200	250	120	150	75	110	45	70
7/16-20	450	500	270	300	520	630	300	400	180	280	110	170
1/2-20	480	690	290	410	770	950	450	550	280	410	160	260
9/16-18	800	1,000	480	600	1,100	1,300	650	800	380	580	230	360
5/8-18	1,100	1,300	660	780	1,250	1,550	750	950	550	670	270	420
3/4-16	2,300	2,500	1,300	1,500	2,650	3,200	1,600	1,900	950	1,250	560	880
7/8-14	2,500	3,000	1,500	1,800	3,550	4,350	2,100	2,690	1,250	1,900	750	1,200
1-14	3,700	4,500	2,200	3,300	4,500	5,500	2,700	3,300	1,600	2,400	950	1,500
1-1/8-12	5,000	7,000	3,000	4,200	6,000	7,300	3,600	4,400	2,100	3,200	1,250	2,000
1-1/4-12	9,000	11,000	5,400	6,600	11,000	13,400	6,600	8,000	3,900	5,600	2,300	3,650

*CHEROKEE ARROW III SERVICE MANUAL

2-8. TORQUE REQUIREMENTS. The torque values given in Table II-II are derived from oil-free cadmium-plated threads and are recommended for all airframe installations procedures where torquing is required, unless otherwise noted in sections where other values are stipulated. Engine torque values for PA-28R-201 are found in the latest revision of Avco-Lycoming Service Bulletin No. 268. Engine torque values for PA-28R-201T are found in the latest revision of Teledyne Continental Overhaul Manual. Propeller torque values are found in Section VII or VIIA of this manual.

- a. Unless otherwise specified, torque all nuts to the applicable torque as given in Table II-II. If the nut (or bolt) is listed but not its mating fastener, use the lower torque specified for the listed nut (or bolt).

NOTE

If normal operation requires movement between any of the components being clamped together, tighten the nut (or bolt) without regard to the nut torque chart to ensure intended operation of the assembly.

- b. If the bolt and nut threads are to be lubricated and no torque has been specified, reduce the recommended nut torque (plus friction drag torque) by 50%.
- c. For thread sizes 10 through 7/16, add the friction drag torque for all self-locking fasteners as specified in the friction drag torque table. For non self-locking fasteners, assume the friction drag torque to be zero.
- d. For bolt sizes other than those mentioned above, determine the friction drag torque by turning the nut to near contact with the bearing surface. Attach a scale type torque wrench to the nut and determine the torque required to turn the nut on the bolt before the nut contacts the bearing surface. Add the friction drag torque to the recommended torque to get the final torque.

NOTE

If the bolt is stationary and the nut is torqued, use the lower side of the torque range. If the nut is stationary and the bolt is torqued, use the higher side of the torque range.

- e. When torquing castellated nuts, begin with minimum torque plus friction drag torque. Do not exceed maximum torque plus friction drag torque when trying to align slot on nut with hole in bolt shank. If they do not align, change washers and try again. When using castellated nuts on movable joints, do not torque as described above. Tighten nuts only to remove looseness in the joint and then install the cotter pin.
- f. After the final torque has been applied, the nut (or bolt or screw if no nut is used) should be permanently marked red and should not be further tightened or disturbed.

2-9. WALKWAY, HANDHOLD AND STEP. The walkway is made of a non-skid compound applied to paper and bonded to the wing surface. A fixed handhold is located on the right side of the fuselage near the rear window. A step is available as optional equipment and is installed just aft of the trailing edge of the right flap.

2-10. GROUND HANDLING.

2-11. INTRODUCTION TO GROUND HANDLING. Ground handling covers all essential information governing the handling of the airplane while on the ground. This includes jacking, weighing, leveling mooring, parking, towing and taxiing. When the airplane is handled in the manner described in the following paragraphs, possible damage to the airplane and its equipment will be prevented.

CAUTION

When moving airplane forward by hand avoid pushing on the trailing edge of the ailerons for this will result in an out of trim condition.

2-12. JACKING. Jacking the airplane is necessary to service the landing gear and to perform other service operations. Proceed as follows:

- a. Place jacks under jack pads on the front wing spar. (Refer to Figure 2-6.)

NOTE

A jacking point on the airplane is also provided on the underside of the fuselage directly behind the nose gear actuating cylinder. This may be used along with the wing jack points to raise the airplane, or alone it may be used to raise the front end.

- b. Attach the tail support to the tail skid. Place approximately 250 pounds of ballast on the base of the tail support to hold down the tail.

CAUTION

Be sure to apply sufficient tail support ballast; otherwise the airplane will tip forward.

- c. Raise the jacks until all three wheels are clear of the surface.

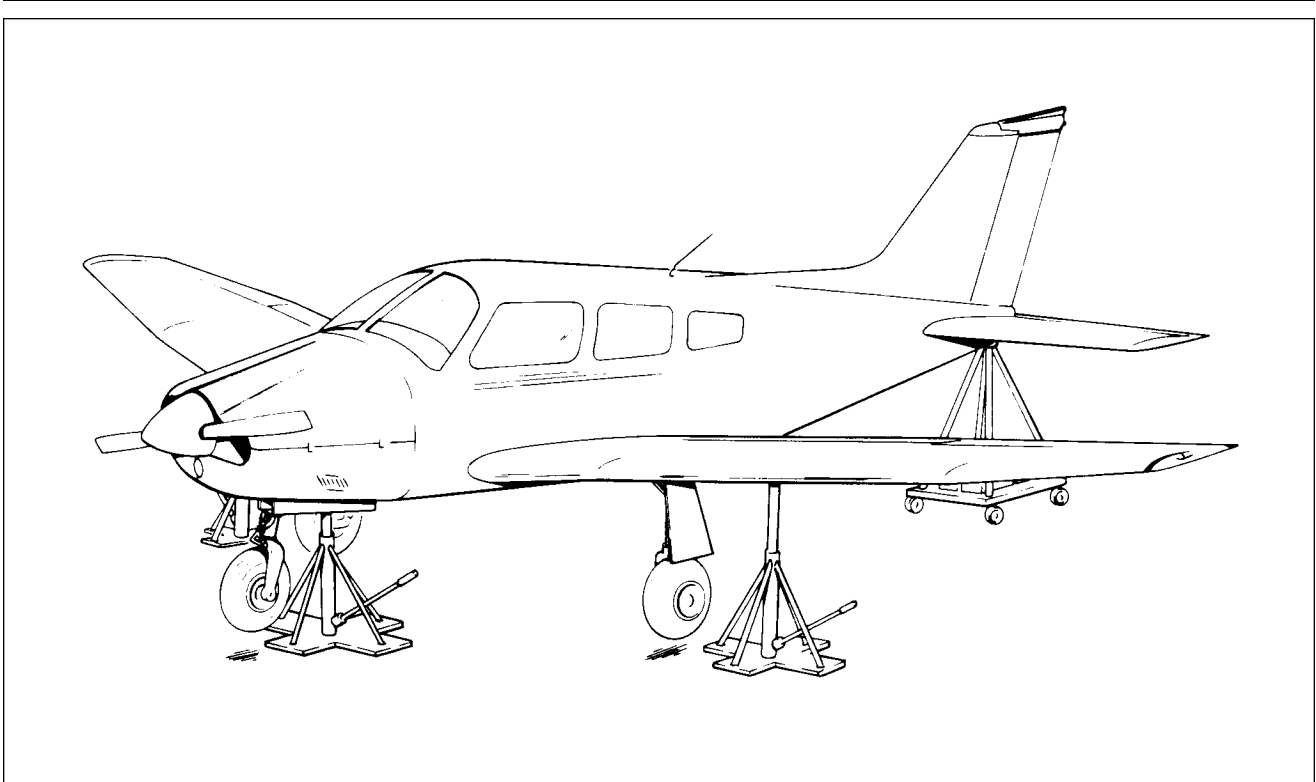

Figure 2-6. Jacking Arrangement

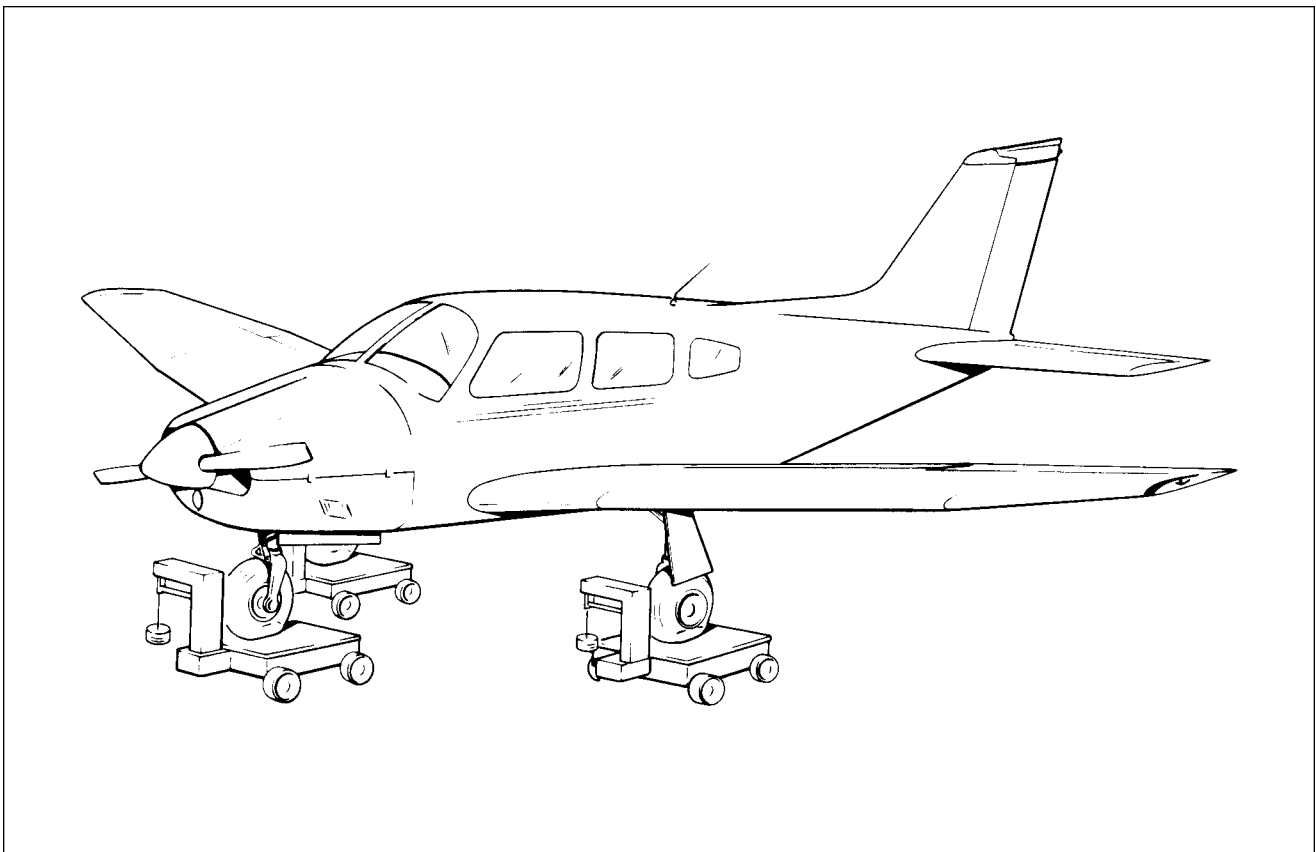

Figure 2-7. Weighing Arrangement

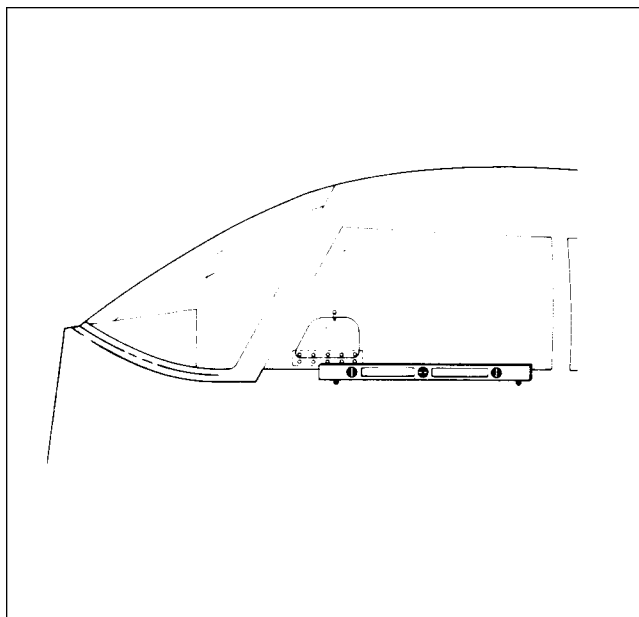

Figure 2-8. Leveling Longitudinally

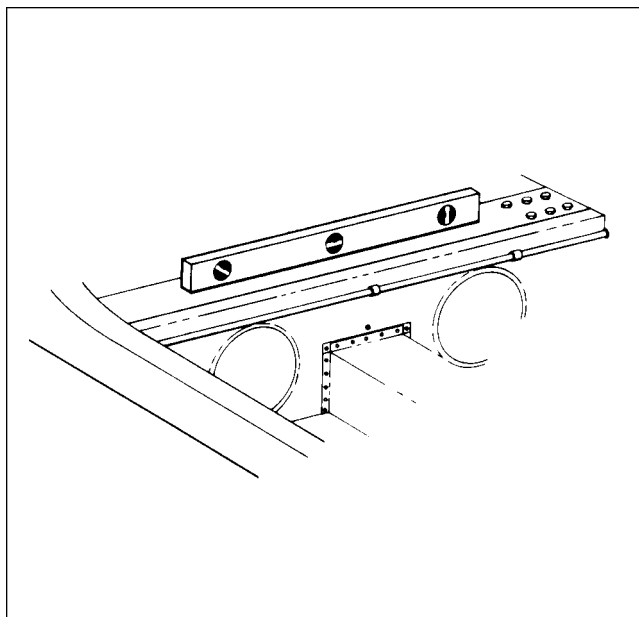

Figure 2-9. Leveling Laterally

2-13. **WEIGHING.** (Refer to Figure 2-7.) The airplane may be weighed by the following procedure:

- a. Position a scale and ramp in front of each of the three wheels.
- b. Secure the scales from rolling forward and tow the airplane up onto the scales. (Refer to Paragraph 2-18.)
- c. Remove the ramp so as not to interfere with the scales.
- d. If the airplane is to be weighed for weight and balance computations, level the airplane per instructions given in Paragraph 2-14.

2-14. **LEVELING.** The airplanes are provided with a means for longitudinal and lateral leveling. The airplanes may be leveled while on jacks, during the weighing procedure while the wheels are on scales, or while the wheels are on the ground. To level the airplane for purposes of weighing or rigging, the following procedures may be used:

- a. To longitudinally level the airplane, partially withdraw the two leveling screws located immediately below the left front side window. (Refer to Figure 2-8.) Place a level on these screws heads and adjust the jacks until the level is centered. Should the airplane be either on scales or on the floor, first block the main gear oleos to full extension; then deflate the nose wheel until the proper position is reached.
- b. To laterally level the airplane, place a level across the spar box assembly located under the rear seat. (Refer to Figure 2-9.) Raise or lower one wing tip by deflating the appropriate tire on the high side of the airplane or adjust either jack until the bubble of the level is centered.

2-15. MOORING. The airplane is moored to insure its immovability, protection and security under various weather conditions. In order to properly moor the airplane use the following procedures:

- a. Head the airplane into the wind, if possible.
- b. Block the wheels.
- c. Lock the aileron and stabilator controls using the front seat belt.
- d. Secure tie-down ropes to the wing tie-down rings and the tail skid at approximately 45 degree angles to the ground. When using rope constructed of non-synthetic material, leave sufficient slack to avoid damage to the airplane when the ropes contract due to moisture.

CAUTION

Use square or bowline knots. Do not use slip knots.

NOTE

Additional preparations for high winds include using tie-down ropes from the landing gear forks, and securing the rudder.

- e. Install pitot tube cover, if available.

2-16. LOCKING AIRPLANE. The cabin and baggage compartment doors are provided with a key lock on the outside. The ignition switch and cabin door require the same key while the baggage compartment door has a separate key.

2-17. PARKING. When parking the airplane, insure that it is sufficiently protected against adverse weather conditions and presents no danger to other aircraft. When parking the airplane for any length of time or overnight, it is recommended that it be moored as in Paragraph 2-15.

- a. To park the airplane, head it into the wind, if possible.
- b. Set the parking brake by pulling back the brake lever and depressing the knob attached to the left side of the handle, then release the handle. To release the parking brake, pull back on the brake lever to disengage the catch mechanism, and allow the handle to swing forward.

NOTE

Care should be taken when setting brakes that are overheated or during cold weather when accumulated moisture may freeze the brakes.

- c. The aileron and stabilator may be locked by using the front seat belt.

2-18. TOWING. The airplane may be moved by using the nose wheel steering bar that is stowed in the baggage area or power equipment that will not damage or cause excess strain to the nose gear steering assembly. The stem on the bar is inserted in the hollow of the nose wheel axle at its right side.

CAUTION

When towing with power equipment, do not turn the nose gear in either direction beyond its steering radius limits as this will result in damage to the nose gear and steering mechanism.

In the event towing lines are necessary, lines (rope) should be attached to both main gear struts as high up on the tubes as possible. Lines should be long enough to clear the nose and/or tail by not less than 15 feet, and a qualified person to ride in the pilot's seat to maintain control by use of the brakes.

2-19. TAXIING. Before attempting to taxi the airplane, ground personnel should be checked out by qualified pilot or other responsible person. Engine starting and shut-down procedures should be covered as well. When it is ascertained that the propeller back blast and taxi areas are clear, apply power to start the taxi roll and perform the following checks:

- a. Taxi forward a few feet and apply brakes to determine their effectiveness.
- b. Taxi with propeller set in low pitch, high RPM setting.
- c. While taxiing, make slight turns to ascertain the effectiveness of steering.
- d. Observe wing clearances when taxiing near buildings or other stationary objects. If possible station a guide outside the airplane to observe.
- e. When taxiing on uneven ground, avoid holes and ruts.
- f. Do not operate the engine at high RPM when running up or taxiing over ground containing loose stones, gravel or any loose material that may cause damage to the propeller blades.

2-20. EXTERNAL POWER RECEPTACLE.

2-21. OPERATION OF EXTERNAL POWER RECEPTACLE. The external power receptacle is located on the right side of the fuselage aft of the wing. When using external power for starting or operation of any of the airplanes equipment the following procedure should be followed:

- a. Turn aircraft MASTER SWITCH to OFF position.
- b. Ensure that the RED lead of PEP (Piper External Power) kit jumper cable is connected to the POSITIVE (+) terminal of the external 12-volt battery and that the BLACK lead is connected to the NEGATIVE terminal.
- c. Insert the plug of jumper cable into the socket located on the aircraft fuselage.
- d. Turn the aircraft MASTER SWITCH ON and proceed with NORMAL engine starting technique
- e. After the engine has been started, turn the MASTER SWITCH to the OFF position and remove the jumper cable plug from the aircraft.
- f. Turn the aircraft MASTER SWITCH to the ON position and check the alternator ammeter for an indication of output. (DO NOT ATTEMPT ANY FLIGHT IF THERE IS NO INDICATION OF ALTERNATOR OUTPUT.)

NOTE

If aircraft battery is weak, charging current will be high. Do not take off until charging current falls below 20 amps. Do not take off with a completely discharged battery as three volts is needed to excite the alternator.

2-22. CLEANING.

2-23. CLEANING ENGINE COMPARTMENT. Before cleaning the engine compartment, place a strip tape on the magneto vents to prevent any solvent from entering these units.

- a. Place a pan under the engine to catch waste.
- b. With the engine cowling removed, spray or brush the engine with solvent or a mixture of solvent and degreaser, as desired. It may be necessary to brush areas that were sprayed where heavy grease and dirt deposits have collected in order to clean them.

CAUTION

Do not spray solvent into the alternator, starter, air intake, and alternate air inlets.

- c. Allow the solvent to remain on the engine from five to ten minutes, then rinse the engine clean with additional solvent and allow to dry.

CAUTION

Do not operate engine until excess solvent has evaporated or otherwise been removed.

- d. Remove the protective covers from the magnetos.
- e. Lubricate controls, bearing surfaces, etc. per Lubrication Chart.

2-24. CLEANING LANDING GEAR. Before cleaning the landing gear, place a plastic cover or similar material over the wheel and brake assembly.

- a. Place a pan under the gear to catch waste.
- b. Spray or brush the gear area with solvent or a mixture of solvent and degreaser, as desired. It may be necessary to brush areas that were sprayed where heavy grease and dirt deposits have collected in order to clean them.
- c. Allow the solvent to remain on the gear from five to ten minutes, then rinse the gear with additional solvent and allow to dry.
- d. Remove the cover from the wheel and remove the catch pan.
- e. Lubricate the gear per Lubrication Chart.

2-25. CLEANING EXTERIOR SURFACES. The airplane should be washed with a mild soap and water. Harsh abrasives or detergents used on painted or plastic surfaces could make scratches or cause corrosion of metal surfaces. Cover areas where cleaning solution could cause damage. Cover the mast of the gear back-up extender. To wash the airplane, the following procedure may be used:

- a. Flush away loose dirt with water.
- b. Apply cleaning solution with a rag, sponge or soft bristle brush.
- c. To remove stubborn oil and grease, use a cloth dampened with naphtha.
- d. Where exhaust stains exist, allow solution to remain on the surface longer.
- e. Any good automotive wax may be used to preserve the painted surfaces. Solt cleaning cloths or chamois should be used to prevent scratches when cleaning or polishing. A heavier coating of wax on the leading surfaces will reduce the abrasion problems in these areas.

2-26. CLEANING WINDSHIELD AND WINDOWS

- a. Remove dirt, mud, etc. from exterior surfaces with clean water.
- b. Wash with mild soap and warm water or an aircraft plastic cleaner using a soft cloth or sponge and a straight rubbing motion. Do not harshly rub surfaces.
- c. Remove oil and grease with a cloth moistened with kerosene.

NOTE

Do not use gasoline, alcohol, benzene, carbon tetrachloride, thinner, acetone or window cleaning sprays.

- d. After cleaning plastic surfaces, apply a thin coat of hard polishing wax. Rub lightly with a soft cloth. Do not use a circular motion.
- e. A severe scratch or mar in plastic can be removed by using jeweler's rouge to rub out the scratch. Smooth both sides and apply wax.
- f. To improve visibility through windshield and windows during flight through rain, a rain repellent such as REPCON should be applied to the windshield and windows. The surfaces of the windshield and windows treated becomes so smooth that water beads up and readily flows off the surface. Apply this product in accordance with the manufacturer's instructions. REPCON is manufactured by Unelko Corp., 727 E. 110 Street, Chicago, Illinois 60628.

2-27. CLEANING HEADLINER, SIDE PANELS AND SEATS.

- a. Clean headliner, side panels and seats with a stiff bristle brush and vacuum where necessary.
- b. Soiled upholstery, except leather, may be cleaned by using an approved air type cleaner or foam upholstery cleaner. Carefully follow the manufacturer's instructions. Avoid soaking or harsh rubbing.

CAUTION

Solvent cleaners required adequate ventilation.

- c. Leather material should be cleaned with saddle soap or mild soap and water.

2-28. CLEANING CARPETS. Use a small whisk broom or vacuum to remove dirt. For soiled spots, use non-inflammable dry-cleaning fluid.

2-29. SERVICING.

2-30. INTRODUCTION OF SERVICING. Servicing the airplane includes the replenishment of fuel, oil, hydraulic fluid, tire pressures, lubrication requirements and other required items.

2-31 . HYDRAULIC SYSTEM

2-32. SERVICING HYDRAULIC SYSTEM. The general condition of the hydraulic pump and landing gear actuating cylinders should be checked. Ensure that there are no leaks and that the line fittings are tight. The cylinder rods are to be free of all dirt and grit. To clean the rods use an oil soaked rag and carefully wipe them. All the hydraulic lines should also be checked for leaks, kinks, and corrosion. Check the tightness of the attachment fittings.

The gear back up extender actuator assembly is located beneath the rear seat and should be checked determine that it is operating properly. The diaphragm shaft may be operated by hand to make sure that is free to fluctuate and that the actuating arm and its components are operating freely. Check the pressure housing assembly for cracks, breaks, or fatigue. Check to ensure that the hydraulic valve and fittings a free of leaks.

Repair and check procedures for the hydraulic pump, cylinders and various components may be found in Section VI of this manual.

***CHEROKEE ARROW III SERVICE MANUAL**

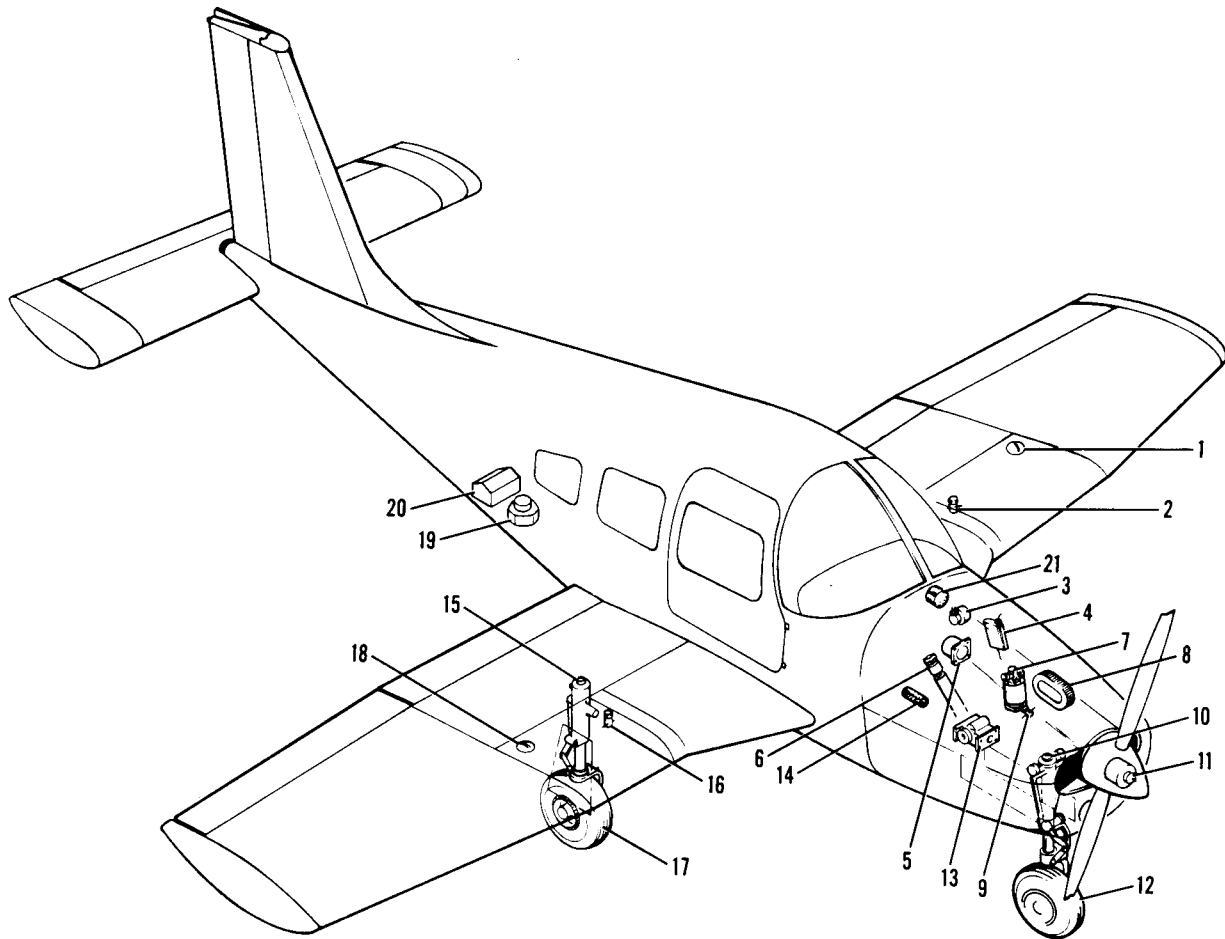

1. FILLER, FUEL TANK, LEFT
2. DRAIN, FUEL TANK, LEFT
3. FILTER, VACUUM REGULATOR AND CENTRAL AIR
4. RESERVOIR, BRAKE SYSTEM
5. ENGINE OIL FILTER
6. FILLER/INDICATOR, OIL, ENGINE
7. SCREEN, FUEL DRAIN
8. FILTER, CARTRIDGE, ENGINE INDUCTION
9. DRAIN, FUEL ENGINE
10. FILLER, OLEO SHOCK STRUT, NOSE
11. PROPELLER (HARTZELL)
12. TIRE, NOSE
13. INJECTOR, FUEL
14. SCREEN, OIL SUCTION, ENGINE
15. FILLER, OLEO SHOCK STRUT, L AND R
16. DRAIN, FUEL TANK, RIGHT
17. TIRE, L AND R
18. FILLER, FUEL TANK, RIGHT
19. PUMP/RESERVOIR, HYDRAULIC SYSTEM
20. BATTERY
21. FILTER, INSTRUMENTS

Figure 2-10. Servicing Points (PA-28R-201)

***CHEROKEE ARROW III SERVICE MANUAL**

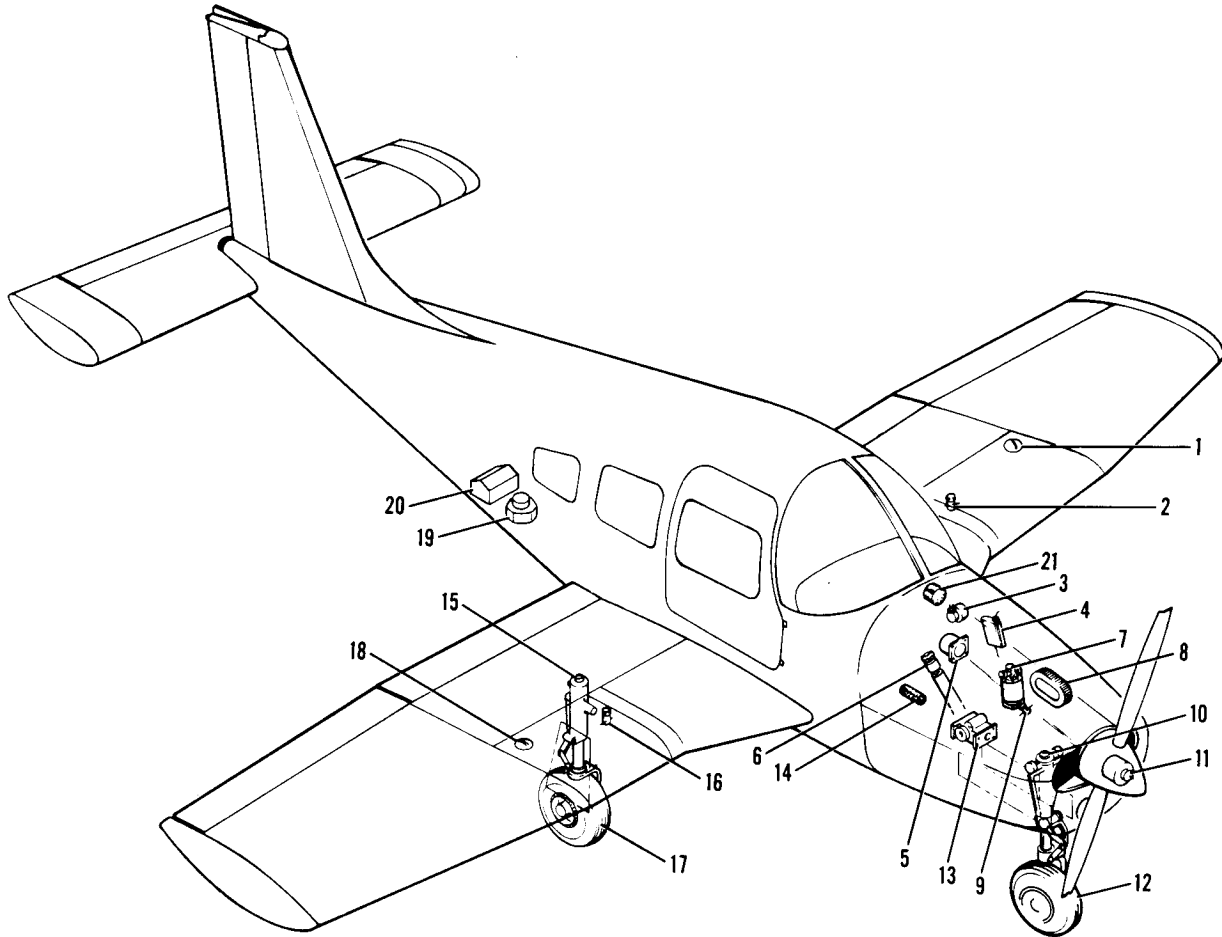

1. FILLER, FUEL TANK, LEFT
2. DRAIN, FUEL TANK, LEFT
3. FILTER, VACUUM REGULATOR AND CENTRAL AIR
4. RESERVOIR, BRAKE SYSTEM
5. ENGINE OIL FILTER
6. FILLER/INDICATOR, OIL, ENGINE
7. SCREEN, FUEL DRAIN
8. FILTER, CARTRIDGE, ENGINE INDUCTION
9. DRAIN, FUEL ENGINE
10. FILLER, OLEO SHOCK STRUT, NOSE
11. PROPELLER (HARTZELL)
12. TIRE, NOSE
13. INJECTOR, FUEL
14. SCREEN, OIL SUCTION, ENGINE
15. FILLER, OLEO SHOCK STRUT, L AND R
16. DRAIN, FUEL TANK, RIGHT
17. TIRE, L AND R
18. FILLER, FUEL TANK, RIGHT
19. PUMP/RESERVOIR, HYDRAULIC SYSTEM
20. BATTERY
21. FILTER, INSTRUMENTS

Figure 2-11. Servicing Points (PA-28R-201T)

2-33. SERVICING HYDRAULIC PUMP/RESERVOIR. The fluid level of the reservoir of the combination pump and reservoir should be checked every 50 hours by viewing the fluid through the filler plug hole in the hydraulic pump. Access to the pump is through the panel at the right rear side of the baggage compartment.

To check fluid level, remove the filler plug located on the forward side of the pump and ascertain that fluid is visible up to the bottom of the filler plug hole. Should fluid be below the hole, add fluid, MIL-H-5606A, through the filler hole until full. Reinstall the filler plug and tighten.

NOTE

A small vent hole is located under the vent screw head. Retain 1/64 inch clearance between the screw head and the small vent hole.

2-34. LANDING GEAR SYSTEM.

2-35. SERVICING LANDING GEAR. The landing gear consists of tires, brakes and oleo strut assemblies. These should be inspected for proper gear extension, scored piston tubes, possible hydraulic fluid leakage and security and condition of all connection points. Check the brake linings for wear and frayed edges, and brake discs for scoring. Replace if found necessary. Checked for proper adjustment of downlock hooks looseness of drag links and side brace links. Minor servicing is described in the following paragraphs, and for detailed service and overhaul instructions refer to Section VII.

2-36. OLEO STRUTS.

2-37. SERVICING OLEO STRUTS. The air-oil type oleo strut should be maintained at proper strut tube exposures for best oleo action. The nose gear strut must have approximately 2.75 inches of piston tube exposed, while the main gear strut requires approximately 2.0 inches of tube exposure. These measurements are taken with the airplane sitting on level surface under normal static load. (Empty weight of airplane plus full fuel and oil.) If the strut has less tube exposure than prescribed, determine whether it needs air or oil by rocking the airplane. If the oleo strut oscillated with short strokes (approximately one inch) and the airplane settles to its normal position within one or two cycles after the rocking force is removed, the oleo strut requires inflating. Check the valve core and filler plug for air leaks, correct if required, and add air as described in Paragraph 2-39. If the oleo strut oscillates with long strokes (approximately three inches) and the airplane continues to oscillate after the rocking force is removed, the oleo struts require fluid. Check the oleo for indications of oil leaks, correct if required and add fluid as described in Paragraph 2-38. For repair procedures of the landing gear and/or oleo struts, refer to Section VII.

WARNING

Do not release air by removing the strut valve core or filler plug. Depress the valve core pin until strut chamber pressure has diminished.

CAUTION

Dirt and foreign particles form around the filler plugs of the landing gear struts, therefore, before attempting to remove these plugs, the tops of the struts should be cleaned with compressed air and/or with a dry solvent.

2-38. FILLING OLEO STRUTS. To fill the nose or main gear oleo strut with fluid (MIL-H-5606A), whether it be the addition of a small or large amount, procede as follows:

- a. Raise the airplane on jacks. (Refer to Paragraph 2-12.)
- b. Place a pan under the gear to catch spillage.
- c. At the filler plug, relieve air pressure from the strut housing chamber by removing the cap from the air valve and depressing the valve core.
- d. There are two methods by which the strut chamber may be filled and these are as follows:

Method 1:

1. Remove the valve core from the filler plug at the top of the nose gear strut housing or at the top inboard side of the main gear housing. Allow the filler plug to remain installed.
2. Attach one end of a clean plastic hose to the valve stem of the filler plug and submerge the other end in a container of hydraulic fluid.

NOTE

An air-tight connection is necessary between the plastic tube and the valve stem. Without such a connections, a small amount of air will be sucked into the oleo strut during each sequence, resulting in an inordinate amount of air bubbles and a prolonged filling operation.

3. Fully compress and extend the strut thus drawing fluid from the fluid container and expelling air from the strut chamber. By watching the fluid pass through the plastic hose, it can be determined when the strut is full and no air is present in the chamber.
4. When air bubbles cease to flow through the hose, compress the strut fully and remove the hose from the valve stem.
5. With the strut compressed, remove the filler plug to determine that the fluid level is visible up to the bottom of the filler plug hole.
6. Reinstall the core in the filler plug and apply thread lubricant (Parker No. 6PB) to the threads of the filler plug and install the plug in the top of the strut housing. Torque the plug to 45 foot pounds.

Method 2:

1. Remove the filler plug from the top of the nose gear strut housing or at the top inboard side of the main gear housing.
 2. Raise the strut piston tube until it is fully compressed.
 3. Pour fluid from a clean container through the filler opening until it reaches the bottom of the filler plug hole. (Air pressure type oil container may be helpful.)
 4. Install the filler plug finger tight and extend and compress the strut two or three times to remove air from the housing.
 5. Remove the filler plug, raise the strut to full compression and fill with fluid if needed.
 6. Apply thread lubricant (Parker No. 6PB) to the threads of the filler plug. Reinstall the filler plug and torque to 45 foot pounds.
- e. With the airplane raised, compress and extend the gear strut several times to ascertain that the strut actuates freely. The weight of the gear fork and wheel should extend the strut.
 - f. Clean off overflow of fluid and inflate the strut as described in Paragraph 2-39.
 - g. Check that fluid is not leaking around the strut piston at the bottom of the housing.

2-39. INFLATING OLEO STRUTS. After making certain that an oleo strut has sufficient fluid, attach a strut pump to the air valve and inflate the oleo strut. The strut should be inflated until the correct inches piston is exposed with normal static load (empty weight of the airplane plus full fuel and oil) on the gears (Refer to Paragraph 2-37.) Rock the airplane several times to ascertain that the gear settles back to the correct strut position. (If a strut pump is not available, the airplane may be raised and line pressure from a high pressure air system used. Lower the airplane and while rocking it, let air from the valve to bring the strut down to the proper extension. (Before capping the valve, check for valve core leakage.)

2-40. BRAKE SYSTEM.

2-41. SERVICING BRAKE SYSTEM. The brake system incorporates a hydraulic fluid reservoir through which the brake system is periodically serviced. Fluid is drawn from the reservoir by the brake cylinders to maintain the volume of fluid required for maximum braking efficiency. Spongy brake pedal action is often an indication that the brake fluid reservoir is running low on fluid. Instructions for filling the reservoir are given in Paragraph 2-42. When found necessary to accomplish repairs to any of the brake system components, or to bleed the system, these instructions may be found in Section VII.

2-42. FILLING BRAKE CYLINDER RESERVOIR. The brake cylinder reservoir should be filled to the level marked on reservoir, with the fluid specified in Table II-I. The reservoir, located on the left side of the firewall in the engine compartment, should be checked at every 50-hour inspection and replenish necessary. No adjustment of the brakes is necessary, though they should be checked periodically per instructions given in Section VII.

2-43. DRAINING BRAKE SYSTEM. To drain the brake system, connect a hose to the bleeder fitting on the bottom of the cylinder and place the other end of the line in a suitable container. Open the bleeder and slowly pump the hand brake lever and the desired brake pedal until fluid ceases to flow. To clean the brake system, flush with denatured alcohol.

2-44. TIRES.

2-45. SERVICING TIRES. The tires should be maintained at the pressure specified in Table II-I. When checking tire pressure, examine the tires for wear, cuts, bruises and slippage on the wheel. The tire, tube and wheel should be properly balanced when installed with the index mark on the tire aligned with the index mark on the tube.

2-46. POWER PLANT.

2-47. SERVICING POWER PLANT. Regularly check the engine compartment for oil and fuel leaks, chaffing of lines, loose wires and tightness of all parts. For cleaning of the engine compartment, refer to Paragraph 2-23. Maintenance instructions for the power plant may be found in Section VIII or VIIIA of this manual and in the appropriate manufacturers manuals.

2-48. INDUCTION AIR FILTER.

2-49. REMOVAL OF AIR FILTER. The location of the PA-28R-201 filter is on the left side and just in front of the firewall. The PA-28R-201T filter is located just in front of the firewall above the turbocharger. Remove filter by following procedure:

- a. Remove upper engine cowl.
- b. Loosen studs and carefully move the cover assembly aside.
- c. The filter is now free for removal. Clean or replace the filter as given in Paragraph 2-50.

2-50. SERVICE INSTRUCTION. (CLEANING AND INSPECTION.)

- a. The filter should be cleaned daily when operating in dusty conditions and if any holes or tears are noticed, the filter should be replaced immediately. For replacement filter, refer to Parts Catalog.
- b. Remove the filter element and shake off loose dirt by tapping on a hard surface, being careful not to damage or crease the sealing ends.

CAUTION

Never wash the filter element in any liquid or soak in oil. Never attempt to blow off dirt with compressed air.

- c. The filter housing can be cleaned by wiping with a clean cloth soaked in suitable quick drying type solvent. When the housing is dry, reinstall in accordance with Paragraph 2-51.

2-51. INSTALLATION OF AIR FILTER. After cleaning and inspection, install the filter element and cover in reverse order of removal instructions.

2-52. PROPELLER.

2-53. SERVICING PROPELLER. The spinner, back plate and propeller surfaces should be cleaned and inspected frequently for nicks, scratches, corrosion and cracks. Minor nicks and scratches may be removed as found in Section VIII or VIIIA. The face of each blade should be painted when necessary with a flat paint to retard glare. To prevent corrosion, wipe surfaces with a light oil or wax.

In addition, propellers should be inspected for grease or oil leakage and freedom of rotation on the hub pilot tube. To check freedom of rotation, rock and blade back and forth through the slight freedom allowed by the pitch change mechanism. Lubricate the propeller at 100-hour intervals in accordance with the Lubrication Chart.

Additional service information for the propeller may be found in Section VIII or VIIIA.

2-54. FUEL SYSTEM.

2-55. SERVICING FUEL SYSTEM. At intervals of 50-hours or 90 days, whichever comes first, clean the fuel strainer screen, located in the fuel bowl mounted on the lower left side of the firewall, and on PA-28R-201 only, clean the screen in the inlet side of the injector. Remove and clean the fuel strainer screen in accordance with the instructions outlined in Section IX. Additional fuel system service information may also be found in Section IX. Inspection intervals of the various fuel system components may be found in Section III.

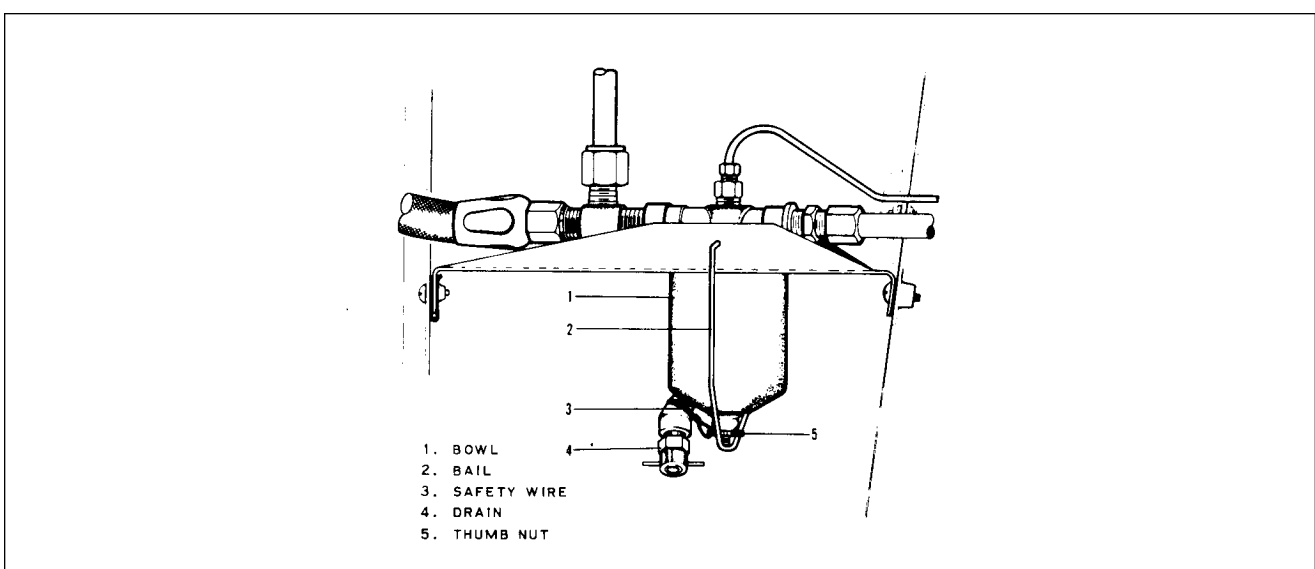

Figure 2-12. Fuel Strainer

2-56. FILLING FUEL TANKS. Observe all required precautions for handling gasoline. Fill the fuel tanks with the fuel as specified on the placard adjacent to the filler neck or in Table II-I. Each wing tank has a capacity of 38 1/2 U.S. gallons, for a total capacity of 77 U.S. gallons. Five U.S. gallons are considered unusable fuel.

2-57. DRAINING MOSITURE FROM FUEL SYSTEM. The fuel tanks and fuel strainer should be drained daily prior to first flight to avoid the accumulation of water or sediment. Each fuel tank is equipped with an individual quick drain located at the lower inboard rear corner of the tank. The fuel strainer with a quick drain valve (refer to Figure 2-12) is located on the lower left side of the firewall. Drain fuel tanks and strainer per the following:

- a. Drain each tank through its individual quick drain located at the lower inboard rear corner of the tank, making sure that enough fuel has been drained to insure that all water and sediment is removed.
- b. Place a container under the fuel strainer drain. Drain the fuel strainer by opening the quick drain on the strainer.
- c. Examine the contents of the container placed under the fuel strainer drain for water and sediment and dispose of the contents.

CAUTION

When draining any amount of fuel, care should be taken to insure that no fire hazard exists before starting engine.

2-58. DRAINING FUEL SYSTEM. Fuel may be drained from the system by opening the valve at the inboard end of each fuel tank. The drain valve requires the drain cup pin to hold valve open. The remaining fuel in the system may be drained through the filter bowl. Any individual tank may be drained by closing the selector valve and then draining as desired.

2-58a FUEL ADDITIVES. Operating the aircraft with fuel anti-icing fuel additive, MIL-1-27686, is approved. It must be uniformly blended with the fuel while refueling, must not exceed .15% by volume of the refueled quantity and must be blended at not less than .10% volume 1 1/2 liquid oz.'s per 10 gallons of fuel would fall within this range. Use a blender supplied by the additive manufacturer. Except for the information contained in this section, the manufacturer's mixing or blending instructions should be carefully followed.

—CAUTION—

Assure that the additive is directed into flowing fuel stream. The additive flow should start after and stop before the fuel flow. Do not permit the concentrated additive to come in contact with the aircraft painted surfaces or the interior surfaces of the fuel tanks.

Some fuels have anti-icing additives preblended in the fuel at the refinery, so no further blending should be performed.

Fuel additive cannot be used as a substitute for preflight draining of the fuel system drains.

2-59. ELECTRICAL SYSTEM.

2-60. SERVICING ELECTRICAL SYSTEM. Servicing the electrical system involves adding distilled water to the battery to maintain correct electrolyte level and checking cable connections and for any spilled electrolyte that would lead to corrosion. The security of all electrical connections should be checked as well as the operation of all lights, general condition of the alternator and starter. All electrical wires should be inspected for chafing and bare wires. For detailed information on this system, refer to Section XI of this manual.

2-61. LUBRICATION.

2-62. OIL SYSTEM. (ENGINE.)

2-63. SERVICING OIL SYSTEM. The engine oil level should be checked before each flight and changed after each 100-hours of engine operation. During oil change the oil screen(s) should be removed and cleaned, and the oil filter cartridge replaced. Replace oil filter at 50-hour intervals. Use a quality brand aviation grade oil of the proper season viscosity. Refer to Tables II-III and II-VI for proper oil grade and specification. For information on the use of detergent oil, on the PA-28R-201 airplanes refer to Paragraph 2-69 and/or Lycoming Service Instruction Letter 1014. Detergent oil that meets Continental Motors Corporation Specification MHS-24, is the only recommended lubricating oil for the PA-28R-201T airplanes.

CAUTION

Do not introduce any trade additive to the basic lubricant unless recommended by the engine manufacturer.

2-64. FILLING OIL SUMP. The oil sump should normally be filled with oil to the mark on the engine dipstick. The quantity of oil required for the engines may be found in Table II-I. The specified grade of oil may be found in Table II-III, the Lubrication Chart, or on the access door. To service the engine with oil, open the access door and remove the oil filler cap.

2-65. DRAINING OIL SUMP. To drain the oil sump, provide a suitable container with a minimum capacity of that required to fill the sump. Remove the engine cowl and on PA-28R-201 airplanes open the oil drain valve by pushing the center of the drain up and turning counterclockwise. This will hold the drain in the open position. On PA-28R-201T airplanes remove the oil drain probe from the clip on the right rear engine baffle. Install suitable hose on probe and insert in quick drain valve located on the underside of the engine. It is recommended the engine be warmed to operating temperature to insure complete draining of the old oil.

—CAUTION—

When replacing the engine oil quick drain, refer to the Piper Parts Catalog for the correct part number. Installation of an incorrect drain could damage the sump or the drain itself. This could lead to loss of engine oil and a possible engine seizure.

2-66. OIL FILTER (FULL FLOW).

- a. The oil filter should be replaced after each 50 hours of engine operation; this is accomplished by removing the lockwire from the bolthead at the end of the filter housing, loosening the cartridge, and removing it from the adapter.

NOTE

Ascertain that oil filter complies with specifications of Continental Aircraft Engine Service Bulletin M75-7. Warranty effectivity is dependent on the use of Continental engine parts, per Continental Aircraft Engine Service Bulletin M75-9.

- b. Before discarding the throw away filter, remove the element for inspection by using a Champion cutter tool, CT-470, available from Champion Spark Plug Co., Toledo, Ohio 43601. It will cut open any spin-on type oil filter for inspection. Examine the material trapped in the filter for evidence of internal engine damage, such as chips or particles from bearings. In new or newly overhauled engines, some small particles of metallic shavings might be found; these are generally of no consequence and should not be confused with particles produced by impacting, abrasion or pressure. Evidence of internal engine damage found in the oil filter justifies further examination to determine the cause.
- c. After the filter has been replaced, tighten the new cartridge with 18 to 20 foot-pounds of torque. Lockwire the bolt head to the loops on the side of the housing, and on Lycoming engines also to the drilled head of the thermostatic valve. Be sure the lockwire is replaced at both the attached bolthead and the thermostatic oil cooler bypass. Use MS-20995-C41 safety wire.

2-67. RECOMMENDATIONS FOR CHANGING OIL. The engine manufacturer recommends that the oil supply be drained and the entire sump filled with fresh oil after each 100 hours of engine operation. Always start and warm the engine to operating temperature before performing an oil change. While draining the oil, the screens should be removed from the crankcase cover and cleaned thoroughly. If sludge deposits are heavy, subsequent oil changes should be made at shorter intervals.

a. Note the following for Continental engines:

1. Detergent oil that meets Continental Motors Corporation Specification MHS-24, is the only recommended lubricating oil.
2. Use SAE-30 or 10W-30 below 40°F and SAE-50 above 40°F. When the average ambient air temperature is approximately at the dividing line, use the lighter oil.

b. Note the following for Lycoming engine:

1. Non-detergent oil that meets MIL-L-6082 specification is recommended by Lycoming. (See Lubrication Chart.)
2. For use of detergent oil note the following: Also refer to the latest revision of Lycoming Service Information No. 1014.

(a) In engines that have been operating on straight mineral oil for several hundred hours, a change to additive oil should be made with a degree of caution, since the cleaning action of some additive oils will tend to loosen sludge deposits and cause plugged oil passages. When an engine has been operating on straight mineral oil and is known to be in excessively dirty condition, the switch to additive or compounded oil should be deferred until after the engine is overhauled.

(b) When changing from straight oil to compound oil, the following precautionary steps should be taken:

- (1) Do not add additive oil to straight mineral oil. Drain the straight mineral oil from the engine and fill with additive oil.
- (2) Do not operate the engine longer than five hours before the first oil change.
- (3) Check all oil screens for evidence of sludge or plugging and change oil every ten hours if sludge conditions are evident. Resume normal oil drain periods after sludge conditions improve.

2-68. LUBRICATION INSTRUCTIONS. Proper lubrication procedures are of immeasurable value both as a means of prolonging the service life of the airplane and as a means of reducing the frequency of extensive and expensive repairs. The periodic application of recommended lubricants to their relevant bearing surfaces, as detailed in the following Paragraphs, together with the observance of cleanliness will insure the maximum efficiency and utmost service of all moving parts. Lubrication instruction regarding the locations, time intervals, and type of lubricants used may be found in the Lubrication Chart. To insure the best possible results from the application of lubricants, the following precautions should be observed:

- a. Use recommended lubricants. Where general purpose lubricating oil is specified, but unavailable, clean engine oil may be used as a satisfactory substitute.
- b. Check the components to be lubricated for evidence of excessive wear and replace them as necessary.
- c. Remove all excess lubricants from components in order to prevent the collection of dirt and sand in abrasive quantities capable of causing excessive wear or damage to bearing surfaces.

NOTE

If the airplane is inactive for long periods of time, it should be lubricated in accordance with Lubrication Chart every 90 days.

2-69. APPLICATION OF OIL. Whenever specific instructions for lubrication of mechanisms requiring lubrication are not available, observe the following precautions:

- a. Apply oil sparingly, never more than enough to coat the bearing surfaces.
- b. Since the control cables are sufficiently coated by the manufacturer, additional protection for the prevention of corrosion is unnecessary.
- c. Squeeze the magneto cam follower felt at regular inspection periods. If oil appears on fingers, do not add oil. If the felt is dry, moisten with light oil.

CAUTION

Be careful not to add too much oil, because the excess will be thrown off during operation and will cause pitting and burning of the magneto points.

2-70. APPLICATION GREASE. Care must be taken when lubricating bearings and bearing surfaces with a grease gun, to insure that gun is filled with new, clean grease of the grade specified for the particular application before applying lubricant to the grease fittings.

- a. Where a reservoir is not provided around a bearing, apply the lubricant sparingly and wipe off any excess.
- b. Remove wheel bearings from the wheel hub and clean thoroughly with a suitable solvent. When repacking with grease, be sure the lubricant enters the space between the rollers in the retainer ring. Do not pack the grease into the wheel hub.
- c. Use extra care when greasing the constant speed propeller hub to avoid blowing the clamp gaskets. Remove one grease fitting and apply grease to the other fitting until fresh grease appears at the hole of the removed fitting.

2-71. WINTERIZATION PLATE. (PA-28R-201 Only.) For winter operations there is a winterization plate kit available. When the ambient temperature is 50° F or less the plate is installed on the inlet opening of the oil cooler plenum chamber. When the plate is not being used it can be stowed on a bracket, provided for this purpose, located on the oil cooler plenum chamber.

(PA-28R-201T Only.) The winterization plate is mounted on the firewall when not in use (temperature is above 50°F). The plate is mounted to the oil cooler baffle when ambient temperature is 50°F or less.

***CHEROKEE ARROW III SERVICE MANUAL**

2-72. LUBRICATION CHARTS. The lubrication charts consists of individual illustrations for the various aircraft systems, and each component to be lubricated is indicated by a number, the type of lubricant and the frequency of application. Special instructions are listed at the beginning of the lubrication charts and with the applicable component illustration.

NOTE

When the average ambient air temperature is approximately at the dividing line, use the lighter oil.

***CHEROKEE ARROW III SERVICE MANUAL**

TABLE II-III. RECOMMENDED ENGINE LUBRICATING OILS

PA-28R-201			
Average Grade Oil	Average Ambient Air Temperature	Oil Inlet Temperatures	
		Desired	Maximum
SAE 50	Above 60°F (16°C)	180°F (82°C)	245°F (118°C)
SAE 40	30°F to 90°F (-1°C to 32°C)	180°F (82°C)	245°F (118°C)
SAE 30	0°F to 70°F (-17°C to 20°C)	170°F (77°C)	225°F (107°C)
SAE 20	Below 10°F (12°C)	160°F (71°C)	210°F (99°C)
PA-28R-201T			
Average Grade Oil	Average Ambient Air Temperature		
SAE 50	Above 40°F		
SAE 30 or 10-W-30	Below 40°F		
NOTE			
<i>When the average ambient air temperature is approximately at the dividing line, use the lighter oil.</i>			

***CHEROKEE ARROW III SERVICE MANUAL**

TABLE II-IV. THREAD LUBRICANTS

TYPE OF LINE	TYPE OF LUBRICANT
Brakes	MIL-H-5606A
Freon	TT-A-580 or MIL-T-5544, Anti-Seize Compound
Fuel	MIL-T-5544, Anti-Seize, Graphite Petrolatum
Landing Gear (Air Valve)	6PB Parker
Oil	MIL-G-6032, Lubricating Grease (Gasoline and Oil Resistant)
Pitot and Static	TT-A-580 (JAN-A-669), Anti-Seize Compound (White Lead Base)
<p style="text-align: center;">NOTE</p> <p style="text-align: center;"><i>Lubricate engine fittings only with the fluid contained in the particular lines.</i></p>	

TABLE II-V. CONVERSION TABLES

1. These charts contain the various conversion data that may be useful when figuring capacities, lengths, temperatures, and various weights and measures from the English system values to the metric system values or back again.
2. The English system is in use by England and the United States. All other countries use the metric system.
3. Procedure for Converting Inches to Millimeters. (Refer to Table II-V.)
 - A. Example: Convert 1.5 inches to millimeters.
 - (1) Read down inches column to 1. inches.
 - (2) Read across top inch column to 0.5.
 - (3) Read down and across to find millimeters (1.5 inches is 38.10 millimeters).
4. Procedure for Converting Fahrenheit ($^{\circ}$ F) and Celsius ($^{\circ}$ C), (Centigrade) Temperature.
 - A. Read number in middle column, if in degrees Celsius ($^{\circ}$ C), read Fahrenheit equivalent in right-hand column. If in degrees Fahrenheit ($^{\circ}$ F), read Celsius equivalent in left-hand column.
 - (1) 70° F = 21.1° C.
 - (2) 30° C = 86.0° F.

CHEROKEE ARROW III SERVICE MANUAL

TABLE II-V. CONVERSION TABLES (cont)

INCHES TO MILLIMETER										
INCHES	0.0000	0.0001	0.0002	0.0003	0.0004	0.0005	0.0006	0.0007	0.0008	0.0009
	MILLIMETER									
0.000		0.0025	0.0050	0.0076	0.0101	0.0127	0.0152	0.0177	0.0203	0.0228
0.001	0.0254	0.0279	0.0304	0.0330	0.0355	0.0381	0.0406	0.0431	0.0457	0.0482
0.002	0.0508	0.0533	0.0558	0.0584	0.0609	0.0635	0.0660	0.0685	0.0711	0.0736
0.003	0.0762	0.0812	0.0838	0.0863	0.0889	0.0914	0.0939	0.0965	0.0965	0.0990
0.004	0.1016	0.1041	0.1066	0.1092	0.1117	0.1143	0.1168	0.1193	0.1219	0.1244
0.005	0.1270	0.1295	0.1320	0.1346	0.1371	0.1397	0.1422	0.1447	0.1447	0.1498
0.006	0.1524	0.1549	0.1574	0.1600	0.1625	0.1651	0.1676	0.1701	0.1727	0.1752
0.007	0.1778	0.1803	0.1828	0.1854	0.1879	0.1905	0.1930	0.1955	0.1981	0.2006
0.008	0.2032	0.2057	0.2082	0.2108	0.2133	0.2159	0.2184	0.2209	0.2235	0.2260
0.009	0.2286	0.2311	0.2336	0.2362	0.2387	0.2413	0.2438	0.2463	0.2489	0.2514
INCHES	0.000	0.001	0.002	0.003	0.004	0.005	0.006	0.007	0.008	0.009
	MILLIMETER									
0.00		0.025	0.050	0.076	0.101	0.127	0.152	0.177	0.203	0.228
0.01	0.254	0.279	0.304	0.330	0.355	0.381	0.406	0.431	0.457	0.482
0.02	0.508	0.533	0.558	0.584	0.609	0.635	0.660	0.685	0.711	0.736
0.03	0.762	0.787	0.812	0.838	0.863	0.889	0.914	0.939	0.965	0.990
0.04	1.016	1.041	1.066	1.092	1.117	1.143	1.168	1.193	1.219	1.244
0.05	1.270	1.295	1.320	1.346	1.371	1.397	1.422	1.447	1.473	1.498
0.06	1.524	1.549	1.574	1.600	1.625	1.651	1.676	1.701	1.727	1.752
0.07	1.778	1.803	1.828	1.854	1.879	1.905	1.930	1.955	1.981	2.006
0.08	2.032	2.057	2.082	2.108	2.133	2.159	2.184	2.209	2.235	2.260
0.09	2.286	2.311	2.336	2.362	2.387	2.413	2.438	2.463	2.489	2.514
INCHES	0.00	0.01	0.02	0.03	0.04	0.05	0.06	0.07	0.08	0.09
	MILLIMETER									
0.0		0.254	0.508	0.762	0.016	1.270	1.524	1.778	2.032	2.286
0.1	2.540	2.794	3.048	3.302	3.556	3.810	4.064	4.318	4.572	4.826
0.2	5.080	5.334	5.558	5.842	6.096	6.350	6.604	6.858	7.112	7.366
0.3	7.620	7.874	8.128	8.382	8.636	8.890	9.144	9.398	9.652	9.906
0.4	10.160	10.414	10.668	10.922	11.176	11.430	11.684	11.938	12.192	12.446
0.5	12.700	12.954	13.208	13.462	13.716	13.970	14.224	14.478	14.732	14.986
0.6	15.240	15.494	15.748	16.002	16.256	16.510	16.764	17.018	17.272	17.526
0.7	17.780	18.034	18.288	18.542	18.796	19.050	19.304	19.558	19.812	20.066
0.8	20.320	20.574	20.828	21.082	21.336	21.590	21.844	22.098	22.352	22.606
0.9	22.860	23.114	23.368	23.622	23.876	24.130	24.384	24.638	24.892	25.146

CHEROKEE ARROW III SERVICE MANUAL

TABLE II-V. CONVERSION TABLES (cont)

INCHES TO MILLIMETER

INCHES	0.00	0.1	0.2	0.3	0.4	0.5	0.6	0.7	0.8	0.9
	MILLIMETER									
0.		2.54	5.08	7.62	10.16	12.70	15.24	17.78	20.32	22.86
1.	25.40	27.94	30.48	33.02	35.56	38.10	40.64	43.18	45.72	48.26
2.	50.80	53.34	55.88	58.42	60.96	63.50	66.04	68.58	71.12	73.66
3.	76.20	78.74	81.28	83.82	86.36	88.90	91.44	93.98	96.52	99.06
4.	101.60	104.14	106.68	109.22	111.76	114.30	116.84	119.38	121.92	124.46
5.	127.00	129.54	132.08	134.62	137.16	139.70	142.24	144.78	147.32	149.86
6.	152.40	154.94	157.48	160.02	162.56	165.10	167.64	170.18	172.72	175.26
7.	177.80	180.34	182.88	185.42	187.96	190.50	193.04	195.58	198.12	200.66
8.	203.20	205.74	208.28	210.82	213.36	215.90	218.44	220.98	223.52	226.06
9.	228.60	231.14	233.68	236.22	238.76	241.30	243.84	246.38	248.92	251.46

THIS SPACE INTENTIONALLY LEFT BLANK

CHEROKEE ARROW III SERVICE MANUAL

TABLE II-V. CONVERSION TABLES (cont)

CENTIGRADE - FAHRENHEIT CONVERSION TABLE

Example: To convert 20°C, to Fahrenheit, find 20 in the center column headed (°F - °C); then read 68.0°F, in the column (°F) to the right. To convert 20°F, to Centigrade; find 20 in the center column and read -6.67°C, in the (°C) column to the left.

°C	°F - °C	°F	°C	°F - °C	°F
-56.7	-70	-94.0	104.44	220	428.0
-51.1	-60	-76.0	110.00	230	446.0
-45.6	-50	-58.0	115.56	240	464.0
-40.0	-40	-40.0	121.11	250	482.0
-34.0	-30	-22.0	126.67	260	500.0
-38.9	-20	-4.0	132.22	270	518.0
-23.3	-10	14.0	137.78	280	536.0
-17.8	0	32.0	143.33	290	554.0
-12.22	10	50.0	148.89	300	572.0
-6.67	20	68.0	154.44	310	590.0
-1.11	30	86.0	160.00	320	608.0
4.44	40	104.0	165.56	330	626.0
10.00	50	122.0	171.11	340	644.0
15.56	60	140.0	176.67	350	662.0
21.11	70	158.0	182.22	360	680.0
26.67	80	176.0	187.78	370	698.0
32.22	90	194.0	193.33	380	716.0
27.78	100	212.0	198.89	390	734.0
43.33	110	230.0	204.44	400	752.0
38.89	120	248.0	210.00	410	770.0
54.44	130	266.0	215.56	420	788.0
60.00	140	284.0	221.11	430	806.0
65.56	150	302.0	226.67	440	824.0
71.00	160	320.0	232.22	450	842.0
76.67	170	338.0	257.78	460	860.0
82.22	180	356.0	243.33	470	878.0
87.78	190	374.0	248.89	480	896.0
93.33	200	392.0	254.44	490	914.0
98.89	210	410.0	260.00	500	932.0

CHEROKEE ARROW III SERVICE MANUAL

TABLE II-V. CONVERSION TABLES (cont)

MULTIPLY	BY	TO OBTAIN	MULTIPLY	BY	TO OBTAIN
CENTIMETERS	0.3937 0.03281	IN. FT.	KILOGRAMS	2.205 35.27 1000	LB. OZ. GRAMS
CU. CENTIMETERS	0.001 0.06102 0.0002642	LITERS CU. IN. U.S. GAL.	LITERS	1000 61.03 0.03532 0.2642 0.22 1.057	CU. CM. CU. IN. CU. FT. U.S. GAL. IMPERIAL GAL. QUARTS
CU. FT.	28.320 1.728 7.481 28.32	CU. CM CU. IN. U.S. GAL. LITERS	METERS	39.37 3.281 1000	IN. FT. MM.
CU. IN.	16.39 0.01639 0.004329 0.01732	CU. CM LITERS U.S. GAL. QUARTS	METER-KILOGRAM	7.233 9.807	FT.-LB. JOULES
CU. METERS	1000000 35.314 61.023 264.17 999.97	CU. CM CU. FT. CU. IN. GAL. LITERS	OUNCES, AVDP	0.0625 28.35 437.5	LB., AVDP GRAMS GRAINS
FEET	0.3048 12.000 304.8 0.3333	METERS MILS MM. YARDS	OUNCES, FLUID	29.57 1.805	CU. CM. CU. IN.
FT.-LB.	0.1383 0.001285 0.000000376	M-KG BTU KW-HR	LB., AVDP	453.6 7000 16.0	GRAMS GRAINS OUNCES
FLUID OZ.	8 29.6	DRAM CU. CM	SQUARE INCH	6.4516	SQ. CM.
GAL., IMPERIAL	277.4 1.201 4.546	CU. IN. U.S. GAL. LITERS	POUND PER SQUARE INCH (PSI)	0.0703	KG.-CM SQUARED
GAL., U.S. DRY	268.8 0.1556 1.164 4.405	CU. IN. CU. FT. U.S. GAL., LIQ. LITERS	STATUTE MILE	1.609 0.8684	KILOMETER NAUTICAL MILE
GAL., U.S. LIQ.	231.0 0.1337 3.785 0.8327 128	CU. IN. CU. FT. LITERS IMPERIAL GAL. FLUID OZ.	NAUTICAL MILE	1.151	STATUTE MILE
IN.	2.540 .08333	CM. FT.	QUART	.9463	LITER
JOULES	0.000948 0.7376	BTU FT.-LB.	MILLIMETER	1000	MICRON
			MICRON	0.001 0.000039	MILLIMETER INCH
			INCH POUNDS	11.521	METER GRAMS
			INCH OUNCES	0.72	METER GRAMS
			POUNDS	0.453	KILOGRAMS

CHEROKEE ARROW III SERVICE MANUAL

TABLE II-V. CONVERSION TABLES (cont)

Decimal/Millimeter Equivalents of Drill Sizes From 1/2" to No. 80

Size	Decimal Equiv.	Millimeter Equiv.	Size	Decimal Equiv.	Millimeter Equiv.	Size	Decimal Equiv.	Millimeter Equiv.	Size	Decimal Equiv.	Millimeter Equiv.
1/2	0.500	12.7000	G	0.261	6.6294	5/32	0.1562	3.9687	51	0.067	1.7018
31/64	0.4843	12.3031	F	0.257	6.5278	23	0.154	3.9116	52	0.0635	1.6129
15/32	0.4687	11.9062	E-1/4	0.250	6.3500	24	0.152	3.8608	1/16	0.0625	1.5875
29/64	0.4531	11.5094	D	0.246	6.2484	25	0.1495	3.7973	53	0.0595	1.5113
7/16	0.4375	11.1125	C	0.242	6.1468	26	0.147	3.7338	54	0.055	1.397
27/64	0.4218	10.7156	B	0.238	6.0452	27	0.144	3.6576	55	0.052	1.3208
Z	0.413	10.4902	15/64	0.2343	5.9531	9/64	0.1406	3.5719	3/64	0.0468	1.1906
13/32	0.4062	10.3187	A	0.234	5.9436	28	0.1405	3.5687	56	0.0465	1.1811
Y	0.404	10.2616	1	0.228	5.7912	29	0.136	3.4544	57	0.043	1.0922
X	0.397	10.0838	2	0.221	5.6134	30	0.01285	3.2639	58	0.042	1.0668
25/64	0.3906	9.9212	7/32	0.2187	5.5562	1/8	0.125	3.1750	59	0.041	1.0414
W	0.386	9.8044	3	0.213	5.4102	31	0.120	3.048	60	0.040	1.016
V	0.377	9.5758	4	0.209	5.3086	32	0.116	2.9464	61	0.039	0.9906
3/8	0.375	9.5250	5	0.2055	5.2197	33	0.113	2.8702	62	0.038	0.9652
U	0.368	9.3472	6	0.204	5.1816	34	0.111	2.8194	63	0.037	0.9398
23/64	0.3593	9.1262	13/64	0.2031	5.1594	35	0.110	2.794	64	0.036	0.9144
T	0.358	9.1281	7	0.201	5.1054	7/64	0.1093	2.7781	65	0.035	0.899
S	0.346	8.7884	8	0.199	5.0546	36	0.1065	2.7051	66	0.033	0.8382
11/32	0.3437	8.7300	9	0.196	4.9784	37	0.104	2.6416	1/32	0.0312	0.7937
R	0.339	8.6106	10	0.1935	4.9149	38	0.1015	2.5781	67	0.032	0.8128
Q	0.332	8.4328	11	0.191	4.8514	39	0.0995	2.5273	68	0.031	0.7874
21/64	0.3281	8.3337	12	0.189	4.8006	40	0.098	2.4892	69	0.029	0.7366
P	0.323	8.2042	3/16	0.1875	4.7625	41	0.096	2.4384	70	0.028	0.7112
O	0.316	8.0264	13	0.185	4.699	3/32	0.0937	2.3812	71	0.026	0.6604
5/16	0.3125	7.9375	14	0.182	4.6228	42	0.0935	2.3749	72	0.025	0.635
N	0.302	7.6708	15	0.180	4.572	43	0.089	2.2606	73	0.024	0.6096
19/64	0.2968	7.5387	16	0.177	4.4958	44	0.086	2.1844	74	0.0229	0.58166
M	0.295	7.4930	17	0.173	4.3942	45	0.082	2.0828	75	0.021	0.5334
L	0.290	7.3660	11/64	0.1718	4.3656	46	0.081	2.0574	76	0.020	0.508
9/32	0.2812	7.1425	18	0.1695	4.3053	47	0.0785	1.9939	77	0.018	0.4572
K	0.281	7.1374	19	0.166	4.2164	5/64	0.0781	1.9844	1/64	0.0156	0.3969
J	0.277	7.0358	20	0.161	4.0894	48	0.076	1.9304	78	0.016	0.4064
I	0.272	6.9088	21	0.159	4.0386	49	0.073	1.8542	79	0.0145	0.3683
H	0.266	6.7564	22	0.157	3.9878	50	0.070	1.778	80	0.0135	0.3429
17/64	0.2656	6.7462									

DRILL SIZES AVAILABLE

Drill may be obtained in regular sizes to a 4 inch diameter, and increase in 64ths of an inch. The regular metric drills vary from 2 to 76mm and increase in 0.5mm variations.

***CHEROKEE ARROW III SERVICE MANUAL**

TABLE II-VI. LUBRICATION SPECIFICATION

LUBRICANT	SPECIFICATION	PRODUCT	VENDOR
PA-28R-201T (Continental) Lubricating oil, aircraft reciprocating engine (piston) grade as specified SAE 50 above 40°F ambient air (S.L.) SAE 30 or 10-W-30 below 40°F ambient air (S.L.)	Teledyne Continental Motors Specification MHS-24A	BP Aero Oil D65/80	BP (North America) Ltd., 620 Fifth Ave., New York, New York 10020
		Castrolaero AD Oil	Castrol Oils, Inc., Castrol Limited, 254-266 Doremus Avenue, Newark, New Jersey 07105
		Esso Aviation Oil Enco Aviation Oil	Humble Oil and Refining Company, P.O. Box 3, New Toronto Postal Station, Toronto, Ontario
		Phillips 66 Aviation Oil, Type A	Phillips Petroleum Company, Bartlesville, Oklahoma 74003
		Aeroshell Oil W	Shell Oil Company, 50 West 50th St., New York, New York 10020
		Sinclair Avoil 20W-40 Oil	Sinclair Refining Company, 600 Fifth Ave., New York, New York 10020
PA-28R-201 (Lycoming) Lubricating oil, aircraft reciprocating engine (piston) grade as specified SAE 50 above 60°F air temp. SAE 40 30° to 90~1F air temp. SAE 30 0° to 70°F air temp. SAE 20 below 10°F air temp.	MIL-L-6082	Texaco Aircraft Engine Oil Premium AD	Texaco Inc., 135 East 42nd St., New York, New York 10017
		Formula LB-1123	Atlantic Richfield Company, 400 East Sibley Blvd., Harvey, Illinois 60426
		Castrolaero 113 (Grade 1065)	Castrol Oils, Inc., Continental Plaza, Hackensack, New Jersey 07601
		Chevron Aviation Oil-65	Chevron Oil Company, Eastern Division, 1200 State St., Perth Amboy, New Jersey 08861
		Mobil Aero White Band AVREX 101/1065	Mobil Oil Corp., 150 E. 42nd St., New York, New York 10017
		Phillips 66 Aviation Engine Oil, Grade 1065	Phillips Petroleum Company, Bartlesville, Oklahoma 74003
PA-28R-201 (Lycoming) Lubricating oil, aircraft reciprocating engine (piston) grade as specified SAE 50 above 60°F air temp. SAE 40 30° to 90~1F air temp. SAE 30 0° to 70°F air temp. SAE 20 below 10°F air temp.	MIL-L-6082	Aeroshell Oil 65	Shell Oil Company, One Shell Plaza, Houston, Texas 77002
		Texaco Aircraft Engine Oil 65 (TL-8973)	Texaco Inc., 135 East 42nd St., New York, New York 10017

***CHEROKEE ARROW III SERVICE MANUAL**

TABLE II-VI. LUBRICATION SPECIFICATION (cont.)

LUBRICANT	SPECIFICATION	PRODUCT	VENDOR
Grease, Aircraft, General Purpose, Wide Temperature Range	MIL-G-81322	Mobilgrease 28	Mobil Oil Corp., Shoreham Building, Washington, D.C. 20005
		Aeroshell Grease 22	Shell Oil Company, 50 West 50th St., New York, New York 10020
		Royco 22S	Royal Lubricants Company, River Road, Hanover, New Jersey 07936
Grease, High Temperature Aircraft		Marfak All Purpose Grease	Texaco Inc., 135 East 42nd St., New York, New York 10017
		Mobil 77 or Mobilux EP2	Mobil Oil Corp., Shoreham Building, Washington, D.C. 20005
		Shell Alvania EP Grease 2	Shell Oil Company, 50 West 50th St., New York, New York 10020
Grease, High & Low Temperature, Waterproof		Aero Lubriplate Mag-1	Fiske Bros. Refining Company, 129 Lochwood, Newark, New Jersey 07105
Fluorocarbon Release Agent Dry Lubricant	MIL-L-60326	MS-122	Miller-Stephenson Chemical Co. Inc., Danbury, Connecticut 06810
Lubricating Oil, General Purpose, Low Temperature	MIL-L-7870	Caltex Low Temp. Oil	Caltex Oil Products Company, New York, New York
		Sinclair Aircraft Orbitlube	Sinclair Refining Company, 600 Fifth Ave., New York, New York 10020
		1692 Low Temp. Oil	Texaco Inc., 135 East 42nd St., New York, New York 1 W17

***CHEROKEE ARROW III SERVICE MANUAL**

TABLE II-VI. LUBRICATION SPECIFICATION (cont.)

LUBRICANT	SPECIFICATION	PRODUCT	VENDOR
Hydraulic Fluid (Brakes and Shock Struts)	MIL-H-5606A	3126 Hydraulic Oil	Exxon Company, U.S.A. Box 2180, Houston, Texas 77001
		PED 3337	Standard Oil of California, 225 Bush St., San Francisco, California 94120
		Aero-HF	Mobil Oil Corp., 150 East 42nd St., New York, New York 1 0017
Grease, Aircraft and Instrument, Gear and Actuator Screw	MIL-G-23827	Supermil Grease No. A72832	American Oil Company, 165 N. Canal, Chicago, Illinois 60606
		Royco 27A	Royal Lubricants Company, River Road, Hanover, New Jersey 07936
		Aeroshell Grease 7	Shell Oil Company, 50 West 50th St., New York, New York 10020
		BP Aero Grease 31B	BP Trading Limited, Moore Lane, Britannic House, London E.C.2 England
		Castrolase A1	Castrol Oils Inc., Newark, New Jersey
O-Ring Lubricant		Parker O-Lube	Parker Seal Company, 2360 Palumbo Drive, Lexington, Kentucky 40509
Silicone, Compound	MIL-C-21567	Dow Corning 6 Compound	Dow Corning Corp., Midland, Michigan

SPECIAL LUBRICATION INSTRUCTIONS

1. **BEARINGS AND BUSHINGS - CLEAN EXTERIOR WITH A DRY TYPE SOLVENT BEFORE LUBRICATING .**
2. **LUBRICATION POINTS - WIPE ALL LUBRICATION POINTS CLEAN OF OIL GREASE, OIL, DIRT, ETC., BEFORE LUBRICATING.**

NOTES

1. **SEE THE LATEST REVISION OF LYCOMING SERVICE INSTRUCTIONS NO. 1014 FOR USE OF DETERGENT OIL WITH LYCOMING ENGINE.**

CAUTIONS

1. **DO NOT USE HYDRAULIC FLUID WITH A CASTOR OIL OR ESTER BASE.**
2. **DO NOT OVER LUBRICATE COCKPIT CONTROLS.**
3. **DO NOT APPLY LUBRICANT TO RUBBER PARTS.**
4. **DO NOT LUBRICATE CABLES: THIS CAUSES SLIPPAGE.**

***CHEROKEE ARROW III SERVICE MANUAL**

COMPONENT	LUBRICANT	FREQUENCY
1. MAIN GEAR PIVOT POINTS	MIL-G-23827	100 HRS
2. MAIN GEAR DOOR HINGE	MIL-L-7870	100 HRS
3. MAIN GEAR TORQUE LINKS	MIL-L7870	100 HRS
4. EXPOSED OLEO STRUT MAIN		
5. MAIN GEAR WHEEL BEARINGS	MIL-L-60326 TEXACO MARFAX ALL PURPOSE GREASE OR MOBIL GREASE 77 (OR MOBIL EP2 GREASE)	100 HRS
6. MAIN GEAR DOOR CONTROL ROD ENDS	MIL-L7870	100 HRS
7. MAIN GEAR SIDE BRACE LINK ASSEMBLY	MIL-LG-23827	100 HRS
8. UPPER SIDE BRACE SWIVEL FITTING	MIL-G-23827	100 HRS
9. MAIN GEAR DOWNLOCK ASSEMBLY RETRACTION FITTING AND CYLINDER ATTACHMENT POINTS	MIL-L-7870	100 HRS
10. OLEO STRUT FILLER POINT (MAIN GEAR)	MIL-H-5606	AS REQUIRED
11. HYDRAULIC PUMP RESERVOIR	MIL-H-5606	100 HRS
12. BRAKE RESERVOIR	MIL-H-5606	100 HRS

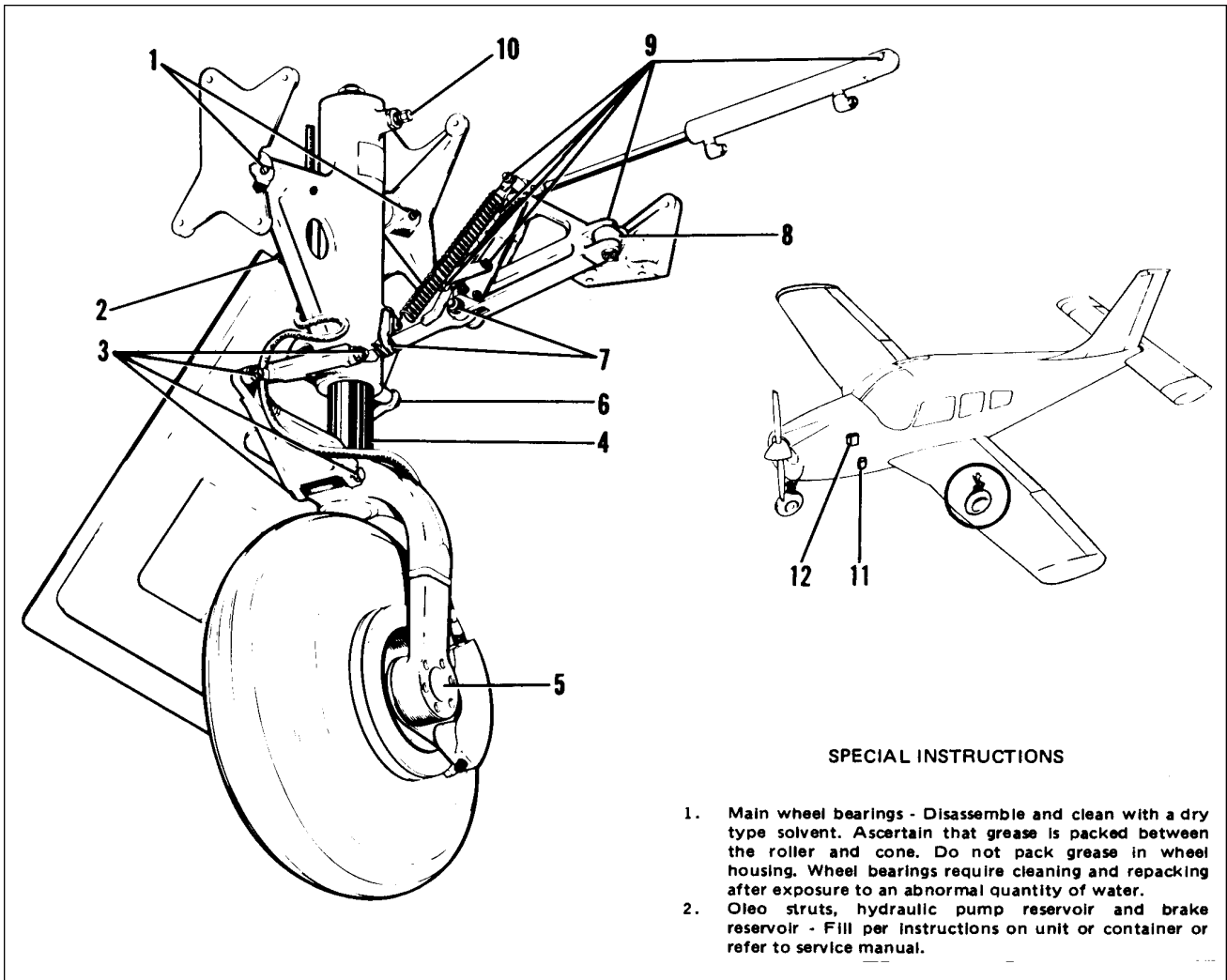

Figure 2-13. Lubrication Chart (Landing Gear, Main)

***CHEROKEE ARROW III SERVICE MANUAL**

COMPONENT	LUBRICANT	FREQUENCY
1. NOSE GEAR STRUT HOUSING GREASE FITTING	MIL-G-23827	100 HRS.
2. NOSE GEAR PIVOT POINT AND HYDRAULIC CYLINDER ROD END	MIL-L-7870	100 HRS
3. NOSE GEAR DOOR RETRACTION MECHANISM	MIL-L-7870	100 HRS
4. NOSE GEAR DOOR HINGES	MIL-L-7870	100 HRS
5. EXPOSED OLEO STRUT	MIL-L-60326	100 HRS
6. NOSE WHEEL BEARINGS	TEXACO MARFAX ALL PURPOSE GREASE OR MOBIL MOBIL GREASE 77 (OR MOBIL EP2 GREASE)	100 HRS
7. NOSE GEAR DRAG LINK ASSEMBLIES	MIL-L-7870	100 HRS
8. NOSE GEAR TORQUE LINK ASSEMBLY AND STRUT HOUSING	MIL-G-23827	100 HRS
9. DOWNLOCK, ROLLER TENSION SPRING, SHIMMY DAMPENER AND ALIGNING ROLLER PIVOT POINTS	MIL-L-7870	100 HRS
10. STEERING BELLCRANK PIVOT POINTS AND ROD ENDS	MIL-L-7870	100 HRS
11. NOSE GEAR OLEO STRUT FILLER POINT	MIL-H-5606	AS REQUIRED
12. BUNGEE SPRING	MIL-G-7711	100 HRS
13. FIREWALL BUNGEE SEAL	AERO LUBRIPLATE OR MAG-1	100 HRS

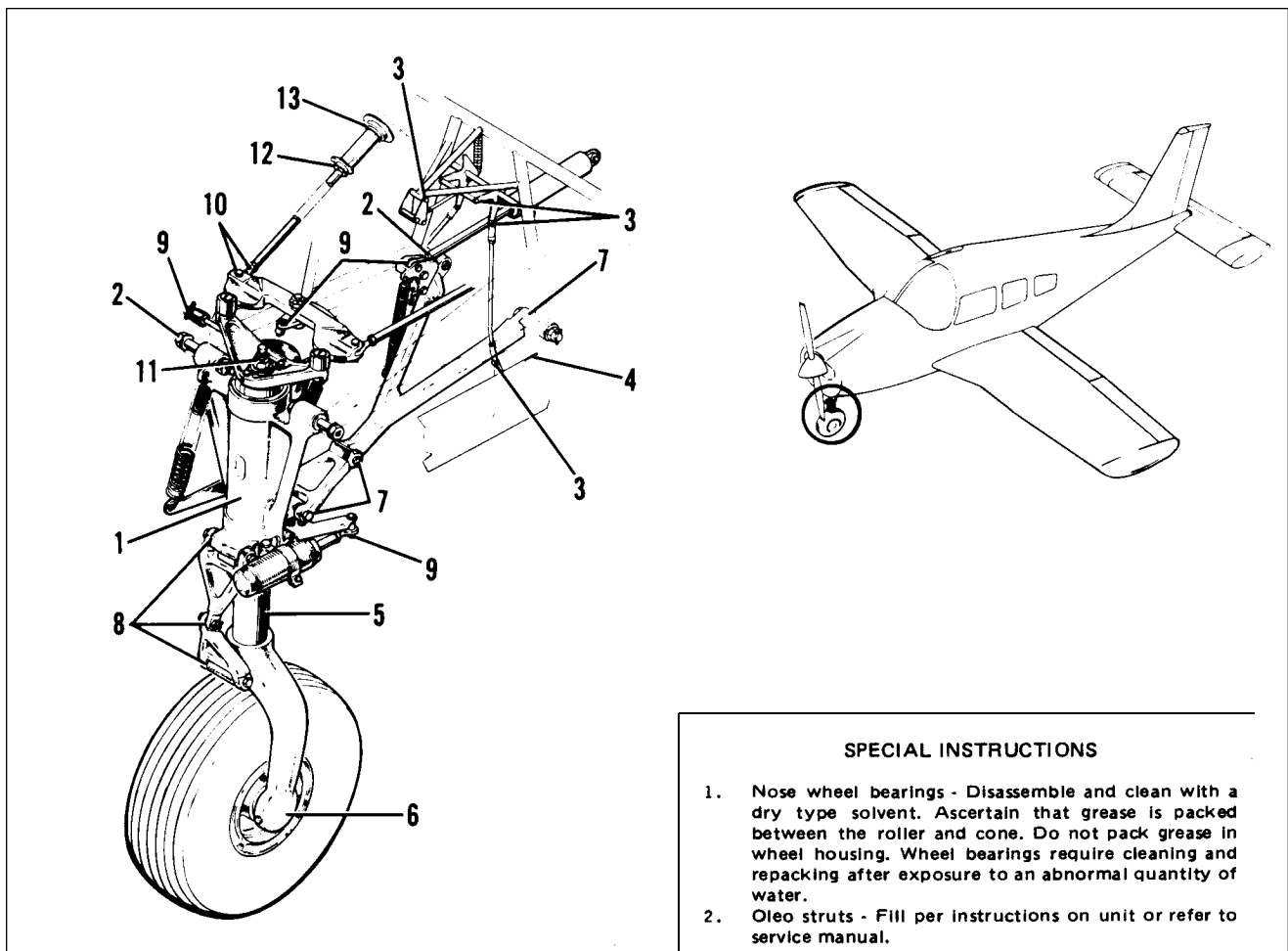

Figure 2-14. Lubrication Chart (Landing Gear, Nose)

***CHEROKEE ARROW III SERVICE MANUAL**

- CAUTION -

Do not lubricate control wheel shaft or bushing. Clean only using alcohol or other suitable solvent.

COMPONENT	LUBRICANT	FREQUENCY
1. AILERON HINGE PINS	MIL-L-7870	100 HRS
2. FLAP HINGE BEARINGS	MIL-L-7870	100 HRS
3. STABILATOR HINGE PINS	MIL-L-7870	100 HRS
4. RUDDER HINGE BEARINGS	MIL-L-7870	100 HRS
5. CONTROL CABLE PULLEYS	MIL-L-7870	100 HRS
6. TRIM CONTROL WHEEL	MIL-L-7870	100 HRS
7. O-RING, CONTROL SHAFT BUSHING	PARKER O-RING* LUBRICANT	AS REQUIRED
8. TEE BAR PIVOT POINT	MIL-L-7870	100 HRS
9. CONTROL COLUMN CHAIN	MIL-L-7870	100 HRS
10. CONTROL COLUMN FLEX JOINTS AND SPROCKET	MIL-L-7870	100 HRS
11. STABILATOR CONTROL	MIL-L-7870	100 HRS

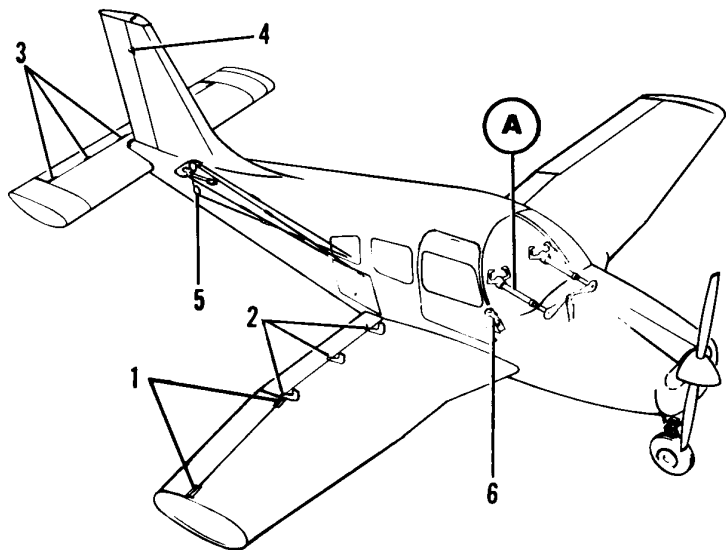
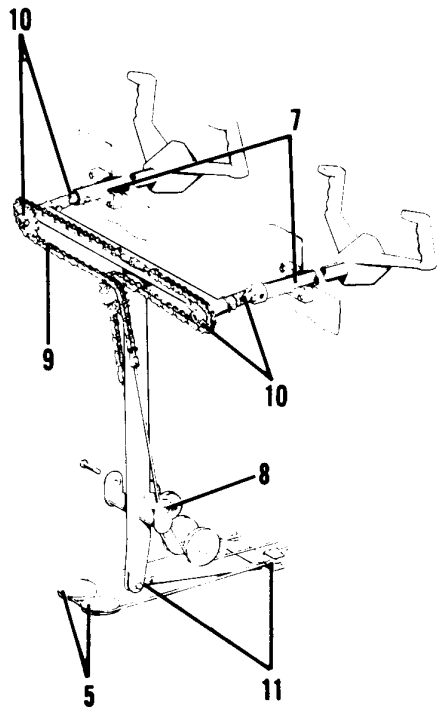

***SPECIAL INSTRUCTIONS**

Disassemble "O" ring retainer plates from instrument panel; lubricate "O" ring and reassemble.

Figure 2-15. Lubrication Chart (Control system)

***CHEROKEE ARROW III SERVICE MANUAL**

COMPONENT	LUBRICANT	FREQUENCY
1. FLAP TORQUE TUBE BEARING BLOCKS	MIL-L-7870	100 HRS
2. FLAP CONTROL ROD END BEARINGS	MIL-L-7870	100 HRS
3. FLAP HANDLE PIVOT POINT, LOCK MECHANISM AND TURNBUCKLE END	MIL-L-7870	100 HRS
4. FLAP RETURN AND TENSION CHAINS	MIL-L-7870	100 HRS
5. AILERON CONTROL, ROD END BEARINGS	MIL-L-7870	100 HRS
6. AILERON BELLCRANK CABLE ENDS	MIL-L-7870	100 HRS

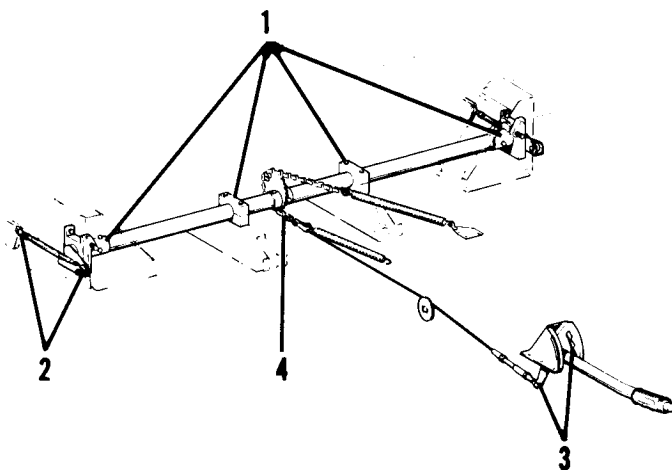
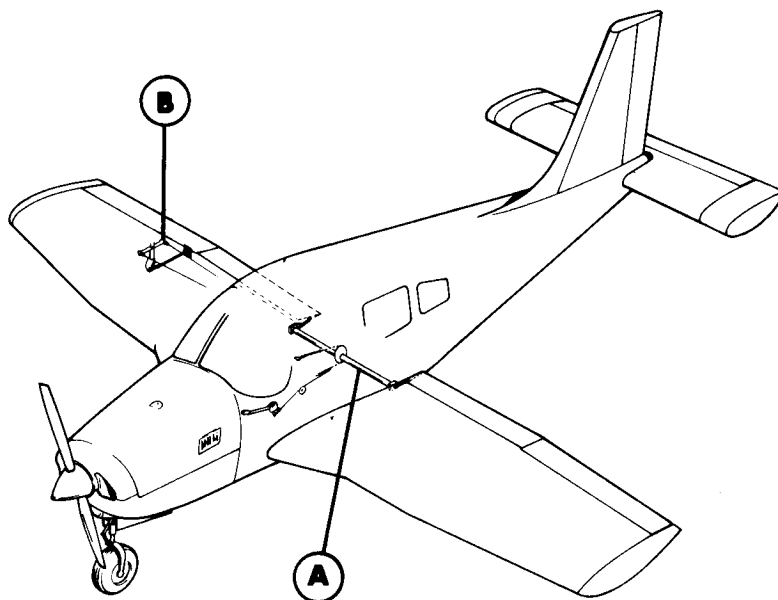

SKETCH A

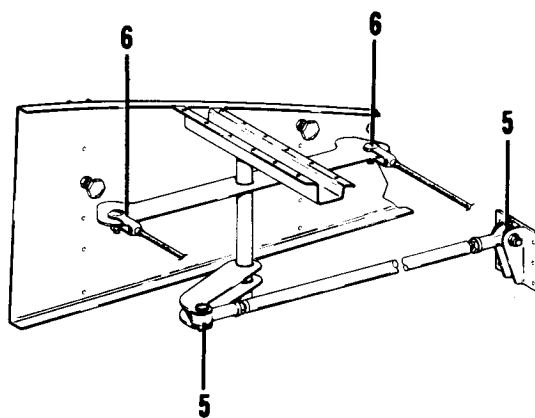

SKETCH B

Figure 2-16. Lubrication Chart (Control System) (cont.)

***CHEROKEE ARROW III SERVICE MANUAL**

COMPONENT	LUBRICANT	FREQUENCY
1. RUDDER TUBE BEARING BLOCKS	MIL-L-60326	100 HRS
2. TOE BRAKE CYLINDER ATTACHMENTS	MIL-L-7870	100 HRS
3. RUDDER TUBE CONNECTIONS	MIL-L-7870	100 HRS
4. BRAKE ROD ENDS	MIL-L-7870	100 HRS

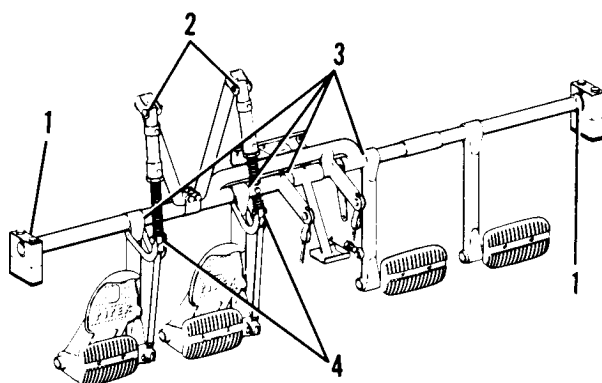
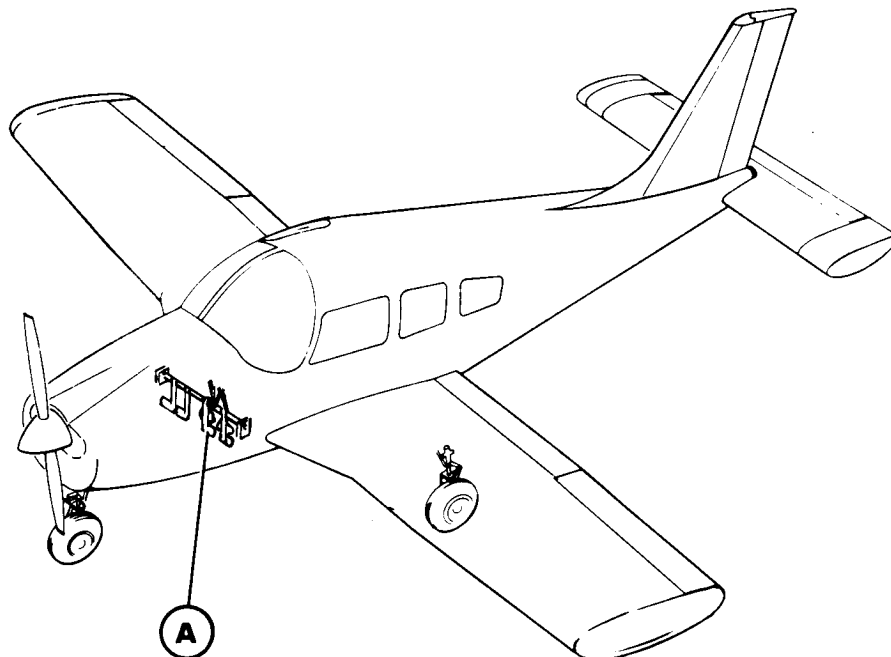

SKETCH A

Figure 2-17. Lubrication Chart (Control System) (cont.)

***CHEROKEE ARROW III SERVICE MANUAL**

COMPONENT	LUBRICANT	FREQUENCY
1. RUDDER ARM CABLE ENDS	MIL-L-7870	100 HRS
2. STABILATOR TRIM SCREW	AERO LUBRIPLATE OR MAG-1 FISKE BROS. REFINING CO.	100 HRS
3. STABILATOR SCREW/TAB LINKS	MIL-L-7870	100 HRS
4. STABILATOR HINGE POINTS	MIL-L-7870	100 HRS
5. RUDDER TRIM ASSEMBLY	MIL-L-7870	100 HRS

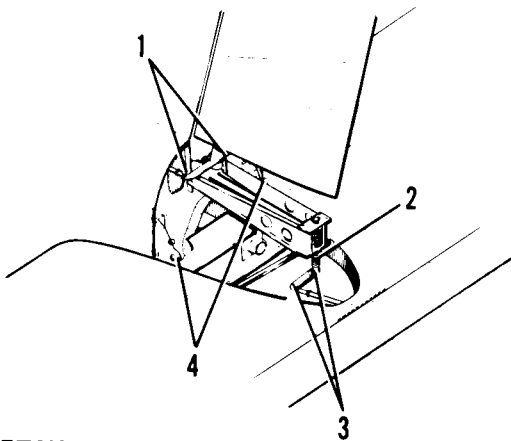
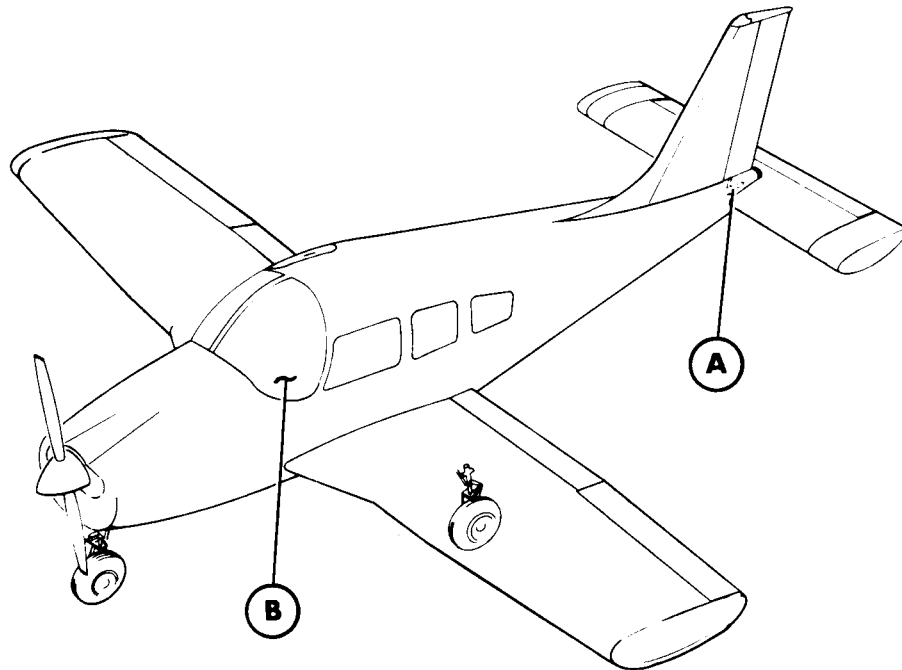

SKETCH A

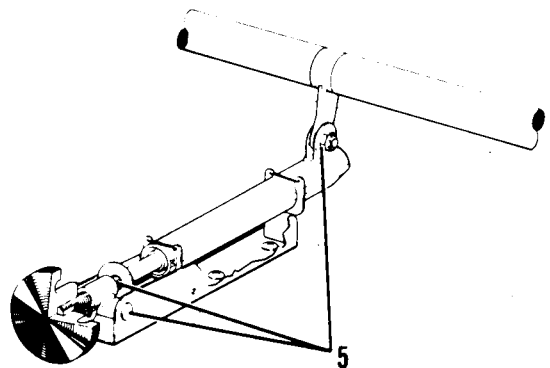

SKETCH B

Figure 2-18. Lubrication Chart (Control System) (cont.)

***CHEROKEE ARROW III SERVICE MANUAL**

COMPONENT	LUBRICANT	FREQUENCY
1. DOOR HINGES	MIL-L-7870	100 HRS
2. DOOR SEALS	MIL-L-60326	50 HRS
3. DOOR LATCH MECHANISMS	AERO LUBRIPLATE OR MAG-1 FISKE BROS. REFINING CO.	500 HRS
4. SEAT TRACK ROLLERS, STOP PINS AND REAR SEAT LEG RETAINER (CLIP AND CAM)	AERO LUBRIPLATE OR MAG-1 FISKE BROS. REFINING CO.	100 HRS
5. SEAT LATCH STOP PIVOT POINT (COPIIPT)	MIL-L-7870	100 HRS

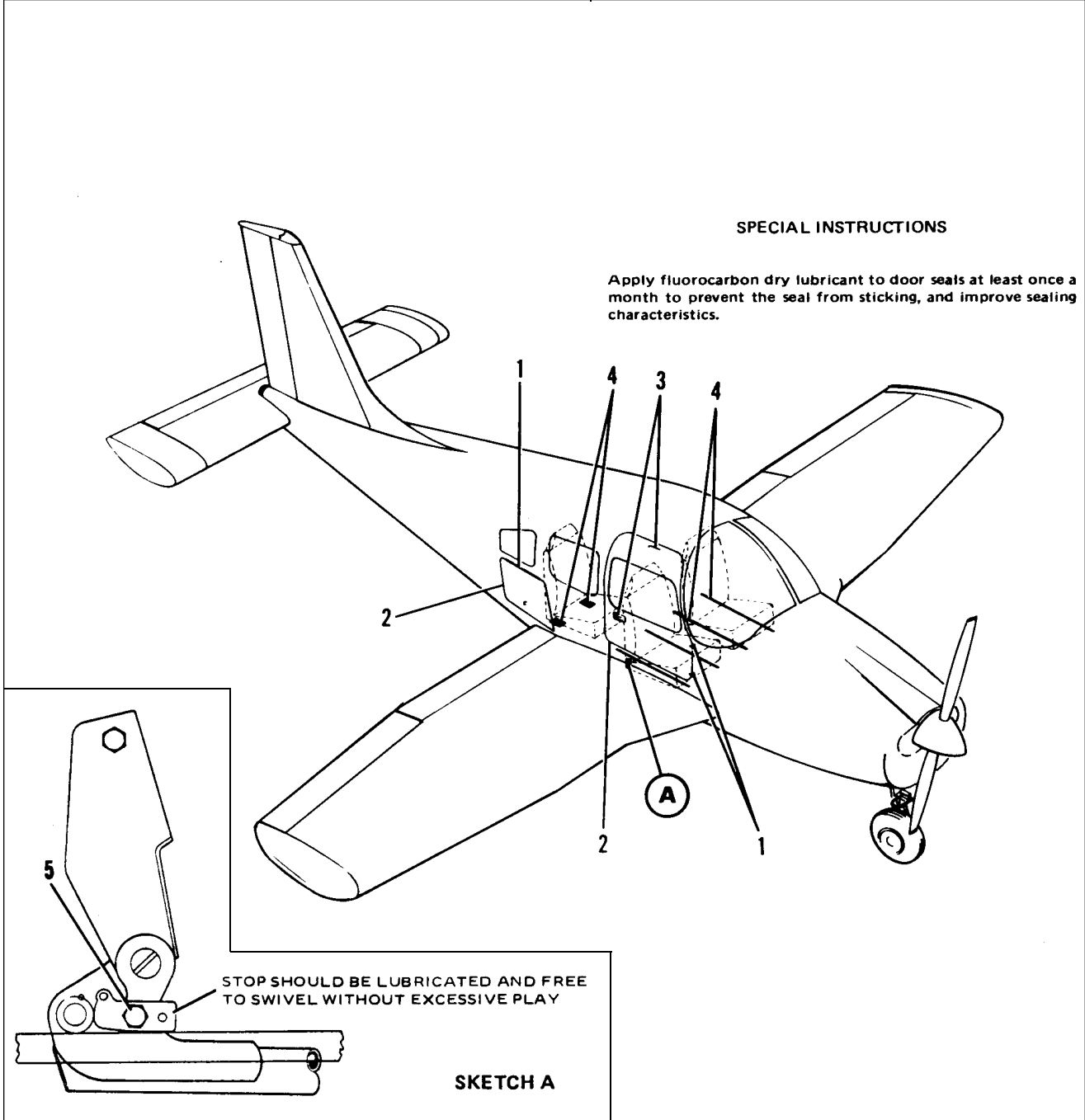
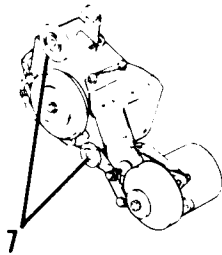

Figure 2-19. Lubrication Chart (Cabin Door, Baggage Door and Seat)

***CHEROKEE ARROW III SERVICE MANUAL**

COMPONENT	LUBRICANT	FREQUENCY
1. ENGINE SUMP (LYCOMING) PA-28 4-201 ONLY	MIL-L-6082 LUBRICATING OIL, AIRCRAFT RECIPROCATING ENGINE (PISTON) GRADE AS SPECIFIED, SAE 50 ABOVE 60°F AIR TEMP., SAE 40 30° TO 90°F AIR TEMP., SAE 30 20° TO 70°F AIR TEMP., SAE 20 BELOW 10°F AIR TEMP.	100 HRS
2. CARTRIDGE TYPE OIL FILTERS		50 HRS
3. AIR FILTERS	CLEAN AS OFTEN AS NECESSARY, EVERYDAY UNDER SEVERE CONDITIONS	
4. PROPELLER ASSEMBLY	MIL-G-23827	100 HRS
5. ENGINE CONTROL AND ENVIRONMENTAL CONTROL PIVOT POINTS	MIL-L-7870	100 HRS
6. FRESH AIR VENT SHAFTS	MIL-G-7711	500 HRS
7. ALTERNATOR AND COMPRESSOR IDLER PULLEY BEARINGS	MIL-G-81322	100 HRS



SKETCH B

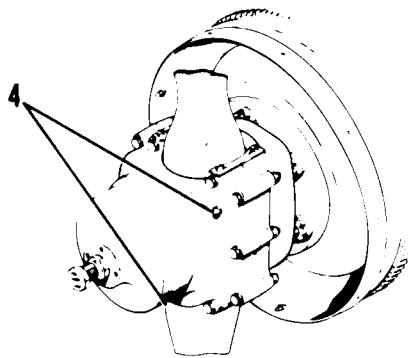
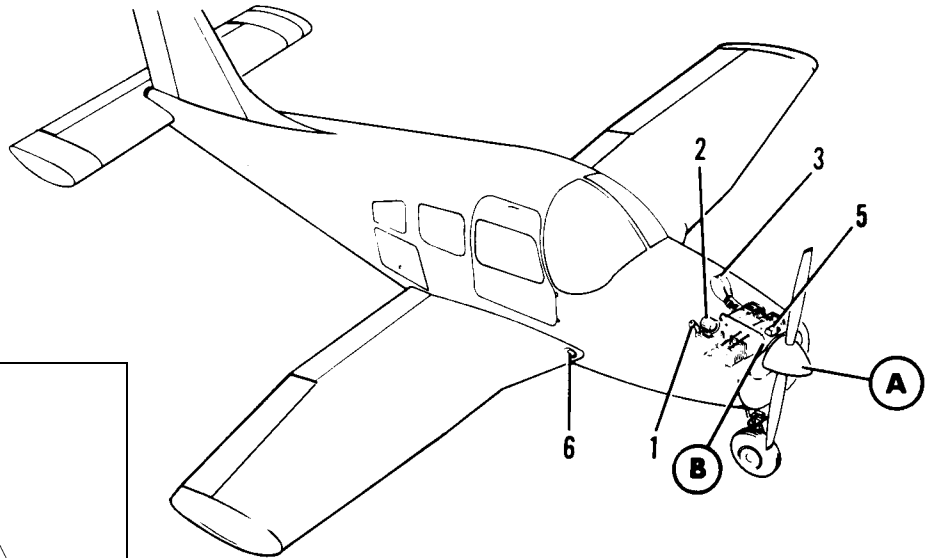

SKETCH A (HARTZELL PROPELLER)

SPECIAL INSTRUCTIONS

1. Air Filter - To clean filter, tap gently to remove dirt particles. Do not blow out with compressed air or use oil. Replace filter if punctured or damaged. Air filter is located on left side of engine cowl.
2. Propeller - Remove one of the two grease fittings for each blade. Apply grease through fitting until fresh grease appears at hole of removed fitting.

NOTE

See the latest revision of Lycoming Service Instructions No. 1014 for use of detergent oil.

Figure 2-20. Lubrication Chart (Lycoming Power Plant, Propeller and Control Pivot Points)

***CHEROKEE ARROW III SERVICE MANUAL**

COMPONENT	LUBRICANT	FREQUENCY
1. ENGINE OIL SUMPS (CONTINENTAL) PA-284-201T ONLY	CONTINENTAL SPECIFICATION MHS-24A AND SERVICE BULLETIN M75-2	100 HRS
2. OIL FILTER		50 HRS
3. INDUCTION AIR FILTERS	CLEAN AS OFTEN AS NECESSARY, EVERYDAY UNDER SEVERE CONDITIONS	
4. ALTERNATE AIR DOOR	MIL-L-7870	100 HRS
5. PROPELLER ASSEMBLY	MIL-G-23827	100 HRS
6. ENGINE CONTROL AND ENVIRONMENTAL CONTROL PIVOT POINTS	MIL-L-7870	100 HRS
7. FRESH AIR VENT SHAFTS	MIL-G-7711	500 HRS

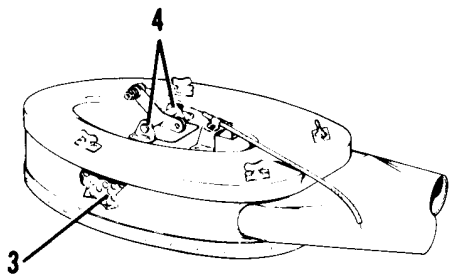

SKETCH B

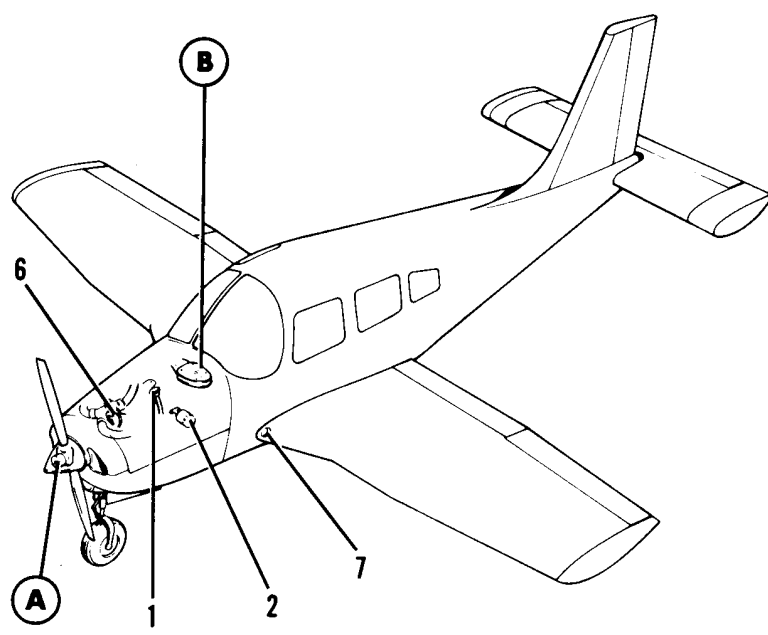

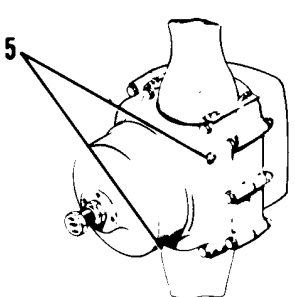

SKETCH A

SPECIAL INSTRUCTIONS

1. Air filter - To clean filter, tap gently to remove dirt particles. Do not blow out with compressed air or use oil; replace filter if punctured or damaged.
2. See TCM Service Bulletin M75-2 for recommended oil and filter change period. The engine lubricating oil system is serviced with MIL-C-6529, Type II for the initial fill and for the first 25 hours engine time per TCM Operator's Manual and MHS-184. Service engine thereafter with oil per MHS-24A and TCM Service Bulletin M75-2.
3. Ascertain that oil filter complies with specifications of TCM Service Bulletin M75-7.
4. Propeller - Remove one of two grease fittings for each blade. Apply grease through fitting until fresh grease appears at hole of removed fitting.

Figure 2-21. Lubrication Chart (Continental Power Plant, Propeller and Control Pivot Points)

***CHEROKEE ARROW III SERVICE MANUAL**

COMPONENT	LUBRICANT	FREQUENCY
1. DIAPHRAGM SHAFT AND BUSHING	MIL-L-7870 ABOVE 20°F MIL-C-21567 BELOW 20°F	100 HRS.
2. BACK-UP EXTENDER LNKS AND CONTROL ARM PIVOT POINTS	MIL-L-7870	100 HRS
3. BACK-UP EXTENDER SPRING ATTACHMENT POINTS	MIL-L-7870	100 HRS
4. ACTUATING ROD CONTACT POINTS	AERO LUBRIPLATE OR MAG-1	100 HRS\

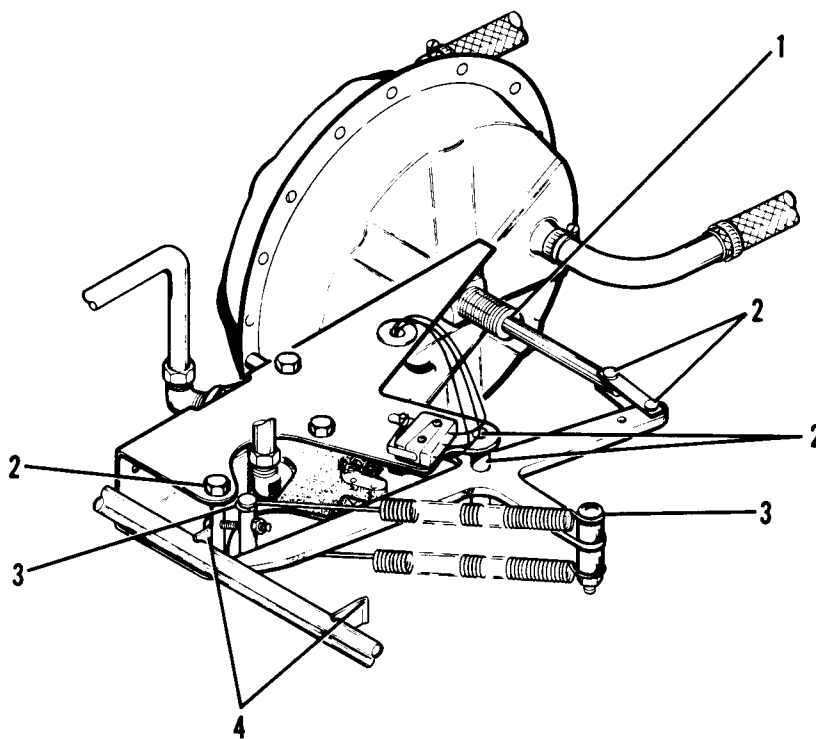

SPECIAL INSTRUCTIONS

1. Diaphragm shaft and bushing - soft film silicon compound (MIL-C-21567) is recommended for use when operating at temperatures below 20° F.
2. Fuel selector valve - Lubricate area where detent ball moves across cover plate (on external detent valves only).

Figure 2-22. Lubrication Chart (Back-Up Extender)

***CHEROKEE ARROW III SERVICE MANUAL**

COMPONENT	LUBRICANT	FREQUENCY
1. CONDENSER HINGE AND ACTUATORS	MIL-L-7870	100 HRS
2. CONDENSER DOOR ACTUATING TRANSMISSION	MIL-G-23827	500 HRS

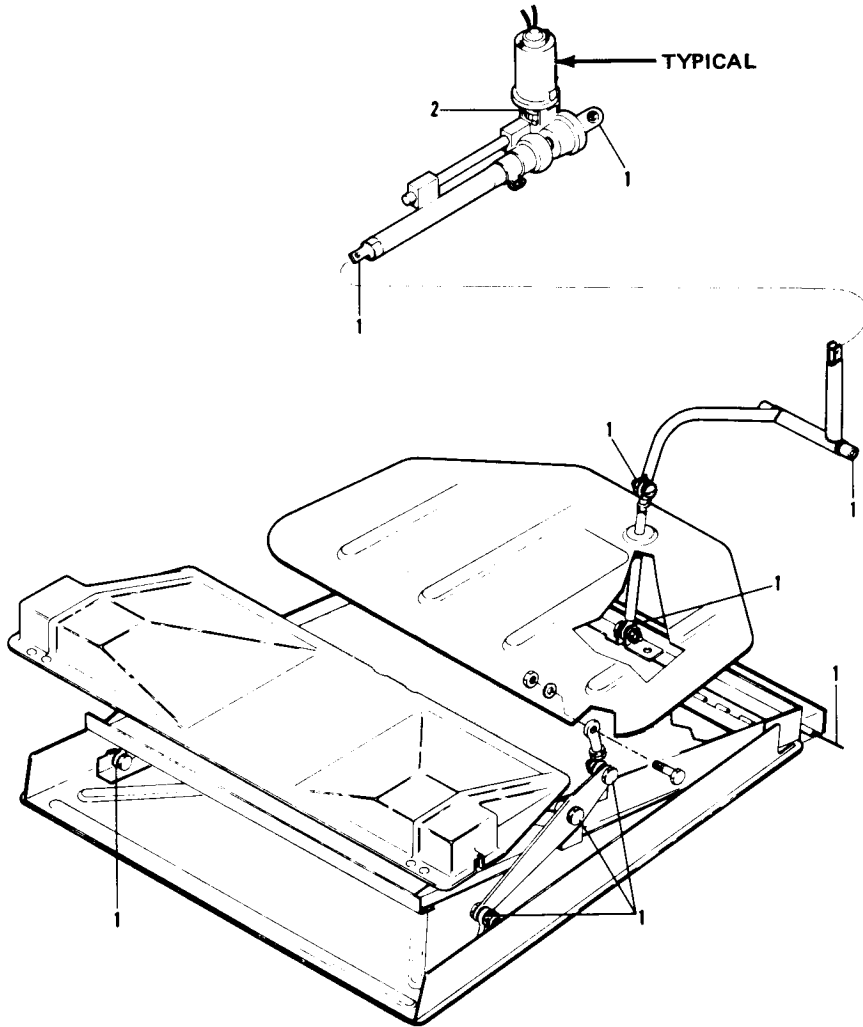

SPECIAL INSTRUCTIONS

Transmission to be 1/2 full of grease. Apply grease during assembly and lubricate transmission ball nut and screw with MIL-G-23827 grease.

Figure 2-23. Lubrication Chart (Air Conditioning Condenser)

***SECTION III**

INSPECTION

Paragraph		Aerofiche Grid No.
3-1.	Introduction	1D2
3-2.	Recommended Lubrication.	1D2
3-3.	Inspection Periods	1D2
3-4.	Inspection Requirements.	1D2
3-5.	Preflight Inspection	1D3
3-6.	Overlimits Inspection	1D3
3-7.	Special Inspection.....	1D3
3-8.	Service Publication Compliance Requirements.	1D3
	Table III-I Inspection Report.....	1D4

SECTION III

INSPECTION

3-1. INTRODUCTION. This section provides instructions for conducting inspections. These inspections are described in Paragraphs 3-4 and 3-5. Repair or replacement instructions for those components found to be unserviceable at inspection may be found in the section covering the applicable aircraft system.

CAUTION

When working on engines, ground the magneto primary circuit before performing any operation.

3-2. RECOMMENDED LUBRICANTS. Refer to Recommended Lubricants, Section II for Lubrication Servicing Instructions.

3-3. INSPECTION PERIODS.

3-4. INSPECTION REQUIREMENTS. Required inspection procedures are listed in Table III-I. The inspection procedure is broken down into eight major groups which are Propeller, Engine, Cabin, Fuselage and Empennage, Wing, Landing Gear, Operational Inspection and General. The first column in each group lists the inspection or procedure to be performed. The second column is divided into four columns indicating the required inspection intervals of 50 hours, 100 hours, 500 hours, and 1000 hours. Each inspection of operation is required at each of the inspection intervals as indicated by a circle (O). If an item is not entirely accessible or must be removed, refer to the applicable section of this manual for instructions on how to gain access to remove the item. When performing inspections, use the annual inspection form furnished by the Piper Service Department, available through Piper Dealers or Distributors.

3-5. **PREFLIGHT INSPECTION.** This inspection is for the pilot/or mechanic and should become part of the airplane operational routine and/or preflight inspection before each flight.

- a. The propeller blade is free of nicks and the spinner and hub free of cracks or damage.
- b. The engine oil is at the proper level.
- c. There are no obvious oil leaks.
- d. The cowling is clean. There are no loose or missing fasteners and all inspection covers are secured.
- e. There are no foreign objects in the engine compartment or obstructions in the air intakes, and cylinder baffle seals on left and right side are properly positioned. Seals should be rolled up against inner surface of upper cowl.
- f. The tires are properly inflated and not excessively worn or cut.
- g. The landing gear oleo struts have proper extension.
- h. The brakes are working and there are no obvious leaks.
- i. The fuel tanks are full or at a safe level of proper fuel.
- j. There are no visible leaks in the fuel system.
- k. The fuel tank caps are secure and the vents are open.
- l. The fuel tanks and sediment bowls, strainers and lines are free of water and sediment by draining sumps and strainers.
- m. There is no external damage, cracks or operational interference to the control surfaces, wings or fuselage.
- n. The windshield and windows are free of defects and clean.
- o. The baggage door latch, hinges, and cabin entrance door and window are free of damage and operate properly.
- p. The seats and seat belts are securely fastened.
- q. The landing, navigation, and cabin instrument lights are all operating.
- r. The fuel selector valve is operating properly.
- s. The throttle, mixture and propeller controls are all operating properly.
- t. All systems are operating properly.

3-6. **OVERLIMIT INSPECTION.** If the airplane has been operated so that any of its components have exceeded their maximum operational limits, check with the appropriate manufacturer.

3-7. **SPECIAL INSPECTIONS.** The special inspections given in the following paragraphs, supplement the scheduled inspections as outlined in the Inspection Report, Table III-I, to include inspection of items which are required to be examined at intervals not compatible with airframe operating time or airframe inspection intervals. Typical of this type are:

- a. Inspection required because of special conditions or incidents that arise, and because of these conditions or incidents, an immediate inspection would be required to ensure further safe flight.
- b. Inspection of airframe or components on a calendar basis. This type of inspection could often be accomplished during the nearest scheduled inspection.
- c. Specific definitive inspection on engines based strictly upon engine operating time.
- d. Those inspections not completely covered in other sections of this manual, but outlined in the Inspection Report and must be explained in more detail to give a clearer and complete inspection.

3-8. **SERVICE PUBLICATION COMPLIANCE REQUIREMENTS.** Piper Service Publications are recommended and/or mandatory changes to Piper aircraft. "Piper Service Bulletins are of Special Importance and Piper considers compliance mandatory".

CHEROKEE ARROW III SERVICE MANUAL

TABLE III-I INSPECTION REPORT.

—Note—

Perform all inspections or operations at each of the inspection intervals as indicated by a circle (O). (See Notes at end of report)

Nature of Inspection	Inspection Time (Hrs)			
	50	100	500	1000
A. PROPELLER GROUP				
WARNING				
<i>Read Note 28 prior to completing this inspection group.</i>				
1. Inspect spinner and back plate for cracks.....	O	O	O	O
2. Inspect blades for nicks and cracks.....	O	O	O	O
3. Inspect for grease and oil leaks.....	O	O	O	O
4. Lubricate propeller per lubrication chart (Refer to Service Manual, Section II).....	O	O	O	O
5. Inspect complete spinner and spinner mounting bulkheads, for security, chafing, cracks, deterioration, wear, and correct installation.....		O	O	O
6. Inspect propeller mounting bolts and safety (check torque if safety is broken) (Refer to Note 16).....		O	O	O
7. Inspect hub parts for cracks and corrosion		O	O	O
8. Rotate blades of propeller and check for tightness in hub pilot tube.....		O	O	O
9. Remove propeller and clean sludge from propeller and shaft.....			O	O
10. Inspect complete propeller assembly for security, chafing, deterioration, wear, and correct installation.....		O	O	O
11. Overhaul propeller per manufacturers recommendations (See Notes 5 and 28).....				
B. ENGINE GROUP (CONTINENTAL)				
WARNING				
<i>Read Notes 22, 4, and 28 before completing this inspection group. When working on engine, ensure that magneto primary circuits are grounded.</i>				
1. Remove the engine cowling.....	O	O	O	O
2. Clean and inspect cowling for cracks, distortion and loose or missing fasteners.....		O	O	O
3. Drain oil sump while engine is still warm.....		O	O	O
4. Change full flow (spin-on type) oil filter element. Thoroughly inspect element for foreign particles). Check oil level after installing new filter. (Another check will be required after engine runup)	O	O	O	O
5. Inspect oil temperature sender unit for leaks and security.....	O	O	O	O
6. Inspect oil lines, hoses, and fittings for leaks, security, chafing, dents and cracks (Read Note 6).....	O	O	O	O

CHEROKEE ARROW III SERVICE MANUAL

TABLE III-I INSPECTION REPORT (cont)

Nature of Inspection	Inspection Time (HRS)			
	50	100	500	1000
B. ENGINE GROUP (CONTINENTAL) (Cont.)				
7. Clean and inspect oil radiator cooling fins. Verify that there is no radiator damage.....		O	O	O
8. Fill engine oil sump with oil per approved information cowl, or lubrication chart. (Refer to Service Manual Section II.....		O	O	O
-CAUTION-				
<i>DO NOT USE MULTIGRADE OIL until Hartzell Service Bulletin 142B has been complied with.</i>				
-CAUTION-				
<i>Prior to cleaning engine, use caution not to contaminate vacuum pump with cleaning fluid. Cap all openings.</i>				
9. Clean engine, then (Read Note 29).....	O	O	O	O
10. Inspect condition of spark plugs. (Clean and adjust gap as required) (Read Note 8).....		O	O	O
11. Check cylinder compression, preferably with engine warm. (Read Note 12).....				
12. Inspect ignition harness and insulators (high tension leakage and continuity) (Read Notes 5 and 21)		O	O	O
13. Check magneto points for proper clearance (maintain clearance of 0.018 +/- 0.006 inch). (Read Note 5)		O	O	O
14. Inspect magneto or oil seal leakage.....		O	O	O
15. Inspect breaker felts for proper lubrication.....		O	O	O
16. Inspect distributor block for cracks, burned areas, or corrosion, and height of contact springs			O	O
17. Check magneto-to-engine timing (Read Note 15).....		O	O	O
18. Overhaul or replace magnetos (Read Note 5).....				O
19. Remove induction air filter and tap gently to remove all foreign particles (replace as required).....	O	O	O	O
20. Clean injector nozzles (Clean with acetone only)	O	O	O	O
21. Inspect induction airbox valve operation and check for excessive wear or..... cracks; replace defective parts.....		O	O	O
22. Inspect fuel injector attachments for loose hardware		O	O	O
23. Inspect intake seals for leaks and clamps for tightness (Read Note 24).....		O	O	O
24. Inspect all air inlet duct hoses (Replace as required).....		O	O	O
25. Inspect condition of flexible fuel lines. (Replace all outdated or deteriorated hoses).....		O	O	O
26. Replace flexible fuel lines (Read Note 6).....				O
27. Clean gascolator bowl and screen.....	O	O	O	O
28. Inspect fuel system for leaks		O	O	O

CHEROKEE ARROW III SERVICE MANUAL

TABLE III-I INSPECTION REPORT (cont)

Nature of Inspection	Inspection Time (HRS)			
	50	100	500	1000
B. ENGINE GROUP (CONTINENTAL) (cont.)				
29. Inspect condition and operation of fuel pumps (engine driven and electric)		O	O	O
30. Overhaul or replace engine-driven fuel pumps per manufacturer's recommendations (Read Note 5)				
31. Overhaul or replace electric fuel pump as required				O
32. Inspect hoses, wires, clamps, condition, and operation of vacuum pump(s) (engine-driven and auxiliary electrically-driven) (Read Note 25)		O	O	O
33. Replace engine or electrically driven vacuum pump(s) (Read Note(s) 5 and 25)....				O
34. Inspect throttle, alternate air, mixture, and propeller controls for security, travel, and operating condition		O	O	O
35. Inspect exhaust stacks, connections, and gaskets (Replace gaskets as required)	O	O	O	O
36. Inspect breather tubes for obstructions and security.....		O	O	O
37. Inspect crankcase for cracks, leaks, and security of seam bolts.....		O	O	O
38. Inspect engine mounts for cracks and loose		O	O	O
39. Inspect rubber engine mount bushings for deterioration (replace as reqd.) or at engine overhaul		O	O	O
40. Inspect all engine baffles and seals.....		O	O	O
41. Inspect fire wall seals.....		O	O	O
42. Inspect condition of alternator and starter		O	O	O
43. Inspect all lines, hoses, air ducts, electrical leads, and engine attachments for security, proper routing, chafing, cracks, deterioration and correct installation (Refer to latest Piper Service Bulletin 561).....	O	O	O	O
44. Check air conditioner compressor oil level (Read Note 13).....		O	O	O
45. Inspect condition and tension of compressor drive belt (Refer to Service Manual, Section XIV)		O	O	O
46. Inspect security of compressor mounting.....		O	O	O
47. Inspect compressor clutch security, wiring, and condition.....		O	O	O
48. Check fluid in brake reservoir (Fill as required)	O	O	O	O
49. Overhaul or replace propeller governor per manufacturer's recommendations. (Refer to latest revision of Hartzell Letter 61).....				

CHEROKEE ARROW III SERVICE MANUAL

TABLE III-I INSPECTION REPORT (cont)

Nature of Inspection	Inspection Time (Hrs)			
	50	100	500	1000
B. ENGINE GROUP (CONTINENTAL) (Cont.)				
50. Complete overhaul of engine or replace with factory rebuilt. (Read Note 5)				
C. TURBOCHARGER GROUP (CONTINENTAL)				
-WARNING-				
<i>Read Note 24 and 28 prior to completing this inspection group. Refer to latest revision of Service Bulletin 844.</i>				
1. Inspect all oil inlet ducting and compressor discharge ducting for worn spots, loose clamps, or leaks. (Read Note 24)	O	O	O	O
2. Inspect engine air inlet assembly for cracks, loose clamps, and screws.	O	O	O	O
3. Inspect exhaust ducting and exhaust stacks for tightness (Read Note 24).....	O	O	O	O
4. Inspect exhaust heat exchanger.....		O	O	O
5. Carefully inspect all turbo support brackets, struts, etc., for damage, sagging, and wear.....	O	O	O	O
6. Inspect all oil hoses, lines, and fittings for wear, leakage, heat damage, and fatigue.....	O	O	O	O
7. Inspect bypass valve for security and safety.....	O	O	O	O
8. Run up engine, and check all instruments for smooth, steady response.....	O	O	O	O
9. Remove all turbocharger components from the engine. Inspect and repair or replace as necessary. Inspect turbocharger rotor for excessive play, carbon and dirt deposits. (Refer to Troubleshooting Chart Section VIII of the Service Manual for rotor play limits.) Remove and inspect turbine and compressor housings. Refer to Rotor master A. D. Inspect turbine wheel and impeller for physical damage and excessive build up of deposits. If excessive, replace turbocharger assembly.....				O
D. ENGINE GROUP (LYCOMING)				
-WARNING-				
<i>Read Note 3 and 28 before completing this inspection group. When working on engine, ensure that magneto primary circuits are grounded.</i>				
1. Remove engine cowl and inspect for damage	O	O	O	O
2. Clean and inspect cowling for cracks, distortion, and loose or missing fasteners. (See Note 32).....		O	O	O
3. Drain oil sump while engine is still warm		O	O	O

CHEROKEE ARROW III SERVICE MANUAL

TABLE III-I. INSPECTION REPORT (cont)

Nature of Inspection	Inspection Time (HRS)			
	50	100	500	1000
D. ENGINE GROUP (LYCOMING)				
4. Clean oil suction and oil pressure strainers at oil change (Inspect strainers for foreign particles).....		O	O	O
5. Change full flow (cartridge type) oil filter element (inspect element thoroughly for foreign particles.....	O	O	O	O
6. Inspect oil temperature sender unit for leaks and security.....		O	O	O
7. Inspect oil lines, hoses, and fittings for leaks, security, chafing, dents, and cracks (Read Note 6)	O	O	O	O
8. Clean and inspect oil radiator cooling fins. Verify that there is no radiator damage.....		O	O	O
9. Remove and flush oil radiator.....		O	O	O
10.Fill engine with oil per lubrication chart in Service Manual, Section II.....		O	O	O
<p>CAUTION <i>Prior to cleaning engine, use caution not to contaminate vacuum pump(s) with cleaning fluid Cap all openings. (Refer to latest revision of Lycoming Service Instruction 1221).</i></p>				
11.Clean engine		O	O	O
12.Inspect condition of spark plugs (clean and adjust as required. (Refer to latest revision of Lycoming Service Instruction 1042.....		O	O	O
<p>NOTE <i>If fouling of spark plugs are apparent, rotate bottom plugs to upper plugs, and visa versa.</i></p>				
13.Inspect spark plug harness leads and ceramics for corrosion and deposits.....	O	O	O	O
14.Check cylinder compression (Refer to latest revision of Lycoming Service Instruction 1042).....		O	O	O
15.Inspect cylinders for cracked or broken fins (Read Note 10).....		O	O	O
16.Inspect rocker box covers for evidence of oil leaks. If found, replace gasket(s); Torque cover screws 50 inch-pounds (Read Note 9)	O	O	O	O
<p>NOTE <i>Lycoming requires a valve inspection after every 400 hours of engine operation. (Read Note 9)</i></p>				

CHEROKEE ARROW III SERVICE MANUAL

TABLE III-I. INSPECTION REPORT (cont)

Nature of Inspection	Inspection Time (HRS)			
	50	100	500	1000
D, ENGINE GROUP (LYCOMING) (cont.)				
17. Inspect ignition harness and insulators (High tension leakage and continuity tests).....		0	0	0
18. Inspect magneto points for condition and proper clearance. (Read Note 28) (Refer to Service Manual, Section VIIIA)		0	0	0
19. Inspect magneto seals for oil leaks.....		0	0	0
20. Inspect breaker felts for proper lubrication.....		0	0	0
21. Inspect distributor block for cracks, burned areas, or corrosion and height of contact springs.....			0	0
22. Check magnetos to engine timing.....		0	0	0
23. Overhaul or replace magnetos (Read Note 5).....				0
24. Remove air filter and tap gently to remove foreign dirt particles (Replace if required)	0	0	0	0
25. Clean fuel injector inlet line screen. Clean injector nozzles as required using acetone only	0	0	0	0
26. Inspect condition of injector, alternate air door and box (Read Note 7)	0	0	0	0
27. Inspect vent lines for evidence of fuel or oil seepage.....	0	0	0	0
28. Inspect intake seals for leaks and for tight clamps.....	0	0	0	0
29. Inspect all air inlet duct hoses (Replace as required).....	0	0	0	0
30. Inspect condition of flexible fuel lines (Replace all outdated or deteriorated hoses) ..		0	0	0
31. Replace flexible fuel lines (Read Note 5)				0
32. Clean gascolator bowl and screens.....	0	0	0	0
33. Inspect fuel system for leaks	0	0	0	0
34. Inspect condition and operation of fuel pump(s) (engine driven and electric)		0	0	0
35. Overhaul or replace fuel pump(s) per manufacturer's recommendation (engine driven and electric) (Read Note(s) 5 and 28).....				
36. Inspect hoses, wire harness, clamps, and condition and operation of vacuum pump(s) (engine driven and auxiliary electric).....		0	0	0
37. Overhaul or replace engine or auxiliary vacuum pump assemblies. (Read Note 5, 25, and 28).....				0
38. Inspect throttle, alternate air, mixture, propeller, and governor controls for security, travel, and operating condition		0	0	0
39. Inspect exhaust stacks, connections, and gaskets (Replace gaskets as required).....		0	0	0
40. Inspect muffler system, heat exchange, and baffles (Refer to latest revision of Piper Service Bulletin 691).....		0	0	0
41. Inspect breather lube for obstructions and security		0	0	0
42. Inspect crankcase for cracks, leaks, and security of seam bolts		0	0	0
43. Inspect engine mounts for cracks and loose mountings		0	0	0
44. Inspect all engine baffles		0	0	0
45. Inspect all wiring connected to engine or accessories		0	0	0
46. Inspect rubber engine mount bushings for deterioration. (Replace as required) or at engine overhaul		0	0	0
47. Inspect firewall seals.....		0	0	0

CHEROKEE ARROW III SERVICE MANUAL

TABLE III-I INSPECTION REPORT (cont)

Nature of Inspection	Inspection Time (Hrs)			
	50	100	500	1000
D. ENGINE GROUP (LYCOMING) (cont.)				
48. Inspect condition and tension of alternator drive belt (Refer to Service Manual, Section XI; XIV, if air conditioner is installed)		O	O	O
49. Inspect alternator idler pulley (if installed); remove front grease seal and add grease. Refer to lubrication chart in Service Manual, Section II		O	O	O
50. Inspect condition of alternator and starter		O	O	O
51. Inspect security of alternator mounting		O	O	O
52. Check air conditioner compressor oil level (Read Note 13).....		O	O	O
53. Inspect condition of compressor belt and tension (Refer to Service Manual, Section XIV).....		O	O	O
54. Inspect compressor clutch security and wiring		O	O	O
55. Inspect security of compressor mounting.....		O	O	O
56. Check fluid in brake reservoir (Fill as required)	O	O	O	O
57. Lubricate all controls per lubrication chart in Service Manual, Section II.....		O	O	O
58. Overhaul or replace propeller governor per manufacturer's recommendations (Read Note(s) 5 and 28).....		O	O	O
59. Complete overhaul of engine or replace with factory rebuilt (Read Note(s) 5 and 28)		O	O	O
60. Install the engine cowl.....	O	O	O	O
E. CABIN GROUP				
WARNING				
<i>Read Note 28 before completing this inspection group.</i>				
1. Inspect cabin entrance door and windows for damage, operation, and security	O	O	O	O
2. Inspect seats, seat belts, shoulder harness, security brackets and bolts (Read Note 26)		O	O	O
3. Inspect trim operation.....		O	O	O
4. Inspect rudder pedals.....		O	O	O
5. Inspect parking brake and brake handle for operation and cylinder leaks.....		O	O	O
6. Inspect control wheels, column, pulleys, chain, and cables (Read Note 23).....		O	O	O
7. Inspect flap control cable attachment bolt (See latest revision of Piper Service Bulletin 965).....		O	O	O
8. Check landing, navigation, cabin, and instrument lights.....	O	O	O	O
9. Inspect instruments, lines, and attachments		O	O	O
10. Inspect gyro-operated instruments and electric turn and bank (Overhaul or replace as required).....		O	O	O
11. Replace instrument central air filter.....		O	O	O
12. Inspect or replace vacuum regulator filter.....		O	O	O
13. Check altimeter (Calibrate altimeter system in accordance with FAR 91.170, if appropriate) (Read Note 11).....		O	O	O

CHEROKEE ARROW III SERVICE MANUAL

TABLE III-I. INSPECTION REPORT (cont)

Nature of Inspection	Inspection Time (Hrs)			
	50	100	500	1000
E. CABIN GROUP (cont.)				
15. Inspect operation of fuel selector valve.....		O	O	O
16. Inspect condition of heater controls and ducts.....		O	O	O
17. Inspect condition and operation of air vents.....		O	O	O
18. Inspect condition of air conditioner ducts.....		O	O	O
19. Remove and clean air conditioner evaporator filter.....		O	O	O
F. FUSELAGE AND EMPENNAGE GROUP				
WARNING				
<i>Read Note 28 before completing this inspection group.</i>				
1. Remove inspection plates and panels (See Note 33).....		O	O	O
2. Inspect baggage door, latch, and hinges for condition operation, and security.....		O	O	O
3. Inspect battery, box, and cables for corrosion, damage, frayed cables, and loose terminals. (Service every 30 days) Refer to Service Manual or box instructions ...	O	O	O	O
4. Inspect all electronic components for security		O	O	O
5. Inspect bulkheads and stringers for damage.....		O	O	O
6. Inspect antenna mounts and electrical wiring for security and corrosion in plugs. .		O	O	O
7. Inspect hydraulic pump motor brushes (Read Note(s) 19 and 28).....		O	O	O
8. Check hydraulic pump fluid level (Service as required)	O	O	O	O
9. Inspect hydraulic pump lines and hoses for damage and leaks		O	O	O
10. Inspect for obstructions and contamination in inlet of backup landing gear extender actuator inlet head (if applicable) (Read Note 27).....	O	O	O	O
11. Inspect air conditioner system for Freon leaks		O	O	O
12. Check Freon charge in sight gauge of receiver-dehydrator (Refer to Service Manual, Section XIV).....	O	O	O	O
13. Inspect air conditioner condenser air scoop rigging.....	O	O	O	O
14. Inspect fuel lines, hoses, valves, sender units, and gauges for damage and operation .		O	O	O
15. Inspect security of all hoses and lines.....		O	O	O
16. Inspect vertical fin and rudder surfaces for damage.....		O	O	O
17. Inspect rudder hinges, horn, and attachments for damage and operation		O	O	O
18. Inspect vertical fin attachments		O	O	O
19. Inspect rudder hinge bolts for excess wear (Replace as required).....		O	O	O
20. Inspect rudder control stops to ensure stop has not become loose and jamb nut is tight.....		O	O	O
21. Inspect stabilator surfaces for damage.....		O	O	O
22. Inspect stabilator, tab hinges, horn, and attachments for damage and operation.....		O	O	O
23. Inspect stabilator attachments (Refer to latest revision of Piper Service Bulletin 856).....		O	O	O

CHEROKEE ARROW III SERVICE MANUAL

TABLE III-I. INSPECTION REPORT (cont)

Nature of Inspection	Inspection Time (Hrs)			
	50	100	500	1000
F. FUSELAGE GROUP (CONT.)				
24. Inspect stabilator and trim tab hinge bolts and bearings for excessive wear. (Replace as required).....		O	O	O
25. Inspect stabilator control stops to ensure stop has not become loose and that the jamb nut is tight.....		O	O	O
26. Inspect stabilator trim mechanism.....		O	O	O
27. Inspect fuselage wing attach fittings for corrosion, general condition and security. (See latest revision of Piper Service Bulletin 977.).....		O	O	O
28. Check all cable tensions (Use tensionmeter) (Read Note 17)		O	O	O
29. Inspect cables, aileron, rudder, stabilator, stabilator trim, turnbuckles, guides and pulleys for safety, damage, and operation (Read Notes 23 and 34)		O	O	O
30. Clean and lubricate stabilator trim drum screw (Refer to lubrication chart in Service Manual, Section II)		O	O	O
31. Inspect stabilator balance weight attachments and arm for security and condition .		O	O	O
32. Inspect emergency locator transmitter battery for replacement date per Service Manual (Read latest revision of Piper Service Letter 820).....		O	O	O
33. Clean and lubricate all exterior needle bearings		O	O	O
34. Lubricate per lubrication chart in Service Manual, Section II.....	O	O	O	O
35. Inspect rotating beacon for security and operation		O	O	O
36. Inspect security of autopilot bridle cable clamps (Read Note 23).....		O	O	O
37. Inspect all control cables, air ducts, electrical leads, harnesses, lines, radio antenna leads, and attaching parts for security, routing, chafing, deterioration, wear, and correct installation (Read Note 23).....		O	O	O
38. Install inspection plates and panels		O	O	O
G. WING GROUP				
WARNING				
<i>Read Note 28 before completing this inspection group.</i>				
1. Remove inspection plates and fairings		O	O	O
2. Inspect surfaces and tips for damage, loose rivets, and condition of wing walkway		O	O	O
3. Inspect aileron hinges and attachments		O	O	O
4. Inspect aileron balance weight and arm for security and condition		O	O	O
5. Inspect aileron cables, pulleys, and bellcranks for damage and operation (Read Note 23)		O	O	O
6. Inspect aileron control stops to ensure stops have not become loose and that locknuts are tight		O	O	O
7. Inspect flaps and attachments for damage and operation.....		O	O	O

CHEROKEE ARROW III SERVICE MANUAL

TABLE III-I. INSPECTION REPORT (cont)

Nature of Inspection	Inspection Time (Hrs)			
	50	100	500	1000
G. WING GROUP (cont.)				
8. Inspect condition of bolts used with hinges (Replace as required).....		O	O	O
9. Lubricate per lubrication chart in Service Manual Section II.....	O	O	O	O
10. Inspect forward and aft wing attach fittings for corrosion, general condition and security. (See latest revision of Piper Service Bulletin 977.).....		O	O	O
11. Inspect wing attachment bolts and brackets (Refer to Piper Service Bulletin(s) 789A and 886)		O	O	O
12. Inspect fuel tanks and lines for leaks, water, and contamination		O	O	O
13. Ensure that fuel tanks are marked for minimum octane rating.....		O	O	O
14. Inspect the fuel cell vents.....		O	O	O
15. Inspect all control cables, air ducts, electrical leads, hoses, lines, and attaching parts for security, routing, chafing, deterioration, wear, and correct installation .(Read Note 23).....		O	O	O
16. Install inspection plates and fairings		O	O	O
H. LANDING GEAR GROUP				
WARNING				
<i>Read Note 28 before completing this inspection group.</i>				
1. Inspect oleo struts for proper extension (Refer to Service Manual, Section VII) (Check all fluid and air levels as required).....	O	O	O	O
2. Inspect nose gear steering control and travel		O	O	O
3. Inspect wheels for alignment.....		O	O	O
4. Lift aircraft on jacks (Refer to Service Manual, Section II).....		O	O	O
5. Inspect tires for cuts, uneven or excessive wear, and slippage.....		O	O	O
6. Remove wheels; clean, inspect, and repack bearings.....		O	O	O
7. Inspect wheels for cracks, corrosion, and broken bolts.....		O	O	O
8. Check tire pressure (Refer to Service Manual, Section II).....	O	O	O	O
9. Inspect brake linings and discs	O	O	O	O
10. Inspect brake backing plates.....		O	O	O
11. Inspect brake and hydraulic lines for leaks, loose fittings, or cracks		O	O	O
12. Inspect shimmy dampner.....		O	O	O
13. Inspect gear forks for damage		O	O	O
14. Inspect oleo struts for fluid leaks and scoring		O	O	O
15. Inspect gear struts, attachments, torque links, retraction links, and bolts for condition and security		O	O	O
16. Inspect downlock for operation and adjustment .(Read Note 18)	O	O	O	O
17. Inspect torque link bolts and bushings (Rebush as require)			O	O
18. Inspect drag and side brace link bolts (Replace as required).....				O
19. Inspect gear doors and attachments		O	O	O
20. Check warning horn and light for operation.....		O	O	O

CHEROKEE ARROW III SERVICE MANUAL

TABLE III-I. INSPECTION REPORT (cont)

Nature of Inspection	Inspection Time (HRS)			
	50	100	500	1000
H. LANDING GEAR GROUP (cont.)				
21. Retract gear, check operation and inspect doors for clearance and operation		O	O	O
22. Inspect operation of back-up gear extender system (If not disabled) (Read Piper Service Bulletin 866.) (Read Note 27).....		O	O	O
23. Inspect actuating cylinders for leaks and security		O	O	O
24. Inspect all hydraulic lines, hoses, electrical leads, and attaching parts for security, routing, chafing, deterioration, wear, and correct installation. (Read latest revision of Piper Service Letter(s) 808 and 810).....		O	O	O
25. Inspect position indicator switch and electrical leads for security		O	O	O
26. Lubricate per lubrication chart in Service Manual, Section II.....	O	O	O	O
27. Ensure landing gear is down and locked; remove airplane from jacks		O	O	O
I. OPERATIONAL INSPECTION				
1. Check fuel pump and fuel tank selector.....	O	O	O	O
2. Check fuel quantity, pressure, and flow indications.....	O	O	O	O
3. Check oil pressure and temperature indications.....	O	O	O	O
4. Check alternator performance.....	O	O	O	O
5. Check manifold pressure indications.....	O	O	O	O
6. Check alternate air operation.....	O	O	O	O
7. Check parking brake operation.....	O	O	O	O
8. Check engine driven vacuum gauge indication.....	O	O	O	O
9. Check gyros for noise and roughness.....	O	O	O	O
10. Check cabin heater operation.....	O	O	O	O
11. Check magneto switches operation.....	O	O	O	O
12. Check each magneto RPM variation; drop etc	O	O	O	O
13. Check throttle and mixture operation	O	O	O	O
14. Check propeller operation and smoothness.....	O	O	O	O
15. Check propeller governor operation and reaction.....	O	O	O	O
16. Check engine idle operation	O	O	O	O
17. Check electronic equipment operation	O	O	O	O
18. Check automatic pitch trim, and manual/electric trim operation (Read Note 20)....	O	O	O	O
19. Check air conditioner compressor clutch operation	O	O	O	O
20. Check air conditioner condenser scoop operation.....	O	O	O	O
21. Check landing gear system (Read Note 14).....	O	O	O	O
22. After shutdown, check auxiliary electric driven vacuum gauge indication.....	O	O	O	O
J. GENERAL.				
1. Aircraft conforms to all FAA specifications.....	O	O	O	O
2. All FAA Airworthiness Directives complied with.....	O	O	O	O
3. All manufacturers service bulletins and letters complied with.....	O	O	O	O
4. Check for proper night manual.....	O	O	O	O
5. Aircraft papers in proper order	O	O	O	O

TABLE III-I. INSPECTION REPORT (cont)

NOTES:

1. Refer to last card of the Piper Price List - Aerofiche, for a checklist of current revision dates to Piper Inspection Reports and Manuals.
2. **Piper service bulletins are of special importance and Piper considers compliance mandatory.** Piper service letters are product improvements and service hints pertaining to servicing the airplane and should be given careful attention.
3. Inspections given for the Lycoming powerplant are based on the engine manufacturer's operator's manual (**Lycoming Part No. 60297-12**) for this airplane, dated August 1973. Any changes issued to the engine manufacturer's operator's manual after this date shall supersede or supplement the inspection outlined in this report.
4. Inspections given for the (**Continental Part No. X-30512**) for this airplane, dated June 1976. Any changes issued to the engine manufacturer's operator's manual after this date shall supersede or supplement the inspection outlined in this report.
5. Replace as required or at engine overhaul. (**Refer to latest revision of Hartzell Service Letter 61.**) For engine overhaul, refer to latest revision of one of the following: Lycoming Service Instructions No. 1009, for commended engine overhaul period, or **Continental Service Bulletin M86-6 Rev. 1**, for recommended engine overhaul period.
6. Replace flexible oil hoses at three calendar years or 1000 hours, whichever occurs first.
7. Check throttle body attaching screws for tightness; the correct torque for these screws is 40 to 50 inch pounds
8. Rotate spark plugs from upper to lower positions and vice-versa to lengthen plug service life.
9. At every 400 hours of engine operation, remove the rocker box covers and check for freedom of valve rockers when valves are closed. Look for evidence of abnormal wear or broken parts in the area of the valve tips, valve keepers, springs and spring seals. If any indications are found, the cylinder and all of its components must be removed (including the piston and connecting rod assembly) and inspected for further damage. Replace any parts that do not conform with limits shown in the latest revision of **Lycoming's Service Table of Limits No. SSP1776.**
10. Check cylinders for evidence of excessive heat which is indicated by burned paint on the cylinders. This condition is indicative of internal damage to cylinder(s) and, if found, its cause must be determined and corrected before the aircraft is returned to service. Heavy discoloration and appearance of seepage at the cylinder head barrel attachment area is usually due to emission of thread lubricant used during assembly of the barrel at the factory, or by slight gas leakage which stops after the cylinder has been in service for awhile. This condition is neither harmful nor detrimental to engine performance and operation. If it can be proven that leakage exceeds these conditions, the cylinder must be replaced.
11. If the altimeter is damaged, defective or inaccurate, work must be done by an FAA approved instrument repair facility only. A logbook entry must be made.
12. Refer to latest revision of **Continental Motors Service Bulletin M84-17.**
13. The compressor oil level should not be checked unless the system has been opened, or a Freon leak occurred which requires an addition of Freon to the system.
14. Aircraft must be blown to check the landing gear system in accordance with instructions outlined in Section VI, of the Service Manual. (**Refer to latest revision of Piper Service Bulletin 810.**)
15. For operation above 12,000 feet, more frequent ignition system maintenance is required. (**Refer to latest revision of Continental Service Bulletin M78-8.**)
16. On Continental installations check torque of mounting bolts.
17. Maintain cable tensions specified in Section V of this Service Manual.

CHEROKEE ARROW III SERVICE MANUAL

TABLE III-I. INSPECTION REPORT (cont)

18. **Refer to latest revision of Piper Service Bulletin 578.**
19. Inspect brushes every 100 hours if used for training or every 500 hours if used for normal service. (Refer to latest vendor service publications.)
20. Refer to flight manual supplement for preflight and flight check, for intended function in all modes.
21. **Refer to latest revision of Bendix Service Bulletin 612 for inspection of magneto and ignition harnesses.**
22. **Refer to latest revision Teledyne Continental Service Bulletin M86-11.**
23. Examine cables for broken strands by wiping the cable along the length of the cable. Visually check for damage. Replace all damaged cables. Refer to latest revision of Advisory Circular 43.13.
24. Piper Service Bulletin 884 compliance requires lock wiring of V-band couplings.
25. Latest models, S/N's 2837001 (PA-28R-201) and S/N's 2803001 (PA-28R-201T) are equipped with auxiliary electric backup vacuum systems that require replacement after 500 hours of operation time.
26. **Piper Service Bulletin 896 compliance requires installation and usage of shoulder harnesses.**
27. **Refer to latest revision of Piper Service Bulletin 866a.** Aircraft S/N's 2837001 (PA-28R-201) and up, and S/N's 2803001 (PA-28R-201T) and up, have no backup extender system in the landing gear system installed as standard equipment.
28. When servicing or inspecting vendor equipment installed in Piper aircraft, it is the user's responsibility to refer to the applicable vendor service publications.
29. Ensure after cleaning engine that all rod end bearings are lubricated with at least 3 drops of 100W motor oil.
30. All inspections or operations are required at each of the inspection intervals as indicated by an (O). Both the annual and 100 hour inspection are complete inspections of the airplane, identical in scope, while both 500 and 1000 hour inspections are extensions of the annual or 100 hour inspections, which require a more detailed examination of the airplane and overhaul or replacement of some major components. Inspections must be accomplished by persons authorized by the FAA.
31. **Refer to latest revision of Service Bulletin 856.**
32. Inspect Teflon bushing (lower to upper cowling attachment) for condition at each 100 hours. Replace bushing on condition, but no later than 500 hours time in service. Inspect pin for condition and replace as necessary.
33. If not already installed, add access panels per instructions in Section IV, Paragraph 4-55a. See latest revision of Piper Service Bulletin 977.
34. Special care should be taken to inspect stabilator control cables beneath aft baggage compartment floor. Add access panels per instructions in Section IV, Paragraph 4-55a, to ease this inspection.

SECTION IV

STRUCTURES

Paragraph	Aerofiche Grid No.
4-1. Introduction	1D19
4-2. Description	1D19
4-3. Wing Group	1D19
4-4. Wing Flap	1D20
4-5. Removal of Wing Tip	1D20
4-6. Installation of Wing Flap	1D20
4-7. Aileron	1D20
4-8. Removal of Aileron	1D20
4-9. Installation of Aileron	1D20
4-10. Wing Flap	1D20
4-11. Removal of Wing Flap	1D20
4-12. Installation of Wing Flap	1D24
4-13. Wing	1D24
4-14. Removal of Wing	1D24
4-15. Installation of Wing	1E1
4-16. Empennage Group	1E2
4-17. Stabilator	1E2
4-18. Removal of Stabilator	1E2
4-19. Installation of Stabilator	1E3
4-20. Stabilator Trim Tab	1E4
4-21. Removal of Stabilator Trim Tab	1E4
4-22. Installation of Stabilator Trim Tab	1E4
4-23. Rudder	1E4
4-24. Removal of Rudder	1E4
4-25. Installation of Rudder	1E4
4-26. Vertical Fin	1E7
4-27. Removal of Vertical Fin	1E7
4-28. Installation of Vertical Fin	1F7
4-29. Fuselage Assembly	1E7
4-30. Windshield	1E7
4-31. Removal of Windshield	1E7
4-32. Installation of Windshield	1E9
4-33. Side Windows	1E9
4-34. Removal of Side Windows	1E9
4-35. Installation of Side Windows	1E9

CHEROKEE ARROW III SERVICE MANUAL

Paragraph	Aerofiche Grid No.
4-36. Door (Entrance).....	1E10
4-37. Removal of Door.....	1E10
4-38. Installation of Door.....	1E10
4-39. Adjustment of Door.....	1E10
4-40. Removal of Door Latch Mechanism	1E10
4-41. Installation of Door Latch Mechanism.....	1E12
4-42. Adjustment of Door Latch Mechanism.....	1E12
4-43. Removal of Door Lock Assembly.....	1E12
4-44. Installation of Door Lock Assembly	1E12
4-45. Removal of Door Safety Latch.....	1E12
4-46. Installation of Door Safety Latch.....	1E12
4-47. Adjustment of Door Safety Latch.....	1E12
4-47a. Removal and Installation of Door Seal Snubbers.....	1E12
4-48. Baggage Door.....	1E13
4-49. Removal of Baggage Door.....	1E13
4-50. Installation of Baggage Door.....	1E13
4-51. Removal of Baggage Door Lock Assembly.....	1E13
4-52. Installation of Baggage Door Lock Assembly	1E13
4-53. Removal of Baggage Door Hinge	1E14
4-54. Installation of Baggage Door Hinge.....	1E14
4-55. Structural Repairs.....	1E14
4-55a. Baggage Compartment Inspection Hole and Cover Plate.....	1E15
4-56. Fiberglass Repairs.....	1E17
4-57. Fiberglass Touch-Up and Surface Repairs	1E17
4-58. Fiberglass Fracture and Patch Repairs.....	1E18
4-59. Thermoplastic Repairs.....	1E19
4-60. Safety Walk Repair.....	1E19
4-61. Surface Preparation	1E19
4-62. Product Listing for Liquid Safety Walk Compound.....	1E19
4-63. Application of Liquid Safety Walk Compound.....	1E19
4-64. Control Surface Balancing	1E20
4-65. Checking Control Surface Balance	1E20
4-66. Checking Control Surface Free Play.....	1E20
4-67. Balancing Equipment	1E22
4-68. Balancing Ailerons.....	1E22
4-69. Balancing Rudder.....	1E23
4-70. Balancing Stabilator	1F1
4-71. Removal of Cherrylock Rivets.....	1F3
4-72. Standards	1F5
4-73. Torque Wrenches.....	1F5

SECTION IV

STRUCTURES

4-1. INTRODUCTION. This section explains the removal and installation procedures for the structural surfaces of the airplane. For the removal, installation, and rigging and adjustment procedures of the controlling components of the various structural surfaces, refer to Section V.

NOTE

When torquing structural assemblies, standard torque values are to be used as found in Section II or FAA Advisory Circular 43.13-1A, unless otherwise stated in this section.

4-2. DESCRIPTION. The aircrafts are all metal semi-monocoque structure with overall lengths of 24 feet 8.16 inches for the PA-28R-201 and 25 feet for the PA-28R-201T. The fuselage is constructed of bulkheads, stringer and stiffeners, to which all of the outer skin is riveted. Windows include a single pane windshield and six side windows. All windows are single pane. A storm window is located in the forward lower section of the left window and can be opened inward when the latch is released. The cabin entrance door is located on the right side of the fuselage, above the wing, and is equipped with a safety latch on the top of the door, which can be operated from the inside or outside. A door provided for entrance to the baggage compartment is located just aft of the right wing with a key lock installed.

Each wing panel is an all metal, full cantilever semi-monocoque type construction with a removable wing tip. Installed in each wing ahead of the main spar is a metal fuel tank with a capacity of 38.5 U.S. gallons each or 77 U.S. gallons total. Attached to each wing is an aileron, flap and main landing gear. The wings are attached to each side of the fuselage by inserting the butt ends of the main spars into a spar box carry-through. The spar box is an integral part of the fuselage structure which provides, in effect, a continuous main spar with splices at each side of the fuselage. There are also fore and aft attachments at the front and rear spars.

The all metal empennage group is a full cantilever design consisting of a vertical stabilizer (fin), rudder and stabilator, all with removable tips. The stabilator has a trim tab attached that is controllable from the cockpit. The stabilator also incorporates one channel main spar that runs the full length of the stabilator and hinges to the aft bulkhead assembly of the fuselage. All exterior surfaces are coated with enamel or acrylic lacquer. As an option the airplane may be completely primed with zinc chromate.

4-3. WING GROUP.

NOTE

The major subassemblies of the wing may be removed individually or the wing may be removed as a unit. To remove a wing, a fuselage supporting cradle is required.

4-4. WING TIP.

4-5. REMOVAL OF WING TIP.

- a. Remove the screws holding the wing tip to the wing, being careful not to damage the wing or wing tip.
- b. Pull off the wing tip far enough to disconnect the position and strobe light wire assembly. The ground lead may be disconnected at the point of connection on the wing rib, and the positive lead may be disconnected at the wire terminal or unscrewed from the light assembly.
- c. Inspect the wing tip to ascertain that it is free of cracks, severe nicks and minor damage. If repair is required, refer to paragraph 4-56.

4-6. INSTALLATION OF WING TIP.

- a. Place the wing tip in a position that the navigation and strobe light leads may be connected. Connect the ground lead to the wing rib by use of a screw and nut, and the positive lead to the position light by connecting the wire terminals or screwing the connectors together. Insulate the wire terminals and be certain that the ground lead is free of dirt and film to insure a good connection.
- b. Insert the wing tip into position and install the screws around the tip. Use caution to refrain from damaging the wing tip or wing. Check operation of the lights.

4-7. AILERON.

4-8. REMOVAL OF AILERON. (Refer to Figure 4-1.)

- a. Disconnect the aileron control rod at the aileron attachment point by removing the nut, washers and bolt from the rod end bearing. To simplify installation note location of washers removed.
- b. Remove the attaching screws, with nuts, from the hinges at the leading edge of the aileron, and remove the aileron by lowering the inboard end and swinging it forward to allow the balance arm to clear the opening in the outboard rib.

4-9. INSTALLATION OF AILERON. (Refer to Figure 4-1.)

- a. Install the balance arm into the opening in the outboard rib by moving the inboard end of the aileron forward to allow the arm to be inserted through the opening. Move the aileron into place and install attaching screws and nuts. Ascertain that the aileron is free to move with no interference.
- b. Attach the aileron control rod with bolts, washers and nut, dividing the washers so that the aileron is free to rotate from stop to stop without the control rod binding or rubbing on the opening in the aft spar. Be certain that the rod end bearing has no side play when tightening the bolt and that the rod does not contact the side of the bracket.
- c. Actuate the aileron controls to insure freedom of movement.

4-10. WING FLAP.

4-11. REMOVAL OF WING FLAP. (Refer to Figure 4-1.)

- a. Extend the flaps to their fullest degree and remove the bolt and bushing from the rod end bearing by use of an angle or offset screwdriver.
- b. Remove the nuts, washers, bushing and hinge bolts that hold the flap to the wing assembly.
- c. Pull the flap straight back off the wing.

* CHEROKEE ARROW III SERVICE MANUAL

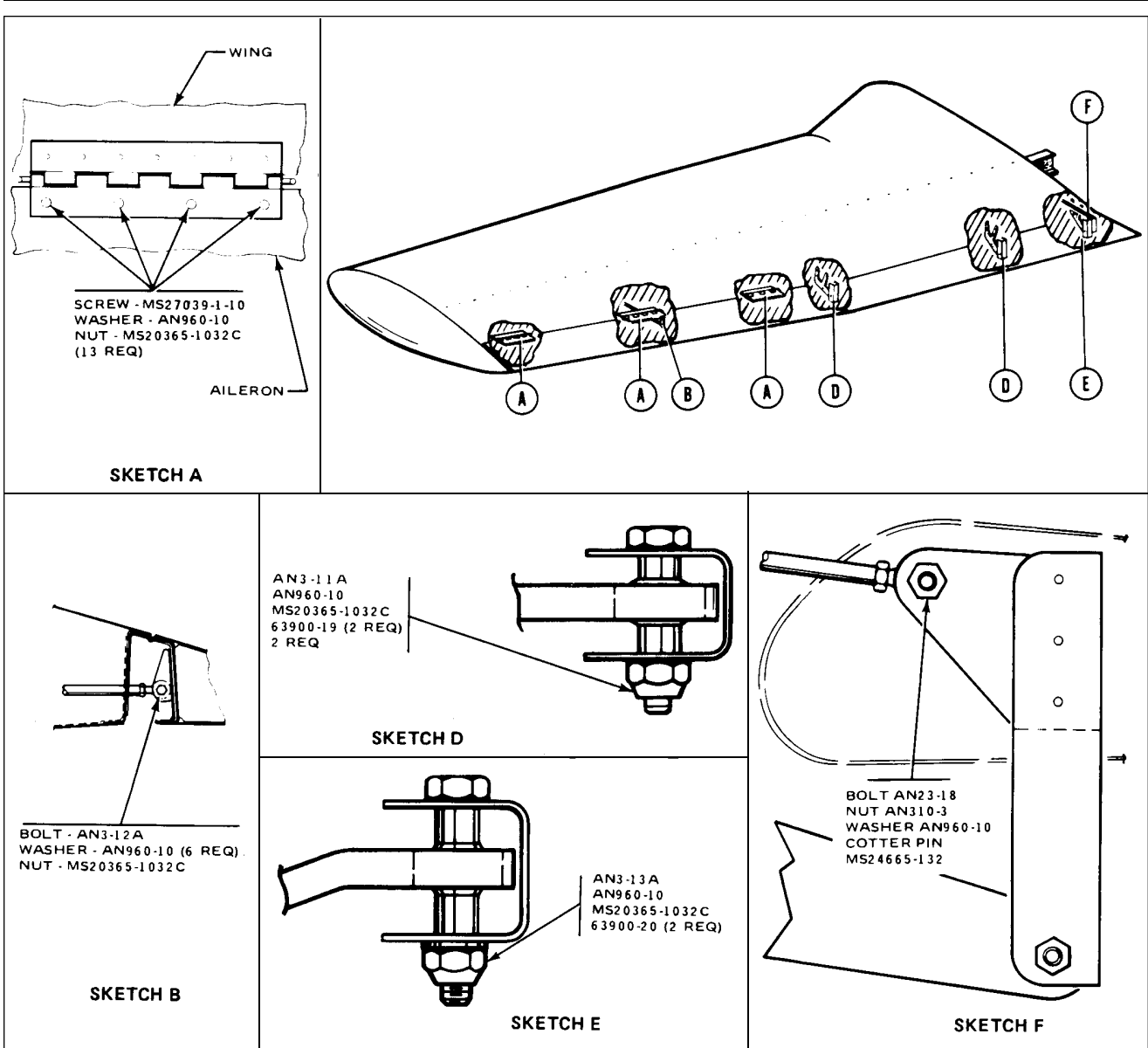

Figure 4-1. Aileron and Flap Installation

* CHEROKEE ARROW III SERVICE MANUAL

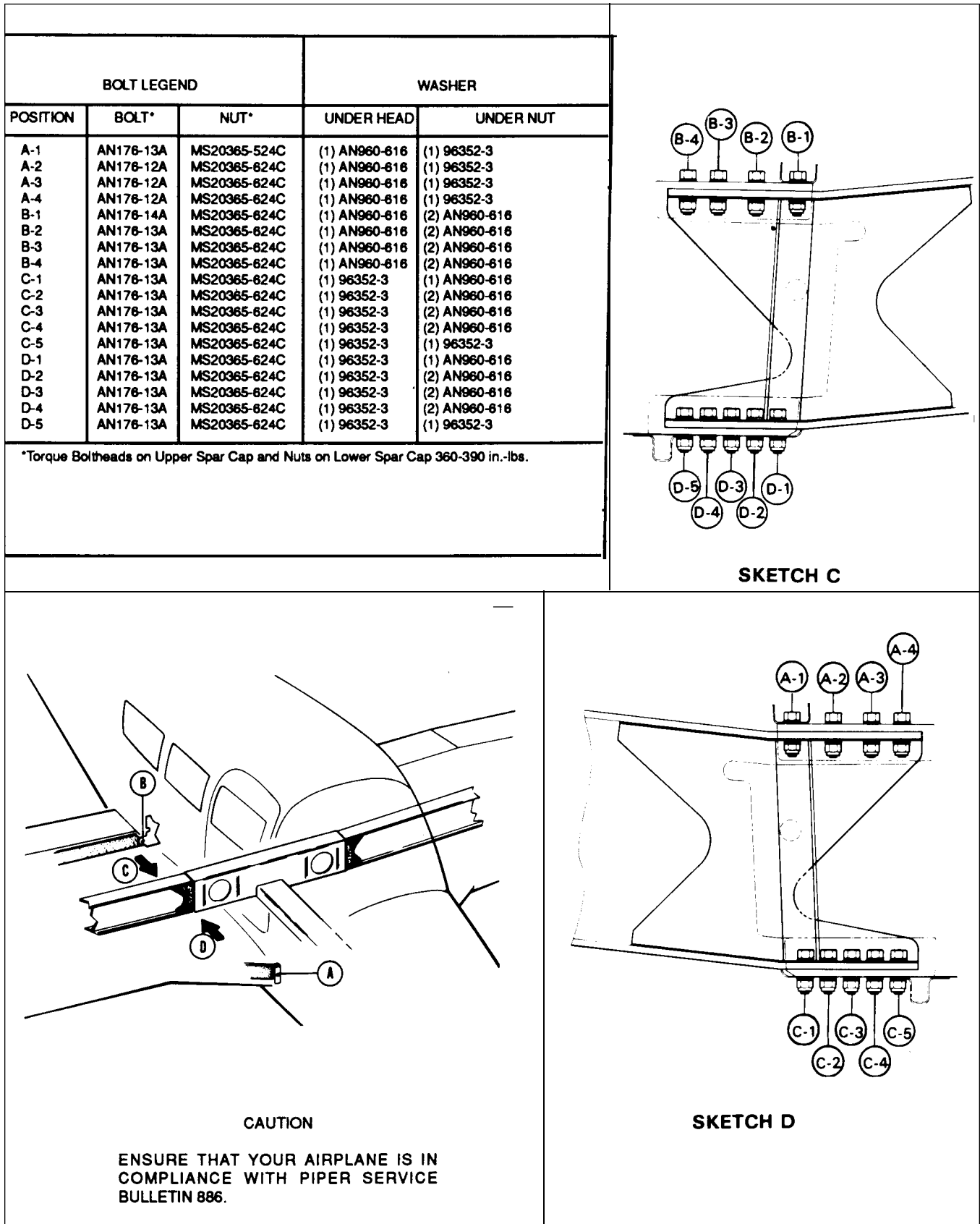

Figure 4-2. Wing Installation

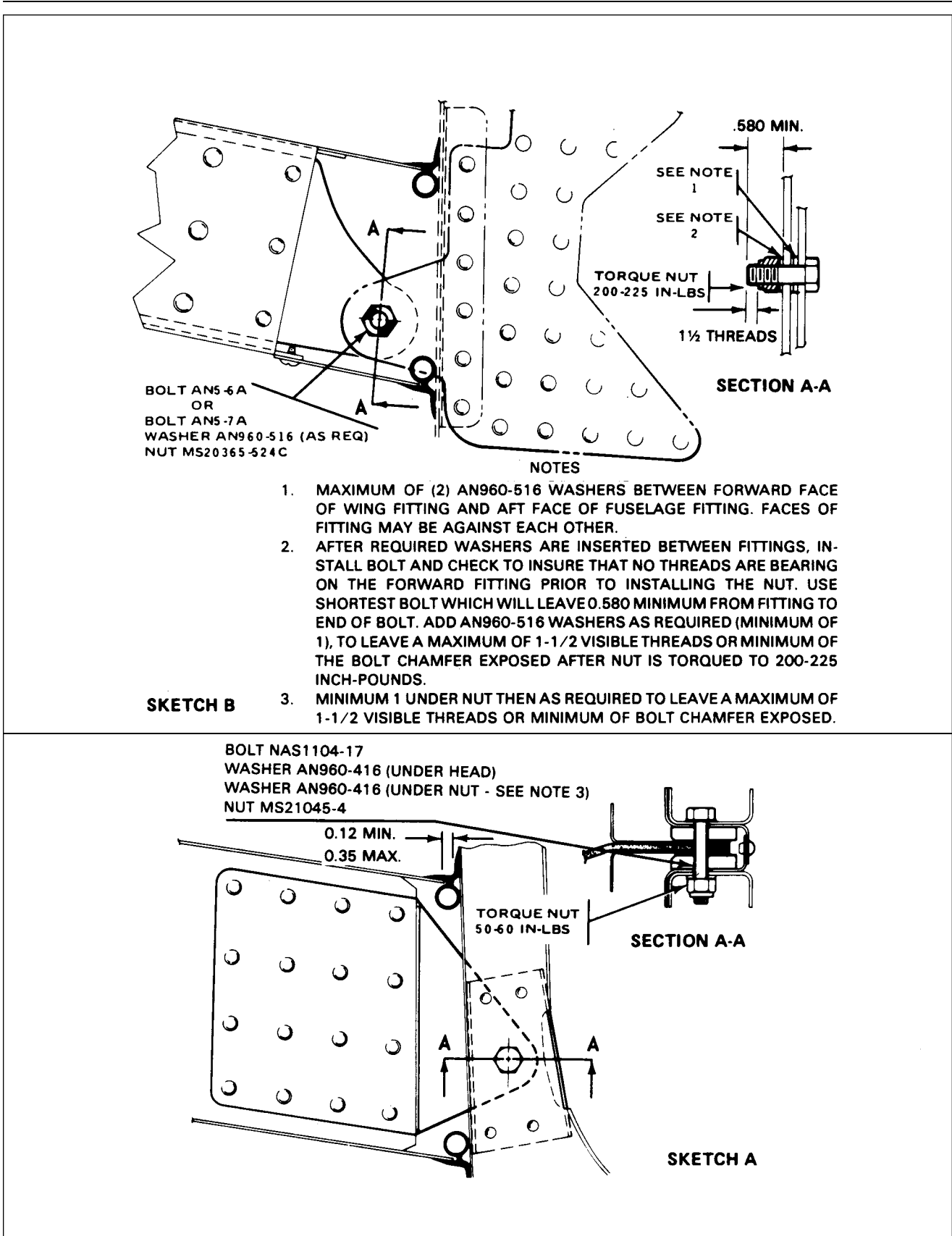

Figure 4-2. Wing Installation (cont)

4-12. INSTALLATION OF WING FLAP. (Refer to Figure 4-1.)

- a. Replace the wing flap by placing the flap onto its proper position and inserting the hinge bolts, bushings, washers, and nuts.
- b. With the flap control in the full flap position, place the bushing on the outboard side of the rod end bearing and insert and tighten the bolt.
- c. Operate the flap several times to be certain it is operating freely.

4-13. WING.

4-14. REMOVAL OF WING. (Refer to Figure 4-2.)

- a. Close the fuel valve and drain the fuel from the wing to be removed. (Refer to Draining Fuel System, Section II.)
- b. Drain the brake lines and reservoir. (Refer to Draining Brake System, Section II.)
- c. Drain the hydraulic lines of the landing gear of the wing to be removed by separating the lines and elbows at the actuating cylinder.
- d. Remove the access plate at the wing butt rib and wing inspection panels. (Refer to Access Plates and Panels, Section II.)
- e. Remove the front and back seats from the airplane.
- f. Expose the spar box and remove the side trim cockpit panel assembly that corresponds with the wing being removed.
- g. Place the airplane on jacks. (Refer to Jacking, Section II.)

NOTE

To help facilitate reinstallation of control cables, and fuel and hydraulic lines, mark cable and line ends in some identifying manner and attach a line where applicable to cables before drawing them through the fuselage or wing.

- h. Disconnect the aileron balance and control cables at the turnbuckles that are located within the fuselage aft of the spar.
- i. If the left wing is being removed, remove the cotter pin from the pulley bracket assembly to allow the left aileron balance cable end to pass between the pulley and bracket.
- j. Disconnect the flap from the torque tube by extending the flap to its fullest degree, and removing the bolt and bushing from the bearing at the aft end of the control rod.
- k. Disconnect the fuel line at the fitting located inside of the wing, by removing the access panel on the forward inboard portion of the wheel well and reaching through to the fuel line coupling.

CAUTION

To prevent damage or contamination of fuel, hydraulic and miscellaneous lines, place a protective cover over the line fittings and ends.

- l. Remove the clamps that are necessary to release the electrical harness assembly. Disconnect the leads from the terminal strip by removing the cover, and appropriate nuts and washers.
- m. With the appropriate trim panel removed, disconnect the hydraulic brake line at the fitting located within the cockpit at the leading edge of the wing.
- n. Disconnect the landing gear hydraulic lines at the fittings aft of the spar and within the fuselage.

- o. If the left wing is being removed, it will be necessary to disconnect pitot tube at the elbow located within the cockpit at the wing butt line.
- p. Arrange a suitable fuselage cradle and supports for both wings.
- q. Remove the wing jacks.
- r. Remove the front and rear spar nuts, washers and bolts.
- s. Remove the eighteen main spar bolts.
- t. Slowly remove the wing being certain that all electrical leads, cables and lines are disconnected.

4-15. INSTALLATION OF WING. (Refer to Figure 4-2.)

- a. Ascertain that the fuselage is positioned solidly on a support cradle.
- b. Place the wing in position for installation, with the spar end a few inches from the side of the fuselage and set on trestles.
- c. Prepare the various lines, control cables, etc. for inserting into the wing or fuselage when the wing is eased into place.
- d. Slide the wing into position of the fuselage.
- e. Install the eighteen main spar bolts in accordance with the bolt legend.
- f. Install the bolt, washers, and nut that attaches the front spar and fuselage fitting. A minimum of one washer is required under the nut and head of bolt, then add washers as needed to leave a maximum of one and on-half threads visible or a minimum of the bolt chamfer exposed.
- g. Insert the number of washers required at the rear spar between the forward face of the wing fitting and aft face of the fuselage fitting. The maximum number of washers allowed is two of AN960C-516. It is also acceptable to have the faces of the fitting against each other. After the required washers are inserted between the plates, install the bolt and check to insure that no threads are bearing on the forward plate prior to installing the nut. Use the shortest bolt which will leave 0.580 of an inch minimum from the fitting to the end of the bolt. Add washers, AN960-516, as required, (minimum of one), to leave a maximum of one and one-half visible threads, or minimum of the bolt chamfer exposed after the nut is torqued.
- h. Torque the bolt heads on the upper spar cap and the nuts on the lower spar cap 360 to 390 inch pounds. Be certain that the bolts, nuts and washers are installed in accordance with the bolt legend. (Figure 4-2.) The forward spar attachment nut should be torqued 50 to 60 inch pounds. Torque the rear spar attachment nut from 200 to 225 inch pounds.
- i. Install the wing jacks and the tail support to the tail skid with approximately 250 pounds of ballast on the base of the tail support. Remove the fuselage cradle and wing supports.
- j. If the left wing was removed, it is necessary that the pitot tube be connected at the elbow located within the cockpit at the wing butt line. Replace or install clamps where found necessary.
- k. Connect the hydraulic brake line onto the fitting located within the cockpit at the leading edge of the wing, and the landing gear hydraulic lines at the fittings within the fuselage aft of the spar.
- l. Connect the leads to the appropriate posts on the terminal strip and install the washers and nuts. (For assistance in connecting the electrical leads, refer to the electrical schematics in Section XI.) Place the clamps along the electrical harness to secure it in position and install the terminal strip dust cover.
- m. Connect the fuel line at the fitting located inside of the wing, by reaching through the access panel on the forward inboard portion of the wheel well.
- n. Connect the aileron balance and control cables at the turnbuckles that are located within the fuselage aft of the spar. After the left balance cable has been inserted through the bracket assembly and connected, install a cotter pin cable guard into the hole that is provided in the bracket assembly.
- o. Connect the flap by placing the flap handle in the full flap position, place the bushing on the outside of the rod end bearing, and insert and tighten bolt.
- p. Check the rigging and control cable tension of the ailerons and flaps. (Refer to Rigging and Adjustment of Ailerons, and Rigging and Adjustment of Flaps, Section V.)

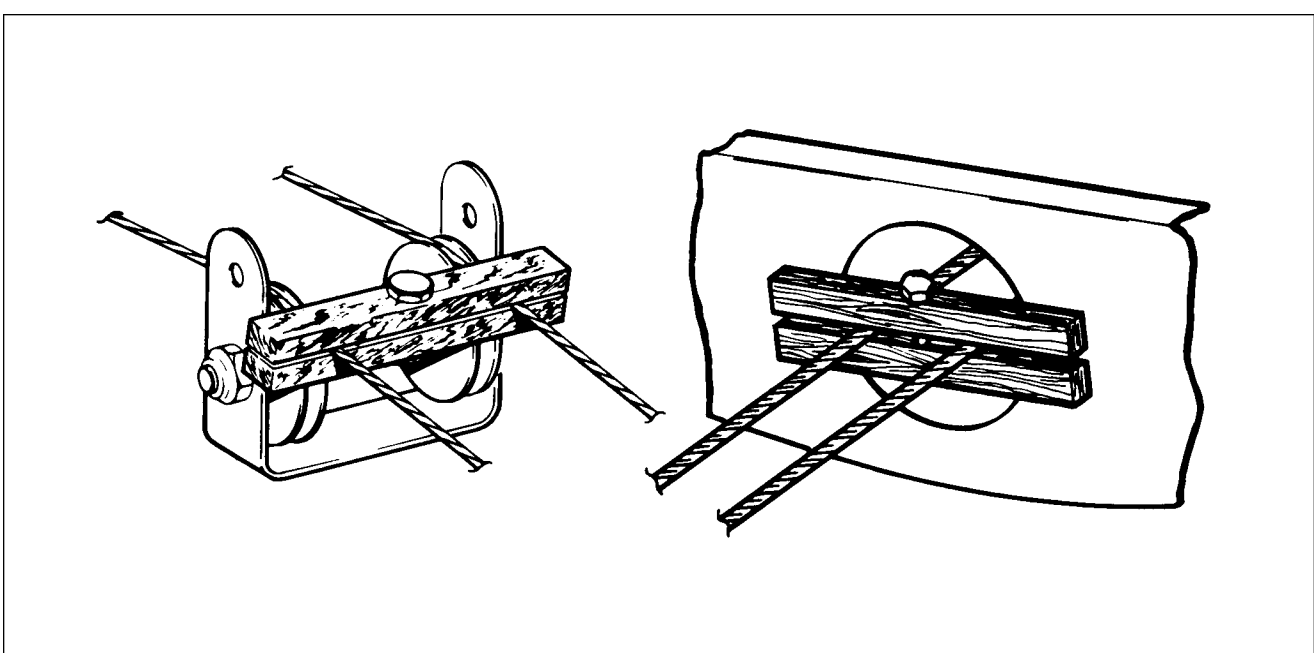

Figure 4-3. Methods of Securing Control Cables

- q. Service and refill the brake system with hydraulic fluid in accordance with Servicing Brake System, Section II. Bleed the system as given in Section VII and check for fluid leaks.
- r. Check the fluid level of the landing gear hydraulic system and fill in accordance with Servicing Hydraulic Pump/Reservoir, Section II. With the airplane setting on jacks, operate the gear through several retraction and extension cycles to be certain that there are no hydraulic leaks. Bleed the hydraulic system in accordance with Section VI.
- s. Service and fill the fuel system in accordance with Servicing Fuel System, Section II. Open the fuel valve and check for leaks and flow.
- t. Check the operation of all electrical equipment and pitot systems.
- u. Remove the airplane from jacks.
- v. Install the cockpit trim panel assembly, spar box carpet, the front and back seats and wing root rubber.
- w. Replace all the access plates and panels on the wing involved.

4-16. EMPENNAGE GROUP.

4-17. STABILATOR.

4-18. REMOVAL OF STABILATOR. (Refer to Figure 44.)

NOTE

Before entering the aft portion of the fuselage, attach a stand to the tail skid for support; and with the use of a heavy pad, protect the inside of the fuselage. Be certain to distribute weight on top of the bulkheads so as not to damage the fuselage skin.

NOTE

Should it be necessary to move the rudder to its extreme left or right for clearance, do so with the use of the rudder pedals or tow bar.

- a. Remove the screws from around the upper and lower tail cone fairing assembly and remove the fairing separately.
- b. Block the trim cable at the barrel of the trim screw assembly to prevent the cable from unwrapping.
- c. Remove the access panel to the aft section of the fuselage located at the back wall of the baggage compartment.
- d. Install cable blocks as illustrated in Figure 4-3 on the stabilator trim control cable at the first set of pulleys forward of the cable turnbuckles to prevent the forward cable from unwrapping.
- e. Disconnect the trim cables at the turnbuckles within the aft section of the fuselage.
- f. Relieve tension from the stabilator control cables by loosening one of the cable turnbuckles in the aft section of the fuselage.
- g. Disconnect the stabilator control cables from the stabilator balance arm by removing cotter pins, nuts, washers, bushings and clevis bolts.
- h. Disconnect the trim assembly from the aft bulkhead of the fuselage by removing the attaching nuts, washers and bolts of the horizontal and diagonal support brackets.
- i. Move the trim assembly up through the tail cone fairing cutout in the stabilator and remove, with cable, from the airplane.
- j. Remove the stabilator by disconnecting the stabilator at its hinge points.

4-19. INSTALLATION OF STABILATOR. (Refer to Figure 4-4.)

CAUTION

Comply with latest revision of Piper Service Bulletin 856.

NOTE

A clearance of .25 +/- .06 of an inch between the stabilator and the side of the fuselage and .18 of an inch minimum between all parts of the stabilator and the tail cone assembly must be maintained throughout the stabilator travel. Use a proper washer combination on the stabilator hinges to attain the necessary tolerances.

- a. Insert the stabilator in position and install attaching hinge bolts, washers and nuts.
- b. Move the trim assembly through the cutout in the stabilator and attach the brackets of the assembly to the aft bulkhead with bolts, washers and nuts. Insert the trim cable ends into the fuselage.
- c. Attach the stabilator control cables to the stabilator balance arm with clevis bolts, bushings, washers, nuts and cotter pins.
- d. Connect the ends of the fore and aft trim cables at the turnbuckles within the aft section of the fuselage.
- e. Remove the cable block from the trim control cable within the fuselage.
- f. Set the stabilator control cable tension and check rigging and adjustment according to Rigging and Adjustment of Stabilator, Section V.
- g. Remove the cable blocks from the trim cable at the barrel of the trim screw assembly.
- h. Set stabilator trim control cable tension and check rigging and adjustment according to Rigging and Adjustment of Stabilator Trim, Section V.
- i. Remove the pad from the aft section of the fuselage and replace the access panel.
- j. Install the tail cone fairing and remove tail stand.

4-20. STABILATOR TRIM TAB.

4-21. REMOVAL OF STABILATOR TRIM TAB. (Refer to Figure 4-4.)

- a. Disconnect the stabilator trim control rod by removing the bolts that attach the control rod to the stabilator trim tab.
- b. Remove the stabilator trim hinge pins by cutting one end of the wire pins and removing.
- c. The stabilator trim tab can now be removed.

4-22. INSTALLATION OF STABILATOR TRIM TAB. (Refer to Figure 4-4.)

- a. Place the trim tab in position on the aft end of the stabilator.
- b. Replace the old hinge pins. Refer to Parts Catalog for replacement pins.
- c. Insert the pins and secure by bending the end to a 45 degree angle.
- d. Install the control rod and attach with the four bolts and washers.

4-23. RUDDER.

4-24. REMOVAL OF RUDDER.

- a. Remove the screws from around the upper tail cone fairing assembly and remove the fairing.
- b. Remove the rudder tip by removing the attaching screws and disconnect the tail position light wire at the quick disconnect located at the tip of the rudder. Open the access panel in the rear of the baggage compartment to gain access to the aft section of the fuselage.
- c. Relieve the cable tension from the rudder control system by loosening one of the cable turnbuckles in the aft section of the fuselage.
- d. Disconnect the two control cables from the rudder horn by removing the cotter pins, nuts, washers, bushings and bolts.
- e. Remove the cotter pins, nuts, washers and bolts from the upper and lower rudder hinge pivot points.
- f. Pull the rudder up and aft from the vertical fn.

4-25. INSTALLATION OF RUDDER. (Refer to Figure 4-4.)

- a. Place the rudder in position and install the hinge bolts, washers, nuts and cotter pins.

NOTE

Use any washer combination of the hinge assembly to suit best, the centering and operation of the rudder.

- b. Connect the tail position light electrical lead at the quick disconnect and cover the connector with an insulating sleeve. Tie both ends of the sleeve with number six electrical lacing twine.
- c. Connect the control cables to the rudder horn with bolts, washers, nuts and cotter pins.
- d. Check the rudder in accordance with Rigging and Adjustment of Rudder, Section V.
- e. Install the upper tail cone fairing and rudder tip and secure with the attachment screws. Secure the access panel to the aft section of fuselage.

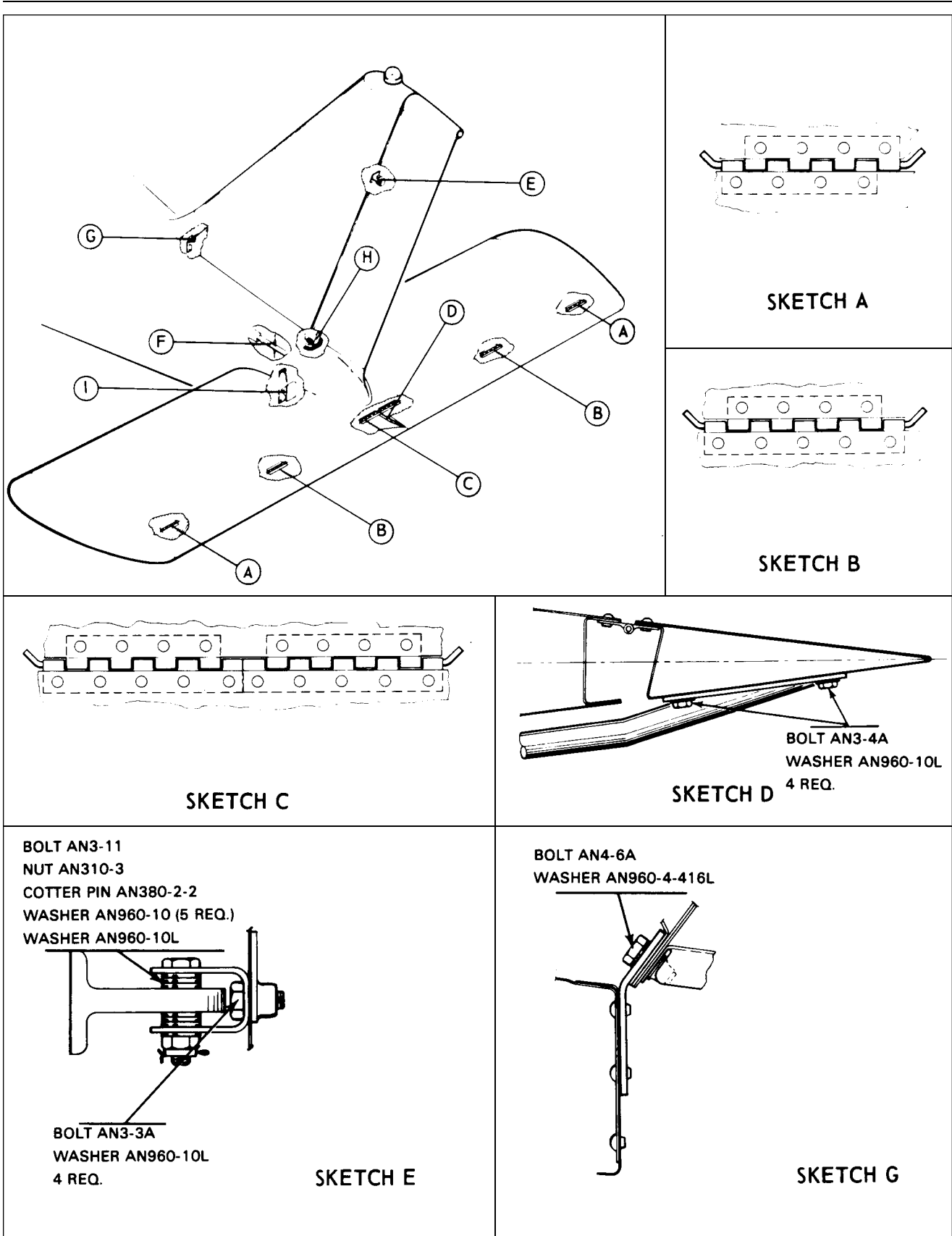

Figure 4-4. Empennage Group Installation

*** CHEROKEE ARROW III SERVICE MANUAL**

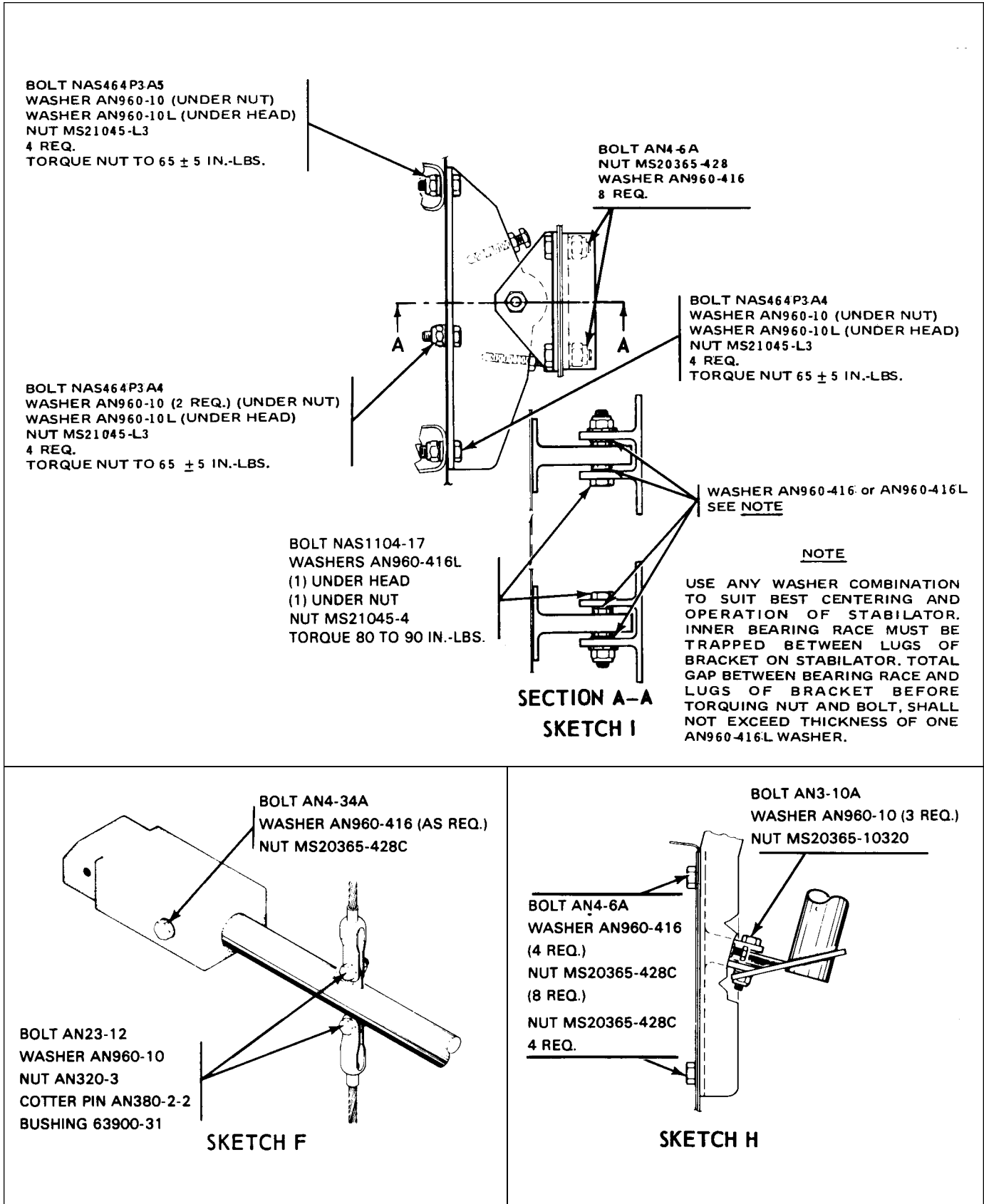

Figure 4-4. Empennage Group Installation (cont)

4-26. VERTICAL FIN.

4-27. REMOVAL OF VERTICAL FIN.

- a. Remove the screws from the upper and lower tail cone fairing, the fin tip cover and the fairing at the forward base of the fin.
- b. Remove the rudder per instructions given in Paragraph 4-24.
- c. Disconnect the leads from the antenna terminals (optional) and attach a line to the leads to assist in reinstallation.
- d. Disconnect the wire antenna (optional) that attaches to the leading edge of the fin.
- e. Disconnect the positive lead to the rotating beacon (optional) and attach a line prior to removal. Disconnect the ground lead by removing the attachment screw.
- f. Remove the stabilator trim assembly and aft trim cable in accordance with Removal of Stabilator Trim Assembly (Aft), Section V.
- g. Remove the bolt and washer that attaches the leading edge of the fin to the fuselage.
- h. Remove the nuts, washers and bolts that secure the fin spar to the aft bulkhead and remove the vertical fin.

4-28. INSTALLATION OF VERTICAL FIN.

- a. Insert the vertical fin into position and install the bolts, washers and nuts that secure the fin spar to the aft bulkhead.
- b. Install the bolt and washer that attaches the leading edge of the fin to the fuselage.
- c. Install the stabilator trim assembly and aft trim cable per instructions given in Installation of Stabilator Trim Assembly, Section V.
- d. Install the rudder per Paragraph 4-25.
- e. Pull the electrical and antenna leads through the vertical fin with the line that was attached.
- f. Connect the antenna leads to the proper terminals and secure with washers and nuts.
- g. Connect the electrical leads at the disconnects and insulate.
- h. Rig and adjust the rudder and trim control cables as given in Section V.
- i. Check the operation of the radios and electrical lights.
- j. Replace all fairings and access plates, and secure with attaching screws.

4-29. FUSELAGE ASSEMBLY.

4-30. WINDSHIELD.

4-31. REMOVAL OF WINDSHIELD.

- a. Remove the collar molding from around the bottom of the windshield and the trim strip from between the windshield halves by removing the attaching screws.
- b. Remove the windshield by raising the lower portion of the windshield and carefully pulling it out and downward to release the top and side edges.

NOTE

A damaged windshield should be saved since it can be used as a pattern for drilling required holes in the new windshield.

- c. Clean the old tape and sealer from the windshield channels, strips and divider post.

* CHEROKEE ARROW III SERVICE MANUAL

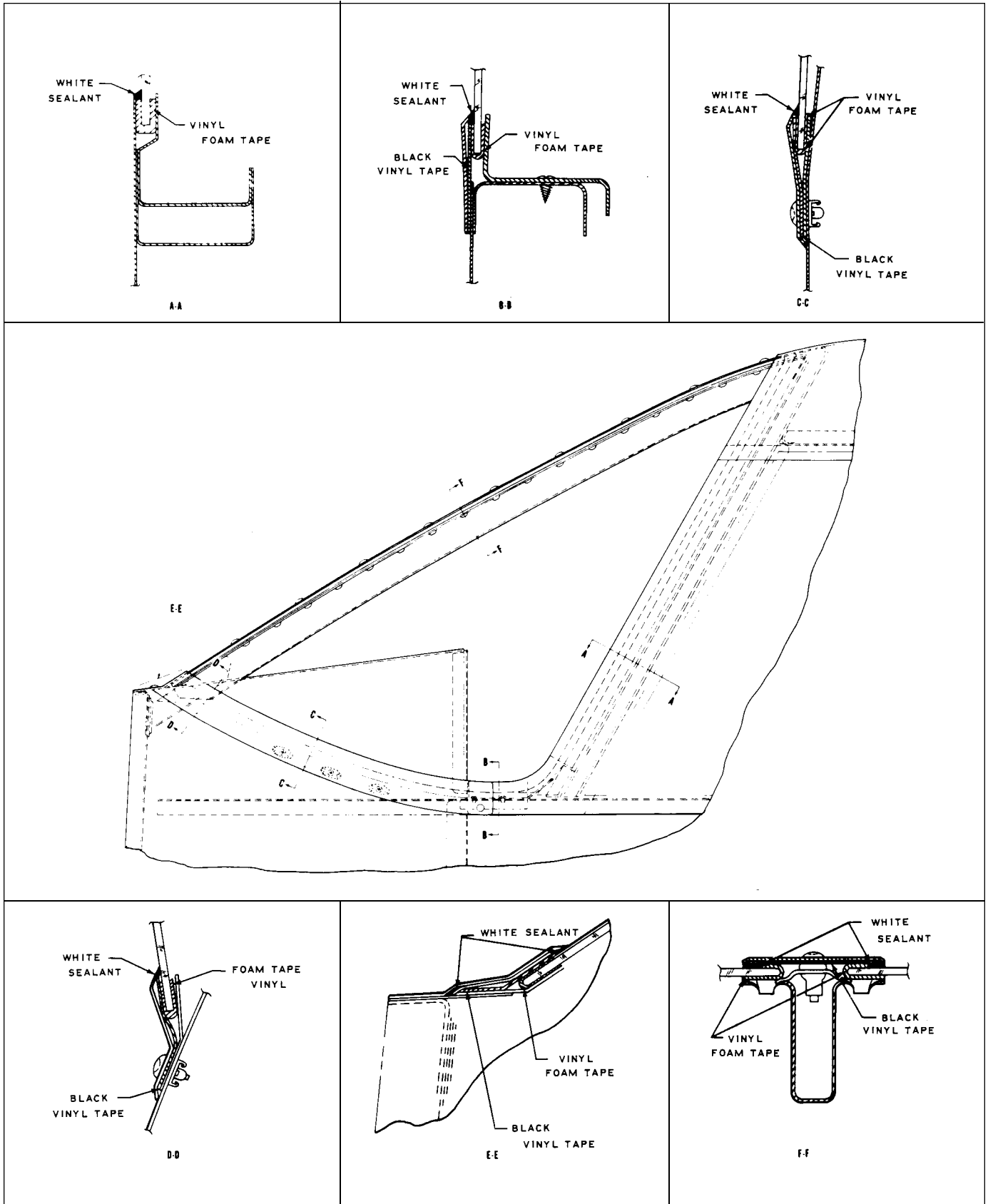

Figure 4-5. Windshield Installation (Typical)

4-32. INSTALLATION OF WINDSHIELD. (Refer to Figure 4-5.)

- a. Be certain that the new windshield outside contours are the same as that of the old windshield. It may be found that it is necessary to cut or grind the new windshield to acquire the proper dimensions.
- b. Apply black vinyl plastic tape around the outer edges of the entire windshield.
- c. Apply Behr-Manning vinyl foam tape number 560 or equivalent over the plastic tape, completely around the edges of the windshield.
- d. Apply Behr-Manning sealant number PR 307 or equivalent under edge of the moldings and trim strips.
- e. Place the windshield in position for installation and slide the windshield aft and up into place, using caution not to dislocate the tape around the edges. Allow clearance between the two windshields at the divider post for expansion.
- f. Lay sealant at the bottom and center (inboard) of the windshield in the hollow between the outside edge and channel.
- g. Lay a small amount of sealant under the center trim strip, install and secure.
- h. Lay black vinyl tape on the underside of the collar molding, install and secure.
- i. Seal with sealant any areas around windshield that may allow water to penetrate past the windshield.
- j. Remove excess exposed sealer to tape.

4-33. SIDE WINDOWS.

4-34. REMOVAL OF SIDE WINDOWS.

- a. Remove the retainer molding from around the window by removing the attachment screws.
- b. Carefully remove the window from the frame.

NOTE

A damaged window should be saved to provide a pattern for shaping the new window.

- c. Remove excess tape and sealer from the window frame and molding.

4-35. INSTALLATION OF SIDE WINDOWS. (Refer to Figure 4-6.)

- a. Cut or grind the new window to the same dimension as the window removed.
- b. Apply Behr-Manning vinyl foam tape number 560 or equivalent, on both sides of the window around the outer edges.
- c. Apply Behr-Manning sealant number PR 307 or equivalent, completely around the outer surface of the windows at all attachment flanges.
- d. Insert the window in the frame and install the retainer moldings.
- e. Secure the molding with attachment screws and tighten until the vinyl foam tape is 25% compressed by the retainers.
- f. Remove the excess exposed sealer and tape.

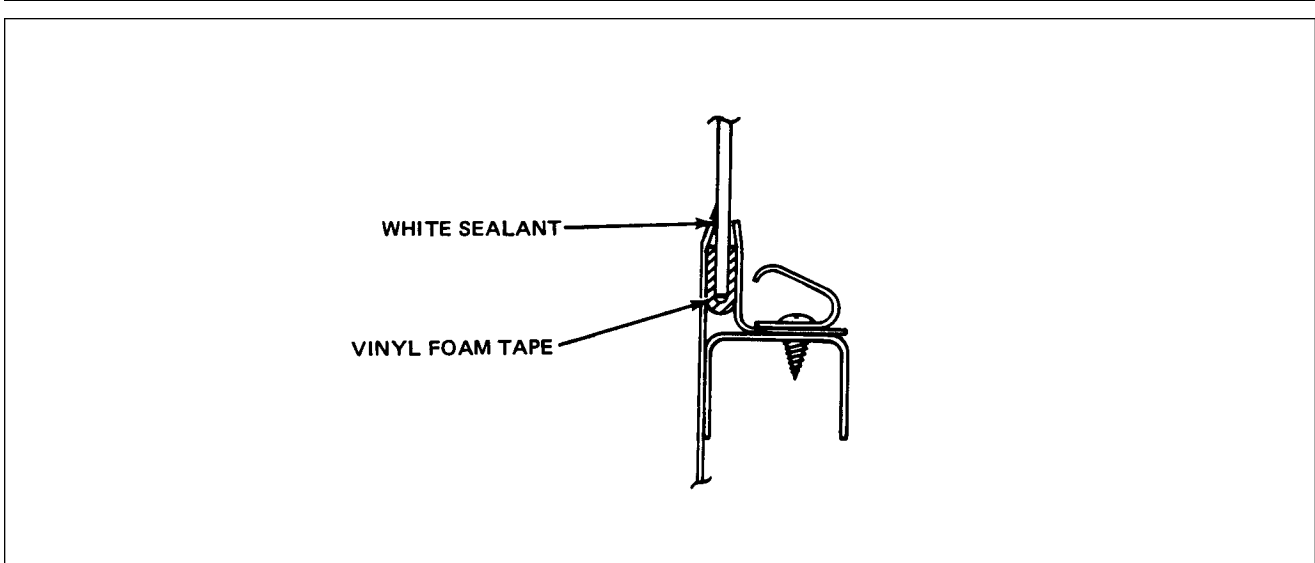

Figure 4-6. Side Window Installation (Typical)

4-36. DOOR (ENTRANCE).

4-37. REMOVAL OF DOOR.

- a. Remove the clevis bolt, washer and bushing from the door holder assembly.
- b. Remove cotter pins, clevis pins and washers from serrated door hinges.
- c. Remove the door from the airplane.

4-38. INSTALLATION OF DOOR.

- a. Insert the door into position and install the washers, clevis bolts and cotter pins on the door hinges.
- b. For adjustment of door, refer to Paragraph 4-39.
- c. Hook up and install the clevis bolt, bushing and washer into the door holder assembly.

4-39. ADJUSTMENT OF DOOR.

- a. To acquire the proper vertical adjustment of the door, insert the necessary washer combination between the cabin door hinge and fuselage bracket assembly.
- b. Additional adjustments may be made by tapping out the serrated door hinge, bushings and rotating them to obtain the hinge centerline location that will provide proper door fit.
- c. To insure long life of door seals and improve sealing characteristics, it is recommended they be lubricated with a fluorocarbon or similar dry lubricant in a spray can.

4-40. REMOVAL OF DOOR LATCH MECHANISM.

- a. Remove the door latch mechanism by removing the door trim upholstery and the screws that attach the latch plate and latch mechanism to the door.
- b. Disconnect the latch pull rod from the inside door handle.
- c. Remove the complete latch mechanism.

*** CHEROKEE ARROW III SERVICE MANUAL**

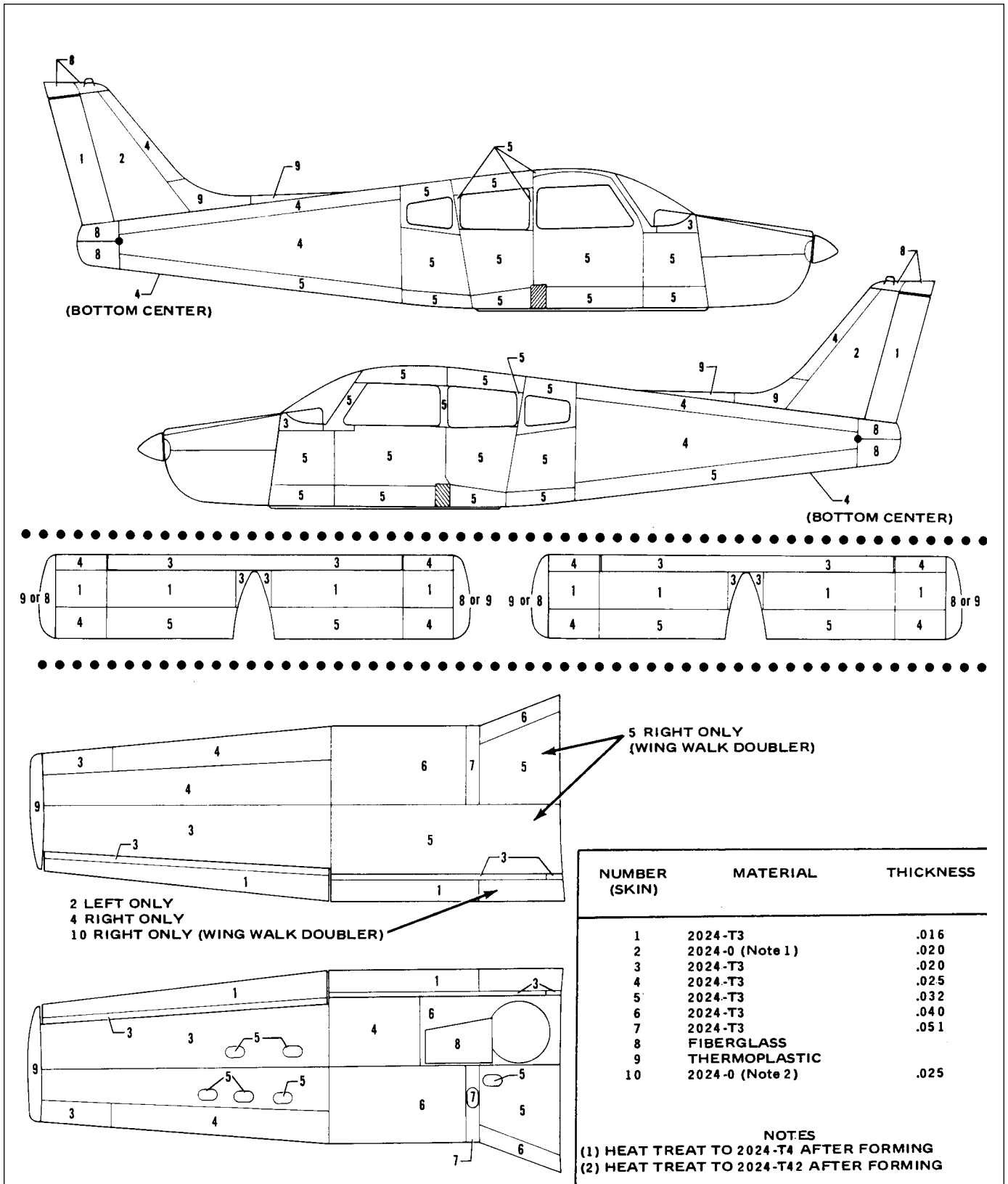

Figure 4-7. Skin Materials and Thickness

4-41. INSTALLATION OF DOOR LATCH MECHANISM.

- a. Place the latch assembly into position on the door.
- b. Connect the latch pull rod to the inside door handle.
- c. Replace the screws that attach the latch plate and mechanism to the door. Install the door trim upholstery and secure with screws.

4-42. ADJUSTMENT OF DOOR LATCH MECHANISM. To adjust the door latch, loosen the screws on the striker plate, make necessary adjustment, and retighten the screws.

4-43. REMOVAL OF DOOR LOCK ASSEMBLY.

- a. Remove the door trim upholstery by removing the attachment screws.
- b. Loosen the nut on the lock assembly and remove the lock by turning it sideways.

4-44. INSTALLATION OF DOOR LOCK ASSEMBLY.

- a. Install the lock in the door by turning it sideways and placing it through the opening provided.
- b. Replace the nut on the back of the lock assembly and tighten.
- c. Replace the door trim upholstery and secure with the attachment screws.

4-45. REMOVAL OF DOOR SAFETY LATCH.

- a. Remove the two handles and the five screws holding the pan on the inside of the door.
- b. Remove the pan and pull the latch assembly through the opening on the door.

4-46. INSTALLATION OF DOOR SAFETY LATCH.

- a. Place the latch assembly into position for installation.
- b. Replace the pan and install the five screws and handles.
- c. Check the latch assembly for operation and be certain that it is free of rubbing on the trim panels.

4-47. ADJUSTMENT OF DOOR SAFETY LATCH.

- a. To adjust the door safety latch remove the two screws from latch plate found at the top of the door opening.
- b. Remove the plate and turn the loop assembly in or out to make necessary adjustments.
- c. Replace the latch plate and secure with the two attachment screws.

4-47a. REMOVAL AND INSTALLATION OF DOOR SEAL SNUBBERS.

- a. If the existing door seal is torn or has deteriorated it should be replaced. If rebonding is required use:
 1. 3M EC 1300L (preferred)
 2. Proco Adhesive 6205-1
 3. Scotch Grip 2210
- b. Remove windlace retainers. Expose the door jamb by rolling back and taping the windlace.
- c. Disconnect the door-holder attached to the lower door jamb and remove scuff plate.
- d. Remove the striker plate. (Refer to Figure 4-7a.)
- e. Remove the snubber as follows:
 1. Apply mineral spirits to the snubber to loosen the adhesive.
 2. Using a plastic scraper (or other appropriate instrument), scrape off the snubber while applying mineral spirits as necessary.
 3. With the snubber removed, use a clean cloth and mineral spirits to remove excess adhesive.

CHEROKEE ARROW III SERVICE MANUAL

f. Installation of the door seal snubber is as follows:

1. If the door jamb paint is flaking or is excessively scuffed, rub down with wet and dry emery cloth. Clean the surface with Prep-Sol or equivalent cleaner which will not leave an oily residue.

NOTE

The normal "tack time" for 3M EC 1300L is 30 to 45 minutes at 75° F. However, adhesive which has "set" may be reactivated by a clean rag moistened with Toluol or Methylethylketone.

2. To effect a clean installation it is recommended that the door jamb is masked off with tape as shown in Figure 4-7a, View D.
3. Apply adhesive to the door jamb with a small brush on the area indicated in Figure 4-7a, View D.
4. Apply adhesive to the inside surface of the snubber.
5. Position the snubber with the protruding leg facing outboard beginning at the lower center (± 2 inches) of the door jamb. Work progressively around the door jamb applying pressure to the snubber to remove any trapped air and to ensure the edges are effectively bonded to the jamb.

NOTE

Do not stretch the rubber, especially in the corner areas, as this can cause cracks.

6. It takes approximately one day for the bond to cure. It is recommended that the door be kept open as long as possible during this time to effect maximum curing.
7. Remove masking tape if used and clean off excessive adhesive using a clean cloth and mineral spirits or Toluol.
8. Install the striker plate.
9. Reposition the windlace and secure with retainers previously removed.
10. Install the scuff plate and door holder previously removed.
11. Adjust the door latch to compensate for the snubber, ensuring a good door to fuselage contour fit with no increase in latching effort.
12. After all adjustments and curing have been accomplished, coat the snubber with silicone - wipe off any excess.

4-48.BAGGAGE DOOR.

4-49.REMOVAL OF BAGGAGE DOOR. With the door open remove the hinge pin from the hinge and remove the door.

4-50.INSTALLATION OF BAGGAGE DOOR. Place the door in position so that the hinge halves are properly matched and install the hinge pin. It will not be necessary to replace the hinge pin with a new pin if it is free of bends and wear.

4-51.REMOVAL OF BAGGAGE DOOR LOCK ASSEMBLY

- a. With the door open remove the nut from the back of the lock assembly by use of a special made wrench. (This tool may be fabricated from the dimensions given in Figure 4-8.)
- b. Remove the lock assembly through the front of the door.

4-52. INSTALLATION OF BAGGAGE DOOR LOCK ASSEMBLY.

- a. Place the lock into position for installation.
- b. Install the nut on the lock assembly and tighten with the use of a special wrench.

CHEROKEE ARROW III SERVICE MANUAL

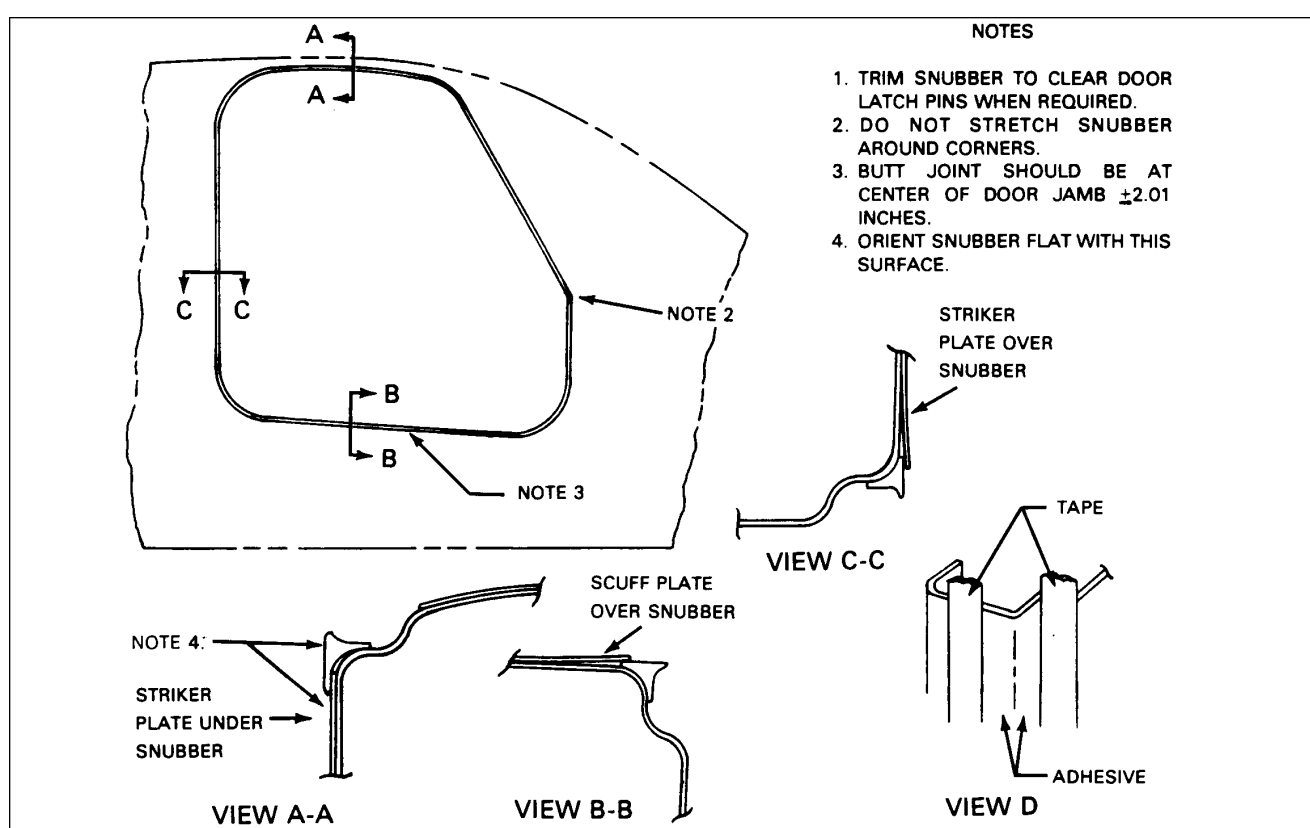

Figure 4-7a. Door Seal Snubber Installation

4-53.REMOVAL OF BAGGAGE DOOR HINGE.

- a. Remove the door from the airplane as described in Removal of Baggage Door, Paragraph 4-49.
- b. Remove the hinge half from the airplane or door by drilling out the rivets and removing the hinge.

4-54.INSTALLATION OF BAGGAGE DOOR HINGE.

- a. Place the hinge halves together and install the hinge pin.
- b. Install the door into the closed position and drill the two end rivet holes and install the rivets.
- c. Operate the door and check for proper fit and installation. Drill the remaining holes and install the rivets.

4-55.STRUCTURAL REPAIRS. Structural repair methods used must be made in accordance with the regulations set forth in FAA Advisory Circular 43.13-1A. To assist in making repairs and/or replacements, Figure 4-7 identifies the type and thickness of various skin material used. never make a skin replacement or patch plate from material other than the type of the original skin, or of a different thickness than the original skin. The repair must be as strong as the original skin. However, flexibility must be retained so the surrounding areas will not receive extra stress.

WARNING

NO access holes are permitted in any control surfaces.

WARNING

The use of patch plates for repairs of all movable tail surfaces is prohibited. The use of any filler material normally used for repair of minor dents and/or materials used for filling the inside of surfaces is also prohibited on all movable tail surfaces.

CHEROKEE ARROW III SERVICE MANUAL

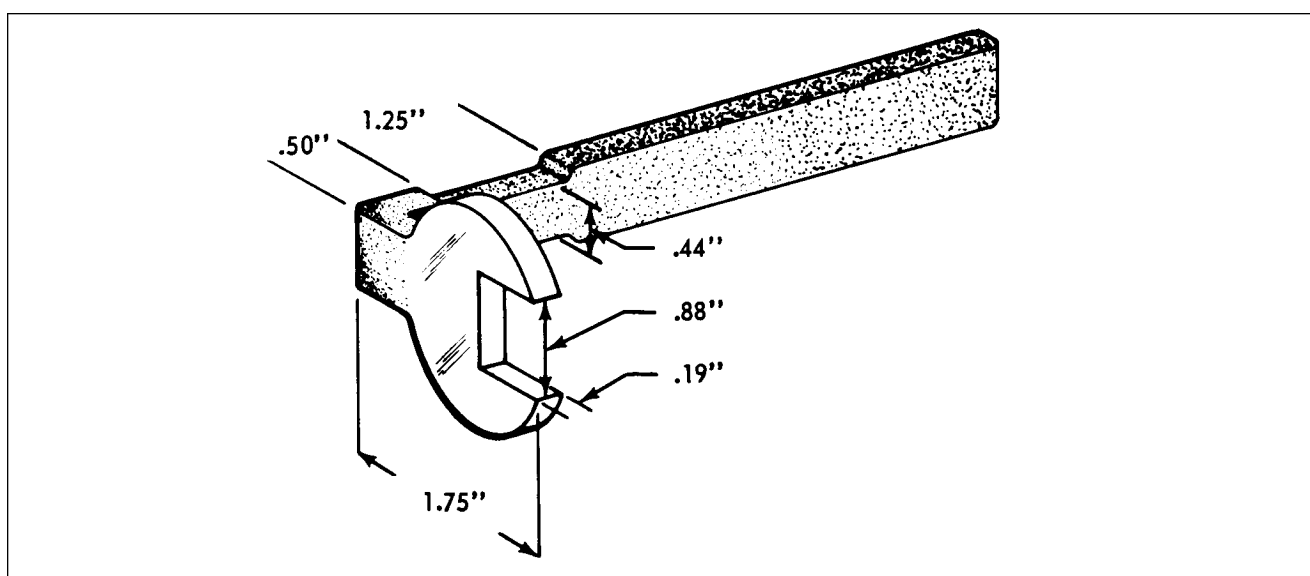

Figure 4-8. Fabricated Tool for Baggage Door Lock

4-55a. BAGGAGE COMPARTMENT INSPECTION HOLE AND COVER PLATE. (See latest revision of Piper Service Bulletin 977.)

a. General.

Airplanes manufactured before 1979 may not have had control cable inspection access holes in the baggage compartment floor. The following is a method of fabricating inspection access holes in the floor of the baggage compartment, if desired.

b. Baggage Compartment Inspection Holes Fabrication Procedure. (Refer to Figure 4-8a.)

While Figure 4-8a shows the hole in the left side of the baggage compartment, a similar hole is also cut out in the right side baggage compartment floor. Installation will require two each inspection access covers, Piper P/N 62109-00.

1. Layout cut lines

- (a) Gain access to baggage compartment.
- (b) **Carefully** remove:
 - (1) Right side baggage compartment Royalite plastic close out panel.
 - (2) Rear close out panel.
 - (3) Carpeting from baggage compartment floor.
- (c) Determine and mark a reference center line running through baggage compartment. Refer to Figure 4-8a for measurements.
- (d) Measure two points 14.99 inches each side of the reference centerline. Joining these two points will form the centerlines of each inspection hole.
- (e) Measure two points on each side of each centerline of both holes at distances of 8.48 inches and 10.98 inches from the aft edge of the baggage compartment floor.
- (f) Connect the two 8.48" points and the two 10.98" points so that the resulting lines cross the centerline of each hole.
- (g) Using the intersection of the lines constructed in step (f) with each hole's centerline as the center, scribe an arc having a radius of 2.00"
- (h) Draw a line (four lines total) tangent to each side of the arcs constructed on step (g).
- (i) There should now be two ovals, like the one in Figure 4-8a, laid out on each side of the baggage compartment floor.

2. Cutting the holes.

— CAUTION —

Baggage compartment flooring is made of 0.025 inch thick aluminum. Use care when cutting through flooring so as not to damage cables and wiring routed below the floor.

- (a) Drill a 1/4 inch hole inside of, and adjacent to, one of the scribed lines layed out for each hole.
 - (b) Using a 1/8 inch router bit, cut out the two inspection holes by following the lines layed out on each side of the baggage compartment floor.
 - (c) Deburr each cut edge using a file or emery wheel.
3. Installing covers.
- (a) Lay one of the 62109-00 covers over one of the inspection holes. Using the screw holes in the cover, scribe the position for the screw holes on the baggage compartment floor.
 - (b) Drill a 0.120 inch hole in baggage compartment floor at each position layed out in step (a).
 - (c) Attach cover to flooring with No.8 X 0.38 corrosion resistant steel sheet metal screws.
 - (d) Repeat steps (a) through (c) on remaining hole.
4. Install baggage compartment rear and side close out panels.
5. Install baggage compartment floor carpet.

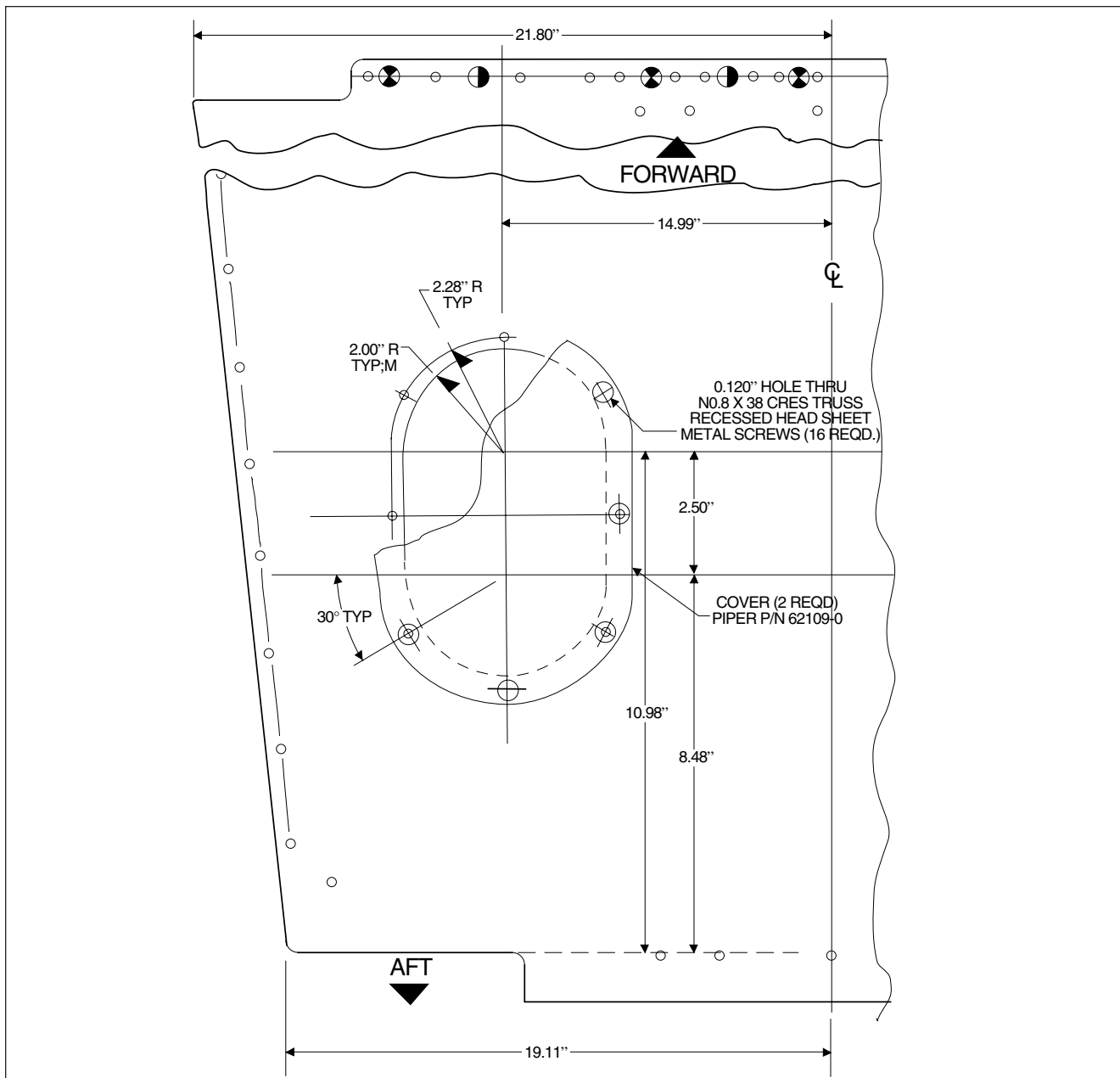

Figure 4-8a. Baggage Compartment Inspection Holes Cutout Details

4-56. FIBERGLASS REPAIRS. The repair procedure in this manual will describe the methods for repair of fiberglass reinforced structures. Paragraph 4-57 describes Fiberglass Touch-Up and Surface Repairs such as blisters, open seams, delamination, cavities, small holes and minor damages that have not harmed the fiberglass cloth material. Paragraph 4-58 describes Fiberglass Fracture and Patch Repairs as puncture, breaks and holes that have penetrated through the structure and damaged the fiberglass cloth. A repair kit, part number 756 729 will furnish necessary material for such repairs, and is available through Piper Aircraft Dealers.

NOTE

Very carefully follow resin and catalyst mixing instructions furnished with repair kit.

4-57. FIBERGLASS TOUCH-UP AND SURFACE REPAIRS.

- a. Remove wax, oil and dirt from around the damaged area with acetone, Methyl ethyl ketone or equivalent and remove paint to gel coat.
- b. The damaged area may be scraped with a fine blade knife or a power drill with a burr attachment to roughen the bottom and sides of the damaged area. Feather the edge surrounding the scratch or cavity. Do not undercut the edge. (If the scratch or cavity is shallow and penetrates only the surface coat, continue to Step h.)
- c. Pour a small amount of resin into a jar lid or on a piece of cardboard, just enough to fill the area being worked on. Mix an equal amount of milled fiberglass with the resin, using a putty knife or stick. Add catalyst, according to kit instruction, to the resin and mix thoroughly. A hypodermic needle may be used to inject gel into small cavities not requiring fiberglass millings mixed with the gel.
- d. Work the mixture of resin, fibers and catalyst into the damaged area, using the sharp point of a putty knife or stick to press it into the bottom of the hole and to puncture any air bubbles which may be present. Fill the scratch or hole above the surrounding undamaged area about 1/16 inch.
- e. Lay a piece of cellophane or waxed paper over the repair to cut off air and start the cure of gel mixture.
- f. Allow the gel to cure 10 to 15 minutes until it feels rubbery to the touch. Remove the cellophane and trim flush with the surface, using a sharp razor blade or knife. Replace the cellophane and allow to cure completely for 30 minutes to an hour. The patch will shrink slightly below the structure surface as it cures. (If wax paper is used, ascertain wax is removed from surface.)
- g. Rough up the bottom and edges of the hole with the electric burr attachment or rough sand paper. Feather hole into surrounding gel coat, do not undercut.
- h. Pour out a small amount of resin, add catalyst and mix thoroughly, using a cutting motion rather than stirring. Use no fibers.
- i. Using the tip of a putty knife or finger tips, fill the hole at about 1/16 inch above the surrounding surface with the gel coat mixture.
- j. Lay a piece of cellophane over the patch to start the curing process. Repeat Step f, trimming patch when partially cured.
- k. After trimming the patch, immediately place another small amount of gel coat on one edge of the patch and cover with cellophane. Then, using a squeegee or the back of a razor blade, squeegee level with area surrounding the patch, leave the cellophane on patch for one or two hours or overnight, for complete cure.
1. After repair has cured for 24 hours, sand patched area using a sanding block with fine wet sandpaper. Finish by priming, again sanding and applying color coat.

4-58.FIBERGLASS FRACTURE AND PATCH REPAIRS.

- a. Remove wax, oil and dirt from around damaged area with acetone, methylethylketone or equivalent.
- b. Using a key hole saw, electric saber saw, or sharp knife cut away ragged edges. Cut back to sound material.
- c. Remove paint three inches back from around damaged area.
- d. Working inside the structure, bevel the edges to approximately a 30 degree angle and rough-sand the hole and the area around it, using 80-grit dry paper. Feather back for about two inches all around the hole. This roughens the surface for strong bond with patch.
- e. Cover a piece of cardboard or metal with cellophane. Tape it to the outside of the structure covering the hole completely. The cellophane should face toward the inside of the structure. If the repair is on a sharp contour or shaped area, a sheet of aluminum formed to a similar contour may be placed over the area. The aluminum should also be covered with cellophane.
- f. Prepare a patch of fiberglass mat and cloth to cover an area two inches larger than the hole.
- g. Mix a small amount of resin and catalyst, enough to be used for one step at a time, according to kit instructions.
- h. Thoroughly wet mat and cloth with catalyzed resin. Daub resin on mat first, and then on cloth. Mat should be applied against structures surface with cloth on top. Both pieces may be wet out on cellophane and applied as a sandwich. Enough fiberglass cloth and mat reinforcements should be used to at least replace the amount of reinforcements removed in order to maintain the original strength. If damage occurred as a stress crack, an extra layer or two of cloth may be used to strengthen area.
- i. Lay patch over hole on inside of structure, cover with cellophane, and squeegee from center to edges to remove all air bubbles and assure adhesion around edge of hole. Air bubbles will show white in the patch and they should all be worked out to the edge. Remove excess resin before it gels on the part. Allow patch to cure completely.
- j. Remove cardboard or aluminum sheet from outside of hole and rough-sand the patch and edge of hole. Feather edge of hole about two inches into undamaged area.
- k. Mask area around hole with tape and paper to protect surface. Cut piece of fiberglass mat about one inch larger than the hole and one or more pieces of fiberglass cloth two inches larger than the hole. Brush catalyzed resin over hole, lay mat over hole and wet out with catalyzed resin. Use a daubing action with brush. Then apply additional layer or layers of fiberglass cloth to build up patch to the surface of structure. Wet out each layer thoroughly with resin.
- l. With a squeegee or broad knife, work out all air bubbles in the patch. Work from center to edge, pressing patch firmly against the structure. Allow patch to cure for 15 to 20 minutes.
- m. As soon as patch begins to set up, but while still rubbery, take a sharp knife and cut away extra cloth and mat. Cut on outside edge of feathering. Strip cut edges of structure. Do this before cure is complete, to save extra sanding. Allow patch to cure overnight.
- n. Using dry 80 grit sandpaper on a power sander or sanding block, smooth patch and blend with surrounding surface. Should air pockets appear while sanding, puncture and fill with catalyzed resin. A hypodermic needle may be used to fill cavities. Let cure and resand.
- o. Mix catalyzed resin and work into patch with fingers. Smooth carefully and work into any crevices.
- p. Cover with cellophane and squeegee smooth. Allow to cure completely before removing cellophane. Let cure and resand.
- q. Brush or spray a coat of catalyzed resin to seal patch. Sand patch, finish by priming, again sanding and applying color coat.

NOTE

Brush and hands may be cleaned in solvents such as acetone or methylethylketone. If solvents are not available, a strong solution of detergent and water may be used.

*** CHEROKEE ARROW III SERVICE MANUAL**

4-59.THERMOPLASTIC REPAIRS. Refer to Borg-Warner manual part number PB-160A for repairs to thermoplastic.

Borg-Warner Chemicals
Washington, West Virginia 26181

4-60.SAFETY WALK REPAIR.

4-61.SURFACE PREPARATION.

- a. Clean all surfaces with a suitable cleaning solvent to remove dirt, grease and oils. Solvents may be applied by dipping, spraying or mopping.
- b. Insure that no moisture remains on the surface by wiping with a clean dry cloth.
- c. Outline the area to which the liquid safety walk compound is to be applied, and mask adjacent surfaces.

NOTE

Newly painted surfaces, shall be allowed to dry for 2.5 hours minimum prior to the application of the safety walk.

4-62.PRODUCT LISTING FOR LIQUID SAFETY WALK COMPOUND.

- a. Suggested Solvents:
 - Safety Solvent per MIL-S-18718
 - Sherwin Williams Lacquer Thinner R7KC120
 - Glidden Thinner No. 207
- b. Safety Walk Material:
 - Walkway Compound and Matting, Nonslip (included in Piper Part No. 179 872)

4-63.APPLICATION OF LIQUID SAFETY WALK COMPOUND. Liquid safety walk compound shall be applied in an area free of moisture for a period of 24 hours minimum after application. Do not apply when surface to be coated is below 50°F. Apply liquid safety walk compound as follows:

- a. Mix and thin the liquid safety walk compound in accordance with the manufacturer's instructions on the container.
- b. Coat the specified surfaces with a smooth, unbroken film of the liquid safety walk compound. A nap type roller or a stiff bristle brush is recommended, using fore and aft strokes.
- c. Allow the coating to dry for 15 minutes to one hour before recoating or touch-up; if required after application of the initial coating.
- d. After recoating or touch-up; if done, allow the coating to dry for 15 minutes to one hour before removing masking.

NOTE

The coated surface shall not be walked on for six hours minimum after application of final coating.

4-64. CONTROL SURFACE BALANCING.

4-65. CHECKING CONTROL SURFACE BALANCE. The movable control surfaces have been statically balanced at the time of installation at the factory and normally should not require rebalancing. Where possible the control surfaces where set with the balance weight on the heavy side of the limits, to permit limited repair or paint touch-up without adjusting the balance weight. It should be noted however, that spar control surfaces are delivered unpainted and the static balance will not necessarily fall within the limits provided, this is more pronounced on the stabilators and rudders. The completed control surface, including paint, should be within the limits given in Table IV-I. If the surface is not to be painted, the balance weight will probably require adjustment. All replacement control surfaces, or surfaces that have been repainted or repaired, should be rebalanced according to the procedures given in Paragraphs 4-65 thru 4-70. The static balance of the surfaces must be as specified in Table IV-I.

Before balancing any control surface, it must be complete including tip, trim/servo tabs and tab actuating arms or push rods with bearings as applicable, and all optional equipment which is mounted on or in the control surface when it is flown, including paint, position lights and wiring, static wicks, scuff boots, etc.

If optional equipment is added or removed after balancing, the control surface must be rebalanced. During balancing, trim/servo tabs must be maintained in their neutral positions.

4-66. CHECKING CONTROL SURFACES FREE PLAY. The following checks are recommended before balancing to ascertain the amount of “free play” in the stabilator, stabilator trim tab and aileron:

- a. Stabilator: Check the stabilator for any “free play” at its attachment points by grasping each half near the tip and gently trying to move it up and down, fore and aft, and in and out. No play is allowed.
- b. Stabilator Trim Tab: Set the stabilator trim tab in neutral position. This neutral position is determined with the airplane properly rigged per instructions given in Section V of this Service Manual and the trim indicator at its neutral position. Obtain a straightedge long enough to extend from the ground up to a few inches above the trim tab trailing edge. Place the straightedge next to the trim tab inboard (center) trailing edge, secure the stabilator in neutral and grasping the tab, gently move it up and down, mark the limit of tab free play on the straightedge. The overall travel (free play) must not exceed 0.15 of an inch. The use of a dial indicator and fixed stand is recommended.
- c. Aileron: Set the aileron in its neutral position and secure. Obtain a straightedge long enough to extend from the ground up to a few inches above the aileron trailing edge. Place the straightedge next to the aileron trailing edge and gently move the aileron up and down, mark the limit of travel (free play) on the straightedge. The overall travel (free play) must not exceed 0.24 of an inch. Should free play exceed the limit stated make necessary repairs as required to eliminate excessive free play.

* CHEROKEE ARROW III SERVICE MANUAL

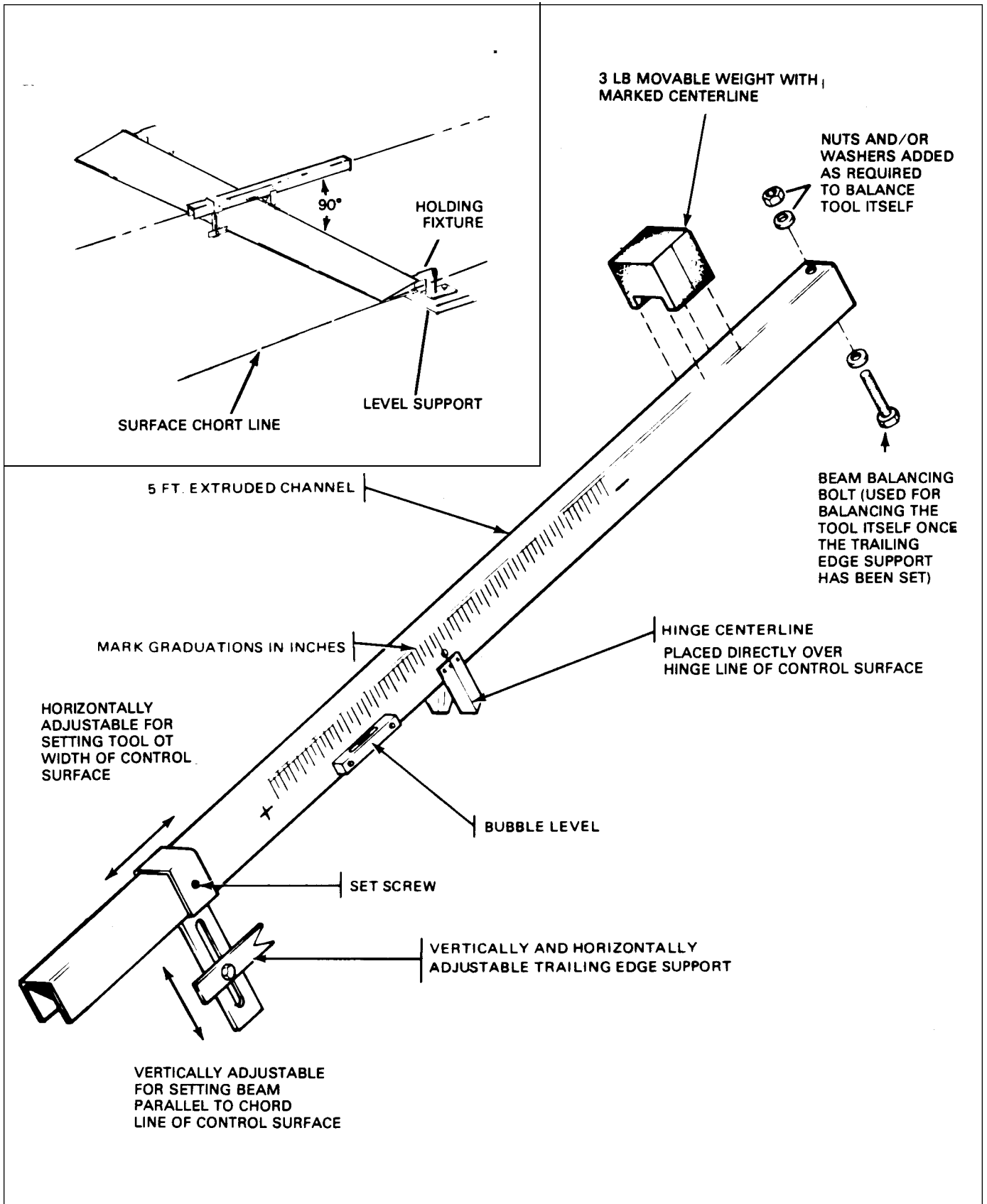

Figure 4-9. Control Surface Balance Tool

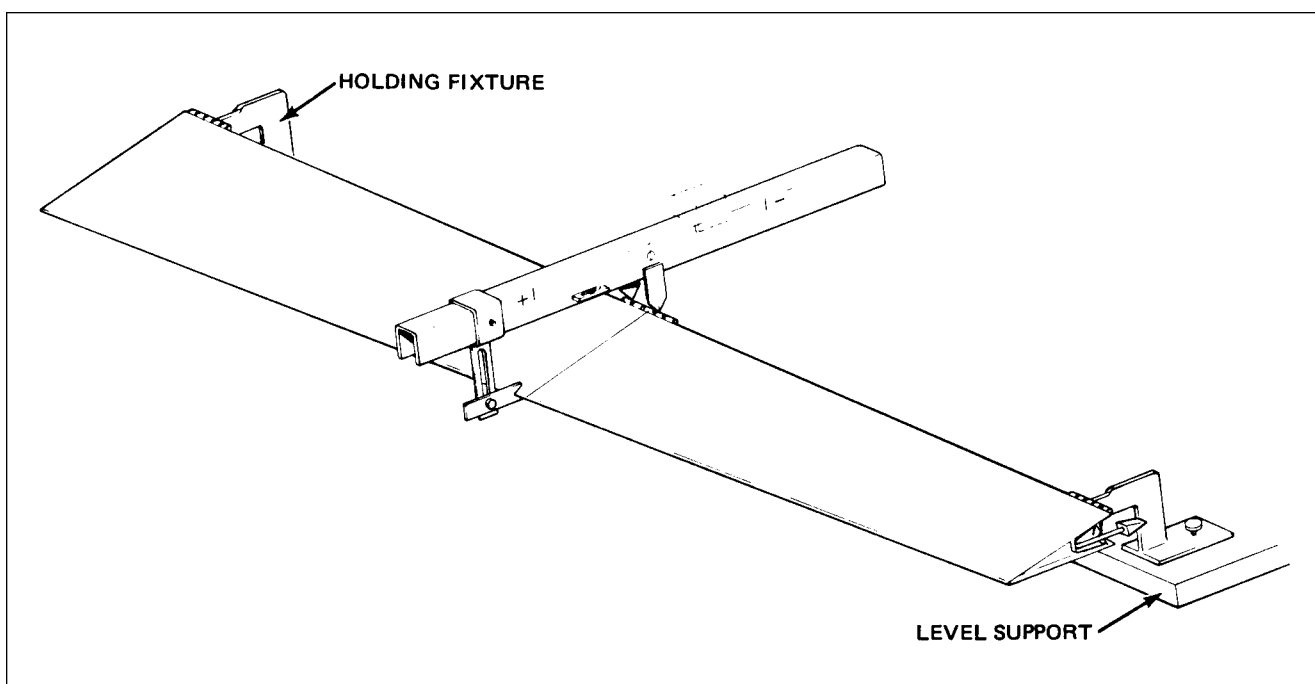

Figure 4-10. Aileron Balancing

4-67. **BALANCING EQUIPMENT.** (Refer to Figure 4-9.) The balancing must be done using a suitable tool capable of measuring unbalance in inch-pounds from the centerline of the control surface hinge pin. A suggested tool configuration is shown in Figure 4-9. Other tool configurations may be used, provided accuracy is maintained and recalibration capability is provided. The tool shown in Figure 4-9 may be calibrated by placing it on the control surface to be balanced with the balance points over the control surface hinge centerline and the balance bar parallel to the cord line. Position the trailing edge support to align the tool with the control surface cord line and secure in this position. Remove the tool without disturbing the trailing edge support and balance the tool by adding weight to the light end as required. (The movable weight must be at the centerline.) Place the tool on the control surface perpendicular to the hinge centerline as shown in Figures 4-10, 4-11 and 4-13. Read the scale when the bubble level has been centered by adjustment of the movable weight.

4-68. **BALANCING AILERONS.** (Refer to Figure 4-10.) Position the aileron on the balancing fixture in a draft free area and in a manner which allows unrestricted movement of the aileron on the hinges. Place the tool on the aileron, avoid rivets and keep the beam perpendicular to the hinge centerline. Calibrate the tool as described in Paragraph 4-67. Read the scale when the bubble level has been centered by adjustment of the movable weight and determine the static balance. If the static balance is not within the limits specified in Table IV-I, proceed as follows:

- a. **Leading Edge Heavy:** This condition is highly improbable; recheck measurements and calculations.
- b. **Trailing Edge Heavy:** There are no provisions for adding weight to balance weight to counteract a trailing edge heavy condition; therefore, it will be necessary to determine the exact cause of the unbalance. If the aileron is too heavy because of painting over old paint, it will be necessary to strip all paint from the aileron and repaint. If the aileron is too heavy resulting from repair to the skin or ribs, it will be necessary to replace all damaged parts and recheck the balance.

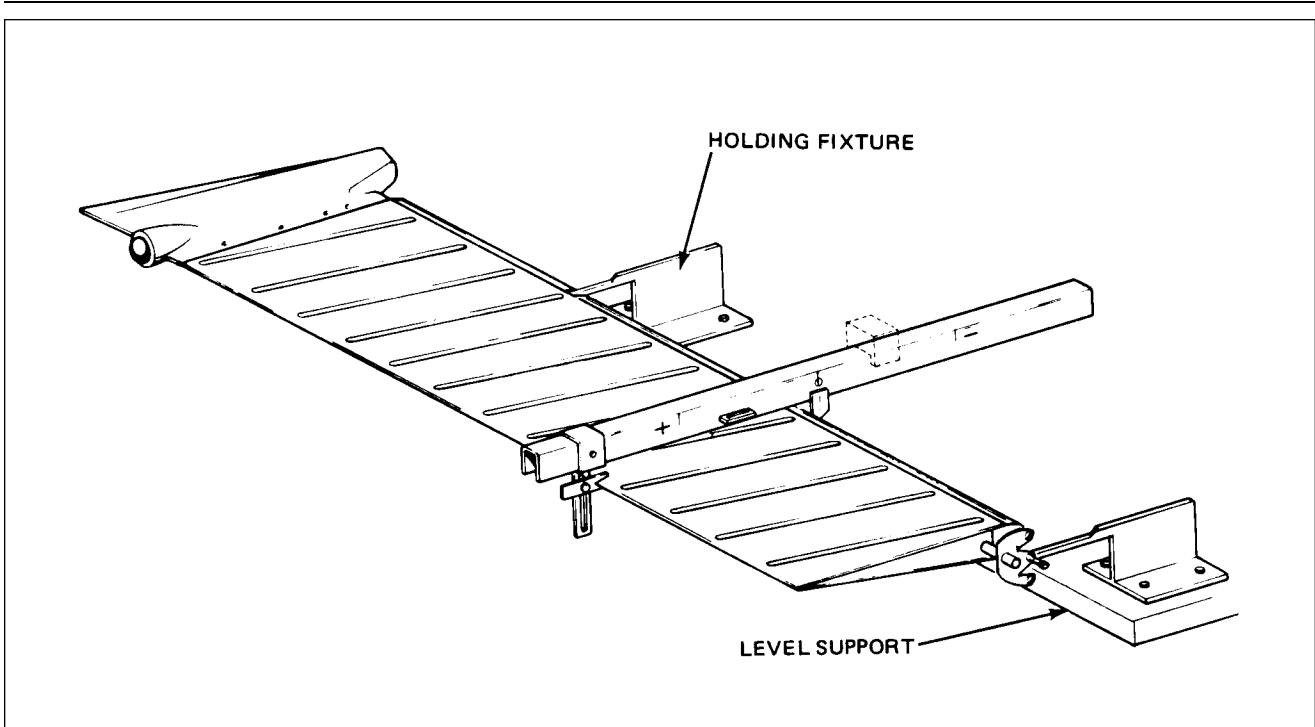

Figure 4-11. Rudder Balancing

4-69. BALANCING RUDDER. (Refer to Figure 4-11.) To balance the rudder, the assembly must be complete including the tip assembly and all attaching screws, the position light and wiring must be included. Place the complete assembly horizontally on knife edge supports in a draft free area in a manner that allows unrestricted movement. Place the tool on the rudder with the beam perpendicular to the hinge centerline. Calibrate the tool as described in Paragraph 4-67. Read the scale when the bubble level has been centered by adjustment of the movable weight and determine the static balance limit. If the static balance is not within the limits given in Table IV-I, proceed as follows:

- a. Nose Heavy: This condition is highly improbable; recheck calculations and measurements.
- b. Nose Light: In this case, the mass balance weight is too light or the rudder is too heavy because of painting; it will be necessary to strip the paint and repaint. If the rudder is too heavy as a result of repairs, the repair must be removed and the damaged parts replaced.

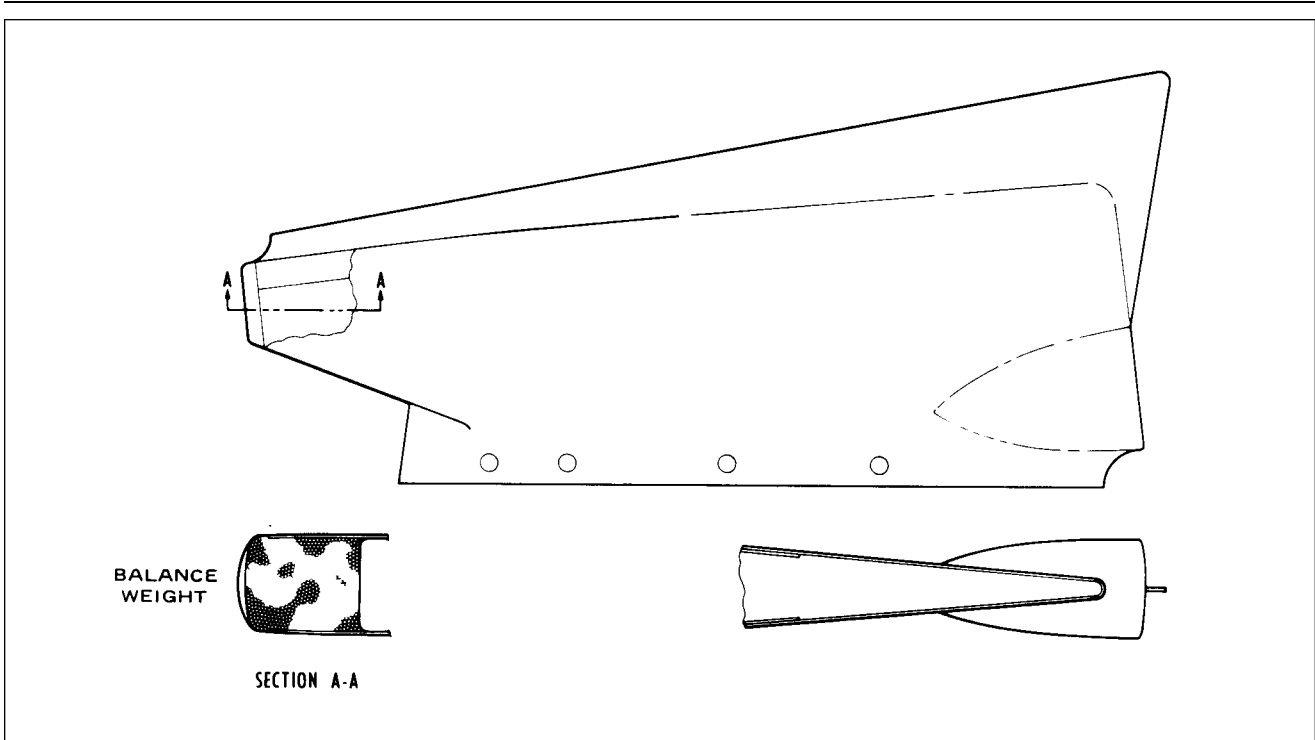

Figure 4-12. Rudder Balance Weight

TABLE IV-I. BALANCE SPECIFICATIONS

SURFACE	FLIGHT CONDITIONS STATIC BALANCE LIMITS (IN.—LBS.)	
	Leading Edge Heavy	Trailing Edge Heavy
Ailerons	-5	to -13
Stabilators	+5	to -40
Rudders	0	to -10.5

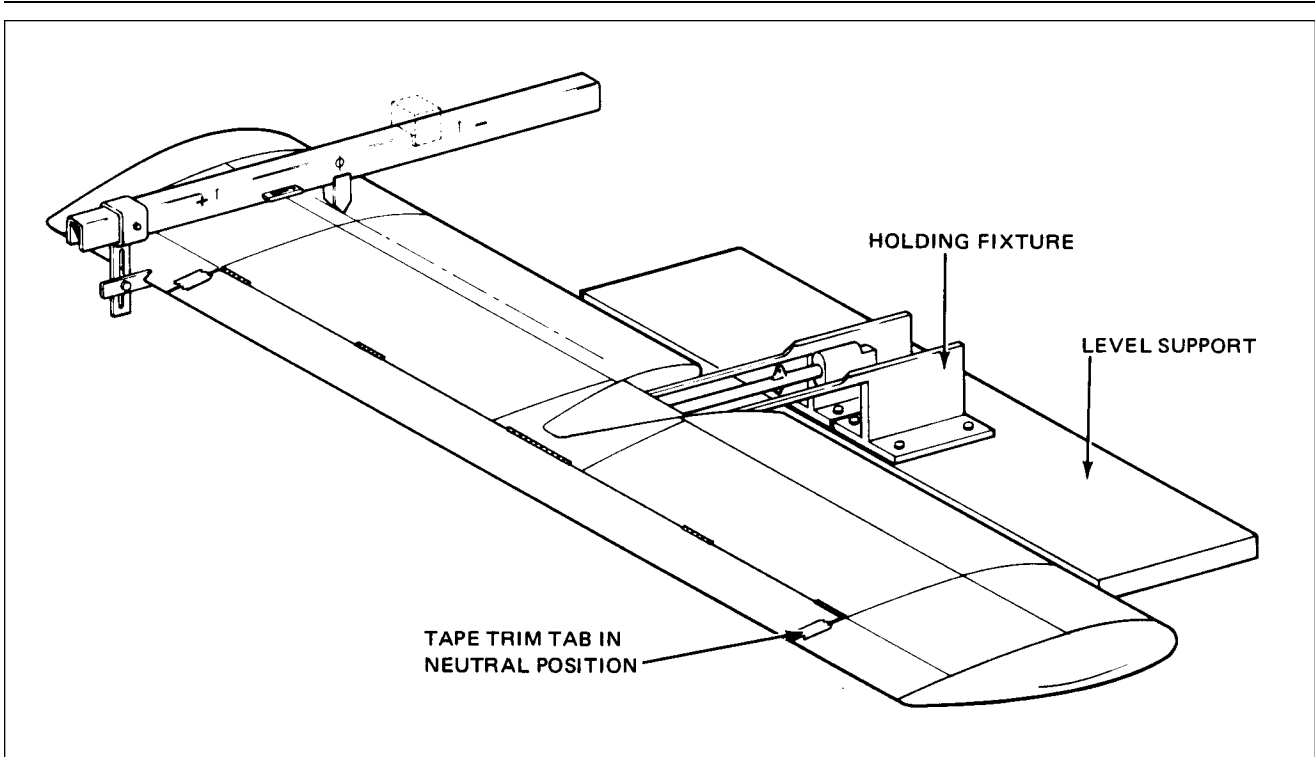

Figure 4-13. Stabilator Balancing.

4-70. BALANCING STABILATOR. (Refer to Figure 4-13.) To balance the stabilator, the assembly must be complete including the trim tab, the tab push rod and end bearing, stabilator tips and all attaching screws. Before balancing, tape the trim tab in neutral position with a small piece of tape. Place the complete assembly on the knife edge supports in a draft free beam perpendicular to the hinge centerline. Do not place the tool on the trim tab. Calibrate the tool as described in Paragraph 4-67. Read the scale when the bubble level has been centered by adjustment of the movable weight and determine the static balance limit. If the static balance is not within the limits given in Table IV-I, proceed as follows:

- a. If the stabilator is out of limits on the leading edge heavy side, remove balance plates from the mass balance weight until the static balance is within limits.
- b. If the stabilator is out of limits on the trailing edge heavy side, add balance plates to the mass balance weight until the static balance is within limits.

*** CHEROKEE ARROW III SERVICE MANUAL**

TABLE IV-II

MAXIMUM DISTANCE BETWEEN SUPPORTS FOR FLUID TUBING

TUBE OD (IN.)	DISTANCE BETWEEN SUPPORTS (IN.)	
	ALUMINUM ALLOY	STEEL
1/8	9-1/2	11-1/2
3/16	12	14
1/4	13-1/2	16
5/16	15	18
3/8	16-1/2	20
1/2	19	23
5/8	22	25-1/2
3/4	24	27-1/2
1	26-1/2	30

TABLE IV-III. Hose clamp tightening,
(initial installation).

Types of hose	Types of clamps	
	Worm screw type	All other types
Self sealing	Finger-tight-plus 2 complete turns	Finger-tight-plus 2 1/2 complete turns
All other hose	Finger-tight-plus 1 1/4 complete turns	Finger-tight-plus 2 complete turns
If clamps do not seal at specified tightening, examine hose connection and replace parts as necessary.		

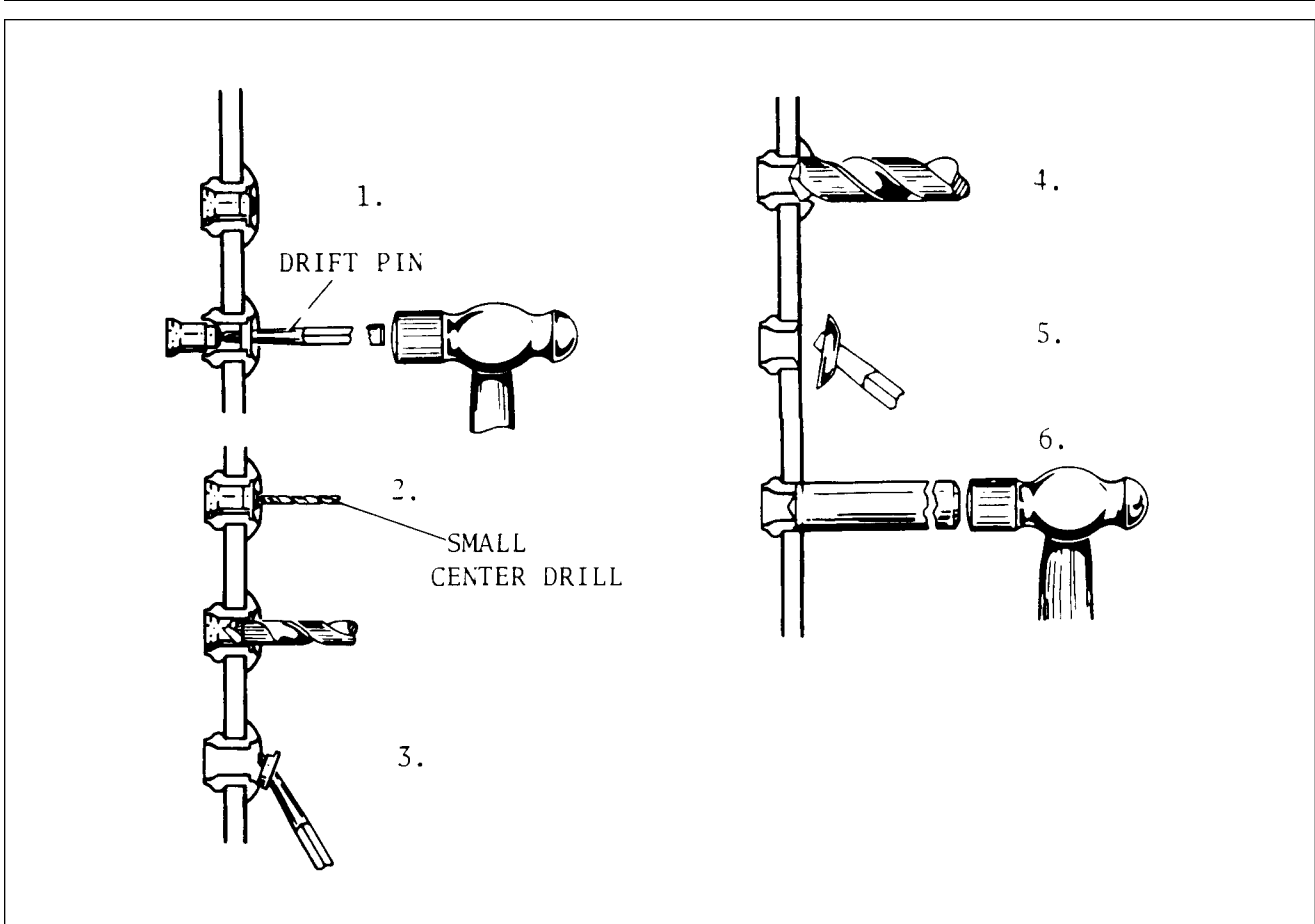

Figure 4-14. Removal of Cherrylock Rivet

4-71. REMOVAL OF CHERRYLOCK RIVETS. Should it be necessary to remove an installed cherrylock rivet, the following procedures are recommended.

- a. In thick material remove the lock by driving out the rivet stem, using a tapered steel drift pin (See View 1.)

NOTE

Do not drill completely through the rivet sleeve to remove a rivet as this will tend to enlarge the hole.

- b. If the rivets have been installed in thin sheets, driving out the locked stem may damage the sheets. It is recommended that a small center drill be used to provide a guide for a larger drill on top of the rivet stem, and the tapered portion of the stem be drilled away to destroy the lock. (See Views 2 and 3).
- c. Pry the remainder of the locking collar out of the rivet head with the drift pin (See View 3).
- d. Drill nearly through the head of the rivet, using a drill the same size as the rivet shank. (See View 4).
- e. Break off rivet head, using a drift pin as a pry (See View 5).
- f. Drive out the remaining rivet shank with a pin having a diameter equal to the rivet shank. (See View 6).

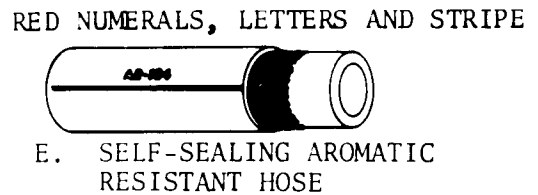
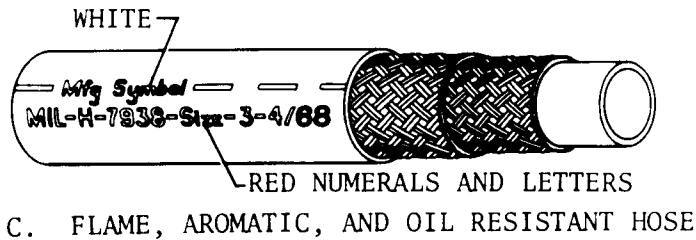
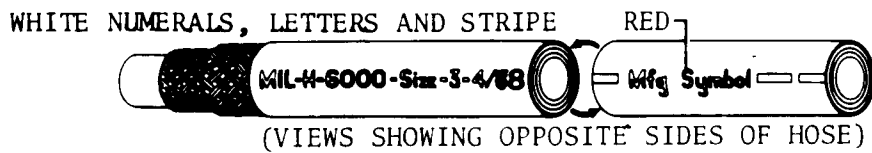
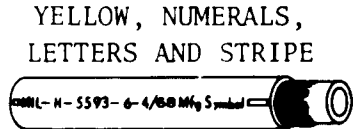
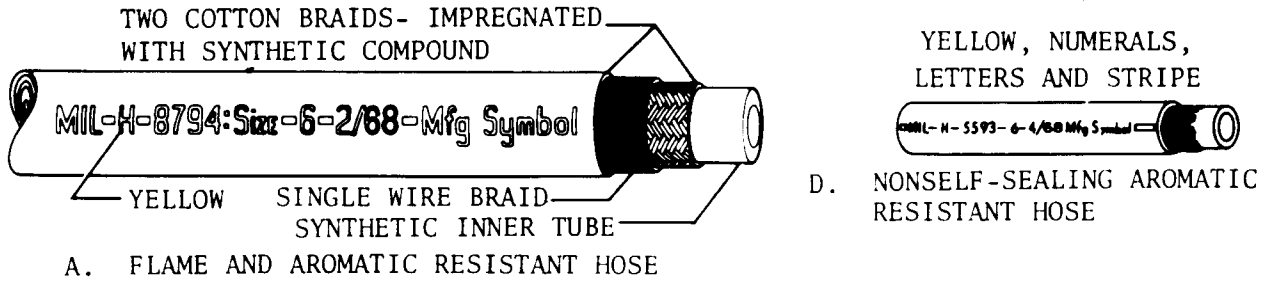

HOSE IDENTIFICATION MARKINGS

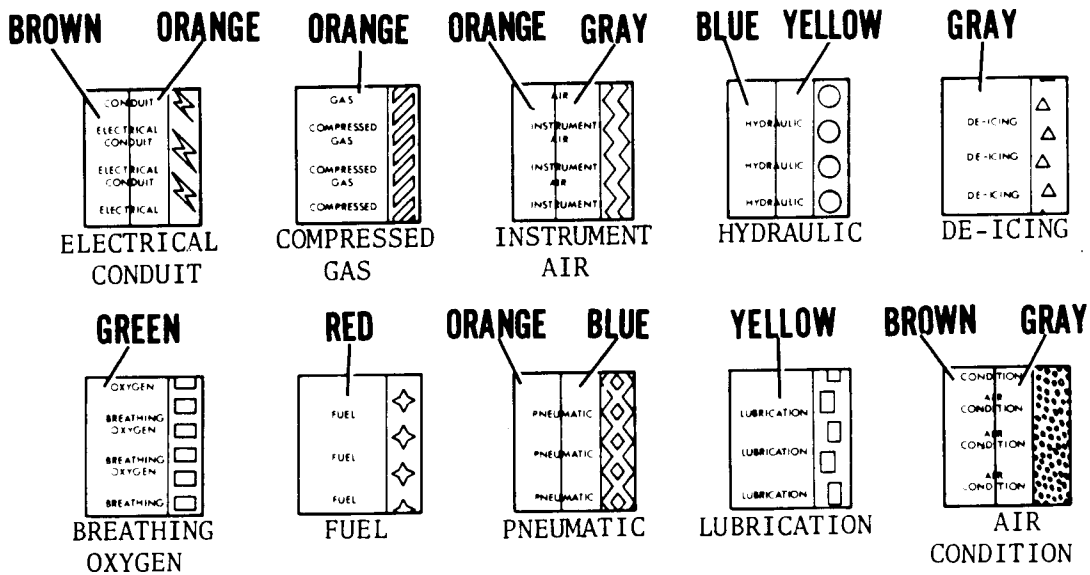

Figure 4-15. Identification of Aircraft Fluid Lines

4-72.STANDARDS.

4-73 TORQUE WRENCHES Torque wrenches should be checked daily and calibrated by means of weights and a measured lever arm to make sure that inaccuracies are not present. Checking one torque wrench against another is not sufficient and is not recommended. Some wrenches are quite sensitive as to the way they are supported during a tightening operation. Any instructions furnished by the manufacturer must be followed explicitly

When it is necessary to use a special extension or adapter wrench with a torque wrench, a simple mathematical equation must be worked out to arrive at the correct torque reading. Following is the formula to be used: (Refer to Figure 4-16.)

T = Torque desired at the part

A = Basic lever length from center of wrench shank to center of handle or stamped on wrench or listed for that model wrench.

B = Length of adapter extension center of bolt to center of shank.

C = Scale reading needed to obtain desired torque (T).

$$\text{The formula } C = \frac{A + T}{A + B}$$

EXAMPLE

A bolt requires 30 foot-pounds and a 3 inch adapter(one-quarter of a foot or .25') is needed to get at it. You want to know what scale reading it will take on a one-foot lever arm wrench to obtain the 30 foot-pounds at the bolt.

$$C = \frac{1 \times 30}{1 + .25} \quad \text{or} \quad C = \frac{30}{1.25} = 24 \text{ ft.-lbs.}$$

Remember the 3 inch adapter must be projecting 3 inches straight along the wrench axis. In general, avoid all complex assemblages or adapters and extensions of flex joints.

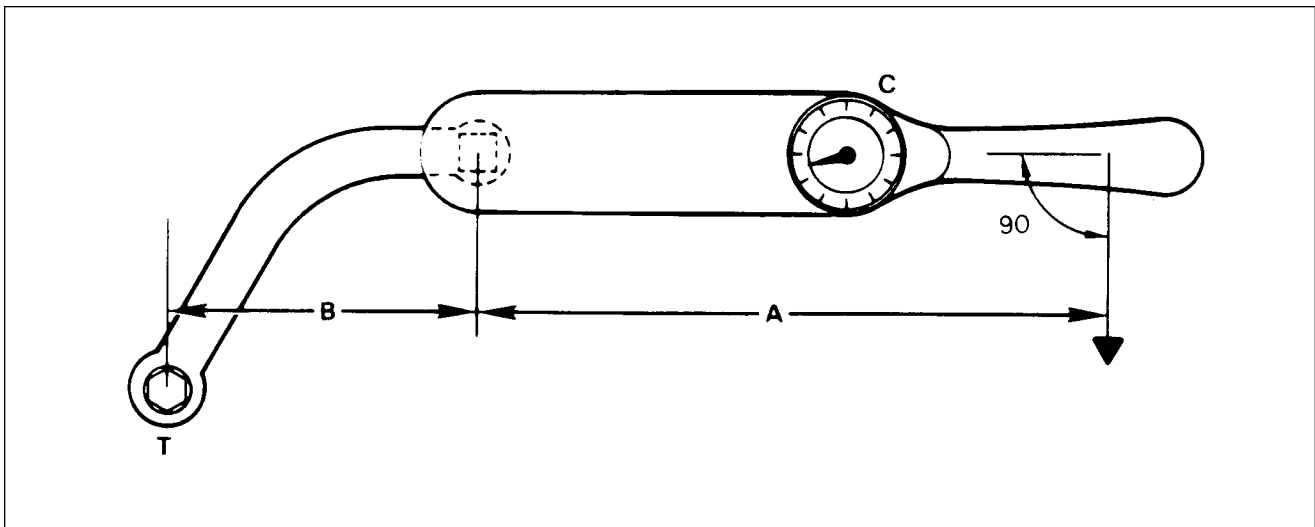

Figure 4-16. Torque Wrench Formula

SECTION V

SURFACE CONTROLS

Paragraph	Aerofiche Grid No.
5-1. Introduction	1F7
5-2. Description	1F7
5-3. Standard Procedures.....	1F7
5-4. Control Column Assembly.....	1F13
5-5. Removal of Control Column Assembly.....	1F13
5-6. Installation of Control Column Assembly.....	1F14
5-7. Aileron Controls.....	1F16
5-8. Removal of Aileron Control Cables.....	1F16
5-9. Installation of Aileron Control Cables	1F17
5-10. Removal of Aileron Bellcrank Assembly.....	1F17
5-11. Installation of Aileron Bellcrank Assembly.....	1F18
5-12. Rigging and Adjustment of Aileron Controls	1F19
5-13. Stabilator Controls.....	1F21
5-14. Removal of Stabilator Control Cables.....	1F21
5-15. Installation of Stabilator Control Cables.....	1F21
5-16. Rigging and Adjustment of Stabilator Control.....	1F23
5-17. Stabilator Trim Control.....	1F24
5-18. Removal of Stabilator Trim Assembly (Forward).....	1F24
5-19. Installation of Stabilator Trim Assembly (Forward).....	1G1
5-20. Removal of Stabilator Trim Assembly (Aft).....	1G2
5-21. Installation of Stabilator Trim Assembly (Aft)	1G2
5-22. Rigging and Adjustment of Stabilator Trim.....	1G4
5-23. Rudder and Steering Pedal Assembly	1G4
5-24. Removal of Rudder and Steering Pedal Assembly.....	1G4
5-25. Installation of Rudder and Steering Pedal Assembly.....	1G6
5-26. Rudder Controls.....	1G8
5-27. Removal of Rudder Control Cables	1G8
5-28. Installation of Rudder Control Cables.....	1G9
5-29. Rigging and Adjustment of Rudder Controls.....	1G9
5-30. Rudder Trim Controls.....	1G10
5-31. Removal of Rudder Trim Controls.....	1G10
5-32. Installation of Rudder Trim Controls	1G10
5-33. Rigging and Adjustment of Rudder Trim Controls.....	1G11
5-34. Wing Flap Controls.....	1G11
5-35. Removal of Wing Flap Controls.....	1G11
5-36. Installation of Wing Flap Controls.....	1G12
5-37. Rigging and Adjustment of Wing Flaps.....	1G15

SECTION V

SURFACE CONTROLS

5-1. INTRODUCTION. This section contains the explanation for the removal, installation, rigging and adjustment procedures for the control assemblies of the various structural surfaces. For the removal and installation of the structural surfaces of the airplane, refer to Section IV. The assemblies need not be removed in order of paragraphs since each paragraph describes the individual removal and installation of the component.

5-2. DESCRIPTION. The airplane is controlled in flight by the use of three standard primary control surfaces, consisting of the ailerons, stabilator and rudder. Operation of these controls is through the movement of the dual control columns and dual rudder pedals. The individual surfaces are connected to their control components through the use of cables and push-pull tubes. Provision for directional and longitudinal trim control is provided by an adjustable trim mechanism for the rudder and stabilator. The flaps are mechanically operated and can be positioned in four locations of 0, 10, 25 and 40 degrees.

The aileron controls consist of two-control wheels connected by torque tubes to sprockets on each end of the horizontal control column. A chain is wrapped around the sprockets and around a double sprocket on the vertical post of the control column. The chain is connected to the primary aileron control cable which is routed through the center of the fuselage to the main spar and out through the wings to a bellcrank in each wing. A balance cable is also connected to the bellcrank. As the control wheels are moved, the control cables move the bellcranks and actuate push-pull rods to move the ailerons.

The stabilator controls are also connected to the control column. From the connecting point, cables are routed around a series of pulleys down under the floor and aft to the tail section of the airplane. The aft end of the cables connect to the stabilator balance arm which in turn is connected to the stabilator. When the control wheels are moved forward or aft, the cables move the balance arm up and down rotating the stabilator on its hinge points.

The rudder is controlled by the pilot's and co-pilot's rudder pedals. Cables are connected to both sides of the rudder pedal assembly and are routed aft through the bottom of the fuselage to the rudder horn. When one rudder pedal is pushed, the cables move in opposite directions turning the rudder horn and rudder. The wing flap system is operated by a lever located between the front seats.

For a visual description of the various control systems, refer to the illustrated figures throughout this section.

5-3. STANDARD PROCEDURES. The following tips may be helpful in the removal, installation and rigging of the various assemblies:

- a. It is recommended, though not always necessary to level and place the airplane on jacks during rigging and adjustment.
- b. Remove turnbuckle barrels from cable ends before withdrawing the cables through the structures.
- c. Tie a cord to the cable end before withdrawing the cable through the structures to facilitate reinstallation of cable.
- d. Turnbuckle stations are given at their neutral positions.
- e. When referring to marking cable end, etc., before disconnecting a felt marking pen may be used.
- f. Assemble and adjust the turnbuckles so that each terminal is screwed an approximately equal distance into the barrel. Do not turn the terminals in such a manner that will put a permanent "twist" into the cables.
- g. Cable tensions should be taken with the appropriate control surface in its neutral position.

*** CHEROKEE ARROW III SERVICE MANUAL**

TABLE V-I CONTROL SURFACE TRAVEL AND CABLE TENSION

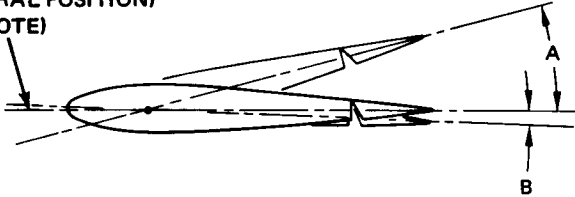
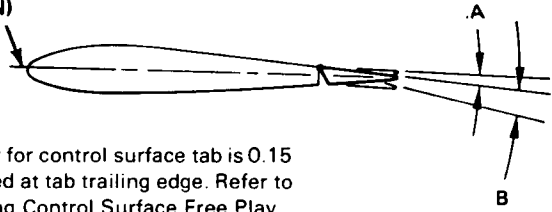
<p align="center">Stabilator</p> <p>A - STABILATOR TRAILING EDGE UP TRAVEL FROM NEUTRAL $16^{\circ} \pm 1^{\circ}$</p> <p>B - STABILATOR TRAILING EDGE DOWN TRAVEL FROM NEUTRAL $2^{\circ} \pm 1^{\circ}$</p>	<p>STABILATOR CHORD LINE (NEUTRAL POSITION) (SEE NOTE)</p>  <p>Neutral position of stabilator is with the stabilator chord line parallel with the top of the front seat tracks.</p>
<p align="center">Stabilator Trim Tab</p> <p>A - STABILATOR TAB TRAILING EDGE UP TRAVEL FROM NEUTRAL $3^{\circ} \pm 1^{\circ}$</p> <p>B - STABILATOR TAB TRAILING EDGE DOWN TRAVEL FROM NEUTRAL $12^{\circ} \pm 1^{\circ}$</p>	<p>STABILATOR CHORD LINE (NEUTRAL POSITION) (SEE NOTE 2)</p>  <ol style="list-style-type: none"> Maximum free play for control surface tab is 0.15 of an inch measured at tab trailing edge. Refer to Section IV. Checking Control Surface Free Play. Neutral position of stabilator is with the stabilator chord line parallel with the top of the front seat tracks.
<p align="center">Rudder Pedal Neutral Angle</p> <p align="center">AFT VERTICAL TO SEAT RAILS.</p>	<p align="center">$14^{\circ} + 3^{\circ} - 1^{\circ}$</p>
<p align="center">Cable Tensions</p> <p>AILERON FLAP STABILATOR STABILATOR TRIM TAB RUDDER</p>	<p>40 lbs. +/- 5 lbs. 10 lbs. +/- 1 lb. 40 lbs. +/- 5 lbs. 14 lbs. +/- 1 lb. 35 lbs. +/- 5 lbs.</p>
<p align="center">NOTE</p> <p>CABLE TENSIONS GIVEN APPLY ONLY TO AIRPLANES WITHOUT AUTOPILOT BRIDLE CABLES ATTACHED. REFER TO APPROPRIATE AUTOPILOT SERVICE MANUAL FOR PROPER CABLE TENSIONS WHEN ATTACHING BRIDLE CABLES.</p> <p>CABLE RIGGING TENSIONS SPECIFIED MUST BE CORRECTED TO AMBIENT TEMPERATURE IN THE AREA WHERE THE TENSION IS BEING CHECKED USING TABLE V-II.</p>	

*** CHEROKEE ARROW III SERVICE MANUAL**

TABLE V-I CONTROL SURFACE TRAVEL AND CABLE TENSION (cont.)

<p align="center">Aileron</p> <p>A - $25^{\circ} \pm 2^{\circ}$ UP</p> <p>B - $12.5^{\circ} \pm 2^{\circ}$ DOWN</p>	<p align="right">AILERON IN NEUTRAL POSITION ALIGNED WITH FLAPS</p>  <ol style="list-style-type: none"> 1. Flap Adjustment must be complete before starting aileron adjustment. 2. Maximum free play for aileron is 0.24 of an inch, measured at trailing edge. Refer to Section IV, Paragraph 4-61.
<p align="center">Rudder</p> <p>A - $28^{\circ} \pm 1^{\circ}$ LEFT</p> <p>B - $28^{\circ} \pm 1^{\circ}$ RIGHT</p>	
<p align="center">Flap</p> <p>A - $10^{\circ} \pm 2^{\circ}$ FIRST NOTCH TRAVEL</p> <p>B - $25^{\circ} \pm 2^{\circ}$ SECOND NOTCH TRAVEL</p> <p>C - $40^{\circ} \pm 2^{\circ}$ THIRD NOTCH TRAVEL</p>	<p align="right">FLAP IN NEUTRAL POSITION WITH RIGGING TOOL INSTALLED PER PARAGRAPH 5-37.</p> 

TABLE V-II. CABLE TENSION VS. AMBIENT TEMPERATURE



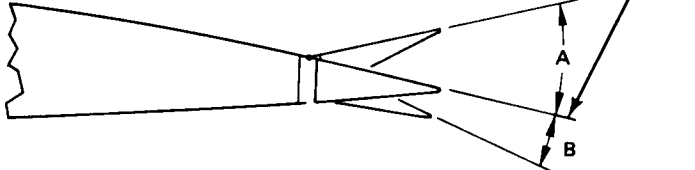
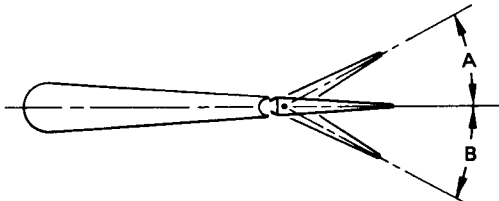
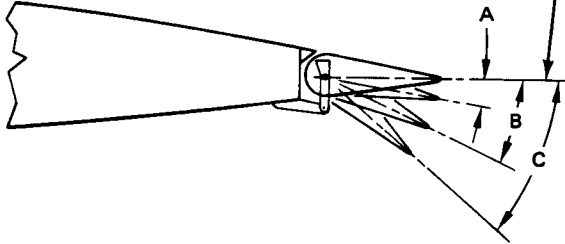
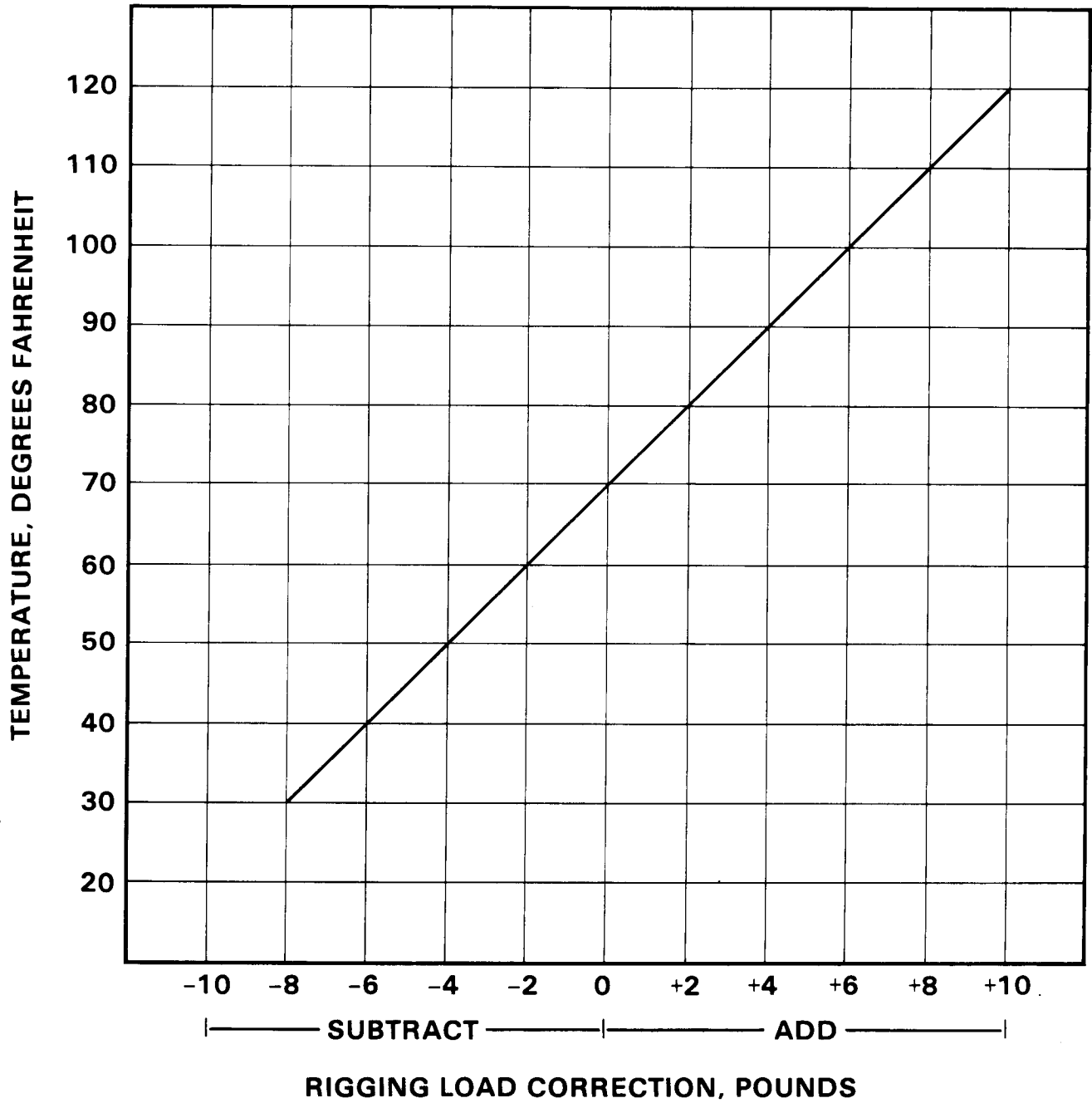
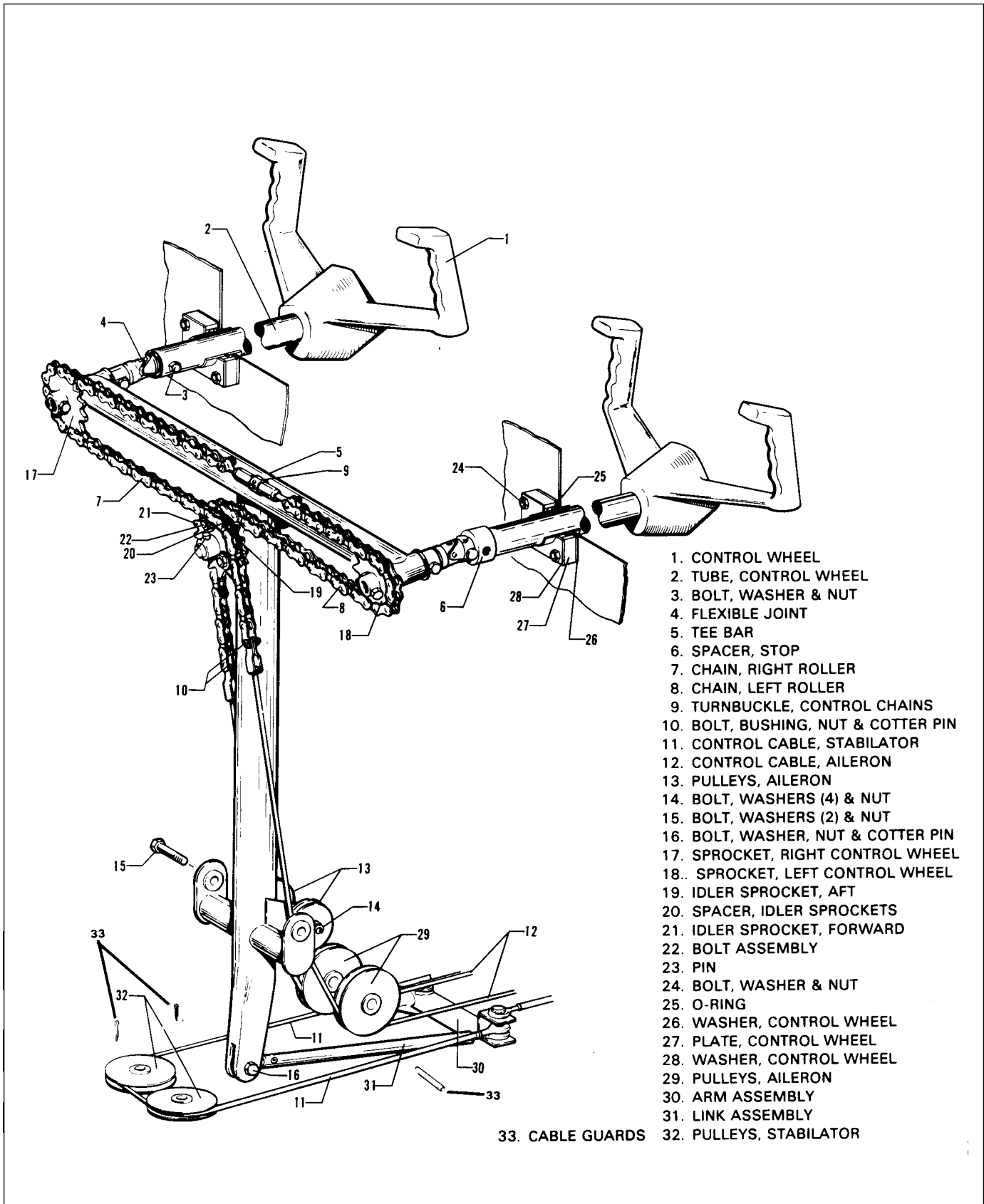

1. CONTROL WHEEL
2. TUBE, CONTROL WHEEL
3. BOLT, WASHER & NUT
4. FLEXIBLE JOINT
5. TEE BAR
6. SPACER, STOP
7. CHAIN, RIGHT ROLLER
8. CHAIN, LEFT ROLLER
9. TURNBUCKLE, CONTROL CHAINS
10. BOLT, BUSHING, NUT & COTTER PIN
11. CONTROL CABLE, STABILATOR
12. CONTROL CABLE, AILERON
13. PULLEYS, AILERON
14. BOLT, WASHERS (4) & NUT
15. BOLT, WASHERS (2) & NUT
16. BOLT, WASHER, NUT & COTTER PIN
17. SPROCKET, RIGHT CONTROL WHEEL
18. SPROCKET, LEFT CONTROL WHEEL
19. IDLER SPROCKET, AFT
20. SPACER, IDLER SPROCKETS
21. IDLER SPROCKET, FORWARD
22. BOLT ASSEMBLY
23. PIN
24. BOLT, WASHER & NUT
25. O-RING
26. WASHER, CONTROL WHEEL
27. PLATE, CONTROL WHEEL
28. WASHER, CONTROL WHEEL
29. PULLEYS, AILERON
30. ARM ASSEMBLY
31. LINK ASSEMBLY
32. PULLEYS, STABILATOR
33. CABLE GUARDS

Figure 5-1. Control Column Assembly

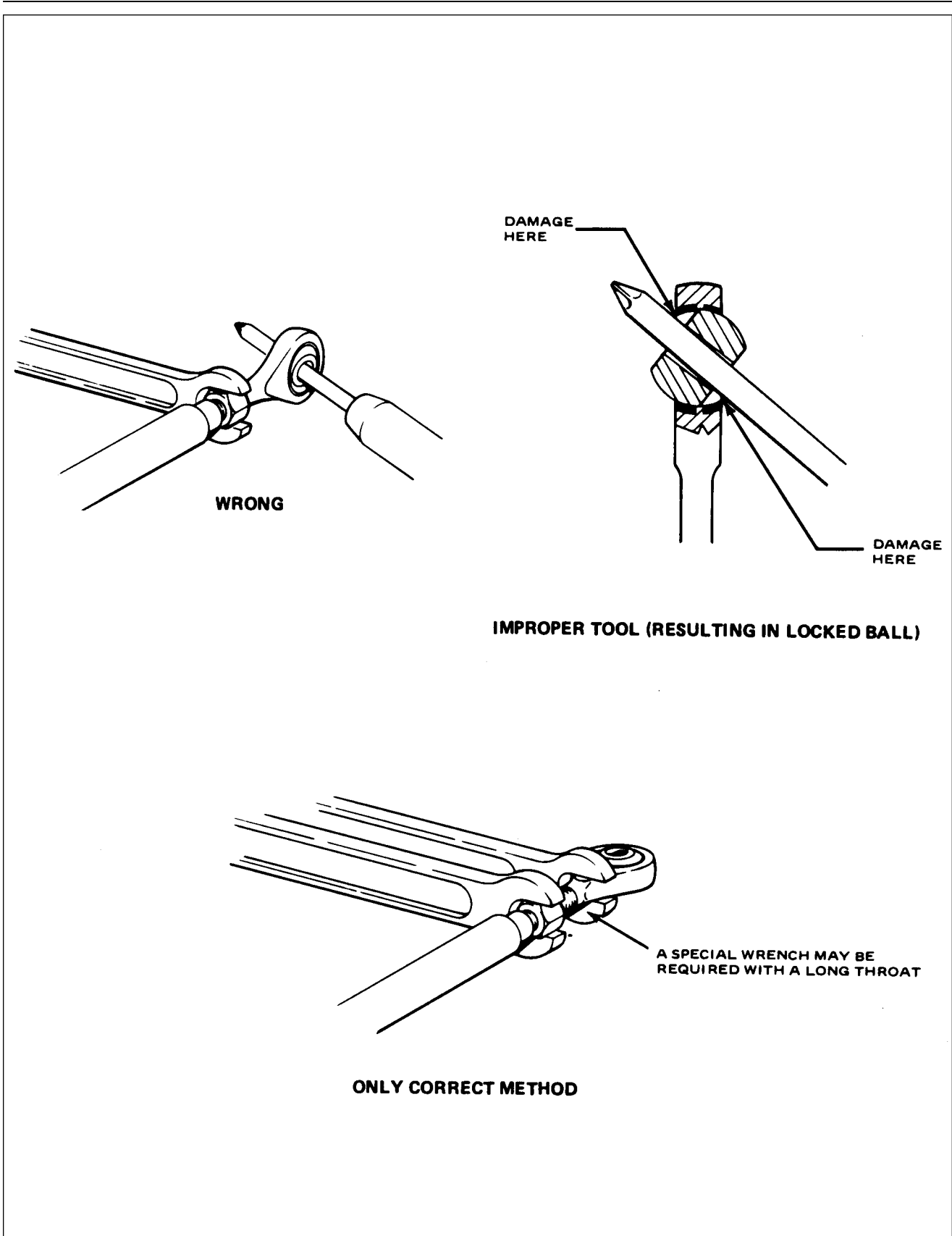

Figure 5-1a. Method of Installing Rod End Bearings

- h. After completion of each adjustment, check the turnbuckles to be sure not more than three terminal threads are visible outside the barrel. Install the locking clips, and check for proper installation by turning to remove the clips using fingers only. Both locking clips may be installed in opposite holes. Locking clips which have been installed and removed must be scrapped and not reused.
- i. When push rods or rod ends are provided with an inspection hole, the screw must be screwed in far enough to pass the inspection hole. This can be determined visually or by feel inserting a piece of wire into the inspection hole. If no hole is provided, there must be a minimum of .375 of an inch thread engagement.
- j. After completion of adjustments, each jam nut must be tightened securely. (Refer to Figure 5-1a for proper installation method).
- k. Torque all nuts in the flight control surface rigging system (including nose wheel steering) in accordance with Table II-II, Recommended Nut Torques.

NOTE

Cable rigging tensions specified must be corrected to ambient temperature in the area where the tension is being checked, using Table V-II.

5-4. CONTROL COLUMN ASSEMBLY.

5-5. REMOVAL OF CONTROL COLUMN ASSEMBLY. (Refer to Figure 5-1.)

- a. To remove either control wheel (1) with tube (2), the following procedure may be used:
 - 1. Separate the control wheel tube (2) from the flexible joint (4) that is located on either side of the tee bar assembly (5) by removing the nut, washer and bolt (3). Pull the tube from the flexible joint.
 - 2. If removing the left control tube, slide the stop (6) from the tube.
 - 3. Should wires for the various Autopilot systems be installed in the control tube, disconnect them at the quick disconnect terminals behind the instrument panel. Draw the wires back into the tube and out through the forward end of the tube.
 - 4. Remove the control wheel assembly from the instrument panel.
- b. The tee bar (5) with assembled parts may be removed from the airplane by the following procedure:
 - 1. Remove the access panel to the aft section of the fuselage.
 - 2. Relieve cable tension from the stabilator control cables (11) at one of the stabilator cable turnbuckles in the aft section of the fuselage.
 - 3. Relieve tension from the aileron control cables (12) and chains (7 and 8) and at the turnbuckle (9) that connects the chains at the top of the tee bar (5).
 - 4. Disconnect the control chains from the control cables where the chains and cables join by removing the cotter pins, nuts, bolts and bushings (10).
 - 5. Remove the tunnel cover by removing the rudder trim control knob and trim control knob and trim cover attaching screws. Roll back the carpet from the tunnel and remove the tunnel plate that is located just aft of the tee bar assembly, by removing the plate attaching screws.
 - 6. Remove the two aileron control cable pulleys (13) attached to the lower section of the tee bar by removing the pulley attaching bolt (14).
 - 7. Disconnect the stabilator controls (31) by removing the nut, bolt, washers and cotter pin (16) from the end of the tee bar assembly.
 - 8. Disconnect the necessary controls, such as the mixture control, throttle control, etc., that will allow the tee bar assembly to be removed.
 - 9. Remove the tee bar assembly by removing the attaching bolts (15) with washers and nuts, which are through each side of the floor tunnel, and lifting it up and out through the right side of the cabin.

5-6. INSTALLATION OF CONTROL COLUMN ASSEMBLY. (Refer to Figure 5-1.)

- a. The tee bar assembly may be installed in the airplane by the following procedure:
 1. Swing the tee bar assembly into place from the right side of the cabin and secure with attaching bolts (15), washers and nuts inserted in through each side of the floor tunnel.
 2. Place link assembly end (31) into the lower end of the tee bar assembly (5) and secure with bolts, washer, nut and cotter pin (16).
 3. Place the aileron control cables (12) around the pulleys (13) that attach to the lower section of the tee bar (5), position pulleys and secure with bolt, washers and nut (14).
 4. Install the control wheel per Step b.
 5. Place the control wheels in neutral (centered) position and install the aileron control chains (7 and 8) on the control wheel sprockets (17 and 18) and idler cross-over sprockets (19 and 21). This turnbuckle (9) must be centered between the two control wheel sprockets.
 6. Loosen the connecting bolts (22) of the idler sprockets (19 and 21) to allow the chain to fit snug around the control wheel sprockets and over the idler sprockets.
 7. Connect the aileron control cables (12) to the ends of the chains (7 and 8) with bolts, bushings, nuts and cotter pins (10).
 8. Adjust the chain turnbuckle (9) between the two control wheel sprockets to allow the control wheels to be neutral and obtain proper cable tension as given in Table V-I. It may be necessary, in order to have both control wheels neutral, to set the chain turnbuckle to neutralize the wheels and then set cable tension with the turnbuckles located under the floor panel aft of the main spar as instructed in Paragraph 5-12. Before safetying the turnbuckle, check that when the ailerons are neutral, the control wheels will be neutral and the chain turnbuckle centered. Also, the aileron bellcranks should contact their stops before the control wheel hits its stop. Maintain .030 to .040 clearance between sprocket pin and adjustable stop bolts on tee bar.
 9. Set stabilator cable tension with the turnbuckle in the aft section of the fuselage and instructions given in Paragraph 5-16. Check safety of all turnbuckles upon completion of adjustments.
 10. Tighten the connecting bolts (22) of the idler sprockets (19 and 21).
 11. Install the floor tunnel plate trim covers by placing the tunnel plate into position for installation and secure with the appropriate screws. Roll the carpet into place and install the rudder trim cover and knob.
- b. Either control wheel assembly may be installed by the following procedure:
 1. Insert the control wheel tube through the instrument panel.
 2. Should wires for the various Autopilot systems need to be installed in the control tube, route them through the hole in the forward side of the tube and out of the small hole in the forward side. Position the rudder grommet in the hole in the side of the tube.
 3. On the left control tube install the stop (6).
 4. Connect the control wheel tube (2) to the flexible joint (4) of the tee bar assembly. If the control cables and/or chains have not been removed or loosened, place the ailerons in neutral and install the control tube on the flexible joint to allow the control wheel to be neutral. Install bolt, washer and nut (3) and tighten.

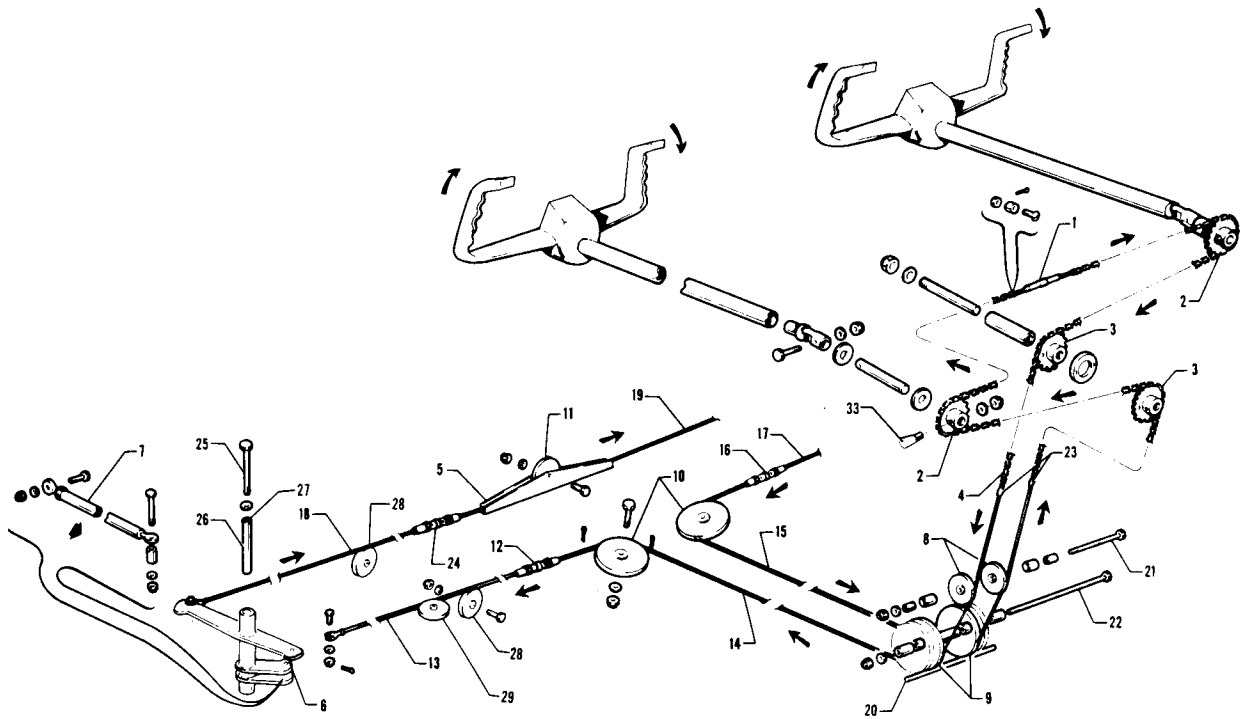

- | | |
|-----------------------------------|-------------------------------------|
| 1. TURNBUCKLE, CONTROL CHAINS | 17. CABLE, LEFT WING PRIMARY |
| 2. SPROCKET CONTROL WHEEL | 18. CABLE, RIGHT BALANCE |
| 3. SPROCKET, IDLER | 19. CALBE, LEFT BALANCE |
| 4. CHAIN, AILERON CONTROL | 20. ROD, CABLE GUARD |
| 5. BRACKET, PULLEY | 21. BOLT, WASHER & NUT |
| 6. BELLCRANK, AILERON | 22. BOLT, WASHER & NUT |
| 7. ROD, AILERON CONTROL | 23. BOLT, NUT, BUSHING & COTTER PIN |
| 8. PULLEY, TEE BAR | 24. TURNBUCKLE, BALANCE CABLE |
| 9. PULLEY, FORWARD CLUSTER | 25. BOLT, BELLCRANK PIVOT |
| 10. PULLEY, PRIMARY CONTROL CABLE | 26. BUSHING, BELLCRANK |
| 11. PULLEY, BALANCE CABLE | 27. TUBE, TEFLON |
| 12. TURNBUCKLE, RIGHT PRIMARY | 28. PULLEY, LEFT & RIGHT |
| 13. CABLE, RIGHT WING PRIMARY | 29. PULLEY |
| 14. CABLE, RIGHT FUSELAGE PRIMARY | 30. COTTER KEY CABLE GUARDS |
| 15. CABLE, LEFT FUSELAGE PRIMARY | 31. COTTER KEY CABLE GUARD |
| 16. TURNBUCKLE, LEFT PRIMARY | 32. COTTER KEY CABLE GUARD |
| | 33. TAPERED PIN |

Figure 5-2. Aileron Controls

5-7. AILERON CONTROLS.

5-8. REMOVAL OF AILERON CONTROL CABLES. (Refer to Figure 5-2.)

- a. For the removal of either the control cables in the fuselage or the wings, first remove the rear seat floor panel.
- b. To remove either the right or left primary control cables (14 or 15) that are located in the fuselage, the following procedure may be used:
 1. Remove the two front seats from the airplane.
 2. Remove the tunnel cover located aft of the tee bar assembly by removing the rudder trim control knob and trim cover attaching screws. Roll back the carpet from the tunnel and remove the tunnel plate that is located just aft of the tee bar assembly by removing the plate attaching screws.

NOTE

To help facilitate reinstallation of control cables, mark the cable ends and attach a line where applicable before drawing them through the fuselage or wing.

3. Separate the primary control cable (14 or 15) at the turnbuckle (12 or 16) located under the rear seat or floor panel aft of the main spar.
4. Remove the cable pulleys (8) attached to the lower-section of the control column tee bar assembly by removing the pulley attaching bolt (21).
5. Move the cable guard (20) under the pulley cluster (9) located just aft of the lower portion of the tee bar by removing the cotter pin from the exposed end of the guard and sliding it to the left or right as required.
6. Remove the cotter pins used as cable guards at the pulley (10) in the forward area of the floor opening aft of the main spar.
7. Disconnect the cable (14 or 15) from the control chain (4) at the control column tee bar assembly by removing the cotter pin, nut, bolt and bushing (23) that connect the two together. Secure the chains in some manner to prevent them from unwrapping from around the sprockets.
8. Draw the cable back through the floor tunnel.
- c. The primary control cable (13 or 17) in either wing may be removed by the following procedure:
 1. Remove the access plate to the aileron bellcrank (6) located on the underside of the wing forward of the inboard end of the aileron.
 2. If not previously disconnected, separate the cable at the turnbuckle (12 or 16) located in the area aft of the main spar.
 3. Disconnect the cable from the forward end of the aileron bellcrank by removing the cotter pin, nut, washer and bolt.
 4. Remove cable guard from pulley (28).
 5. Draw the cable from the wing.
- d. Either balance cable (18 or 19) may be removed by the following procedure:
 1. Separate the balance cable at the turnbuckle (24) in the right side of the opening aft of the main spar.
 2. If the left balance cable is to be removed, remove the cotter pin used as a cable guard at the pulley (11) in the center of the opening.
 3. Remove the access plate to the aileron bellcrank (6) located on the underside of the wing forward of the inboard end of the aileron.
 4. Disconnect the cable from the aft end of the aileron bellcrank by removing the cotter pin, nut, washer and bolt.
 5. Draw the cable from the wing.

NOTE

Examine cables for broken strands by wiping the cable along its length. Visually check for damage. Replace all damaged cables.

5-9. INSTALLATION OF AILERON CONTROL CABLES. (Refer to Figure 5-2.)

- a. The installation of either the right or left primary control cable (14 or 15) that is located in the fuselage may be accomplished as follows:
 1. Draw the cable through the fuselage floor tunnel.
 2. Connect the cable to the end of the control chain (4) and secure using bushings, bolt, nut and cotter pin (23).
 3. Place the cable around the pulley (9) that is located in the tunnel aft of the tee bar.
 4. Position cables and install the cable pulleys (8) that attach to the lower section of the tee bar assembly. Secure with bolt, washer and nut (21).
 5. Place the cable around the pulley (10) that is located within access opening just aft of the main spar.
 6. If the primary control cable in the wing is installed, connect the control cable ends at the turnbuckle (12 or 16) located within access opening just aft of the main spar. Apply partial tension to cable to keep it positioned on pulleys.
 7. Install cable guard (20) on pulley (9) and secure with a cotter pin.
 8. Install cotter pin cable guard on pulley (10).
 9. Check rigging and adjustment per Paragraph 5-12.
 10. Install the floor tunnel plate trim covers by placing the tunnel plate into position for installation and secure with attachment screws. Roll the carpet into place and install the rudder trim cover and knob.
- b. The primary control cable (13 or 17) in either wing may be installed by the following procedure:
 1. Draw the control cable into the wing.
 2. Connect the cable to the forward end of the aileron bellcrank (6) using a bolt, washer, nut and cotter pin. Allow the cable end to rotate freely on the bellcrank.
 3. If the primary control cable in the fuselage is installed, connect the ends at the turnbuckle (12 or 16) located under the rear seat aft of the main spar. Apply partial tension to cable to keep it from slipping off of pulleys (28 and 29).
 4. Install cable guard (31) on pulley (28).
 5. Check rigging and adjustment per Paragraph 5-12.
 6. Install the access plate on the underside of the wing.
- c. Either balance cable (18 or 19) may be installed by the following procedure:
 1. Draw the cable into the wing.
 2. Connect the cable to the aft end of the aileron bellcrank (6) using a bolt, washer, nut and cotter pin. Allow the cable end to rotate freely on the bellcrank.
 3. Connect the balance cable ends at the turnbuckle (24) that is located under the rear seat aft of the main spar. Apply partial tension to cable to keep it positioned on pulley (11).
 4. If the left cable was removed, install the cotter pin cable guard (32) at the pulley (11) located within the fuselage, aft of the main spar.
 5. Check rigging and adjustment per Paragraph 5-12.
 6. Install the access plate on the underside of the wing.
- d. Replace the rear seat floor panel and seats.

5-10. REMOVE OF AILERON BELLCRANK ASSEMBLY. (Refer to Figure 5-2.)

- a. Remove the rear seats and rear seats floor panel.
- b. Remove the access plate to the aileron bellcrank (6) located on the underside of the wing, forward of the inboard end of the aileron.
- c. Relieve tension from the aileron control cables by loosening the balance cable turnbuckle (24) located in the opening aft of the main spar.
- d. Disconnect the primary (13 or 17) and balance (18 or 19) control cables from the bellcrank assembly by removing cotter pins, nuts, washers and bolts.
- e. Disconnect the aileron control rod (7) at the aft of forward end, as desired, by removing the nut, washer and bolt.

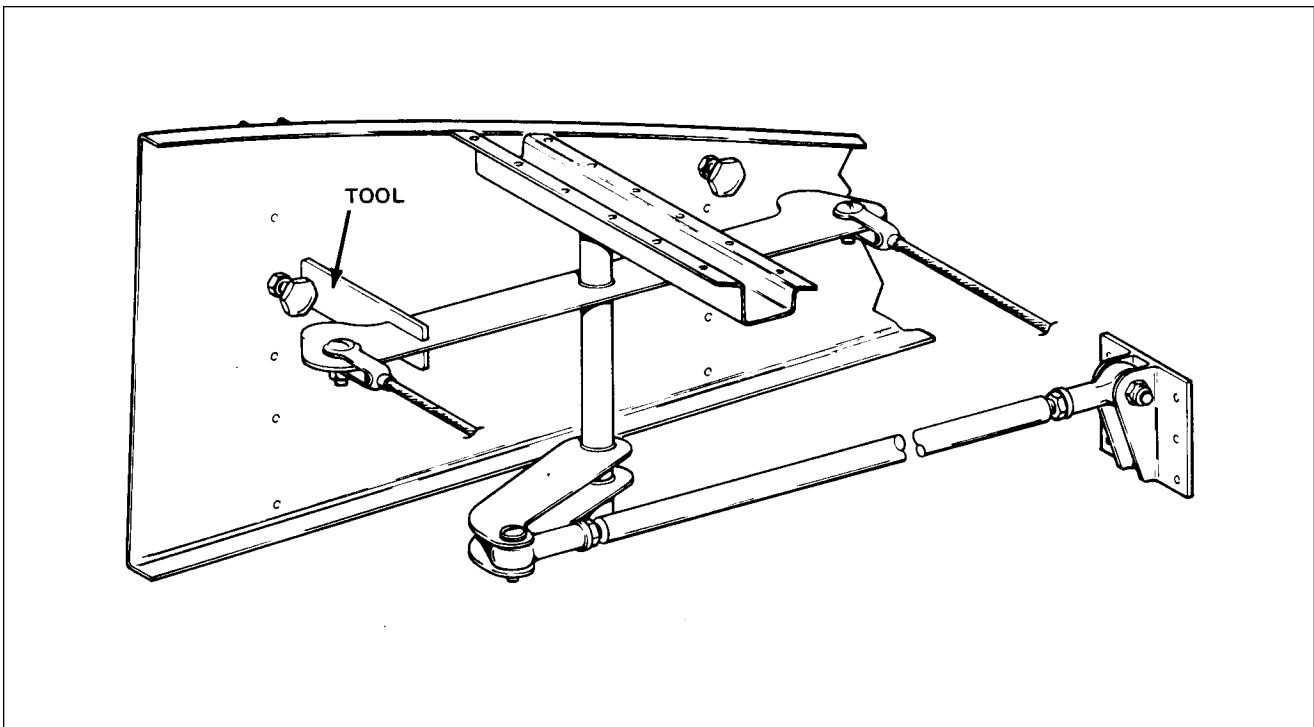

Figure 5-3. Bellcrank Rigging Tool

- f. Remove the nut, pivot bolt (25) and washers that secure the bellcrank. The nut is visible from the underside of the wing.
- g. Remove the bellcrank from within the wing.

5-11. INSTALLATION OF AILERON BELLCRANK ASSEMBLY. (Refer to Figure 5-2.)

- a. Ascertain that the bellcrank pivot bushing (26) and teflon tube (27) are installed in the torque tube portion of the bellcrank (6).
- b. Place the bellcrank in position in the wing with a washer located between each end of the torque tube and the mounting location.
- c. Install the bellcrank pivot bolt (25) with the head up. Install a washer and nut on the bolt, and torque nut within 20 to 25 inch-pounds. Check that the bellcrank rotates freely with little up-down play.
- d. Install and adjust control rod (7) and check aileron travel per Paragraph 5-12.
- e. Connect the ends of the primary (13 or 17) and balance (18 or 19) control cables to the bellcrank using bolts, washers, nuts and cotter pins. Allow the cable ends to rotate freely on the bellcrank.
- f. Tighten the control cables at the balance cable turnbuckle (24) in the floor opening aft of the main spar. Check cable tension per Paragraph 5-12.
- g. Install the access plate on the underside of the wing and replace the floor panel.

5-12. RIGGING AND ADJUSTMENT OF AILERON CONTROLS. (Refer to Figures 5-3 thru 5-4.)

NOTE

Flap adjustment must be complete before starting aileron adjustment.

- a. To check and adjust the rigging of the aileron controls, first set the right and left aileron bellcranks at neutral position. (Ascertain that the control chains have been rigged per Paragraph 5-6.) This may be accomplished by the following procedure:
 1. Place tee bar in full forward position, and maintain it in this position by use of a suitable tool or by placing weights on the aft side of the stabilator if the stabilator cables have been previously tensioned.
 2. Remove the access plate to each aileron bellcrank located on the underside of the wing, forward of the inboard end of the aileron by removing the plate attaching screws.
 3. Affix a bellcrank rigging tool, as shown in Figure 5-3, between the forward arm of each bellcrank and the adjacent outboard rib. (This tool may be fabricated from dimensions given in Figure 5-18.) The slotted end of the tool fits on the arm forward of and adjacent to the primary control cable end. The other end of the tool is positioned so that the side of the tool contacts the aft side of the bellcrank stop. The bellcrank must be moved to allow a snug fit of the tool between the bellcrank arm and rib. To do so, it may be necessary to loosen a primary control cable or the balance cable. Neutral position of the bellcranks may also be found by locating the position at which the forward and aft cable connection holes are an equal distance from the adjacent outboard wing rib.
- b. With each bellcrank set at neutral, the ailerons may be checked and adjusted for neutral as follows:
 1. Ascertain that the bellcrank rigging tool fits snug between the bellcrank and the rib.
 2. Place an aileron rigging tool as shown in Figure 5-4 against the underside of the wing and aileron as close as possible to the inboard end of the aileron without contacting any rivets. The tool must be positioned parallel with the wing ribs, with the aft end of the tool even with the trailing edge of the aileron. (This tool may be fabricated from dimensions given in Figure 5-19.)
 3. With the aileron control rod connected between the bellcrank and aileron, check that the surface of the wing contacts the tool at its forward surface and at the spacer, and the trailing edge of the flap contacts the aft end of the tool. The aileron is neutral at this position.
 4. Should the three points not contact; loosen the jam nut at the aft end of the control rod and rotate the rod until the three points contact. Apply a slight up pressure against the trailing edge of the aileron while making this adjustment. The aileron may be allowed to "droop" by approximately 1/8" of an inch at the inboard trailing edge. After adjustment, retighten the jam nut.
- c. Adjust primary and balance cable tension as given in Table V-1 by the following procedure:
 1. Remove the two front seats, if desired, and the rear seat floor panel to facilitate in the necessary operation.
 2. Loosen the connecting bolts of the idler cross-over sprockets at the control tee bar to allow the chain to fit snug around the control wheel sprockets and over the idler sprockets.
 3. Ascertain that both bellcranks are at neutral position.
 4. Adjust the turnbuckles, located in the access opening just aft of the main spar, of the primary and balance cables to their proper cable tension and maintain neutral-center position of the control wheels. Primary cable tension will be slightly less than balance cable tension, but still should be within the tension specified. Adjust the cables so that the inboard end of the ailerons visually lines up with the outboard end of the flap when a slight up pressure is applied to the middle of the aileron to take the slack out of the hinge and linkage. To obtain neutral position of both control wheels, it may also be necessary to adjust the roller chain turnbuckle located between the control wheel sprockets. During adjustment, obtain a little more tension on the primary control cables to hold the bellcranks in neutral against the rigging tools, finishing with even tension on all cables.

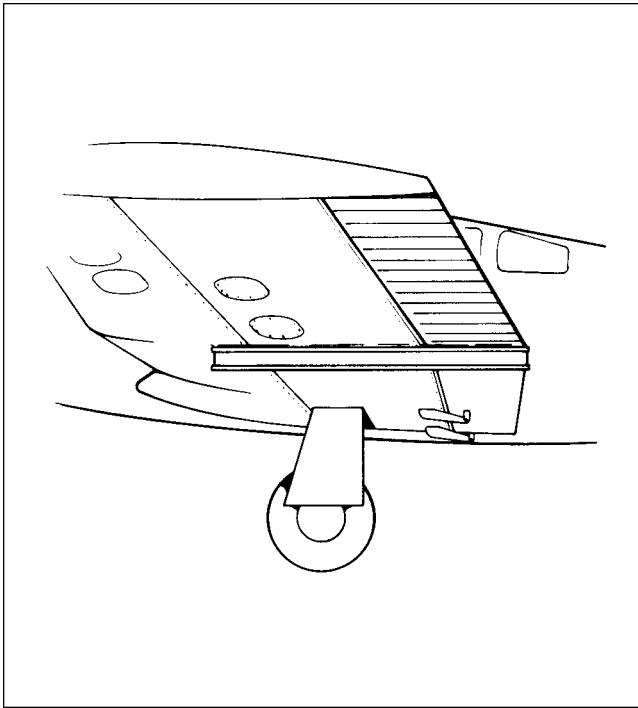

Figure 5-4. Aileron Rigging Tool



Figure 5-5. Stabilator Rigging Tool

5. Tighten the bolts to secure the idler cross-over sprockets.
 6. Remove any rigging locks or tools previously installed.
- d. Check the ailerons for correct travel from neutral per dimensions given in Table V-1, by the following procedure:
1. Center the bubble of a protractor over the surface of an aileron at neutral position and note the reading.
 2. Move the aileron full up and down, and check the degree of travel for each direction. When measuring the full down position of the aileron, maintain a light up pressure at the center of the trailing edge of the aileron. When measuring the full up position of the aileron, maintain a light down pressure at the center of the trailing edge of the aileron. This pressure should be just sufficient to remove the slack between the bellcrank and aileron. The degree of travel on the protractor is determined by taking the difference between the protractor reading at neutral and up, and neutral and down. The bubble must be centered at each reading.
 3. Should the travel not be correct, the travel may be set by rotating the bellcrank stops in or out. Stops are located in the wing attached to the rib that is adjacent to the aileron bellcrank.
 4. Repeat this procedure for the other aileron.
- e. Check to insure that the left aileron up and right aileron down stops are contacted simultaneously and vice versa. Adjust stops as required.
- f. Check the bellcrank stops to assure that the bellcrank contact is made simultaneously, but still have cushion before contacting the control wheel stops. Maintain .030 to .040 clearance between sprocket pin and adjustable stop bolts on the tee bar.

NOTE

When an out of trim condition persists despite all the rigging corrections that can be made, there is a possibility that the trailing edge of the aileron has been used to move the aircraft forward. This can result in a slight bulging of the aileron contour at the trailing edge which will cause an out of rig condition that is very difficult to correct.

- g. Check complete system for safety of turnbuckle, bolts, and smooth operation without binding or chafing.
- h. Install access plates and panels.

5-13. STABILATOR CONTROLS.

5-14. REMOVAL OF STABILATOR CONTROL CABLES. (Refer to Figure 5-6.)

- a. To remove either the forward or aft stabilator cables, first remove the access panel to the aft section of the fuselage located in the baggage compartment, the two front seats, and the rear seats floor panel.
- b. Disconnect the desired control cable at the turnbuckle in the aft section of the fuselage.
- c. Either forward stabilator cable (2 or 3) may be removed by the following procedure:
 - 1. Remove the tunnel carpet and cover plate by removing the rudder trim control knob and trim cover attaching screws. Roll back the carpet from the tunnel and remove the tunnel plate that is located just aft of the tee bar assembly by removing the plate attaching screws.
 - 2. Remove stabilator control cables by first removing the cotter pin guards at the pulleys (14) located in the forward area of the tunnel.
 - 3. Disconnect the cables from the arm assembly (21) by removing the cotter pin, nut, washer and bolt (22).
 - 4. Within the access opening aft of the main spar, remove the cable rub blocks that are attached to the spar housing by removing the block attaching screws.
 - 5. Remove the cotter pin cable guard at the pulley cluster located in the aft area the access opening aft of the main spar.

NOTE

To facilitate in the installation of control cables, a line may be attached to the cable end prior to removal.

- 6. Draw the cables aft through the floor tunnel.
- d. Either aft stabilator control cable (4 or 5) may be removed by the following procedure:
 - 1. Disconnect the cable end at the balance arm (18) of the stabilator by removing the cotter pin, nut, washer and bolt (8).
 - 2. Remove the cotter pin cable guard at the pulley (7) located either above or below the balance arm.
 - 3. Remove the cable from the airplane.

NOTE

Examine cables for broken strands by wiping the cable along its length. Visually check for damage. Replace all damaged cables.

5-15. INSTALLATION OF STABILATOR CONTROL CABLES. (Refer to Figure 5-6.)

- a. The forward stabilator cables (2 and 3) may be installed by the following procedure:
 - 1. Draw the control cable through the floor tunnel. Ascertain that the right (upper) cable (2) is routed around the pulleys (14) in the forward area of the floor tunnel.
 - 2. Position the stabilator cables (2 and 3) into the arm assembly (21) along with the link assembly (20). (Refer to Figure 5-6 View A for correct positioning of components.) Secure the complete installation with bolt, washers, nut and cotter pin (22). Ascertain that no binding or excessive end play is evident in the hookup.
 - 3. If the aft control cable (4 or 5) is not installed, install per Step b.
 - 4. Connect the control cable to the aft cable at the turnbuckle (16) in the aft section of the fuselage. Apply partial tension to cable to keep it positioned on pulleys.
 - 5. For the right control cable (2), install the cotter pin cable guards at the pulley(s) (14) in the forward area of the tunnel.
 - 6. Within the access opening aft of the main spar, install the cable run blocks (10) to the spar housing and secure with screws.
 - 7. In the access opening, install the cotter pin cable guard at the pulley cluster (6).
 - 8. Set the tension and check rigging and adjustment per Paragraph 5-16.

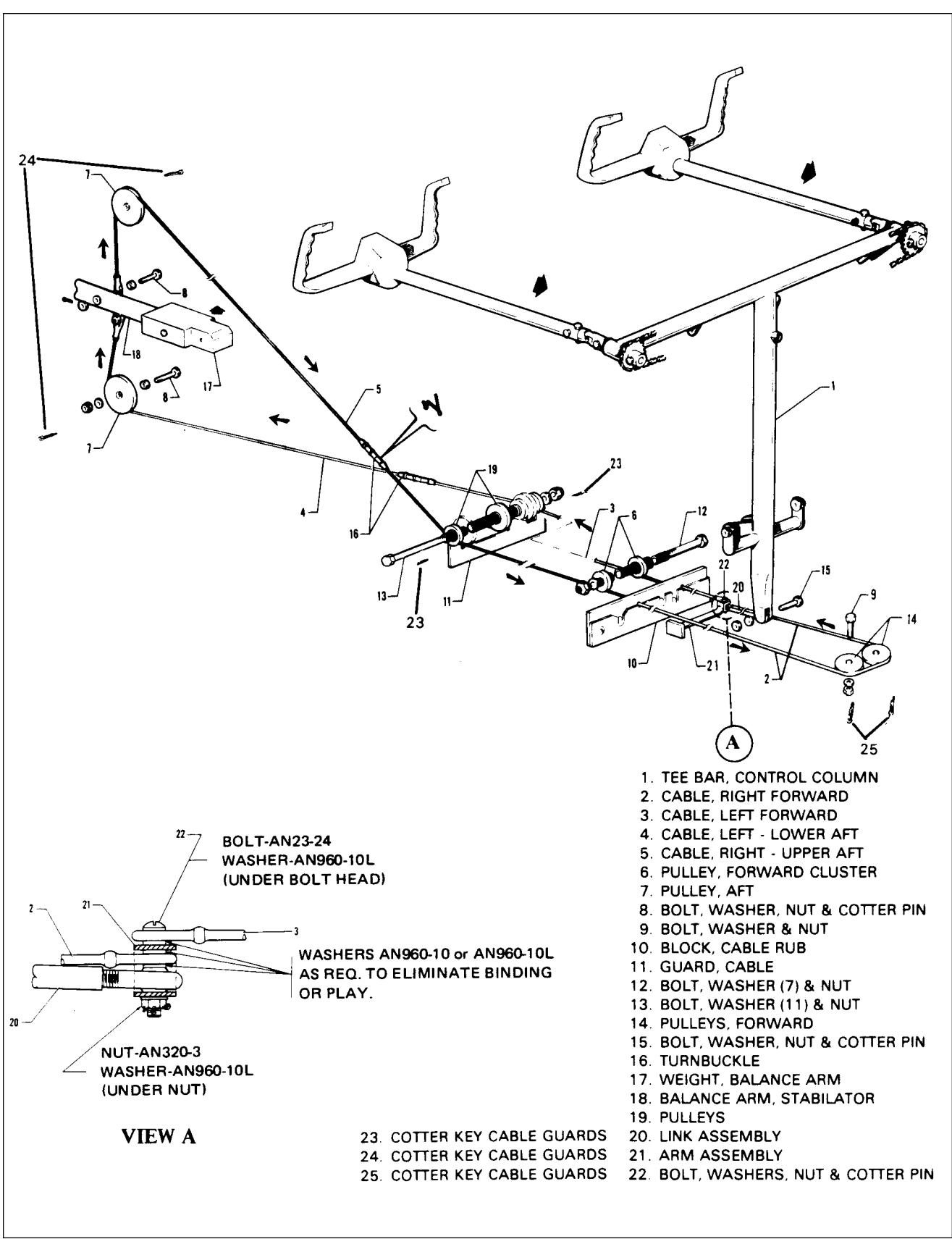

- 1. TEE BAR, CONTROL COLUMN
- 2. CABLE, RIGHT FORWARD
- 3. CABLE, LEFT FORWARD
- 4. CABLE, LEFT - LOWER AFT
- 5. CABLE, RIGHT - UPPER AFT
- 6. PULLEY, FORWARD CLUSTER
- 7. PULLEY, AFT
- 8. BOLT, WASHER, NUT & COTTER PIN
- 9. BOLT, WASHER & NUT
- 10. BLOCK, CABLE RUB
- 11. GUARD, CABLE
- 12. BOLT, WASHER (7) & NUT
- 13. BOLT, WASHER (11) & NUT
- 14. PULLEYS, FORWARD
- 15. BOLT, WASHER, NUT & COTTER PIN
- 16. TURNBUCKLE
- 17. WEIGHT, BALANCE ARM
- 18. BALANCE ARM, STABILATOR
- 19. PULLEYS
- 20. LINK ASSEMBLY
- 21. ARM ASSEMBLY
- 22. BOLT, WASHERS, NUT & COTTER PIN
- 23. COTTER KEY CABLE GUARDS
- 24. COTTER KEY CABLE GUARDS
- 25. COTTER KEY CABLE GUARDS

22 BOLT-AN23-24
 WASHER-AN960-10L
 (UNDER BOLT HEAD)

21 WASHERS AN960-10 or AN960-10L
 AS REQ. TO ELIMINATE BINDING
 OR PLAY.

20 NUT-AN320-3
 WASHER-AN960-10L
 (UNDER NUT)

VIEW A

Figure 5-6. Stabilator Controls

9. Install the floor tunnel plate and trim covers by placing the tunnel plate into position for installation and secure with the attaching screws. Roll the carpet into place and install the rudder trim cover and knob.
10. Install the front seats and rear seat floor panel.
- b. Either aft stabilator control cable (4 or 5) may be installed by the following procedure:
 1. Route the cable (4 or 5) around its pulley (7) located either over or under the balance arm (18) of the stabilator.
 2. Connect the cable to the stabilator balance arm and secure with bolt, washer, nut and cotter pin (8). (Insure bushing is installed with bolt.)
 3. Connect the cable to the forward cable at the turnbuckle (16) in the aft section of the fuselage. The upper aft cable (5) connect to the right forward cable (2) and the lower cable (4) to the left cable (3).
 4. Install the cotter pin cable guard at the pulley (7), where required.
 5. Set cable tension and check rigging and adjustment per Paragraph 5-17.
 6. Install the seats and access panels.

5-16. RIGGING AND ADJUSTMENT OF STABILATOR CONTROLS.

- a. Level the airplane. (Refer to Leveling, Section II.)
- b. To check and set the correct degree of stabilator travel, the following procedure may be used:
 1. Check the stabilator travel by placing a rigging tool on the upper surface of the stabilator as shown in Figure 5-5 (This tool may be fabricated from dimensions given in Figure 5-20.)
 2. Set on a bubble protractor the number of degree up travel as given in Table V-I and place it on the rigging tool. Raise the trailing edge of the stabilator and determine that when the stabilator contacts its stops, the bubble of the protractor is centered.

NOTE

The stabilator should contact both of its stops before the control wheel contacts its stops.

3. Set on the protractor the number of degrees down travel as given in-Table V-I and again place it on the rigging tool. Lower the trailing edge of the stabilator and determine that when it contacts its stops, the bubble of the protractor is centered.
4. Should the stabilator travel be incorrect in either the up or down position, remove the tail cone fairing by removing the attaching screws and with the use of the rigging tool and bubble protractor turn the stops located at each stabilator hinge in or out (Refer to Figure 5-13.) to obtain the correct degree of travel.
5. Ascertain that the lock nuts of the stop screws are secure and reinstall the tail cone fairing.
- c. To check and set stabilator control cable tension, the following procedure may be used:
 1. Ascertain that the stabilator travel is correct.
 2. Remove the access panel to the aft section of the fuselage.
 3. Secure the control column in the near forward position. Allow $1/4 + 1/32$ inch between the column aft the stop bumper.
 4. Check each control cable for the correct tension as given in Table V-I.
 5. Should tension be incorrect, loosen the turnbuckle of the lower cable in the aft section of the fuselage and adjust the turnbuckle of the upper cable to obtain correct tension. Cable tension should be obtained with the control wheel at the $1/4 + 1/32$ inch dimension from the stop and the stabilator contacting its stop.
 6. Check safety of all turnbuckles and bolts.

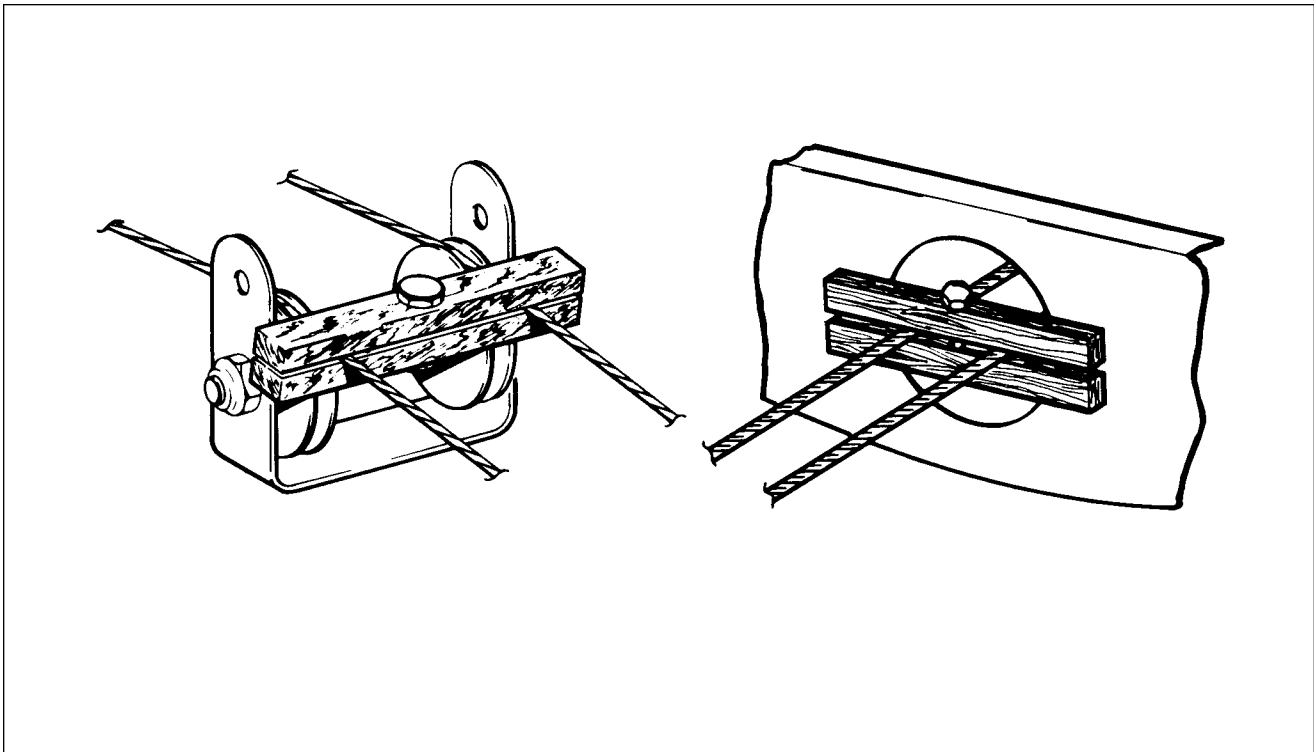

Figure 5-7. Methods of Securing Trim Cables

7. With the tension of the upper cable correct and the control wheel still forward, adjust the turnbuckle of the lower cable to obtain correct tension.
 8. Check the full travel of the control wheel with relation to the full travel of the stabilator to determine that the stabilator contacts its stops before the control wheel contacts its stops. With the control wheel in the fore and aft positions, the travel distance from the point where the stabilator contacts its stops and the control wheel contacts its stops should be approximately equal. Readjust turnbuckles if incorrect.
 9. Reinstall access panels.
- d. Remove the airplane from jacks.

5-17. STABILATOR TRIM CONTROLS.

5-18. REMOVAL OF STABILATOR TRIM ASSEMBLY. (FORWARD.) (Refer to Figure 5-8.)

- a. To remove the trim control wheel assembly and/or the trim control cables, first remove the panel to the aft section of the airplane.
- b. If the aft trim cable (12) is not to be removed, block the cables at the pulleys (13) in the upper aft section of the fuselage to prevent them from unwrapping from the trim drum. (Refer to Figure 5-7.)
- c. Loosen the cables if the trim control wheel (1) is to be removed or disconnect if the cables are also to be removed. Do this at the trim cable turnbuckles (10 and 11) in the aft section of the fuselage.
- d. The control wheel (1) with drum (3) may be removed by the following procedure:
 1. Remove the control wheel cover by removing the cover attaching screws.
 2. The wheel assembly may be removed from its mounting brackets by removing nut, washer and bolt (7) that secures the wheel between the brackets. Draw the wheel from the brackets. Use caution not to damage trim indicator wire(2).
 3. Unwrap the left cable (9) from the drum.

4. The wheel and drum are joined by a push fit, separate these two items with their center bushing and unwrap the right cable (8).
5. Tie the cables forward to prevent them from slipping back into the floor tunnel.
- e. The trim control cables (8 and 9) may be removed by the following procedure:
 1. Remove the rear seat and the front seats, if desired.
 2. Unfasten the carpet from the aft portion of the floor tunnel and lay it forward.
 3. Remove the tunnel cover located between the trim control wheel and the spar cover by removing attaching screws.
 4. Remove the cable pulleys (6) located in the tunnel by removing the cotter pin, washer and clevis pin (5).
 5. Remove the cable rub blocks (37) located on the aft side of the main spar by removing the block attaching screws.
 6. Remove the cable guard pin (36) at the pulley cluster (34) located just aft of the wing flap torque tube at station 127.25.
 7. If installed, remove the cable pulleys (33) within the aft section of the fuselage at station 156.5 by removing nut, washer, bushing and bolt.
 8. With the cables disconnected from the trim control wheel, draw the cable(s) through the floor tunnel.

NOTE

Examine cables for broken strands by wiping the cable along its length. Visually check for damage. Replace all damaged cables.

5-19. INSTALLATION OF STABILATOR TRIM ASSEMBLY. (FORWARD) (Refer to Figure 5-8.)

- a. The trim control wheel with drum may be installed by the following procedure:
 1. Wrap the right trim cable on the trim drum by inserting the swaged ball of the cable in the slot provided in the side (right side) of the drum that mates with the control wheel, and looking at this side, wrap the drum with three wraps of the cable in a clockwise direction.
 2. Attach the control wheel to the cable drum by aligning the long lug of the drum with the long slot of the wheel and pushing the two pieces together.
 3. Wrap the left trim cable on the drum by inserting the swaged ball of the cable in the slot provided in the flanged side (left side) of the drum and looking at this side, wrap the drum with three wraps of the cable in a clockwise direction.
 4. Lubricate and install the bushing in the control wheel and drum.
 5. Align the control cables and position the control wheel assembly between its mounting brackets. Ascertain that the end of the trim indicator wire is positioned in the spiraled slot of the drum with no bind on the end. Install the retainer bolt from the left side and install washer and nut.
 6. Install the cover over the control wheel and secure with screws, unless the control cables have yet to be installed.
- b. The trim control cables may be installed by the following procedure:
 1. Draw the cable(s) through the floor tunnel.
 2. Wrap the cable drum and install the trim control wheel as given in Step a.
 3. Position the cable pulleys on their mounting bracket within the floor tunnel and install the clevis pin, washer and cotter pin.
 4. Connect the cable to the aft cable at the turnbuckle in the aft section of the fuselage. Install aft cable if not installed.
 5. If previously installed, install the pulleys in the aft lower section of the fuselage at station 156.5 forward of the cable turnbuckles. Apply partial tension to cable to keep it positioned on pulleys.
 6. Install the cable guard at the underside of the pulleys located just aft of the flap torque tube at station 127.25 and secure.
 7. Install the cable rub blocks located on the aft side of the main spar housing and secure with screws.
 8. Remove the blocks that secure the aft trim cable and check that the cables are seated on their pulleys.

- c. Set cable tension and check rigging and adjustment per Paragraph 5-22. Check safety of all turnbuckles.
- d. Install the tunnel cover on the tunnel and secure with screws.
- e. Install the carpet over the floor tunnel.
- f. Install the cover over the trim control wheel and secure with screws and special washers.
- g. Install the floor panel and seat belt attachments aft of the main spar and secure panel with screws.
- h. Install the panel to the aft section of the airplane and the seats.

5-20 REMOVAL OF STABILATOR TRIM ASSEMBLY. (AFT) (Refer to Figure 5-8.)

- a. Remove the access panel to the aft section of the fuselage.
- b. Block the trim cables at the first set of pulleys (33) forward of the cable turnbuckles (10 and 11) in the aft section of the fuselage by a method shown in Figure 5-7.
- c. Disconnect the cable (12) at the turnbuckles (10 and 11) in the aft section of the fuselage.
- d. Remove the tail cone by removing its attaching screws.
- e. Disconnect the link (25) between the trim screw (23) and the trim control arm (28) by removing the nut, washer and bolt (24) that connects the link to the screw.
- f. Remove the cotter pin from the top of the screw (23), and turn the screw down and out of the barrel (20).
- g. Remove the snap ring (32), washer (31) and thrust washer (30) from the bottom of the barrel.
- h. Disconnect the diagonal rib (22) from the horizontal rib (16) that supports the trim assembly by removing the four attaching nuts, washers and bolts.
- i. Draw the trim cable (12) from the fuselage.

5-21. INSTALLATION OF STABILATOR TRIM ASSEMBLY. (AFT.) (Refer to Figure 5-8.)

- a. Wrap the trim barrel (20) by first laying the center (as measured equally from each end to the center of the cable) of the trim cable (12) in the slot of the barrel, Bring the upper cable through the diagonal slot in the flange at the upper end of the barrel and wrap down in a counterclockwise direction. Bring the lower cable through the diagonal slot in the lower end of the barrel and wrap up in a clockwise direction. Wrap the cable as evenly as possible to obtain 23 wraps on the barrel as viewed from the side opposite the slot and with the cables extending out from the slotted side.
- b. Block both cables by clamping them between two pieces of wood laid next to the wraps to prevent them from unwrapping.
- c. Ascertain that the barrel bushings (19 and 29) are installed in the rib plate (17) and clip (21).
- d. Lubricate the bushings and install the trim barrel (20) in the bushings between the two support ribs. Attach the bottom diagonal rib (22) to horizontal rib (16) and secure with bolt, washers and nuts.
- e. Install the thrust washer (30), washer (31) and snap ring (32) on the lower end of the barrel.
- f. Install the trim screw (23) in the barrel (20) and secure each end with a cotter pin through the screw.
- g. Route the cables into the fuselage and attach the ends to the forward trim cables (8 and 9).
- h. Remove the blocks that are holding the forward cables tight and aft cables at the barrel.
- i. Set cable tension and check rigging and adjustment per Paragraph 5-22. Check safety of all turnbuckles.
- j. Install the tail cone and secure with screws.
- k. Install the access panel to the aft section of the fuselage.

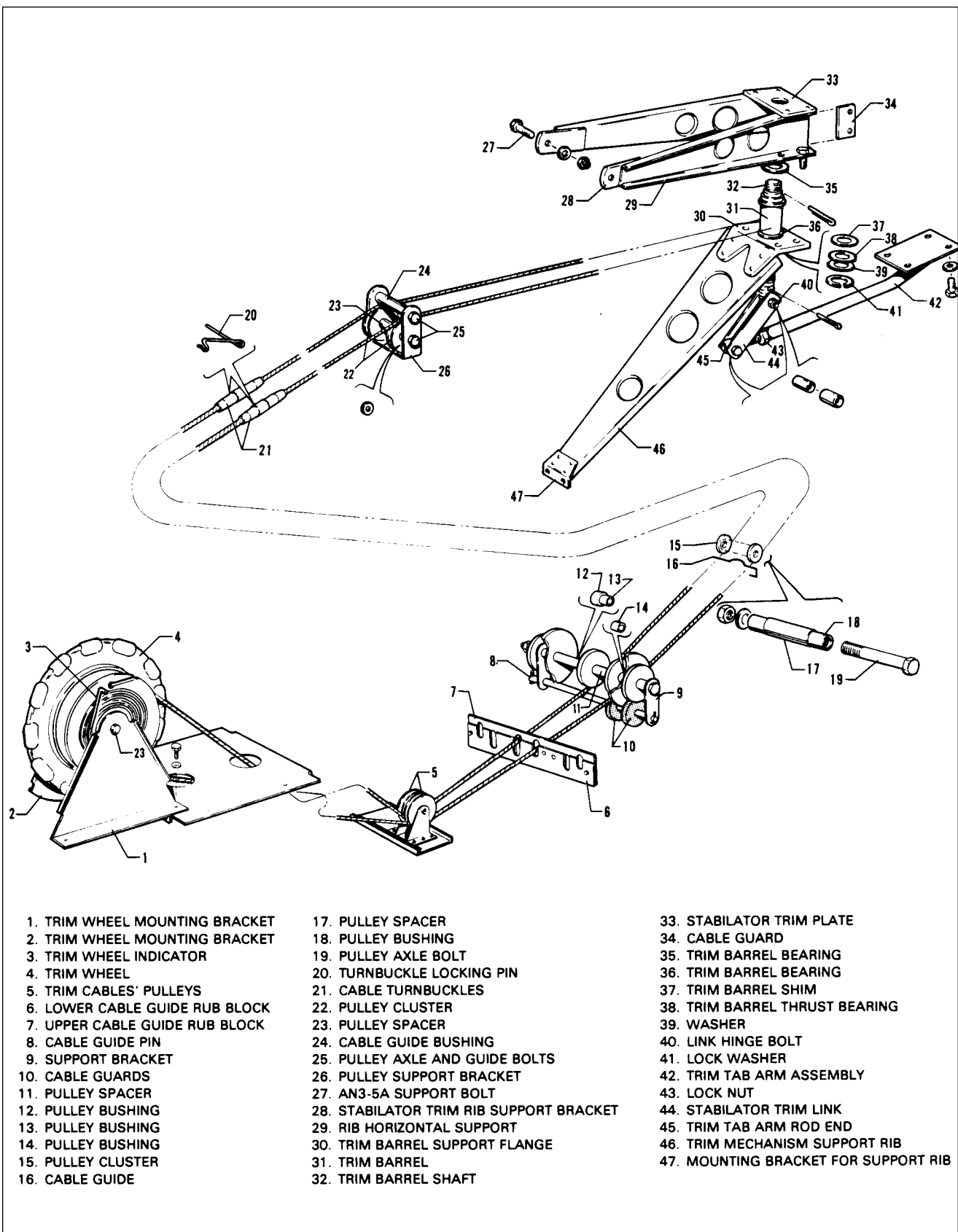

Figure 5-8. Stabilator Trim Control

5-22. RIGGING AND ADJUSTMENT OF STABILATOR TRIM. (Refer to Figure 5-8.)

- a. Level the airplane. (Refer to Leveling, Section II.)
- b. Check for proper stabilator trim cable tension as given to Table V-I. If cables were disconnected, rotate control wheel several times to allow the cables to seat and recheck tension.
- c. Secure the stabilator in neutral position. To find neutral, place a rigging tool on the upper surface of the stabilator as shown in Figure 5-5. Zero a bubble protractor, set it on the rigging tool and tilt the stabilator until the bubble is centered.
- d. With the stabilator centered, turn the trim wheel (1) until the aft end of the turnbuckle (10) of the right trim cable (8) is approximately two inches forward of the double pulleys (13) at the top of the rear bulkhead at station 228.3.
- e. Check that the trim screw (23) is turned down until the cotter pin stop in the top of the screw is contacting the plate (17) on the horizontal support rib (16) of the trim assembly. If the stop is not contacting the plate, the links (25) between the screw (23) and the trim control arm (28) are not disconnected, disconnect the two by removing the connecting nut, washers and bolt (24). With the turnbuckle still at the two inch dimension from the pulley, turn the screw down until the pin contacts the plate.
- f. Check the rod end (26) on the tab actuating arm (28) for approximately six threads forward of the jam nut (27).
- g. Connect the links to the trim screw and secure with bolt, washers and nut.
- h. Turn the trim control wheel until the trim tab streamlines with the neutral stabilator.
- i. Check the bubble of the protractor over the neutral tab and then check tab travels as given in Table V-I. The degree of travel on the protractor is determined by taking the difference between the protractor reading at neutral and up, and neutral and down. The bubble must be centered at each reading with the airplane level.
- j. To obtain correct travels, if incorrect, adjust by disconnecting the links (25) at the actuating arm rod end (26) and turning the end in or out as required. Reconnect links to rod end.
- k. Secure the jam nut (27) on the actuating arm rod end.
- l. Turn the trim wheel to full travel and check for pulley and turnbuckle clearance and location of tab indicator.
- m. Check total free play of trim tab, it should not exceed 0.06 inch.

5-23. RUDDER AND STEERING PEDAL ASSEMBLY.

5-24. REMOVAL OF RUDDER AND STEERING PEDAL ASSEMBLY. (Refer to Figure 5-9.)

- a. Remove the access panel to the aft section of the fuselage.
- b. Relieve rudder and stabilator cable tension by loosening one of the rudder and stabilator cable turnbuckles in the aft section of the fuselage.
- c. Remove the tunnel plate located just aft of the tee bar assembly by removing the rudder trim control knob, trim cover attaching screws and trim cover. Roll back the carpet from the tunnel and remove the tunnel plate that is located just aft of the tee bar assembly by removing the plate attaching screws.
- d. Disconnect the stabilator control cable from the lower end of the tee bar assembly.
- e. Remove the tee bar attaching bolts with their washers and nuts which are through each side of the floor tunnel. Pull the lower end of the tee bar aft.
- f. Disconnect the control cable (19) ends from the arms on the torque tube (3) by removing the cotter pins, washers, nuts and bolts (20).
- g. Disconnect the rudder trim from the torque tube assembly by removing the cotter pin, washers and bolt that connects the arm to the trim. Remove the cotter pin and clevis pin from the rudder trim mechanism and remove the mechanism from the mounting channel. Remove the screw from the engine control bracket assembly and swing it out of the way. Disconnect the alternate air cable and move aside.
- h. Disconnect the steering rods (21) at the rudder (32 and 33) by removing nuts and bolts (24).
- i. Disconnect the brake cylinders (12) at the lower end of each cylinder rod (11) by removing the cotter pins, washers, nut and bolts (20).

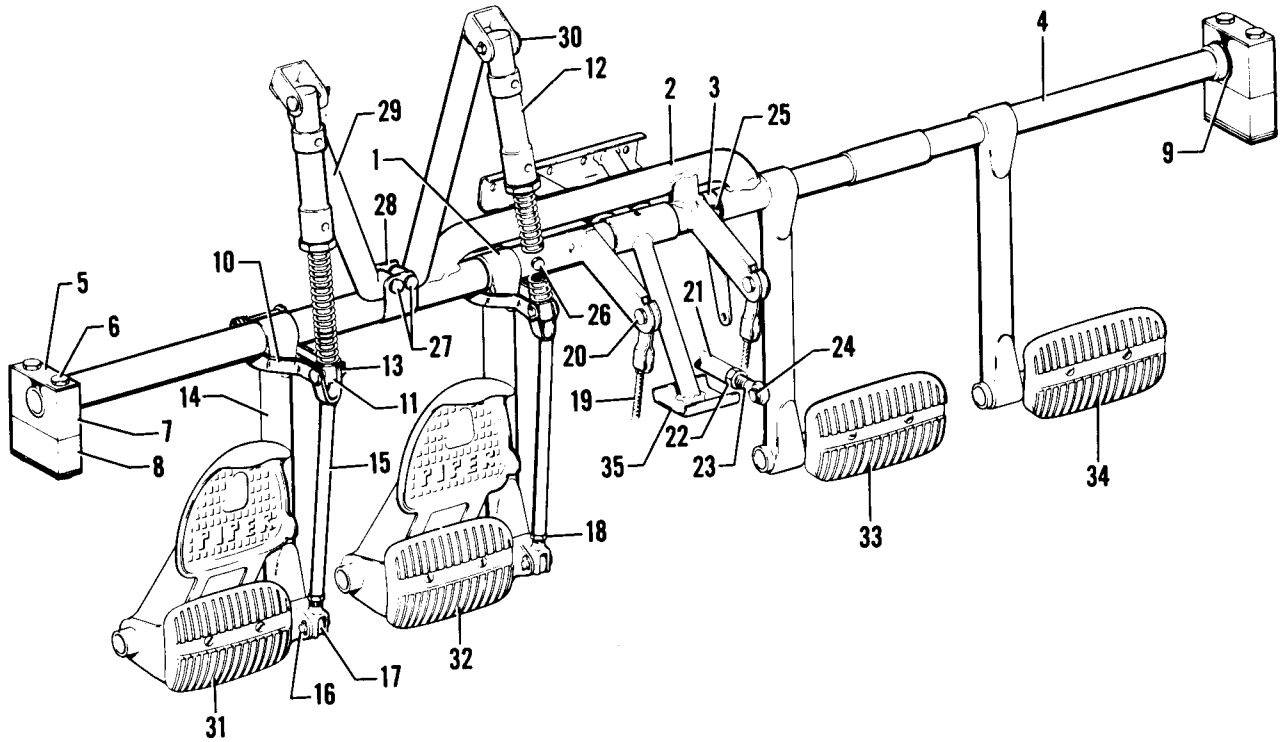

- | | | |
|-------------------------|------------------------------------|-----------------------------|
| 1. TUBE, L. OUTER | 12. BRAKE CYLINDER | 24. BOLT & NUT |
| 2. TUBE, L. CENTER | 13. CLEVIS PIN & COTTER PIN | 25. BOLT, WASHER & NUT |
| 3. TUBE, R. CENTER | 14. TUBE, RUDDER CONTROL | 26. BOLT, WASHER & NUT |
| 4. TUBE, R. OUTER | 15. CLEVIS ROD | 27. BOLT, WASHER & NUT |
| 5. PLATE | 16. CLEVIS PIN & COTTER PIN | 28. BRACKET |
| 6. BOLT & NUT | 17. ROD END | 29. VEE BRACE |
| 7. SUPPORT BLOCK, UPPER | 18. JAM NUT | 30. CLEVIS PIN & COTTER PIN |
| 8. SUPPORT BLOCK, LOWER | 19. CONTROL CABLE, RUDDER | 31. RUDDER PEDAL, L. OUTER |
| 9. WASHER, SPACER | 20. BOLT, WASHER, NUT & COTTER PIN | 32. RUDDER PEDAL, L. INNER |
| 10. ARM, IDLER | 21. ROD, NOSE WHEEL STEERING | 33. RUDDER PEDAL, R. INNER |
| 11. ROD, BRAKE CYLINDER | 22. JAM NUT | 34. RUDDER PEDAL, R. OUTER |
| | 23. ROD END, STEERING | 35. BRACKET, TUBE SUPPORT |

Figure 5-9. Rudder and Steering Pedal Assembly

- j. Disconnect the vee brace(s) (29) (two braces are used with right hand brakes) from the torque tube by removing nuts, washers and bolts (27) that secure the strap bracket (28) to the vee brace.
- k. Disconnect the torque tube support bracket (35) where it attaches by removing the two bolts attached to the box located beneath, and the four bolts attached to the forward bulkhead.
- l. Remove the two bolts (25 and 26) that extend through the torque tube and are located at the center of the tube assembly over the floor tunnel. Compress the tubes. Remove the left and right toe brake pedal assembly.
- m. Disconnect the torque tube support blocks (7 and 8) from their support brackets on each side of the fuselage by removing the attaching nuts, washers and bolts (6).
- n. Remove the trim side panels, if desired.
- o. Rotate the rudder pedal bar assembly toward the cabin door far enough to pull the right pedal bar out. Rotate the remaining assembly to the left and remove the assembly from the aircraft. Note the spacers and washers (9) on each end and between the support blocks.

5-25. INSTALLATION OF RUDDER AND STEERING PEDAL ASSEMBLY. (Refer to Figure 5-9.)

- a. Assemble the torque tube assembly (1, 2, 3 and 4) as shown in Figure 5-9. Do not at this time install the two bolts (25 and 26) through the center of the tube assembly.
- b. Place the upper support blocks (7) on the ends of the torque tube assembly. Note that a washer (9) is required on each end of the tube.
- c. Position the support blocks (7 and 8) on their mounting brackets at each side of the fuselage and secure with bolts, washers and nuts. Note that a bushing is required in the bolt holes of the upper support block, a plate on top of the upper block, between the upper and lower blocks and under the block mounting bracket.
- d. Align the bolt holes in the center area of the torque tube assembly, install bolts, washers and nuts (25 and 26) and tighten.
- e. Position the torque tube support bracket (35) on the floor tunnel and secure with bolts.
- f. Position the vee brace(s) (29) on the torque tube, install the strap bracket (28) around the torque tube and brace and secure with bolts, washers and nuts (27).
- g. Check that the rod end (17) on the clevis rod (15) is adjusted to give a dimension of 7.94 inches between hole centers.
- h. Connect the ends of the brake cylinder rods (11) and clevis rods (15) to the idler arms (10) and secure with clevis and cotter pins (13).
- i. Connect the steering rods (21) to the rudder pedals (32 and 33) and secure with bolts and nuts (24). Check steering rod adjustment per Alignment of Nose Gear, Section VII.
- j. Connect the rudder trim to the arm of the torque tube and secure with bolt, washer, nut and cotter pin. A thin washer is installed under the nut which is tightened only finger tight.
- k. Connect the ends of the rudder control cables (19) to the arms provided on the torque tube and secure with bolts, washers, nuts and cotter pins (20). Allow the ends free to rotate.
- l. Swing the tee bar into place and secure with attachment bolts, washers and nuts (15). Insert bolts through each side of the floor tunnel. (See Figure 5-1).
- m. Connect the stabilator control cables (11) to the lower end of the tee bar with bolt, washer and nut (16), and secure with cotter pin. (See Figure 5-1). Allow the cable ends to rotate freely.
- n. Set rudder cable tension and check rigging and adjustment per Paragraph 5-33.
- o. Set stabilator cable tension and check rigging and adjustment per Paragraph 5-16.
- p. Check aileron cable tension.
- q. Check safety of bolt and turnbuckles.
- r. Install the floor tunnel plate and secure with screws. Fasten the tunnel carpet in place.
- s. Install the rudder trim cover and control knob.
- t. Install the access to the aft section of the fuselage.

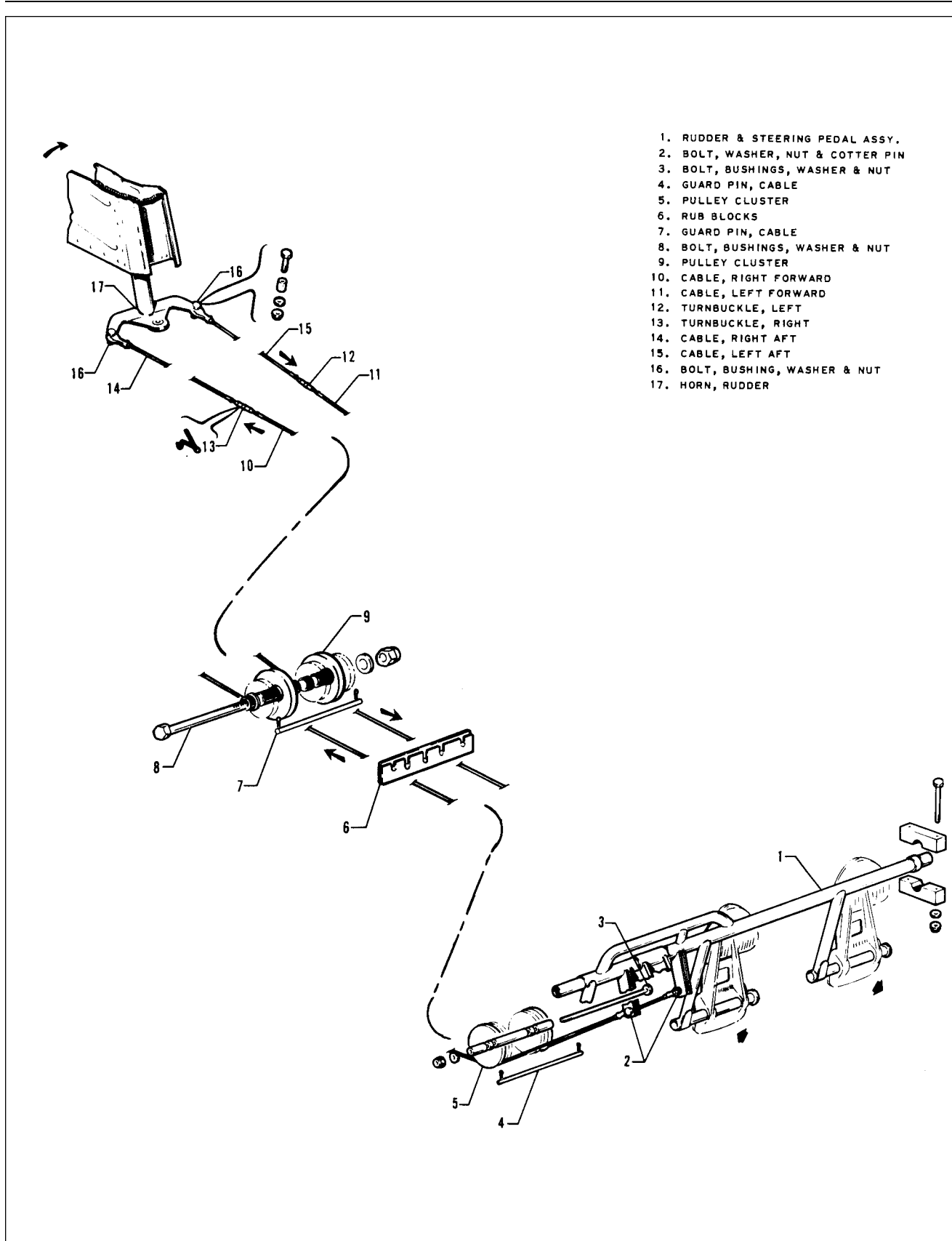

Figure 5-10. Rudder Controls

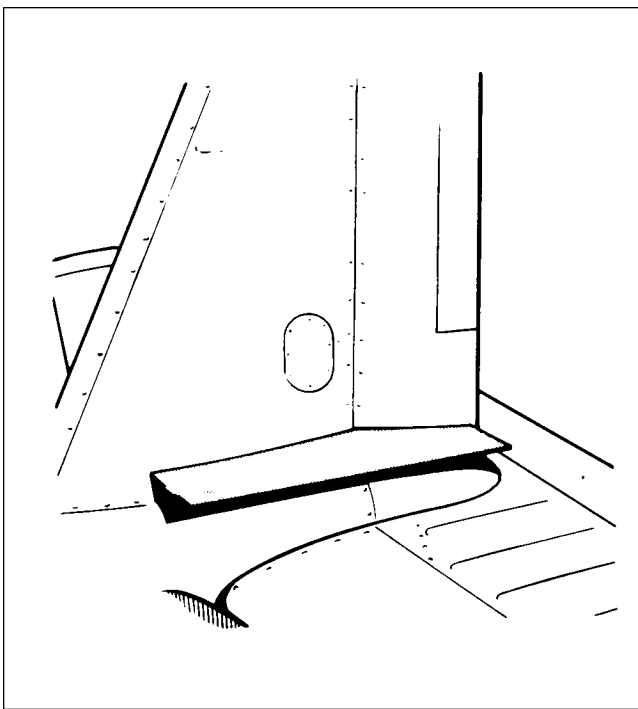

Figure 5-11. Rudder Rigging Tool

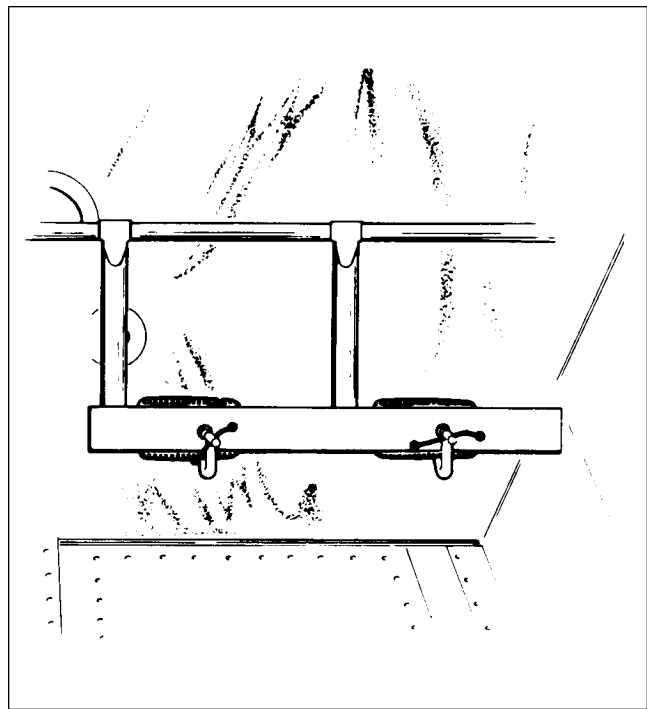

Figure 5-12. Clamping Rudder Pedals

5-26. RUDDER CONTROLS.

5-27. REMOVAL OF RUDDER CONTROL CABLES. (Refer to Figure 5-10.)

- a. To remove either the forward (10 or 11) or aft (14 or 15) rudder cables, first remove the access panel to the aft section of the fuselage.
- b. Disconnect the desired cable at the turnbuckle (12 or 13) in the aft section of the fuselage.
- c. Either forward rudder cable may be removed by the following procedure:
 1. Remove the rear seat floor panel and the front seats.
 2. Remove the cable guard pin (7) from the underside of the pulley cluster (9) that is located in the aft area of the flap torque tube.
 3. From within the area aft of the main spar, remove the cable rub blocks (6) that are attached to the spar housing by removing the block attaching screws.
 4. Remove the rudder trim knob and the cover attaching screws.
 5. Remove the tunnel plate just aft of the tee bar by removing enough carpet from the tunnel to allow the plate attaching screws and the plate to be removed.
 6. Move the cable guard pin (4) located under the pulley cluster (5) just aft of the tee bar by removing the cotter pin from the exposed end and sliding it to the left or right, as required.
 7. Disconnect the end of the cable from the arm on the rudder pedal torque tube by removing the cotter pin, nut, washer and bolt (2).
 8. Draw the cable from the floor tunnel.
- d. The aft rudder control cables may be removed by the following procedure:
 1. Remove the tail cone fairing by removing its attaching screws.
 2. Disconnect the cable (14 or 15) from the rudder horn (17) by removing cotter pin, nut, washer and bolt (16).
 3. Draw the cable through the fuselage.

NOTE

Examine cables for broken strands by wiping the cable along its length. Visually check for damage. Replace all damaged cables.

5-28. INSTALLATION OF RUDDER CONTROL CABLES. (Refer to Figure 5-10.)

- a. The forward rudder control cables may be installed by the following procedure:
 1. Draw the control cable through the floor tunnel.
 2. Connect the end of the cable to the arm on the rudder pedal torque tube by installing bolt, washer, nut and cotter pin (2). Allow the cable end free to rotate on the arm.
 3. Connect the cable to the aft control cable at the turnbuckle (12 or 13) in the aft section of the fuselage. If the aft control cables are not installed, install at this time per Step b. Apply partial tension to cable to keep it positioned on the pulleys. Ascertain that each cable is in the groove of its pulley.
 4. Move the cable guard (4) into position under the pulley cluster (5) that is located in the forward area of the tunnel and secure the guard with cotter pin.
 5. Within the area aft of the main spar, install the cable guard blocks (6) onto the spar housing and secure with screws.
 6. Install the cable guard (7) under the pulley cluster (9) located just aft of the flap torque tube.
 7. Set cable tension and check rigging and adjustment per Paragraph 5-29.
 8. Install the forward tunnel plate aft of the tee bar and secure with screws.
 9. Put the floor carpet in place and secure.
 10. Install the lower and upper selector covers and secure with screws.
 11. Install the rear seat floor panel and install front seats.
- b. The aft rudder control cables may be installed by the following procedure:
 1. Position the control cable in the fuselage.
 2. Connect the end of the cable (14 or 15) to the rudder horn (17) with bolt, washer, nut and cotter pin (16). Allow the cable end free to rotate.
 3. Connect the other cable end to forward control cable (10 or 11) at the turnbuckle (12 or 13) in the aft section of the fuselage.
 4. Set cable tension and check rigging and adjustment per Paragraph 5-29.
 5. Install tail cone fairing and secure with screws.
- c. Install the access panel to the aft section of the fuselage.

5-29. RIGGING AND ADJUSTMENT OF RUDDER CONTROLS.

- a. To check and set the correct degree of rudder travel, the following procedure may be used:
 1. Check the rudder travel by swinging the rudder until it contacts its stops. If the control cables are connected, use the rudder pedals to swing the rudder.
 2. With the rudder against its stop, place a rigging tool against the side of the rudder and vertical stabilizer as shown in Figure 5-11. (Ascertain that the tool is not contacting any rivets.) If no gap exists between the rigging tool and the surface of the rudder and vertical stabilizer, the rudder stop for one direction of travel is correct as required in Table V-I. (This tool may be fabricated from dimensions given in Figure 5-13.)
 3. Swing the rudder in the other direction and check travel as directed in Step 2.
 4. Should the rudder travel be incorrect showing a gap between the tool and any part of the control surfaces, the tail cone fairing should be removed and the stops reset to obtain correct rudder travel. (Refer to Figure 5-13.)
- b. To set cable tension and alignment of the rudder, the following procedure may be used:
 1. Remove the access panel to the aft section of the fuselage.
 2. Ascertain that the nose gear steering has been aligned and rudder pedals set fore and aft according to Alignment of Nose Landing Gear Section VII.
 3. Clamp the rudder pedals to align in a lateral position as shown in Figure 5-12.
 4. Evenly adjust the turnbuckle in the aft section of the fuselage to obtain proper cable tension as given in Table V-I and to allow the rudder to align at neutral position. Neutral position can be determined by standing behind the airplane and sighting the rudder with the vertical stabilizer or the center of the trim screw.

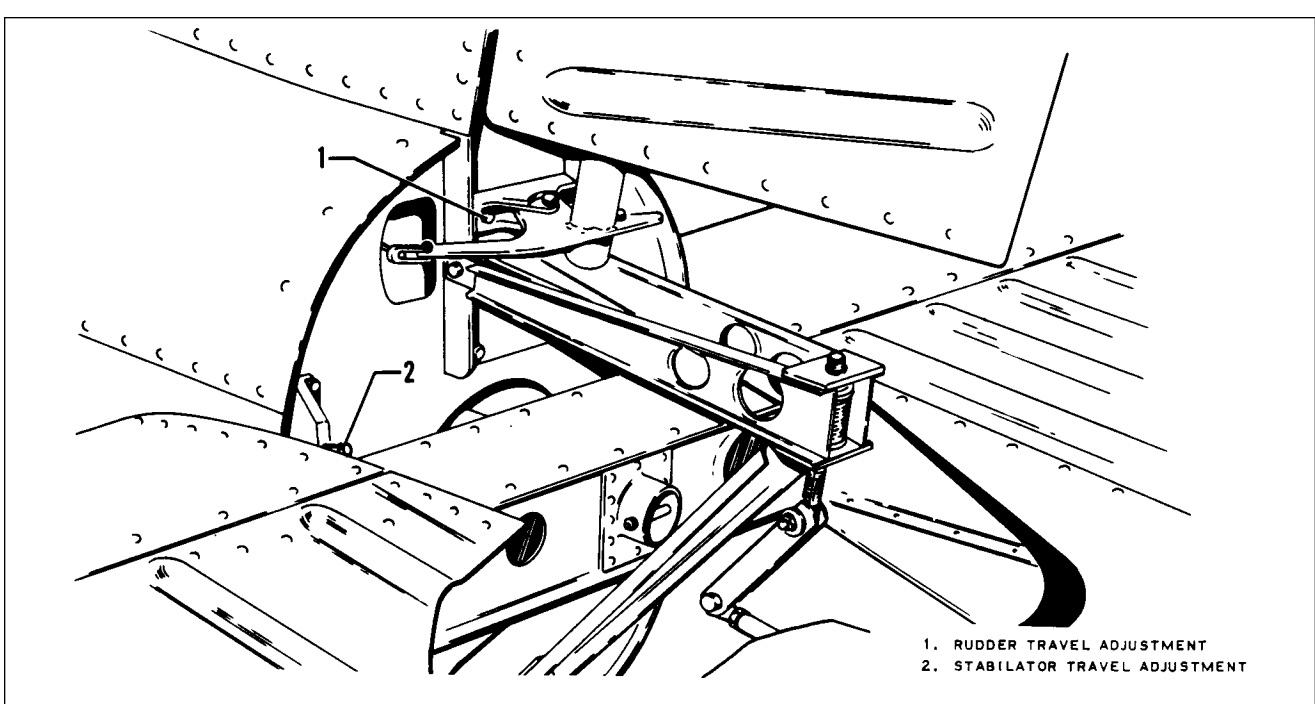

Figure 5-13. Rudder and Stabilator Travel Adjustments

5. Check safety of turnbuckles.
- c. Adjust the rudder pedal stops by pushing on the pilots left rudder pedal until the rudder stop is contacted. Adjust the pedal stop (on the fire wall) to provide 0.060 to 0.120 of an inch clearance. Repeat the procedure with the copilots right rudder pedal. Do not push rudder harder than necessary to avoid cable stretch.
- d. Install the tail cone fairing and the access panel to the aft section of the fuselage.

5-30. RUDDER TRIM CONTROLS.

5-31. REMOVAL OF RUDDER TRIM CONTROLS. (Refer to Figure 5-14.)

- a. Remove the cover (1) from over the trim control assembly by removing attaching screws.
- b. Remove the rudder trim knob (2) and the cover attaching screws.
- c. Rotate the trim knob to the extreme left (counterclockwise) trim position.
- d. Disconnect the housing lug from the arm on the rudder pedal torque tube by removing cotter pin, nut, washer and bolt (7).
- e. Remove the threaded bushing (4) from the aft end of the mounting channel (8) by removing cotter pin and clevis pin (5). Some mounting channels have two holes in the aft end, note from which hole in the clevis pin was removed.
- f. The mounting channel may be removed by removing the channel attaching screws at the inside of the channel.

5-32. INSTALLATION OF RUDDER TRIM CONTROLS. (Refer to Figure 5-14.)

Install the rudder trim mechanism and set it at the neutral (no lead on spring) position. Perform the procedure only after all other rudder and nose wheel rigging is complete.

- a. Install the trim control mounting channel (8) on the upper side of the floor tunnel. A spacer plate (14) on some models is installed between the channel and the tunnel. Install the attaching screws (9) which are secured with anchor nuts.

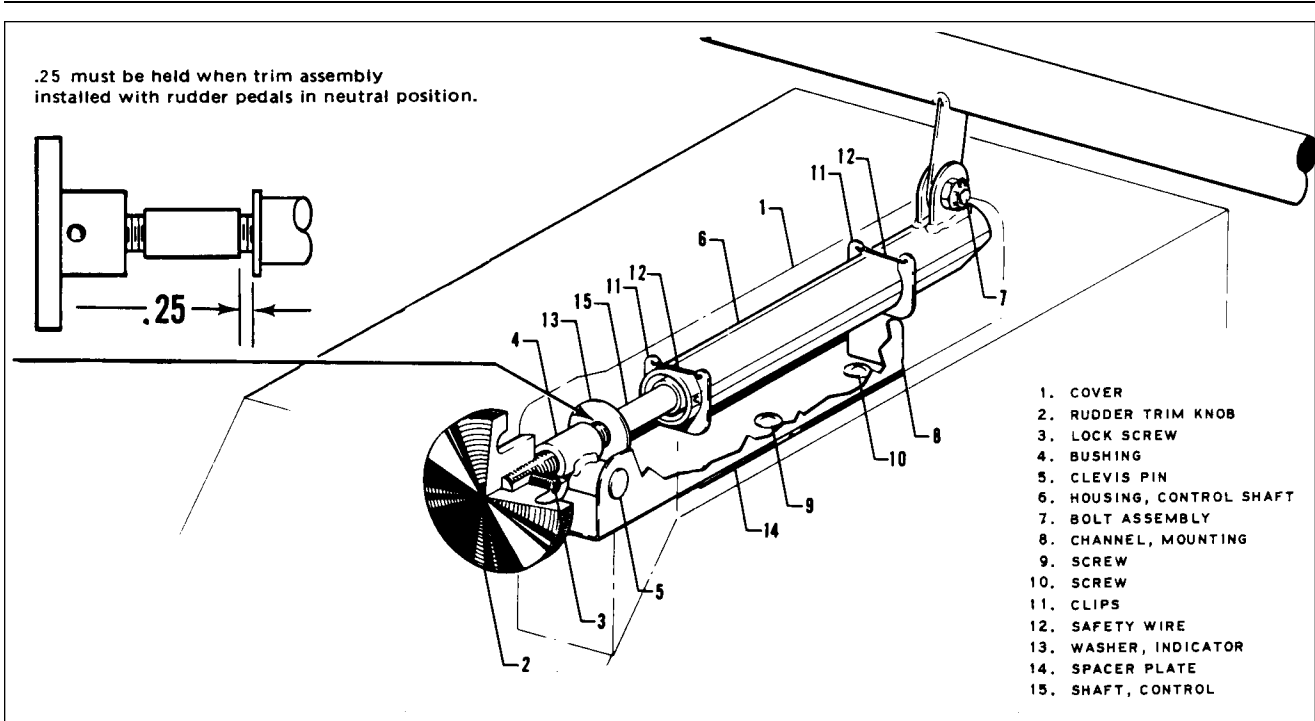

Figure 5-14. Rudder Trim Control

- b. Before attaching the assembly to the mounting channel, ascertain that the clips (11) are installed so the safety wire (12) will be on top. Also, that the threaded bushing (4) is installed on the assembly shaft (15) with the welded attachment bushing forward or toward the housing.
- c. Attach the housing lug to the arm provided on the rudder pedal torque tube and secure with bolt, washer and nut (7). Tighten the nut only finger tight and safety with cotter pin.
- d. Clamp the rudder pedals in neutral and position the threaded bushing in the mounting channel (8). Turn the control shaft until the holes in the bushing and channel align and then install the clevis pin and cotter pin (5). Should two thru holes be located in the aft end of the mounting channel, the pin must be installed through the hole that will give equal travel and hit rudder stops before bottoming out of the trim assembly.
- e. With the rudder pedals neutral and no pressure fore or aft on the clevis pin, install the assembly cover (1) so that the indicator washer (13) and the neutral mark on the cover align.
- f. Install the trim cover, secure with screws, and install the trim control knob.

5-33. RIGGING AND ADJUSTMENT OF RUDDER TRIM CONTROLS. Perform these procedures only after all other rudder and nose wheel rigging is complete. No adjustments are necessary other than those required during installation of the assembly in the airplane as given in Paragraph 5-32.

5-34. WING FLAP CONTROLS.

5-35. REMOVAL OF WING FLAP CONTROLS. (Refer to Figure 5-15.)

- a. The flap torque tube assembly may be removed by the following procedure:
 1. Remove the access plate located between the underside of the aft section of each wing and the fuselage by removing attaching screws.
 2. Remove the two front seats and the rear seat floor panel.

CHEROKEE ARROW III SERVICE MANUAL

3. Disconnect the left and right flap control tubes (rods) (4) at the flaps by removing the nuts, washers and bolts (2) or at the torque tube cranks (arms) (11) by removing the bolts (12) and washers from the inner side of each crank. It will be necessary to remove bolt through a hole in the side skin of the fuselage located over the torque tube with the flap handle moved to its 40 degree position.
 4. With the flap handle (29), fully extend the flaps and disconnect the flap tension spring (22) at the spar or the aft end of the control cable (23), as desired.
 5. Grasp the flap handle, release the plunger (33) and allow the flap to return to the retracted position. Use caution as forward pressure will be on the handle with the tension spring disconnected.
 6. Disconnect the flap return spring (32) at the spar or return chain (30), as desired.
 7. Disconnect the control cable from the chain (20) by removing cotter pin, nut and clevis bolt (21).
 8. Remove the tube support blocks (16 and 31) by removing the block attaching bolts (15).
 9. Remove the nuts, washers and bolts (10) securing the right and left cranks (11) and stop fittings (13) on the torque tube.
 10. From between each wing and the fuselage, remove the cranks from the torque tube.
 11. Disconnect one bearing block (7) from its mounting brackets (6) by removing nuts, washers and bolts (5).
 12. Slide the tube from the bearing block still attached to its brackets; raise the end and lift it from the floor opening.
- b. The flap control cable (23) may be removed by the following procedure:
1. If the front seats and rear seat floor panel have not been removed, remove the seats and floor panel.
 2. Disconnect the flap tension spring (22) from the cable, if not previously disconnected, by extending the flaps to relieve spring tension.
 3. Retract the flap. Use caution as forward pressure will be on the handle with the spring disconnected.
 4. Disconnect the cable from the chain (20) by removing cotter pin, nut, clevis pin and bushing (21).
 5. Remove the flap handle bracket and cover.
 6. Lift the aft section of the tunnel carpet far enough to remove the screws securing the tunnel cover that is between the flap handle and the spar cover. Remove the cover.
 7. Remove the cotter pin cable guard from the flap cable pulley (24) located inside the floor tunnel just ahead of the spar housing.
 8. Remove the cable rub blocks located in the floor opening on the aft side of the spar housing by removing the attaching screws.
 9. Disconnect the cable turnbuckle (25) at the flap handle by removing cotter pin, nut, washer, bushing* and bolt (26). Check clevis bolt (26) for wear. Replace bolt if any wear is evident.
*(See latest revision of Piper Service Bulletin 965.)
- c. Remove the flap handle (29) and bracket (28) by disconnecting the cable turnbuckle from the handle and removing the bolts securing the bracket to the floor tunnel.

5-36. INSTALLATION OF WING FLAP CONTROLS. (Refer to Figure 5-15.)

- a. The flap torque tube assembly may be installed by the following procedure:
 1. Install the chain sprocket (17) with chain (20 and 30) on the torque tube (14) and secure with bolts, washers and nuts (18).
 2. Slide the tube stop fittings (13) on their respective ends of the torque tube.
 3. Ascertain that one bearing block fitting (7) is installed between its attachment brackets (6).
 4. Slide the other bearing block over its respective end of the torque tube.
 5. Position the torque tube by placing the end with the bearing block on it between the mounting bracket and sliding the other end into the previously attached bearing block.
 6. Position the remaining bearing block and secure with bolts, washers and nuts (5).

CHEROKEE ARROW III SERVICE MANUAL

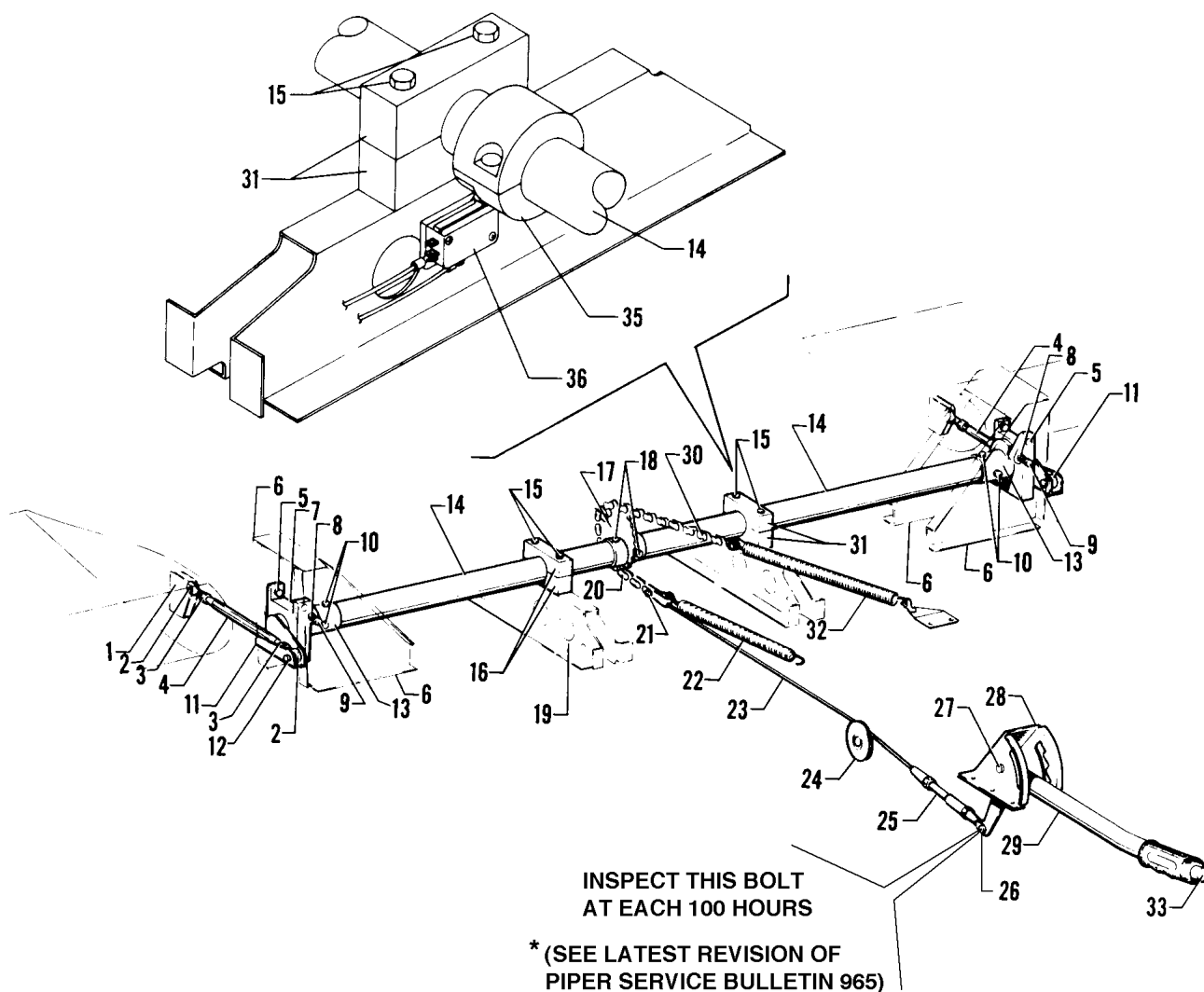

- | | |
|--|---|
| <ul style="list-style-type: none"> 1. BRACKET, ROD ATTACHMENT 2. BOLT, WASHER & NUT 3. JAM NUT 4. ROD, FLAP CONTROL 5. BOLT, BEARING BLOCK ATTACHMENT 6. BRACKET, BEARING BLOCK 7. BLOCK, BEARING 8. NUT, LOCK 9. SCREW, FLAP ADJUSTMENT 10. BOLT, WASHER & NUT 11. CRANK (ARM), TORQUE TUBE 12. BOLT, WASHER & BUSHING 13. FITTING, TORQUE TUBE STOP 14. TUBE, TORQUE 15. BOLT, WASHER & NUT 16. BLOCK, BEARING 17. SPROCKET, TENSION SPRING 18. BOLT, WASHER & NUT | <ul style="list-style-type: none"> 19. BRACKET, BEARING BLOCK 20. CHAIN, TENSION SPRING 21. CLEVIS BOLT, BUSHING NUT & COTTER PIN 22. SPRING, TENSION 23. CABLE, FLAP CONTROL 24. PULLEY 25. TURNBUCKLE 26. CLEVIS BOLT, BUSHING,* WASHER, NUT AND COTTER PIN 27. BOLT, BUSHING, WASHER & NUT 28. BRACKET, FLAP HANDLE 29. HANDLE, FLAP 30. CHAIN, RETURN SPRING 31. BLOCK, BEARING 32. SPRING, RETURN 33. BUTTON, FLAP RELEASE 34. COTTER KEY CABLE GUARD 35. CAM GEAR WARNING 36. GEAR WARNING SWITCH |
|--|---|

Figure 5-15. Flap Controls

CHEROKEE ARROW III SERVICE MANUAL

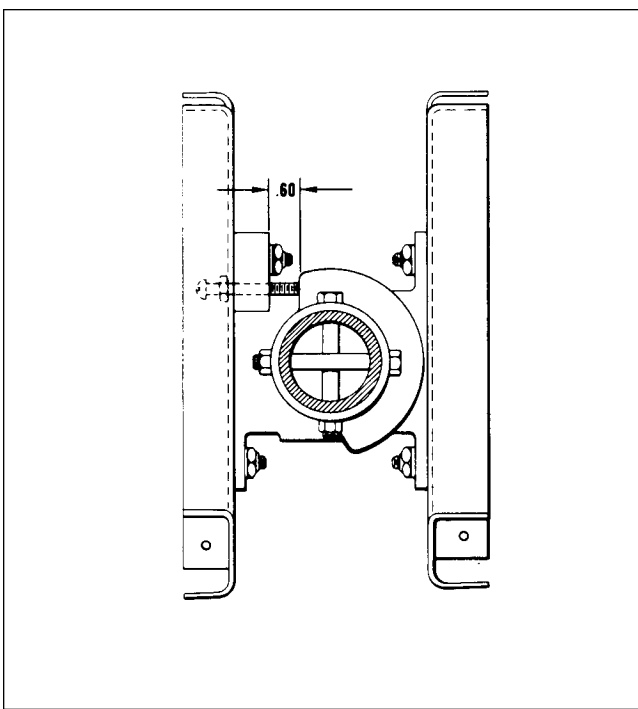

Figure 5-16. Flap Step Adjustment

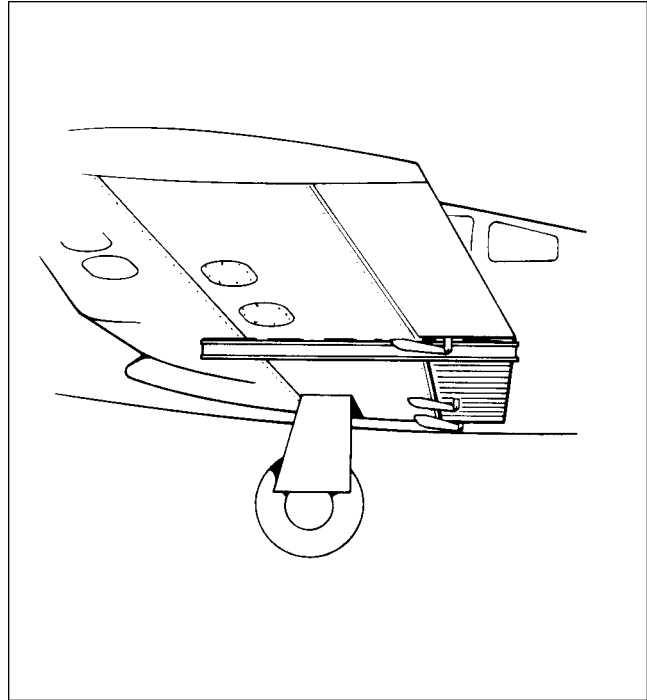

Figure 5-17. Flap Rigging Tool

7. Push the torque tube cranks (arms) (11) on each end of the torque tube and slide the stop fitting (13) in place. Align the bolt hole of the crank and stop fitting with the holes in the torque tube and install bolts. The holes in the stop fitting are longated to allow the stop fitting to be pushed against the bearing blocks (7) thus allowing no side play of the assembly. Tighten the bolt assemblies (10) on the stop fittings.
 8. Install the tube support blocks (16 and 31) on their support brackets (19) and secure with bolts (15).
 9. Connect the flap return spring (32) to the return chain (30) and/or at the spar housing.
 10. Connect the control cable end to the tension chain (20) and secure with bushing, clevis bolt, nut and cotter pin.
 11. Pull the flap handle full back and connect the tension spring (22). Release the flap handle to the forward position.
 12. Connect the flap control tube (4) to the flap and/or torque tube crank (11) and secure. The bolt (12) and bushing that connects the control tube to the crank is installed through a hole in the side of the fuselage located over the torque tube.
- b. To install the flap handle (29) with bracket (28), place the assembly on the floor tunnel and secure with bolts.
 - c. The flap control cable (23) may be installed by the following procedure:
 1. Attach the cable and turnbuckle (25) to the flap handle arm and secure with clevis bolt, bushing*, washer, nut and cotter pin (26). Ascertain that the turnbuckle end is free to rotate on the arm.
*(See latest revision of Piper Service Bulletin 965.)
 2. Route the cable through the tunnel and spar housing.
 3. Install the cable rub blocks on the aft side of the spar housing and secure with screws.
 4. Install cotter pin cable guard over pulley (24) located just ahead of the spar housing in the floor tunnel.

5. Attach the cable end to the tension chain (20) and secure with bushings, clevis bolt, nut and cotter pin. If the chain is not installed because of the torque tube assembly is removed, install the assembly as per Step c instruction. Apply partial tension to cable to keep it positioned on pulley.
6. Install cotter pin cable guard over the pulley (24) which is just ahead of the spar housing in the floor tunnel.
7. Pull the flap handle (29) full back and connect the tension spring (22) to the cable end.
- d. Install the tunnel cover and secure with screws. Also, install the tunnel carpet and bracket cover.
- e. Install and secure the seats.

5-37. RIGGING AND ADJUSTMENT OF WING FLAPS.

- a. Place the flap control lever in the full forward (flaps up) position.
- b. Remove rear seats and floorboard to gain access to the flap torque tube.
- c. To adjust the flap up stop and step lock, first back off the left torque tube stop screw.
- d. Adjust the right torque stop screw to obtain approximately 0.60 inch between the stop fitting and the bearing back. (Refer to Figure 5-16.)
- e. With 0.60 inch obtained, and the right stop screw against its stop, tighten the lock nut, securing the stop screw.
- f. Adjust the left stop screw to make contact with the left stop.
- g. Adjust the left upper tension spring, chain and cable. With the flap handle in the "flaps up" full forward position, adjust the turnbuckle to remove all slack. Do not tighten cable to a point that the stop screw comes off the stop.
- h. Install the lower tension spring with the flap handle in the "flaps fill down" position.
- i. Place a 0.125 inch spacer between the right stop screw and stop fitting. With the right flap installed and its flap control rod connected, determine that while exerting "down" pressure on the top of the flap will not allow the flap to come down. If the flap extends, turn the stop screw out until "down" pressure on the top of the flap will not allow the flap to go down.
- j. Adjust the left stop screw to match the right, then tighten its lock nut and remove the 0.125 inch spacer.
- k. To set the flap control tension, remove the flap handle cover and tunnel access cover. Set the flap control handle to the 0 degree position (handle forward, next to floor). Adjust the turnbuckle in the tunnel to obtain 10 lb. +/- 1 lb. tension on the cable as per instructions given in Table V-I. When this operation is completed, safety the turnbuckle.

NOTE

Do not rotate the torque tube, or allow the tube to be pulled away from the stops in any way, when tensioning the cable.

1. With the flap handle in the "flaps up" position, check the up-neutral position by placing the flap rigging tool (shown in Figure 5-17) against the bottom of the wing and each flap at a point as close as possible to the outboard end of the flap. Ensure that the tool is not contacting any rivets. This tool may be fabricated firm dimension data given in Figure 5-19.)
- m. Adjust both flap push rods, which are connected between the right and left end of the torque tube and each flap, until contact is made between the surface of the wing and the forward surface to the tool, and the trailing edge of the flap is in contact with the aft end of the tool, so that the chord line of the flaps form a +/- 1 degree angle with the wing chord at the outboard end of the flap(s). Maintain a light "up" pressure on the underside of the flap (sufficient to take the slack out of the linkage) while adjusting the rods.
- n. Check the flap operation to the degree figures required in Table V-I. They should be 10 +/- 2 degrees for the first notch, 25 +/- 2 degrees for the second notch, and 40 +/- 2 degrees for the third notch. If for any reason, the settings cannot be obtained, then the torque tube stop screws will require readjustments, and a review of the entire procedure. When a check of the flap operation is complete, then install all access plates, and panels.

NOTE

In the event of wing heaviness during flight, the flap on the side of the heavy wing can be adjusted down from neutral to remedy this condition by lengthening the control rod. Check the inspection hole in each rod end to ascertain that there are sufficient threads remaining and a wire cannot be inserted through these holes. Rod ends without check holes, maintain a minimum of .375 of an inch thread engagement. Do not raise the flap of the other wing above neutral.

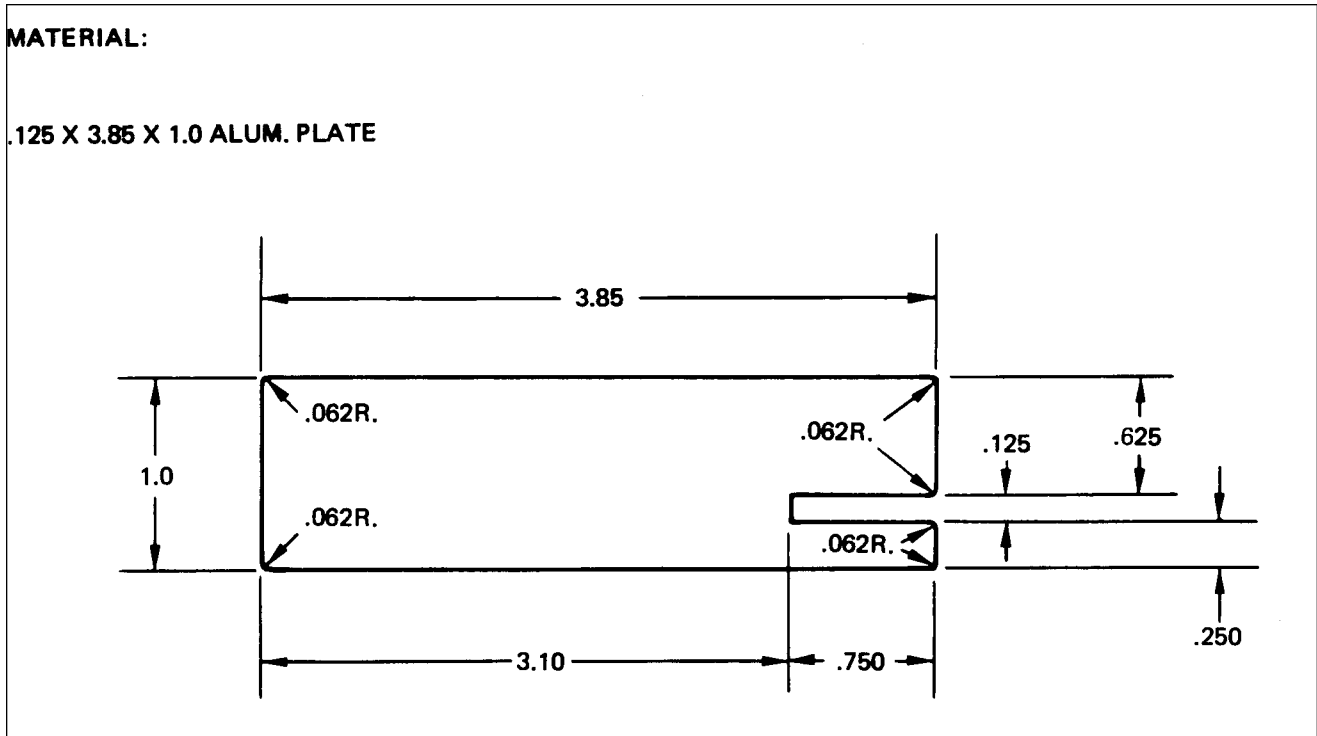

Figure 5-18. Fabricated Aileron Bellcrank Rigging Tool

MATERIAL:
.750 X 31.50 X 4.00 ALUM. BAR

NOTE:
1. DRILL AND TAP TO 1/4-28NF. BOLT AND FILE TO REQUIRED LENGTH.
2. SPAR STOCK MAY BE USED IN PLACE OF ALUM. BAR STOCK.

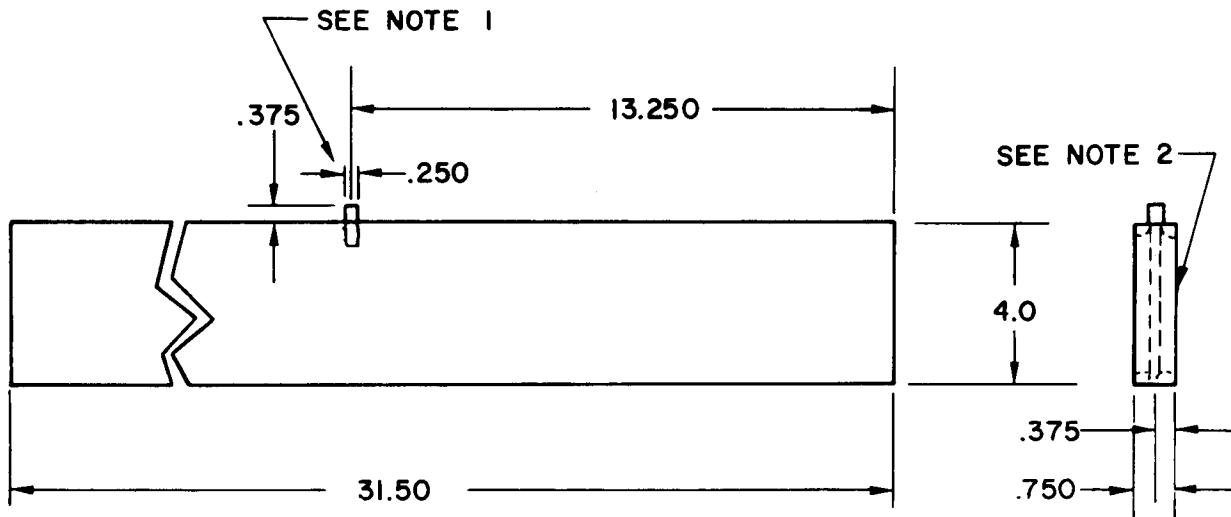

Figure 5-19. Fabricated Aileron and Flap Rigging Tool

*** CHEROKEE ARROW III SERVICE MANUAL**

**MATERIAL:
1.0 X 23.19 X 3.82 ALUM. BAR**

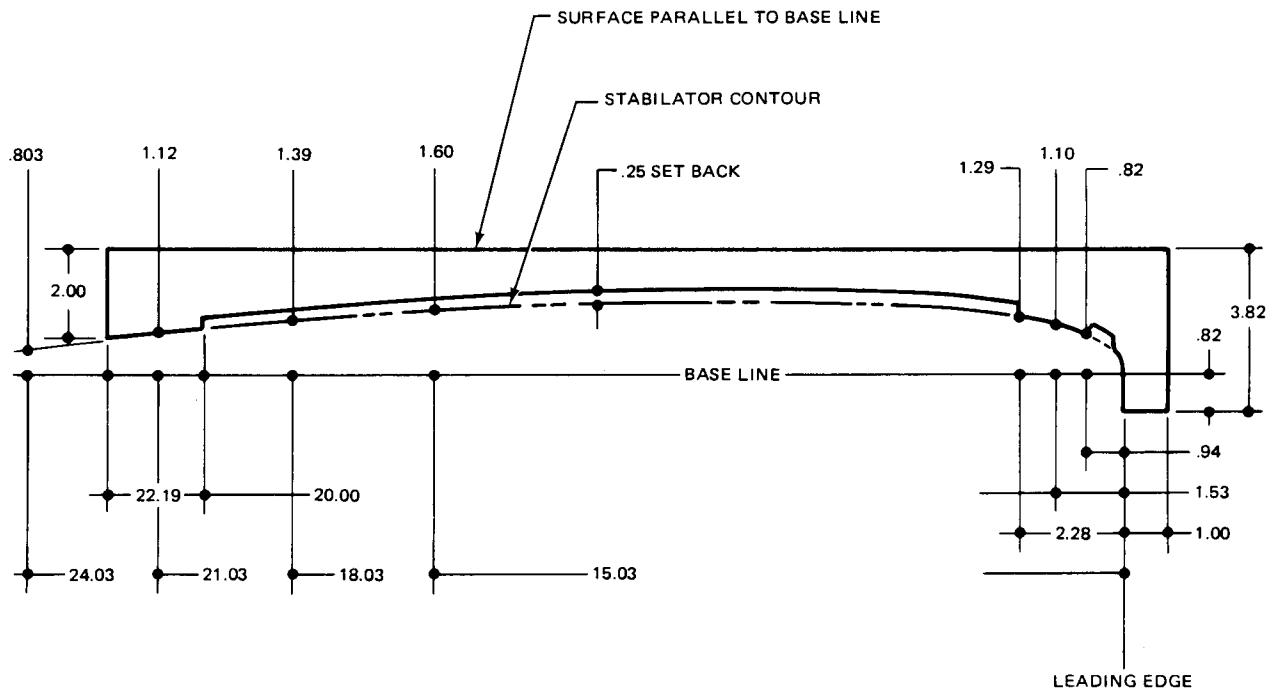

Figure 5-20. Fabricated Stabilator Rigging Tool

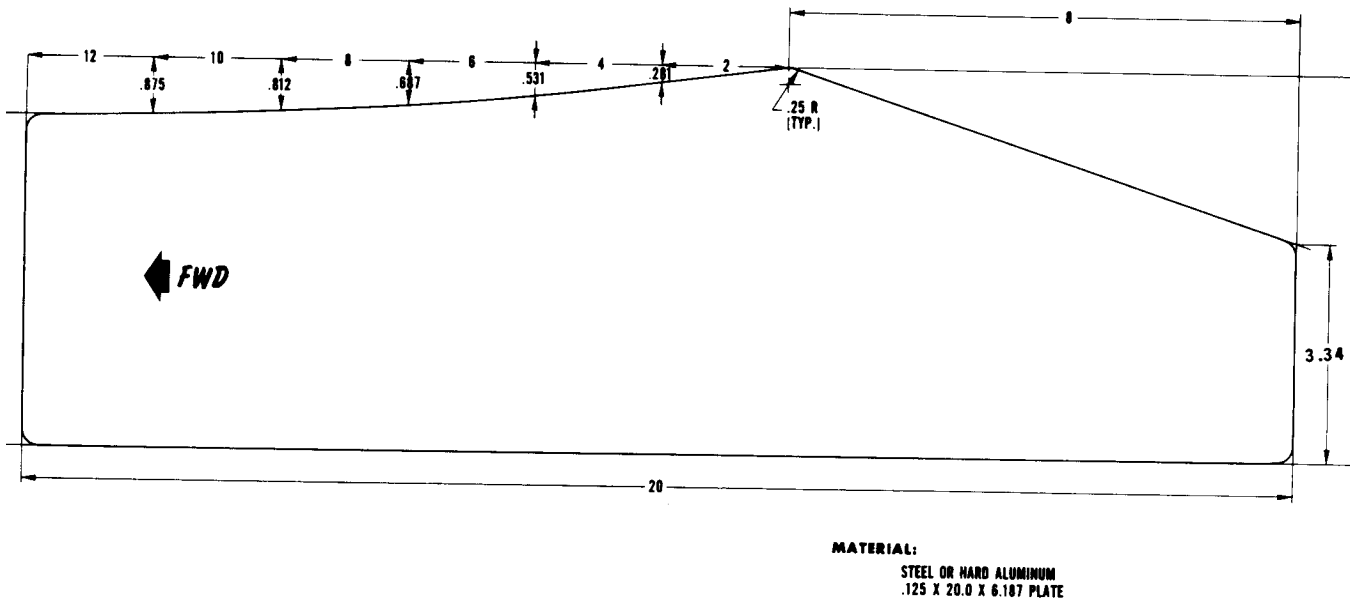

Figure 5-21. Fabricated Rudder Rigging Tool

CHEROKEE ARROW III SERVICE MANUAL

TABLE V-III. TROUBLESHOOTING CHART (SURFACE CONTROLS)

Trouble	Cause	Remedy
AILERON CONTROL SYSTEM		
Lost motion between control wheel and aileron.	Cable Tension too low.	Adjust cable tension. (Refer to Paragraph 5-12.)
	Linkage loose or worn.	Check linkage and tighten or replace.
	Broken pulley.	Replace pulley.
	Cables not in place on pulleys.	Install cables correctly. Check cable guards.
Resistance to control wheel rotation.	System not lubricated properly.	Lubricate system.
	Cable tension too high.	Adjust cable tension. (Refer to Paragraph 5-12.)
	Control column horizontal chain improperly adjusted.	Adjust chain tension. (Refer to Paragraph 5-6.)
	Pulleys binding or rubbing.	Replace binding pulleys and/or provide clearance between pulleys and brackets.
	Cables not in place on pulleys.	Install cables correctly. Check cable guards.
	Bent aileron and/or hinge.	Repair or replace aileron and/or hinge.
	Cables crossed or routed incorrectly.	Check routing of control cables.

CHEROKEE ARROW III SERVICE MANUAL

TABLE V-III. TROUBLESHOOTING CHART (SURFACE CONTROLS) (cont.)

Trouble	Cause	Remedy
STABLIATOR CONTROL SYSTEM (cont.)		
Resistance to stabilator control movement.	<p>System not lubricated properly.</p> <p>Cable tension too high.</p> <p>Binding control column.</p> <p>Pulleys binding or rubbing.</p> <p>Cables not in place on pulleys.</p> <p>Cables crossed or routed incorrectly.</p> <p>Bent stabilator hinge.</p>	<p>Lubricate system.</p> <p>Adjust cable tension per Paragraph 5-16.</p> <p>Adjust and lubricate per Paragraph 5-6.</p> <p>Replace binding pulleys and/or provide clearance between pulleys and brackets.</p> <p>Install cables correctly.</p> <p>Check routing of control cables.</p> <p>Repair or replace stabilator hinge.</p>
Incorrect stabilator travel.	Stabilator stops incorrectly adjusted.	Adjust stop screws per Paragraph 5-16.
Correct stabilator travel cannot be obtained by adjusting stops.	Stabilator cables incorrectly rigged.	Rig cables in accordance with Paragraph 5-16.

CHEROKEE ARROW III SERVICE MANUAL

TABLE V-III. TROUBLESHOOTING CHART (SURFACE CONTROLS) (cont.)

Trouble	Cause	Remedy
AILERON CONTROL SYSTEM (cont.)		
Control wheels not synchronized.	Incorrect control column rigging.	Rig in accordance with Paragraph 5-6.
Control wheels not horizontal when ailerons are neutral.	Incorrect rigging of aileron system.	Rig in accordance with Paragraph 5-12.
Incorrect aileron travel.	Aileron control rods not adjusted properly.	Adjust in accordance with Paragraph 5-12.
	Aileron bellcrank stops not adjusted properly.	Adjust in accordance with Paragraph 5-12.
Correct aileron travel cannot be obtained by adjusting bellcrank stops.	Incorrect rigging of aileron cables, control wheel and control rod.	Rig in accordance with Paragraph 5-12.
Control wheel stops before control surfaces reach full travel.	Incorrect rigging between control wheel and control cables.	Rig in accordance with Paragraph 5-12.
STABILATOR CONTROL SYSTEM		
Lost motion between control wheel and stabilator.	Cable tension too low.	Adjust cable tension per Paragraph 5-16.
	Linkage loose or worn.	Check linkage and tighten or replace.
	Broken pulley.	Replace pulley.
	Cables not in place on pulleys.	Install cables correctly.

CHEROKEE ARROW III SERVICE MANUAL

TABLE V-III. TROUBLESHOOTING CHART (SURFACE CONTROLS) (cont.)

Trouble	Cause	Remedy
STABILATOR TRIM CONTROL SYSTEM		
<p>Lost motion between trim control wheel and trim tab.</p>	<p>Cable tension too low.</p>	<p>Adjust in accordance with Paragraph 5-22.</p>
	<p>Cables not in place on pulleys.</p>	<p>Install cables according to Paragraphs 5-19 and 5-21.</p>
	<p>Broken pulley.</p>	<p>Replace pulley.</p>
	<p>Linkage loose or worn.</p>	<p>Check linkage and tighten or replace.</p>
<p>Trim control wheel moves with excessive resistance.</p>	<p>System not lubricated properly.</p>	<p>Lubricate system.</p>
	<p>Cable tension too high.</p>	<p>Adjust in accordance with Paragraph 5-22.</p>
	<p>Pulleys binding or rubbing.</p>	<p>Replace binding pulleys. Provide clearance between pulleys and brackets.</p>
	<p>Cables not in place on pulleys.</p>	<p>Refer to Paragraphs 5-19 and 5-21.</p>
	<p>Trim tab hinge binding.</p>	<p>Lubricate hinge. If necessary, replace.</p>
	<p>Cables crossed or routed incorrectly.</p>	<p>Check routing of control cables.</p>

CHEROKEE ARROW III SERVICE MANUAL

TABLE V-III. TROUBLESHOOTING CHART (SURFACE CONTROLS) (cont.)

Trouble	Cause	Remedy
STABILATOR TRIM CONTROL SYSTEM (cont.)		
Trim tab fails to reach full travel.	<p>System incorrectly rigged.</p> <p>Trim drum incorrectly wrapped.</p>	<p>Check and/or adjust rigging per paragraph 5-22.</p> <p>Check and/or adjust rigging per paragraph 5-22.</p>
Trim indicator fails to indicate correct trim position.	Trim indicator unit not adjusted properly.	Adjust in accordance with Paragraph 5-22.
RUDDER CONTROL SYSTEM		
Lost motion between rudder pedals and rudder.	<p>Cable tension too low.</p> <p>Linkage loose or worn</p> <p>Broken pulley.</p> <p>Bolts attaching rudder to bellcrank are loose.</p>	<p>Adjust cable tension per Paragraph 5-29.</p> <p>Check linkage and tighten or replace.</p> <p>Replace pulley.</p> <p>Tighten bellcrank bolts.</p>
Excessive resistance to rudder pedal movement.	<p>System not lubricated properly.</p> <p>Rudder pedal torque tube bearing in need of lubrication.</p> <p>Cable tension too high.</p>	<p>Lubricate system.</p> <p>Lubricate torque tube bearings.</p> <p>Adjust cable tension Per Paragraph 5-29.</p>

CHEROKEE ARROW III SERVICE MANUAL

TABLE V-III. TROUBLESHOOTING CHART (SURFACE CONTROLS) (cont.)

Trouble	Cause	Remedy
RUDDER CONTROL SYSTEM (cont.)		
Excessive resistance to rudder pedal movement. (cont.)	<p>Pulleys binding or rubbing.</p> <p>Cables not in place on pulleys.</p> <p>Cables crossed or routed incorrectly.</p>	<p>Replace binding pulleys and/or provide clearance between pulleys and brackets.</p> <p>Install cables correctly. Check cable guards.</p> <p>Check routing of control cables.</p>
Rudder pedals not neutral when rudder is streamlined.	Rudder cables incorrectly rigged.	Rig in accordance with Paragraph 5-29.
Incorrect rudder travel.	<p>Rudder bellcrank stop incorrectly adjusted.</p> <p>Nose wheel contacts stops before rudder.</p>	<p>Rig in accordance with Paragraph 5-29.</p> <p>Rig in accordance with Paragraph 5-29.</p>
RUDDER TRIM CONTROL SYSTEM		
Trim control knob moves with excessive resistance.	System not lubricated properly.	Lubricate system.
FLAP CONTROL SYSTEM		
Flaps fail to extend or retract.	Control cable broken or disconnected.	Replace or reconnect control cable. (Refer to Paragraph 5-36.)

CHEROKEE ARROW III SERVICE MANUAL

TABLE V-III. TROUBLESHOOTING CHART (SURFACE CONTROLS) (cont.)

Trouble	Cause	Remedy
FLAP CONTROL SYSTEM (cont.)		
Flaps not synchronized or fail to move evenly when retracted.	Incorrect rigging of system.	Adjust flaps per instructions in Paragraph 5-37.

IH3
INTENTIONALLY LEFT BLANK

IH4
INTENTIONALLY LEFT BLANK

SECTION VI

HYDRAULIC SYSTEM

Paragraph		Aerofiche Grid No.
6-1.	Introduction	1H6
6-2.	Description	1H6
6-3.	Troubleshooting.....	1H7
6-4.	Hydraulic Pump.....	1H10
	6-5. Removal of Hydraulic Pump.....	1H10
	6-6. Disassembly of Hydraulic Pump	1H10
	6-7. Cleaning, Inspection and Repairs of Hydraulic Pump	1H11
	6-8. Assembly of Hydraulic Pump	1H11
	6-9. Test and Adjustment of Hydraulic Pump.....	1H14
	6-10. Installation of Hydraulic Pump.....	1H16
6-11.	Gear Back-Up Extender Actuator Assembly.....	1H16
	6-12. Removal of Gear Back-Up Extender Actuator Assembly	1H16
	6-13. Installation of Gear Back-Up Extender Actuator Assembly.....	1H17
	6-14. Check and Adjustment of Gear Back-Up Extender Actuator.....	1H19
	6-14a. Operational Check of Retractable Landing Gear System	1H21
6-15.	Nose Gear Actuating Cylinder	1H24
	6-16. Removal of Nose Gear Actuating Cylinder	1H24
	6-17. Disassembly of Nose Gear Actuating Cylinder.....	1H24
	6-18. Cleaning, Inspection and Repair of Nose Gear Actuating Cylinder	1H24
	6-19. Assembly of Nose Gear Actuating Cylinder.....	1H24
	6-20. Installation of Nose Gear Actuating Cylinder	1H1
6-21.	Main Gear Actuating Cylinder.....	1H1
	6-22. Removal of Main Gear Actuating Cylinder	1H1
	6-23. Disassembly of Main Gear Actuating Cylinder	1H3
	6-24. Cleaning, Inspection, and Repair of Main Gear Actuating Cylinder	1H3
	6-25. Assembly of Main gear Actuating Cylinder	1H3
	6-26. Installation of Main Gear Actuating Cylinder	1H3
6-27.	Hydraulic Lines	1H3
	6-28. Removal and Installation of Hydraulic Lines.....	1H3
6-29.	Testing Hydraulic System	1H4
6-30.	Servicing Hydraulic Pump/Reservoir	1H4

SECTION VI

HYDRAULIC SYSTEM

6-1. INTRODUCTION. The hydraulic system components covered in this section consist of the combination hydraulic pump and reservoir (both Prestolite and Oildyne), gear back-up extender actuator assembly (if operational), actuating cylinders and hydraulic lines. The brake system, although hydraulically operated, is not included in this section because it incorporates its own hydraulic system which is independent of the gear retraction system. The brake system along with the landing gear and components are covered in Section VII.

This section provides instructions for remedying problems which may arise in the operation of the hydraulic system. The instructions are organized so that the mechanic can refer to: Description of the System, for a basic understanding of the system; Troubleshooting, for a methodical approach in locating problems; Corrective Maintenance, for the removal, repair and installation of components; Adjustments and Checks, for the operation of the repaired system.

CAUTION

Prior to any investigation of the hydraulic system, properly place the airplane on jacks. (Refer to Jacking, Section II.)

6-2. DESCRIPTION. Hydraulic fluid is supplied to the landing gear actuating cylinders by an electrically powered reversible pump located aft of the baggage compartment at right side station 156.00. There are two vendors that supply pumps that are incorporated in the PA-28R-201/201T airplane. One pump, which has been installed in Piper airplanes for years is the Prestolite. The latest that has been installed, is the Oildyne. Both are interchangeable, and are similar in that they both have reservoirs that are an integral part of the pump. Both pumps are controlled by a selector handle located on the instrument panel to the left of the control quadrant. As the handle is selected to either the up or down position, the pump directs fluid through a single line to a manifold and from that manifold to each individual actuating cylinder. As fluid pressure increases at one side of a cylinder piston, fluid at the opposite side is directed back through another manifold to the pump reservoir. The two manifolds and their connecting lines serve either as pressure or return passages depending on the rotation of the pump to retract or extend the gear.

On the manifold through which pressured fluid passes during gear retraction, there is located a pressure switch which opens the electrical circuit to the pump solenoid when the gear fully retracts and pressure in the system increases to 1800 plus or minus 100 psi. The switch will continue to hold the circuit open until pressure in the system drops to 1500 plus or minus 100 psi, which at this point the pump will again operate to build up the pressure as long as the gear selector handle is in the up position. The down position of the gear handle has no effect on the pressure switch

The hydraulic pump is a gear type unit driven by a 14 volt reversible motor. To prevent excessive pressure on the hydraulic system due to fluid expansion, there is a thermal relief valve incorporated in the Prestolite pump that will open at 2250 plus or minus 250 psi, and the Oildyne pump at 3000 plus 300 or minus 200 psi, thus allowing fluid to flow to the pump reservoir. Other valves in the pump system channel fluid to the proper outlets during gear retraction or extension. In the base of the pump is a shuttle valve that allows fluid displaced by the cylinder piston rods to return to the reservoir without back pressure. This shuttle valve has a delivery pressure of 400 to 800 psi during the extension cycle.

Also in the system is a bypass or free-fall valve that allows the gear to drop should a malfunction in the pump circuit occur. To prevent the gear from extending too fast, there is a special restrictor fitting on the side of the valve. If your particular hydraulic system has the gear back-up extension device operation (refer to Piper Service Bulletin 886A), this valve will operate one of two ways. First, manually by pushing the emergency gear lever located on the forward center floor console between the front seats to the left of the flap handle, to "Emergency Down" position. This method is the only way that the gear can be extended in an emergency if you have complied with Piper Service Bulletin 886A. The second way of operating the free-fall valve is that if you have not complied with Piper Service Bulletin 886A and opted to keep your gear back-up extension system operational, the first method will apply, along with the operation of a pressure sensing device incorporated in the back-up extension system. This pressure sensing device incorporated in the gear back-up extension system which lowers the gear regardless of gear selector handle position, depends upon airspeed and engine power (propeller slipstream). Gear extension occurs even if the selector is in the up position, at airspeed below approximately 103 KIAS for the PA-28R-201T or 95 EUAS for PA-28R-201 with engine idled or in power off. The device also prevents the gear from retracting at airspeed below approximately 78 KIAS for PA-28R-201T or 75 KIAS for PA-28R-201 with full power, though the selector switch may be in the up position. This speed increases with reduced power and/or increases altitude. The sensing device operation is controlled by a differential air pressure across a flexible diaphragm which is mechanically linked to the hydraulic valve and an electrical switch which actuates the pump motor. A high pressure and static air source for actuating the diaphragm is provided in a mast mounted on the left side of the fuselage above the wing.

The emergency gear lever, used for emergency extension of the gear, manually releases hydraulic pressure to permit the gear to "free-fall" with spring assistance on the nose gear. The lever must be held in the downward position for emergency extension. This same lever when held in the up position, can be used to override the system, and gear position is controlled by the gear selector switch regardless of airspeed power combinations. The lever must also be held in the raised position when hydraulic system operational checks are being conducted. An override lock allows the emergency extension lever to be locked in the up override position. A warning light is mounted below the gear selector lever and flashes to indicate whenever the lock is in use. The lock is disengaged by pulling up on the extension lever.

For a description of the landing gear and electrical switches, refer to Section VII, Landing Gear and Brake System.

6-3. TROUBLESHOOTING. Malfunctions of the hydraulic system obviously will result in failure of the landing gear to operate properly. When problems occur, jack the airplane up (refer to Jacking, Section II) and then proceed to determine the extent of the problem. Generally, hydraulic system problems fall into two types; problems involving the hydraulic supplying system and problems in the landing gear hydraulic system. Table VI-III at the back of this section, lists the problems which may be encountered and their probable cause and suggestions to remedy the problem involved. A hydraulic system operational check may be conducted using Figure 6-1 or 6-2. When the problem has been recognized, the first step in troubleshooting is to isolate the cause. Hydraulic system problems are not always traceable to one cause. It is possible that a malfunction may result of more than one difficulty within the system. Starting first with the obvious and most probable reasons for the problem, check each possibly in turn and by process of elimination, isolate the problems.

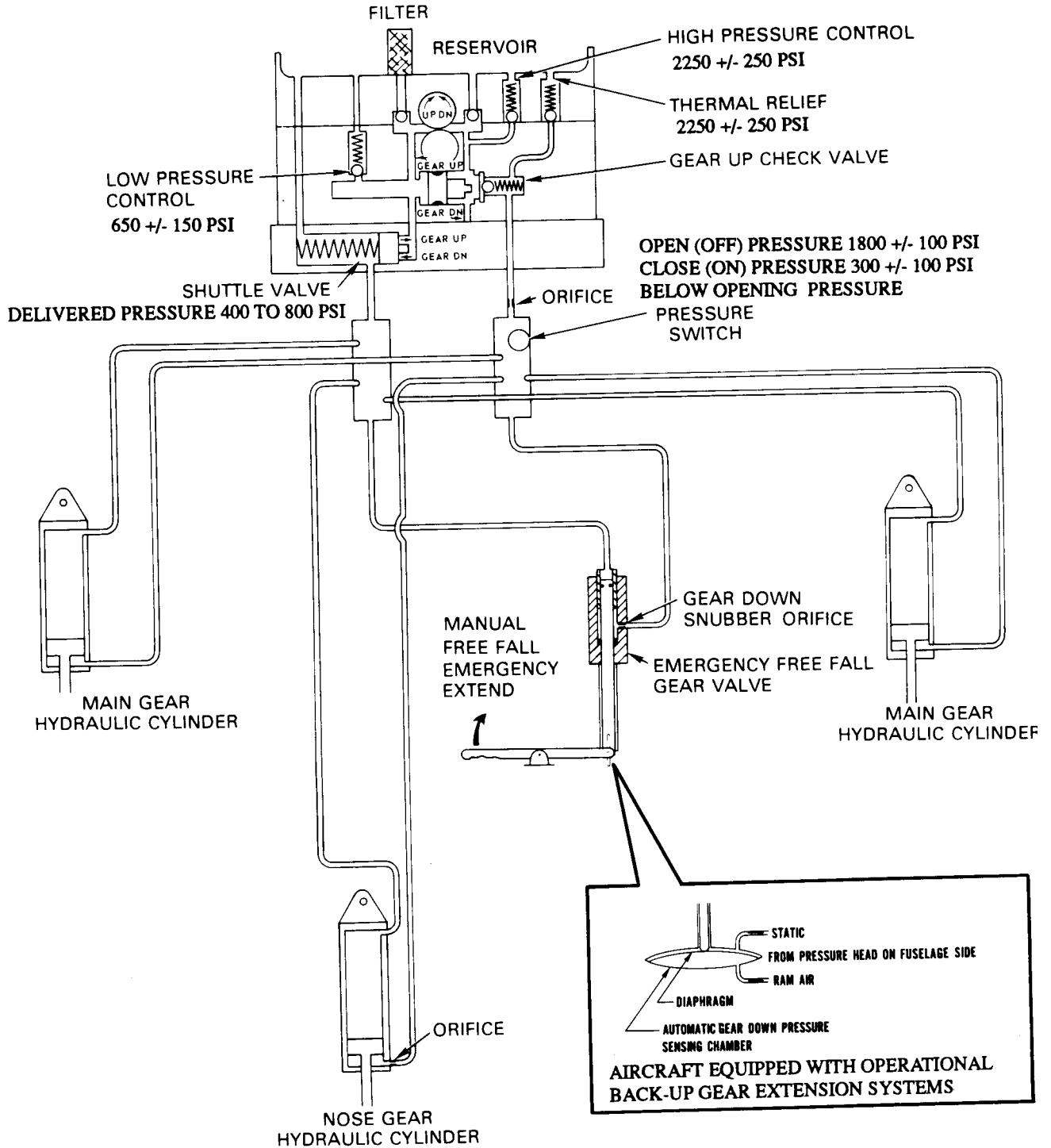

Figure 6-1. Schematic Diagram of Hydraulic System (Prestolite)

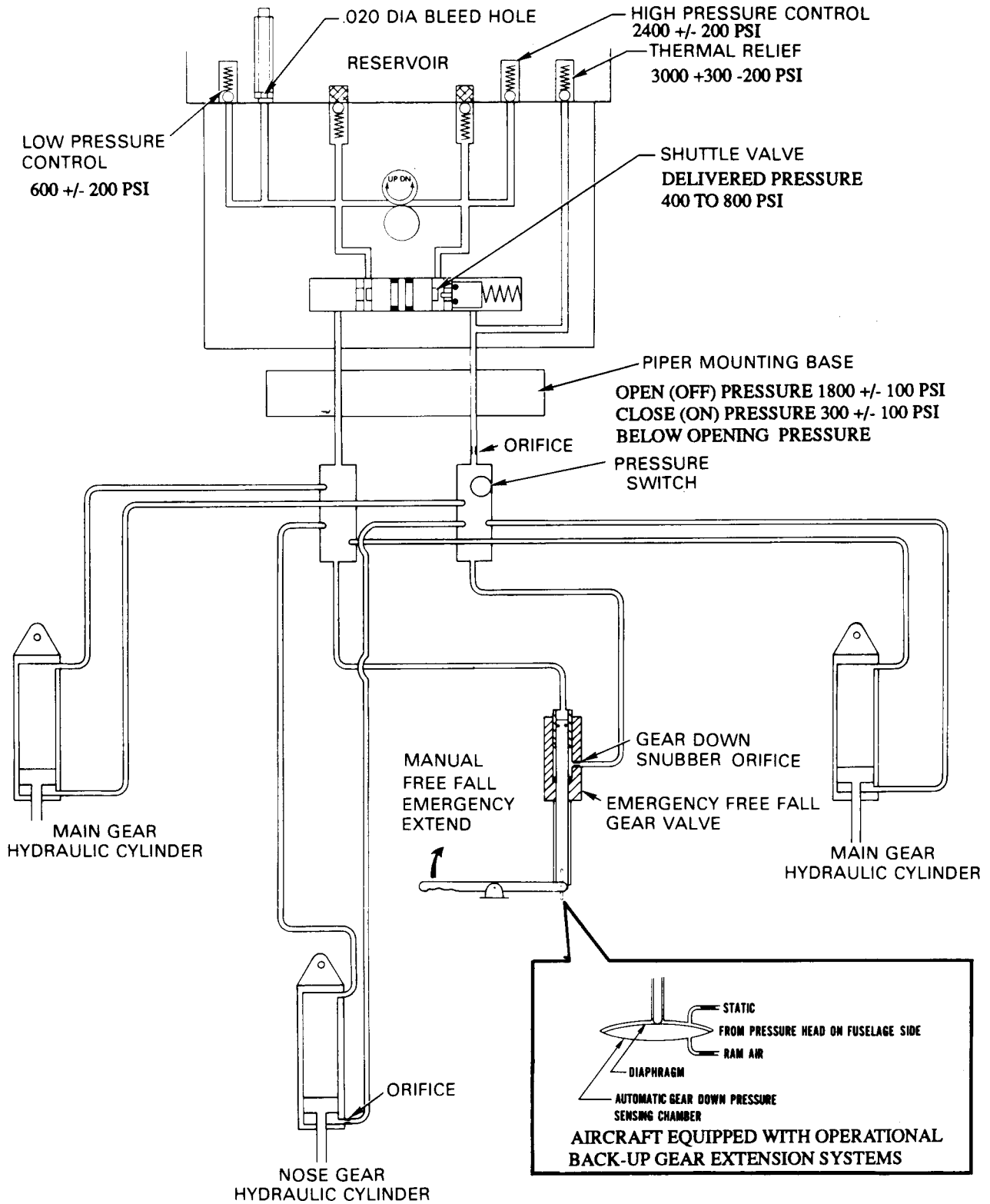
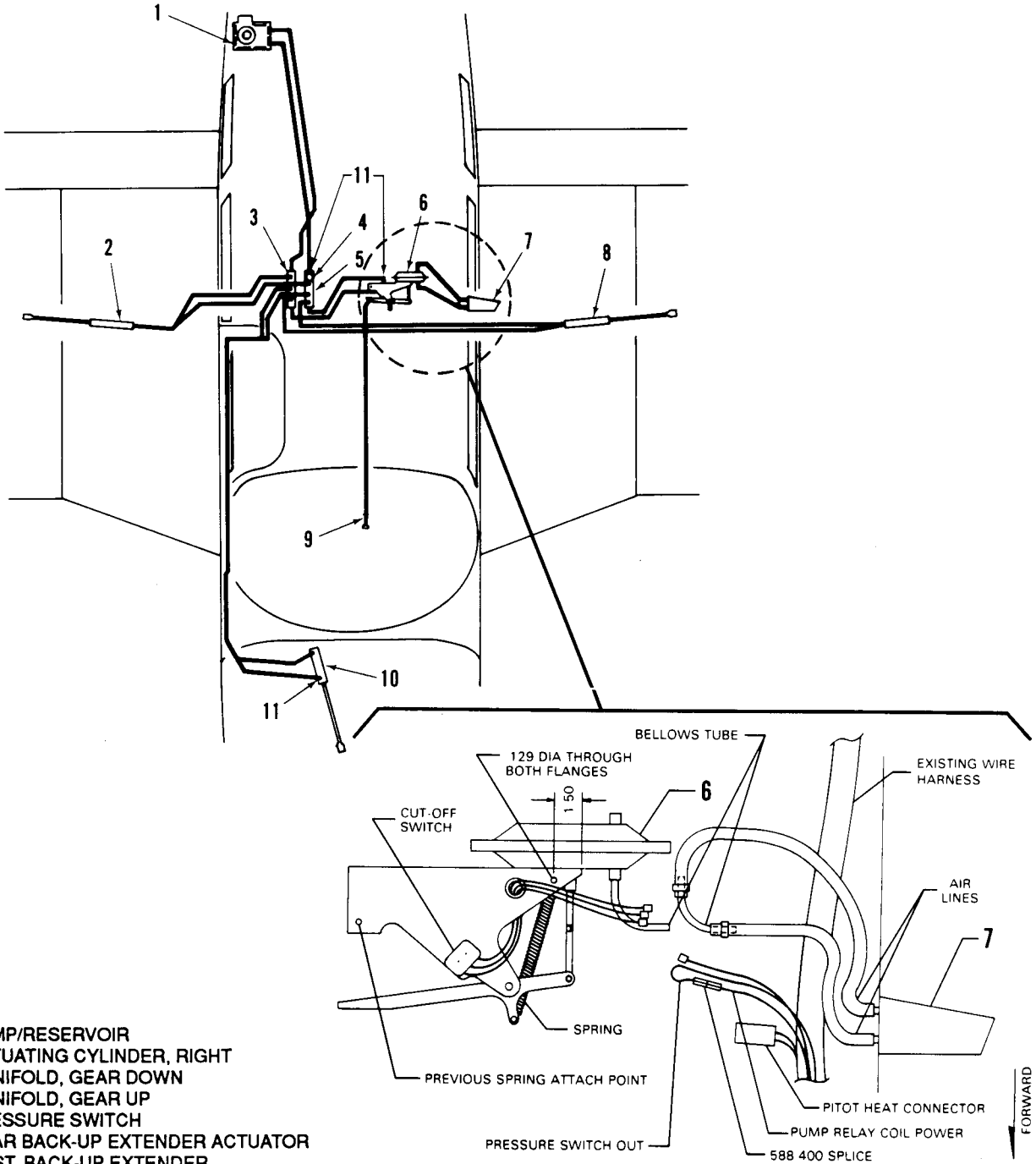

Figure 6-1a. Schematic Diagram of Hydraulic System (Oilydne)



1. PUMP/RESERVOIR
2. ACTUATING CYLINDER, RIGHT
3. MANIFOLD, GEAR DOWN
4. MANIFOLD, GEAR UP
5. PRESSURE SWITCH
6. GEAR BACK-UP EXTENDER ACTUATOR
7. MAST, BACK-UP EXTENDER
8. ACTUATING CYLINDER, LEFT
9. LEVER, EMERGENCY EXTENDER
10. ACTUATING CYLINDER NOSE
11. FITTING, RESTRICTOR

DISABLED VIEW PER INSTRUCTIONS
PIPER SERVICE BULLETIN 866A

Figure 6-2. Hydraulic System Installation

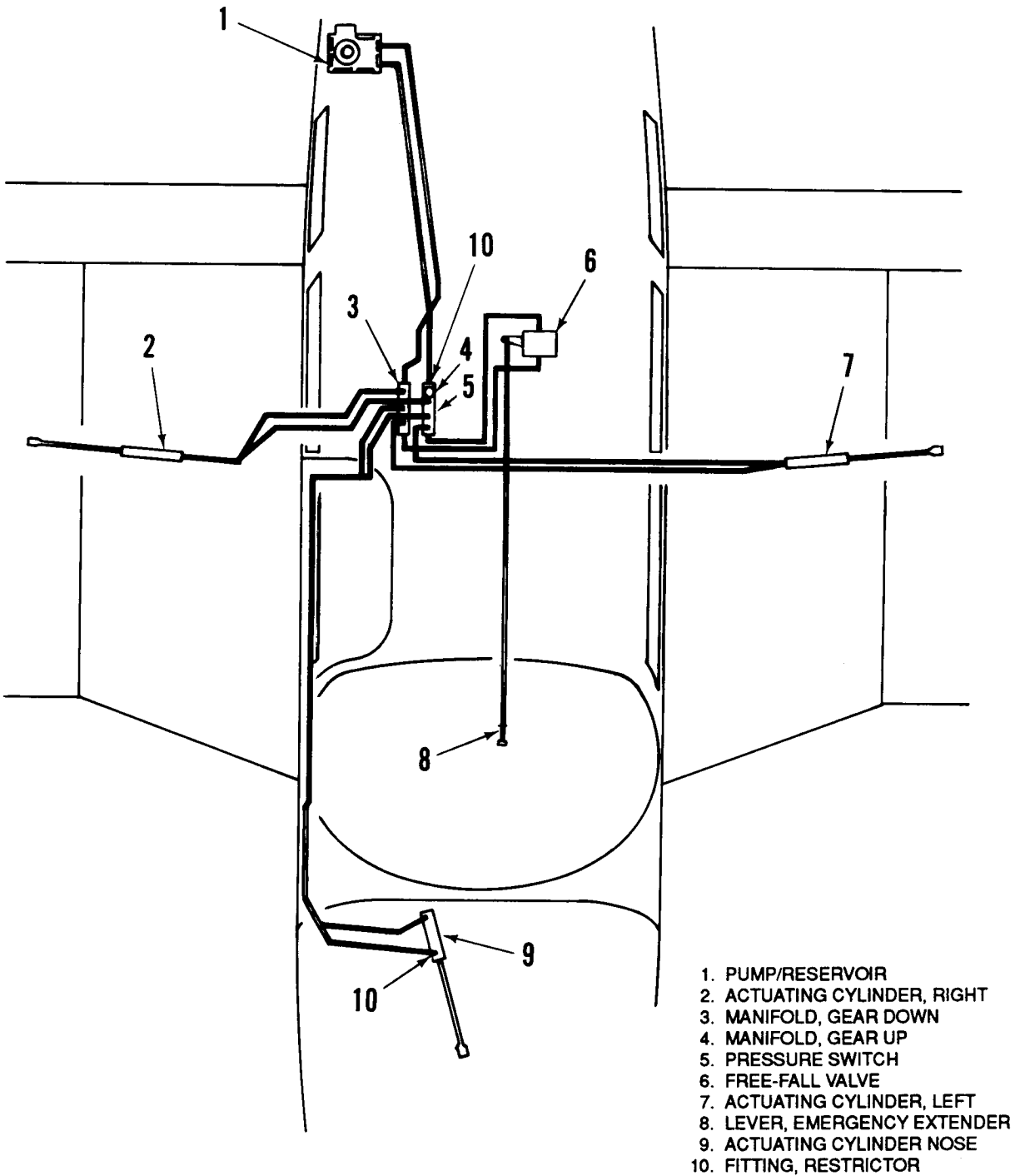

Figure 6-2a. Hydraulic System Installation
S/N's 2837001 (PA-28R-201) and Up, and S/N's 2803001 (PA-28R-201T) and Up

*** CHEROKEE ARROW III SERVICE MANUAL**

TABLE VI-I. LEADING PARTICULARS, HYDRAULIC SYSTEM

Hydraulic	PRESTOLITE	OILDYNE
High Pressure	2250 +/-250 psi	2400 +/-200 psi
Low Pressure	650 +/-150 psi	600 +/-200 psi
Flow Rate @ 1000 psi	45 cu. in. per min.	60cu.in.per min.
High Pressure Control	1600 to 2000 psi	2400 +/-200 psi
Thermal Relief	2250 +/-250 psi	3000 + 300-200 psi
Hydraulic Fluid	MIL-H-5606A	MIL-H-5606
Pressure Switch		
Open (OFF) Pressure	1800 +/-100 psi	
Close (ON) Pressure	300 +/-psi below opening pressure	

6-4. HYDRAULIC PUMP. (PRESTOLITE, OILDYNE)

6-5. REMOVAL OF HYDRAULIC PUMP. The hydraulic pump with reservoir incorporated is located in the aft section of the fuselage. Access to the pump is through the access panel in the aft wall of the baggage compartment.

- a. Disconnect the pump electrical leads from the pump solenoid relays and the ground wire from the battery shelf.
- b. Disconnect the hydraulic lines from the pump. Cap the line ends to prevent contamination.
- c. Remove the pump by removing the pump attaching bolts.

WARNING

When servicing or inspecting vendor equipment installed in Piper aircraft, it is the user's responsibility to refer to the applicable vendor publication.

6-6. DISASSEMBLY OF HYDRAULIC PUMP. (PRESTOLITE) (Refer to Figure 6-3.) After the hydraulic pump has been removed from the airplane, cap or plug all ports and clean the exterior of the pump with a dry type solvent to remove accumulated dust or dirt. To disassemble any one of the three main components of the pump, proceed as follows:

- a. The base (16) of the pump may be removed from the case (15) as follows:
 1. Cut the safety wire and remove the bolts (17) with washers that secure the base to the pump case.
 2. The shuttle valve within the base should be removed for cleaning purposes only. To remove the valve, cut safety wire. Remove plug with spring and valve.

NOTE

The shuttle valve and pump base are matched, lapped parts. Should it be necessary to replace, replace as an assembly only.

- b. Pump Motor: The pump motor may be removed from the pump and disassembled as follows:
 1. Remove thru bolts (4) from head (1) of motor. Using a knife, cut the seal coating between the motor head and case.
 2. Lift the head up from the case approximately .50 of an inch, this will allow inspection of brushes (3) without the brushes unseating from the commutator. (Refer to Paragraph 6-7, b for brush inspection.) The brush heads are secured to the head assembly.
 3. Raise the head assembly (1) off the armature (8) and note the small thrust ball (7) located between the end of the armature (8) and motor head. Do not misplace this bearing.

4. Draw the armature from the motor frame (9). Note the number of thrust washers (11) mounted on the drive end of the armature shaft.
5. Remove the motor frame from the pump reservoir (13).
- c. The valve body and gear case assembly (15) may be separated from the reservoir (13) as follows:
 1. Remove the screws from the flange of the body and separate the two assemblies.
 2. The pump gears and valves should be removed for cleaning purposes only. To remove cap securing gears, remove cap attaching bolts. There are two valve springs that should be positively identified with their valve cavities. Otherwise, it will be necessary to readjust each valve for proper operating pressure.

NOTE

The Oildyne hydraulic pump is a sealed unit and inspection and repair instructions are available from the vendor (manufacturer) only at this time.

6-7. CLEANING, INSPECTION AND REPAIRS OF HYDRAULIC PUMP. (PRESTOLITE)

- a. Discard all old O-rings.
- b. Remove cap or plugs and clean all parts with a dry type cleaning solvent and dry thoroughly.

NOTE

The conditions at repair require cleanliness, carefulness and proper handling of parts. Ensure the foreign materials are prevented from entering the system and that no parts are damaged.

- c. Inspect pump components for scratches, scores, chips, cracks and wear.
- d. Inspect motor for worn brushes (minimum of .218 of an inch brush remains between the braided wire and commutator end), excess commutator wear and excess bearing wear.
- e. Repairs are limited to O-ring and brush replacement as follows:
 1. One brush holder has the winding wire attached. Locate this wire and remove by using a soldering gun.
 2. The head assembly can now be removed and worked on for ease of brush replacement if required.
 3. Remove brush wire and brush from bimetal heat protector.
 4. Solder new brush wires to head assembly and bimetal heat protector and wire from winding to one brush holder.
 5. Install brush springs and brushes into brush holders and secure in place (temporary) with a piece of string looped around the brush and holder and tied in a knot.

NOTE

Ensure that the braided wire is in the holder slot for proper brush movement.

6. Install the head assembly with new brushes to the frame and commutator in accordance with instructions given in Paragraph 6-8, Step a.

6-8. ASSEMBLY OF HYDRAULIC PUMP. (PRESTOLITE) (Refer to Figure 6-3.)

- a. The pump motor may be assembled and installed to the pump reservoir assembly as follows:
 1. Position the motor frame (9) on the reservoir (13). Note the aligning marks on the frame and reservoir.
 2. Place thrust washers (11), of the same amount removed, on the drive end of the armature (8).
 3. Lubricate the entire length of the armature shaft, on the drive end, with a light grease to protect the O-ring seal from damage and insert the end of the shaft in the reservoir.
 4. Saturate the felt oiling pad around the commutator end bearing with SAE 20 oil. Allow excess oil to drain off the assembling motor.

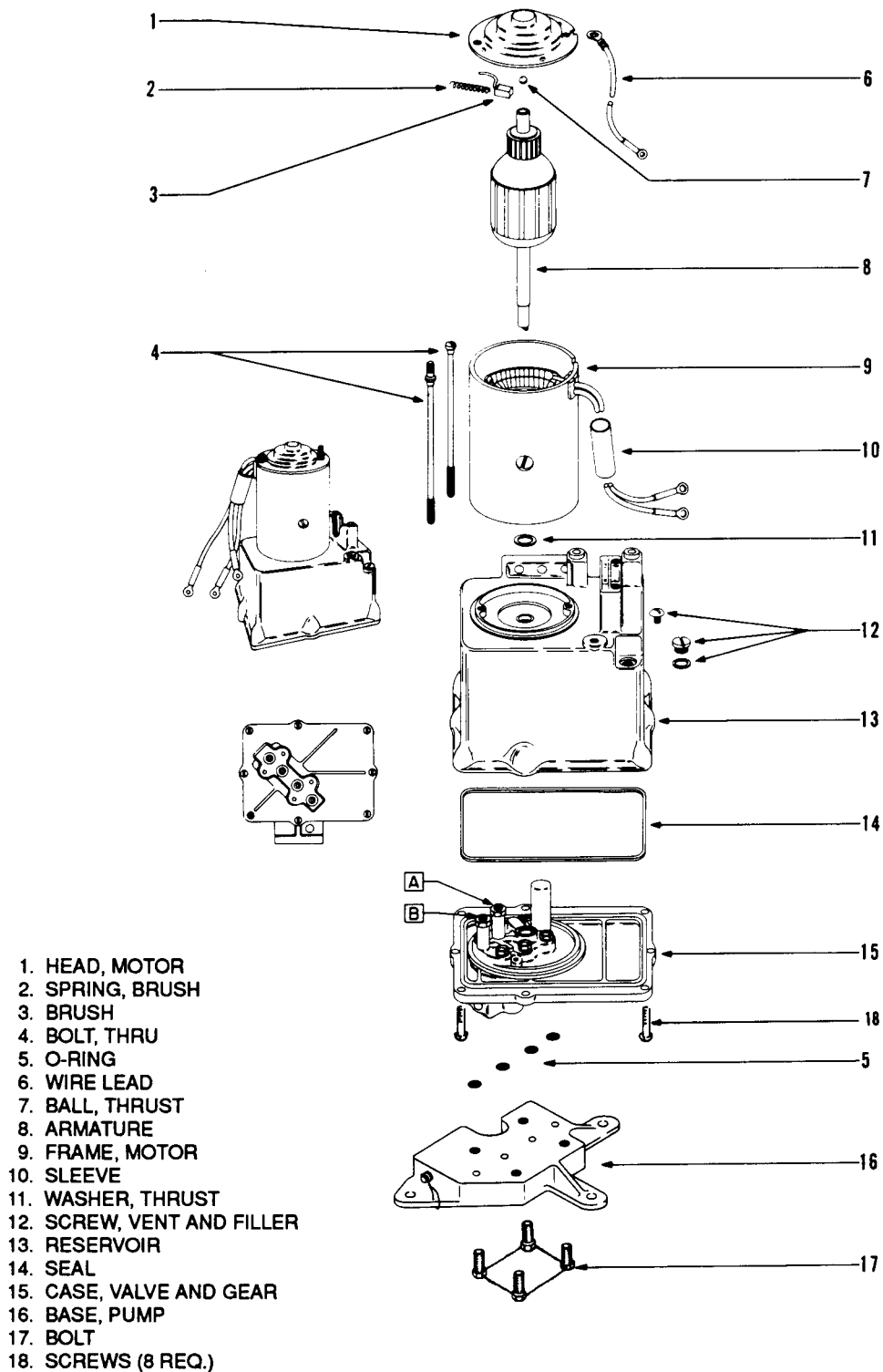
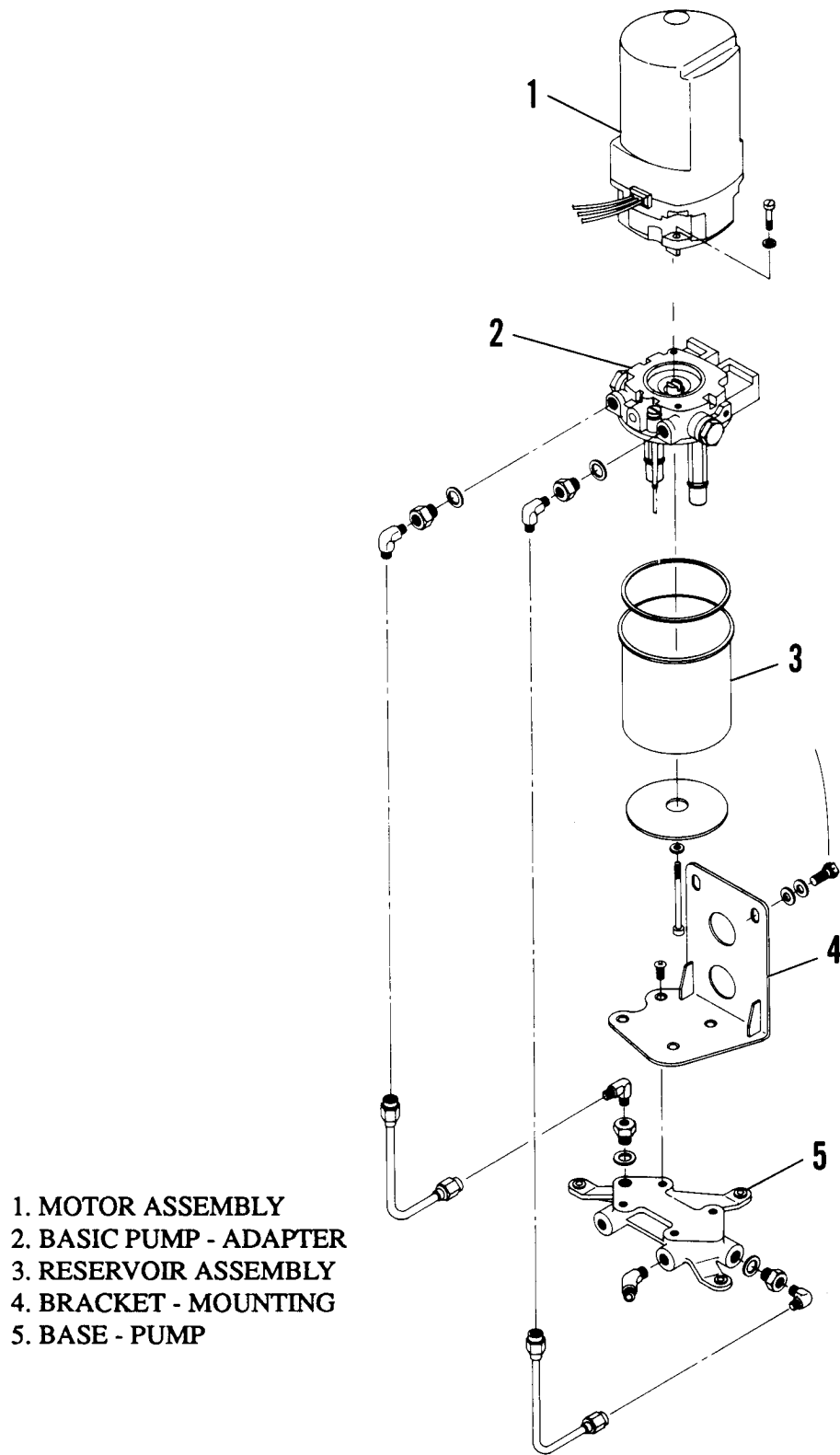

Figure 6-3. Hydraulic Pump/Reservoir, Exploded View (Prestolite)



- 1. MOTOR ASSEMBLY
- 2. BASIC PUMP - ADAPTER
- 3. RESERVOIR ASSEMBLY
- 4. BRACKET - MOUNTING
- 5. BASE - PUMP

Figure 6-3a. Hydraulic Pump/Reservoir, Exploded View (Oilydne)

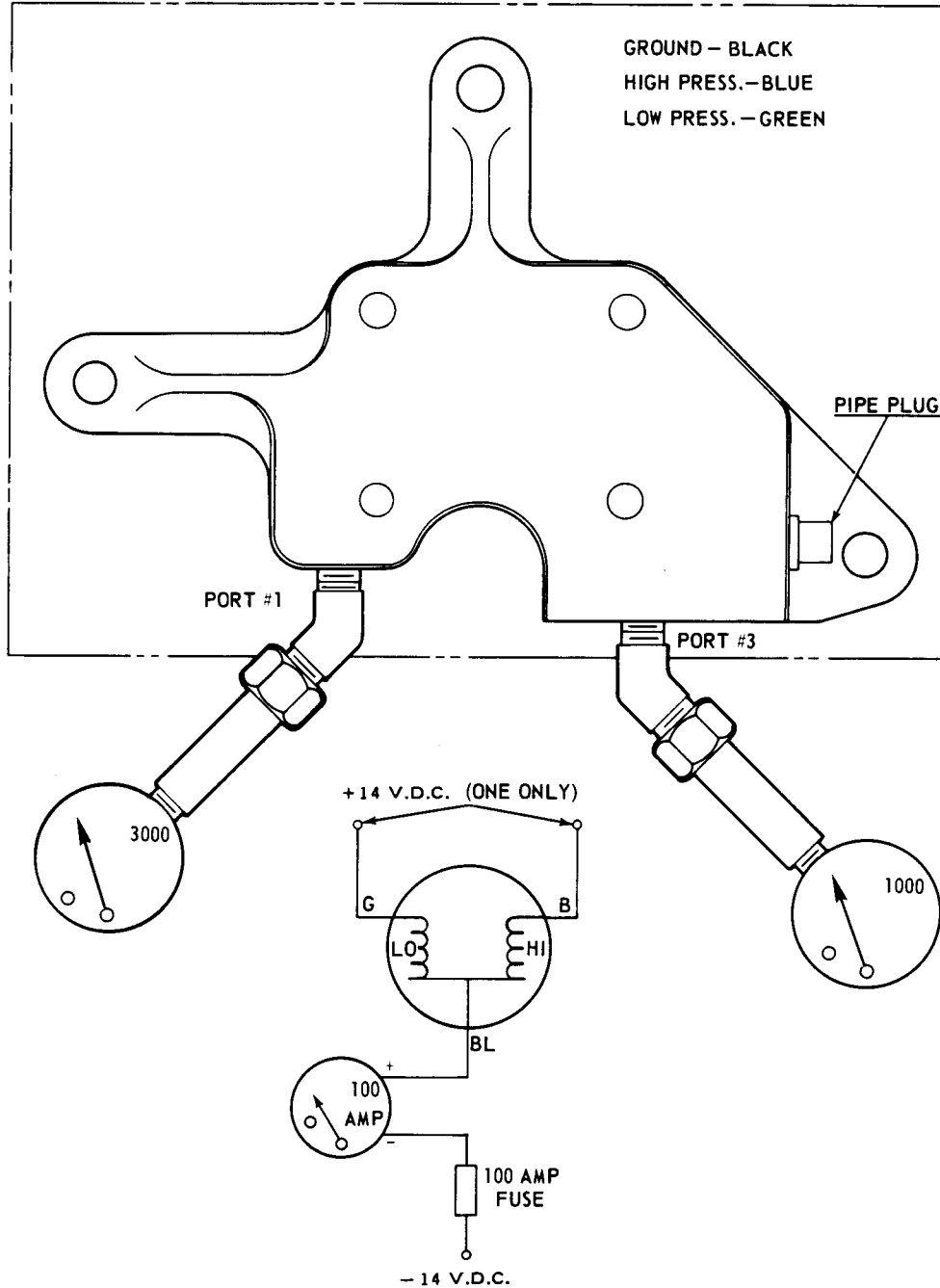

Figure 6-4. Test and Adjustments of Hydraulic Pump (Prestolite)

5. Insert the thrust ball (7) in the bearing of the head assembly (1). To hold the ball in position, place a small amount of light grease inside the bearing.
6. Place head assembly on frame and allow brushes to extend over commutator. Remove the string securing the brushes in the holders. Push head assembly on frame and ensure proper indexing of head and frame assemblies. Secure in place with thru bolts (4).
7. Check freedom of rotation and end play (thrust) of the armature within the assembly. A minimum of .005 of an inch end play is allowable. Should this be incorrect, adjust by adding or removing thrust washers (11) on drive end of armature shaft, as required.
- b. The valve body and gear case assembly (15) may be assembled to the reservoir (13) as follows:
 1. If removed, place the pump gears in the gear case and install cover. Install cover attaching bolts and secure.
 2. Lubricate the reservoir seal ring (14) with hydraulic fluid (MIL-H-5606A) and place it in the recess provided in the case (15).
 3. Position the valve body and gear case assembly (15) with the reservoir (13). Care should be taken when lining up the armature drive with the pump gear. Do not run the motor to do this.
 4. Ascertain that the seal ring is properly positioned and install attaching screws. Tighten the screws so that with the motor connected to a 14-volt source and with an ammeter in the circuit, the current drawn does not exceed 12-amperes.
- c. The base of the pump may be attached to the pump as follows:
 1. With the pump in the up-side down position, lubricate O-ring seals, and install in the recesses provided in the valve body and gear case assembly (15).
 2. Install attaching bolts with washers and torque to 70 inch pounds.
 3. Safety attaching bolts with MS20995-C32 wire.
- d. Conduct motor operational check not to exceed 10 seconds running time.

6-9. TEST AND ADJUSTMENT OF HYDRAULIC PUMP. (PRESTOLITE) (Refer to Figure 6-4.)

- a. Test Equipment:
 1. Hydraulic pump and mounting base.
 2. Pressure gauge (0 to 1000 psi).
 3. Pressure gauge (0 to 3000 psi).
 4. Hoses with fittings to connect between base and gauges.
 5. Power supply (14 Vdc).
 6. Ammeter (0 to 100 amps).
 7. Fuse or circuit protector (100 amp).
- b. Test and Adjustment:
 1. Connect a 0 to 1000 psi gauge to the low pressure port (port No. 3) of the pump base. (The low pressure port, No. 3, is located nearest to the pipe plug installed in the base.)
 2. Connect a 0 to 3000 psi gauge to the high pressure port (port No. 1) of the pump base. (The high pressure port, No. 1, is located farthest from the pipe plug installed in the base.)
 3. Connect the black lead of the pump motor to the negative terminal of the DC power supply.
 4. Fill the pump reservoir and bleed all air from the attached lines. (Lines may be bled by alternately connecting the blue electrical lead and green lead to the positive terminal of the power supply until all air is exhausted.)
 5. Connect the blue lead to the positive terminal of the power supply. Pump should operate and the high pressure gauge should indicate 2250 +/-250 psi. (Should the pressure be incorrect, adjust valve "A", Figure 6-3, in pump reservoir.)
 6. Disconnect the blue lead and the high pressure reading should not drop more than 300 psi in five minutes. High pressure may not be selected until after five minutes.
 7. Connect the green lead to the positive terminal of the power supply. Pump should operate in reverse, dropping the high pressure gauge to zero and the low pressure gauge should indicate between 500 to 800 psi. When the green lead is disconnected, both pressure gauges should indicate zero psi. (Should the pressure of 500 to 800 psi be incorrect, adjust valve "B", Figure 6-3, in pump reservoir.)

*** CHEROKEE ARROW III SERVICE MANUAL**

TABLE VI-II. CHARACTERISTICS, HYDRAULIC PUMP MOTOR

Electrical Characteristics: (Prestolite and Oildyne)	
Voltage Rotation Polarity Operating Current Operating Time Overload Protection Automatic Reset Time Location, Automatic Reset	14 DC Reversible Negative ground 18 amps, max. at 14-volts (both rotations) 5 to 10 seconds with a current load of 100 amps at 77°F. Thermal circuit breaker 12 seconds, max. Commutator end head of motor
Mechanical Characteristics: (Prestolite Only)	
Bearings End Play, Armature	Absorbent bronze (Drive end bearing in upper pump and valve assembly casting.) Steel ball (Thrust, between commutator end head and end of armature shaft.) .005 inch, min. (Adjust by selection of thrust washers on drive end of armature shaft.) <p align="center">NOTE</p> <p align="center"><i>No mechanical characteristics for Oildyne is available at this time.</i></p>

NOTE

During test Steps 5 thru 7, there should not be any external leakage.

8. Should it be necessary to check the pump motor, first connect the ammeter in the electrical circuit with the positive terminal of the meter to the black lead and the negative terminal of the meter to negative terminal of the DC power supply.
9. Connect the blue lead to the positive terminal of the power supply. With the high pressure indication within the 2250 +/-250 psi range on the pressure gauge, the ammeter should read between 35 to 60 amperes. Disconnect the electrical lead.
10. Connect the green lead to the positive terminal of the power supply. With the high pressure indication within the 500 to 800 psi range, the ammeter should read between 15 to 35 amperes.

NOTE

In the event that any of the various tests do not perform satisfactorily, the pump assembly should be overhauled or replaced.

11. Connect the green lead to the power supply to drop pressures before disconnecting the hydraulic lines.

6-10. INSTALLATION OF HYDRAULIC PUMP.

- a. Install the rubber shock mounts through the mounting holes of the pump. Insert a bushing through the holes of each shock mount.
- b. Position the pump on its mounting flange. Install mounting bolt with washer and tighten. (Refer to Figure 6-3.)
- c. Connect the hydraulic lines to the pump.
- d. Connect the pump electrical leads. Green wire to outboard relay, blue wire to inboard relay and black wire to ground on battery shelf.
- e. Check fluid level in pump. Fill per instructions given in Section II.
- f. With the airplane on jacks, operate the pump to purge the hydraulic system of air, and check for leaks. After operation, recheck fluid level.

6-11. GEAR BACK-UP EXTENDER ACTUATOR ASSEMBLY.

WARNING

Piper considers service bulletins of extreme importance and compliance is mandatory.

NOTE

The following paragraphs, 6-11 through 6-14a, on grid pages 1H16 through 1H21, are instructions directed towards owners who have opted to comply with Piper Service Bulletin 866A Part II, and keep the back-up gear extender system operational.

6-12. REMOVAL OF GEAR BACK-UP EXTENDER ACTUATOR ASSEMBLY. (Refer to Figure 6-6.) The back-up extender actuator is located under the rear seat. To reach the actuator, remove the rear seats.

- a. Disconnect the actuator electrical leads at the quick disconnect terminals.
- b. Disconnect the pressure (13) and static (11) hoses from the elbows (12) of the diaphragm housing (10) by releasing clamps and sliding the hoses from their elbows. The hoses should be tagged for ease of reassembly.
- c. Place a shop cloth under the actuator hydraulic valve (25) to absorb fluid and then disconnect the hydraulic lines (5) and (26) from the elbows (4) and (27) of the hydraulic valve (25). Cover the lines to prevent contamination.
- d. Remove the machine screws that secure the actuator base to the mounting brackets. There are two mounting screws at the inboard side of the base and one at the outboard side of the diaphragm housing. Remove the actuator from the mounting brackets.

THIS PAGE INTENTIONALLY LEFT BLANK

1. ALIGNING TOOL
2. LANDING GEAR OVERRIDE SUPPORT BRACKET
3. DIAPHRAGM SUPPORT BRACKET

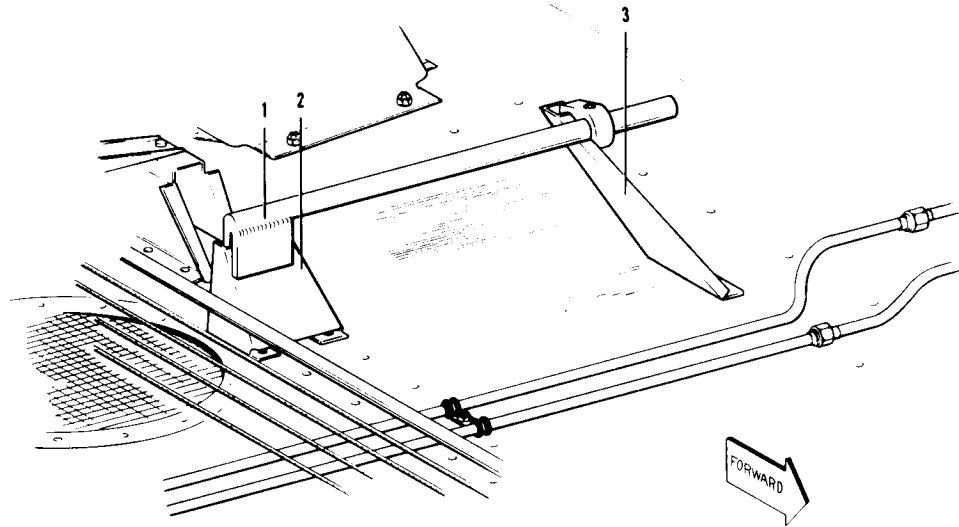

Figure 6-5. Checking Aligning Brackets of Gear Back-Up Extender Actuator

6-13. INSTALLATION OF GEAR BACK-UP EXPENDER ACTUATOR ASSEMBLY. (Refer to Figure 6-6.)

- a. Position the gear back-up extender actuator against its mounting brackets and install attaching machine screws. Do not tighten screws.

NOTE

With the base attached and before installing the attaching screw through the ring of the diaphragm housing, ensure that the attaching holes in the housing and mounting bracket align without using force. Should they misalign, it may be necessary to reform the main fuselage mounting bracket.

To reform the main fuselage mounting bracket, an Aligning Tool may be used. (Refer to Figure 6-5.) This tool may be fabricated from dimensions given in Figure 6-10. When proper alignment has been accomplished, tighten the machine screws.

- b. Move the actuator on its mounting brackets to allow the manual control push rod to have maximum clearance from the left stabilator cable and center in the fairlead on the aft face of the main spar box. Check system for sufficient travel and freedom of movement of controls. Tighten actuator attaching screws.

* CHEROKEE ARROW III SERVICE MANUAL

NOTE
For aircraft that have opted to comply with Piper Service Bulletin 866A Part II only.

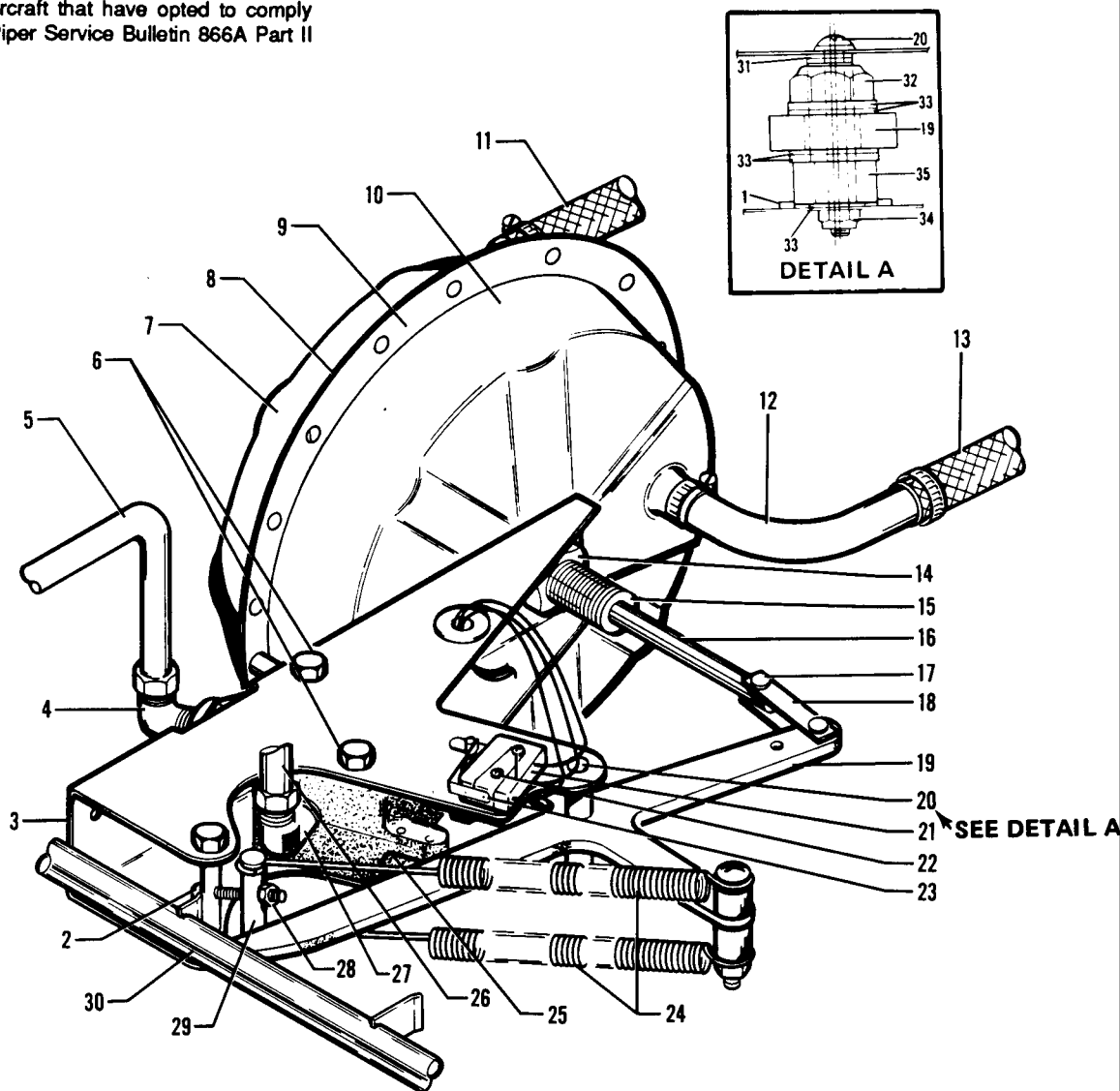

- 1. CAM LOCK
- 2. SCREW, ADJUSTING
- 3. BASE
- 4. ELBOW
- 5. TUBE
- 6. BOLT & NUT
- 7. HOUSING ASSEMBLY, STATIC
- 8. SEAL
- 9. RING, HOUSING
- 10. HOUSING ASSEMBLY, PRESSURE
- 11. HOSE, STATIC
- 12. ELBOW

- 13. HOSE, PRESSURE
- 14. NUT
- 15. BUSHING, TEFLON
- 16. SHAFT, DIAPHRAGM
- 17. CLEVIS PIN
- 18. LINK
- 19. ARM ACTUATING
- 20. SCREW
- 21. SWITCH, PUMP
- 22. SCREW & NUT
- 23. ACTUATOR, SWITCH
- 24. VALVE, HYDRAULIC

- 25. VALVE, HYDRAULIC
- 26. TUBE
- 27. ELBOW, RESTRICTOR
- 28. ELBOW
- 29. ANCHOR
- 30. PUSH ROD
- 31. SPACER
- 32. ADJUSTMENT NUT
- 33. WASHERS
- 34. NUT
- 35. ECCENTRIC BOLT

Figure 6-6. Gear Back-up Extender Actuator

NOTE

Care should be used when attaching the forward hose (13) to the diaphragm assembly (10) so that no strain is placed on the teflon bushing (15) and diaphragm shaft (16), thus causing friction in movement.

- c. Connect the hydraulic lines (5) and (26) to the elbows (4) and (27) of the actuator hydraulic valve (25).

NOTE

A special fitting (27) with a restriction orifice of .063 of an inch is installed in the side of the hydraulic valve (25). Do not mistake this for a standard AN fitting.

- d. Connect the pressure (13) and static (11) hoses to the elbows (12) of the diaphragm housing (10). Secure hoses with clamps.
- e. Connect the actuator electrical leads terminal to their mating terminals and insulate. Refer to the electrical schematic for hookup.
- f. Check the actuator adjustments as given in Paragraph 6-14.
- g. Install the rear seat.

6-14. CHECK FOR ADJUSTMENT OF GEAR BACK-UP EXTENDER ACTUATOR. (Refer to Figure 6-6.)

- a. If diaphragm failure is suspected, note the following:
 1. If the landing gear retracts or extends at too high an airspeed or will not retract at all unless the back-up extender is placed in the override position, then the diaphragm is possible defective.
 2. If it is determined that the diaphragm is defective, then remove the Back-Up Extender per instructions given in paragraph 6-12 and install Piper Kit No. 761 138V, Back-Up Gear Extender Diaphragm Replacement. Instructions for installing the diaphragm are included in the kit.
 3. Following completion of Replacement Kit, reinstall the extender unit in the aircraft and functionally test and adjust as outlined below and in paragraph 6-14a.
- b. Adjustment of the gear back-up extender actuator is preset to allow the hydraulic valve (25) of the actuator to open when the airspeed is reduced below 103 KIAS for PA-28R-201T or 95 KIAS for PA-28R-201 with the engine power OFF. This adjustment is accomplished by setting the tension of spring (24) on the actuator with adjustment screw (2) as follows:

NOTE

The airspeed at which the hydraulic valve of the actuator opens was preset at the factory under ideal conditions. There should be some variations at different altitudes and atmosphere conditions.

CAUTION

The micro switch (21) and eccentric bolt (35) must not be adjusted. These components are set at the factory under specific conditions, with the use of special set-up equipment.

NOTE

This adjustment will require two persons, a qualified pilot and a mechanic to set the actuator adjustment screw (2).

1. Remove the bottom of the rear seat.
2. The pivot screw (20) should be torqued 8 to 10 inch-pounds.
3. Loosen the jam nut (28) of the adjustment screw (2).
4. Ascertain that the electrical switch (21) will actuate with the use of the emergency gear extension lever.
5. Fly the airplane (refer to Owner's Handbook). Should the spring tension be out of adjustment very much, it may be necessary to assist gear retraction with the use of the emergency gear extension lever moved to the up override position.
6. Loosen the adjustment screw (2) by turning counterclockwise until spring (24) tension is free.

WARNING

While making adjustments, do not lay tools in area exposed by the removal of floorboard. This may interfere with airplane controls.

7. With the airplane at a safe altitude, slow the airplane to a glide of 120 KIAS for PA-28R-201T or 110 KIAS for PA-28R-201 with the gear selector handle up and the throttle reduced to power OFF. (Gear unsafe light and horn will indicate when power is reduced.) At 120 KIAS for 28R-201T or 110 KIAS for 28R-201, slow the airplane at a rate of one (1) knot per second until 103 KIAS for PA-28R-201T or 95 KIAS for PA28R-201 is obtained, hold the airplane at this speed.

NOTE

Adjustment of the nut (32) may be necessary to increase or decrease the spread between the gear up and gear down actuation speeds. To expand the spread between these speeds, loosen the nut. Tighten the nut to bring the airspeeds closer together. Whenever the nut is adjusted, it may be necessary to readjust the tension on the springs (24) and to repeat the nut adjustment procedure. If the eccentric bolt (35) is installed on the unit being adjusted, CAUTION should be observed so as not to disturb its position in relation to the rest of the unit.

8. With the glide established, turn the adjustment screw (2) clockwise until the gear drops. (First indication of gear dropping will be that the gear unsafe light comes ON.)
9. Climb again to a safe altitude and check that the gear drops at the correct airspeed.
10. Land the airplane and tighten the adjustment screw jam nut (28).

- c. To check adjustment of electrical switch, the following procedure may be used:
 1. Place the airplane on jacks. (Refer to Jacking, Section II.)
 2. Move the mixture control back to idle cut-off and the throttle to full forward to prevent gear warning horn from sounding during adjustment.
 3. Ascertain that the actuator tension springs are properly adjusted according to Step b.
 4. Retract the landing gear hydro-electrically by turning the master switch ON, raising the emergency gear extension lever and moving the gear selector handle to the up position. The emergency gear extension lever must be retained in the up position to keep the gear up.
 5. Check for proper switch operation by the following procedure:
 - (a) Turn master switch ON and move gear selector handle to the up position. Pump should not operate.
 - (b) Move the emergency gear extension lever to the up override position. Pump should operate and gear should retract.
 - (c) With selector lever up, slowly lower emergency gear extension lever to allow gear to drop to down position. The pump should not operate at any time during extension.
 - (d) Turn master switch OFF.
 6. Check gear operation in the normal manner with the use of the gear selector handle. The emergency extension lever must be held in the up override position.
 7. Ascertain that gear is down and locked and remove airplane from jacks. Then flight check the retractable landing gear system. (Refer to Paragraph 6-14a.)

6-14a. OPERATION CHECK OF RETRACTABLE LANDING GEAR SYSTEM.

- a. Maximum Gear Extend: Place the gear selector in the down position at 129 KIAS. In approximately 5 to 10 seconds the three green gear lights should be on indicating that the gear is down and locked.
- b. Minimum Gear Retract: Allow approximately 8 seconds for the pressure in the hydraulic system to normalize between gear extension and retraction. Place the selector switch in the UP position at 107 KIAS. In approximately 5 to 10 seconds all the gear indicating lights should be out indicating that the gear is fully retracted.
- c. Override Gear Down and Up:
 1. Down: Establish a normal glide at approximately 120 KIAS for PA-28R-201T or 110 KIAS for PA-28R-201 with power at idle. Slowly move the override lever down, while observing the ammeter to confirm that the hydraulic pump does not start. The gear should go down and lock. Move the gear selector switch down. Release the override lever. The gear should remain down.
 2. Up: Set maximum climb power. Maintain approximately 70 KIAS for PA-28R-201T or 65 KIAS for PA-28R-201 for approximately 15 seconds. Move the gear selector switch to the up position. The gear should not retract. Pull the override lever up. The gear should retract. Allow the airspeed to increase to at least 115 KIAS for PA-28R-201T or 110 KIAS for PA-28R-201. Release the override lever and the gear should remain up.
- d. Gear "Back-Up" Down and Up:
 1. Gear Down: Set power at idle. Glide the aircraft at 120 KIAS for PA-28R-201T or 110 KIAS for PA-28R-201. Decrease the airspeed at the rate of 1 knot per second. The gear should start down between 101 and 109 KIAS for PA-28R-201T or 93 and 101 KIAS for PA-28R-201. Place the gear selector switch down after the gear is down and locked.
 2. Gear Up: Set maximum climb power. Maintain approximately 70 KIAS for PA-28R-201T or 65 KIAS for PA-28R-201 for approximately 15 seconds. Move the gear selector up. The gear should stay down and locked. Increase the airspeed at the rate of 1 knot per second. The gear should begin to retract between 76 and 84 KIAS for PA-28R-201T or 73 and 81 KIAS for PA-28R-201 at zero density altitude. The speed at which the gear starts up will increase 1 knot for PA-28R-201T or 1.3 knots for PA-28R-201 for each 1000 increase of density altitude.

3. Manual Override Up Latch: With the gear up, the aircraft in normal flight configuration, select up on the gear override lever. Engage the up latch. The amber up latch warning light, below the gear selector switch, should be flashing. Gradually slow the aircraft below the auto gear extend speed and observe that the gear stays fully retracted. Disengage the up latch. The flashing amber warning light should go out.
- e. Gear Indicator Lights:
 1. The green lights indicate when the corresponding gear is in the down and locked position. Turn landing light switch on and off- observe ammeter for indication.
 2. The red gear warning light will indicate an unsafe condition. It will indicate when the gear is in an intermediate position neither fully up nor down. In conjunction with the gear warning horn, it will indicate when the throttle setting is less than 14 +/- 2 inches of manifold pressure or when flaps are set beyond 10° for aircraft that complied with Piper Service Bulletin 866A Part I, and have the back-up extender disabled, or s/n 2837001 and s/n 2803001 and up while the gear is not down and locked. It will also indicate when the gear is down and locked while the selector switch is in the UP position.
- f. The Gear Warning Horn: The gear warning horn will sound whenever the red gear warning light is on and the throttle is closed or below 14 +/- 2 in. Hg of manifold pressure.
- g. Micro Switch Check:
 1. The aft throttle micro switch setting is checked as follows: with the gear up, reduce the throttle at a normal rate. The gear warning horn and the red light should come on at 14 inches of manifold pressure +/-2.

NOTE

PA-28R-201 s/n's 2837001 and up, and PA-28R-201T s/n's 2803001 and up do not have landing gear back-up extender systems installed.

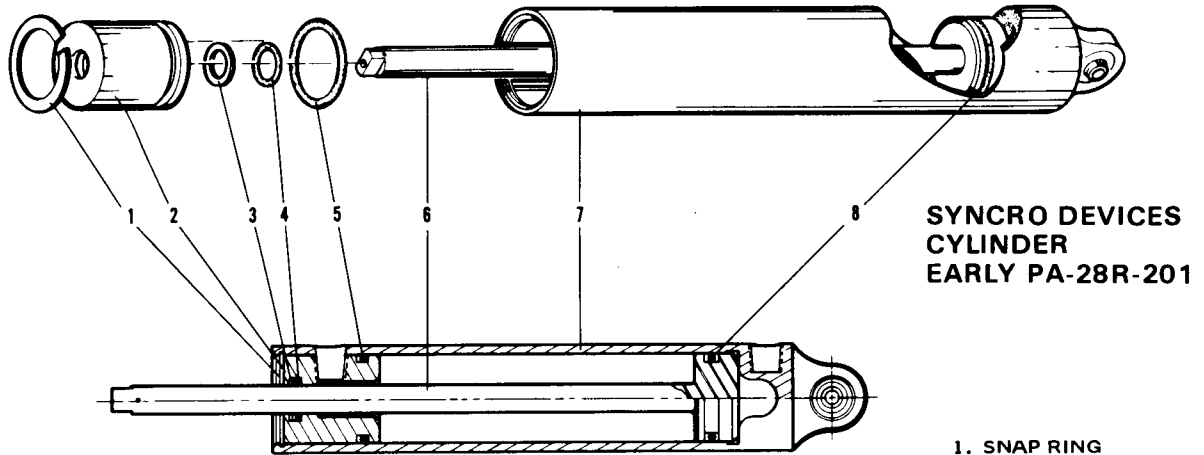

**SYNCRO DEVICES
CYLINDER
EARLY PA-28R-201**

1. SNAP RING
2. END GLAND
3. BACK-UP RING
4. "O" RING
5. "O" RING
6. PISTON
7. BODY, CYLINDER
8. "O" RING
9. SAFETY WIRE

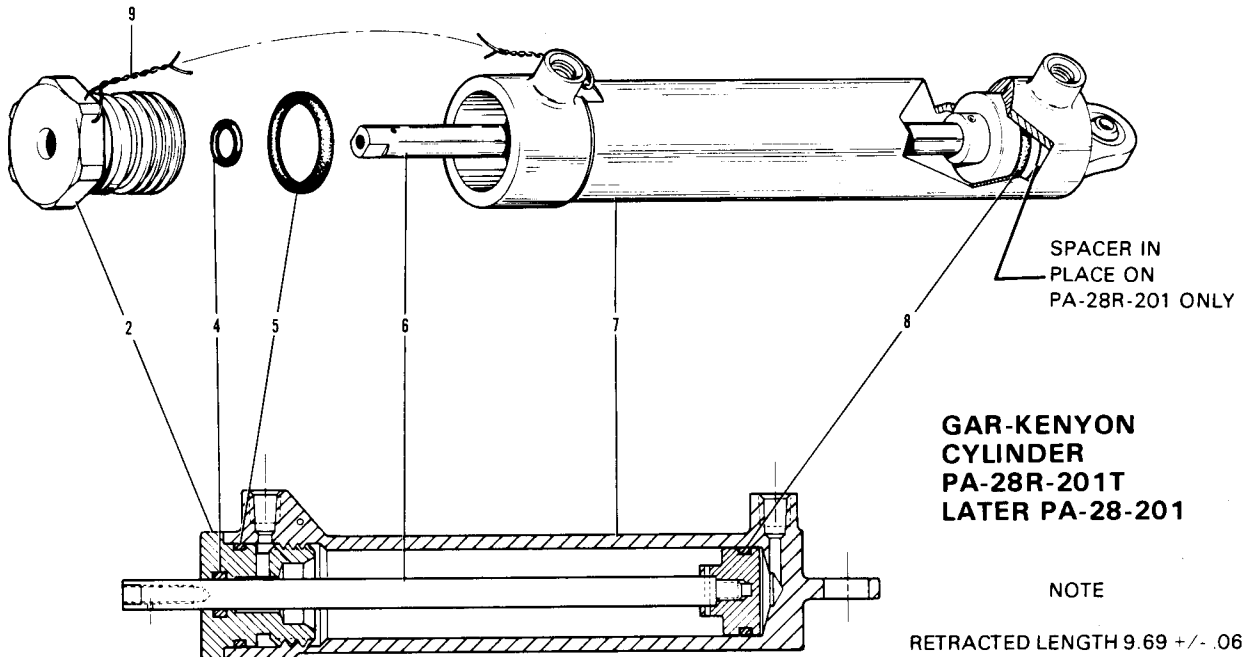

**GAR-KENYON
CYLINDER
PA-28R-201T
LATER PA-28-201**

NOTE

RETRACTED LENGTH 9.69 +/- .06
IN. ON PA-28R-201 ONLY.
RETRACTED LENGTH 8.55 +/- .06
IN. ON PA-28R-201T ONLY.

Figure 6-7. Nose Gear Actuating Cylinder

6-15. NOSE GEAR ACTUATING CYLINDER.

6-16. REMOVAL OF NOSE GEAR ACTUATING CYLINDER.

- a. Place the airplane on jacks. (Refer to Jacking, Section II.)
- b. Disconnect the hydraulic lines from the actuating cylinder and cover the open line ends to prevent contamination.
- c. Disconnect the cylinder operating rod end from the downlock hook by removing attachment nut and bolt.
- d. Disconnect the cylinder from its attachment fitting by removing nut and bolt.
- e. Remove the cylinder from the wheel well.

6-17. DISASSEMBLY OF NOSE GEAR ACTUATING CYLINDER. (Refer to Figure 6-7.)

- a. With the cylinder removed from the airplane, remove the fitting from the piston rod (6) end of the cylinder (7). Mark the position of the fitting to facilitate reinstallation.
- b. On Syncro Devices nose gear actuating cylinders, remove the snap ring (1) from the annular slot in the end of the housing. On Gar-Kenyon nose gear actuating cylinder, remove safety wire (9) and unscrew end gland (2).
- c. On Syncro Devices assemblies, pull the piston (6) with end gland (2) from the cylinder housing. On Gar-Kenyon assemblies, remove piston (6) after unscrewing end gland (2).

6-18. CLEANING, INSPECTION, AND REPAIR OF NOSE GEAR ACTUATING CYLINDER.

- a. Clean the cylinder parts with a suitable dry type solvent and dry thoroughly.
- b. Inspect the cylinder assembly for the following:
 1. Interior walls of the cylinder and exterior surfaces of the piston for scratches, burrs, corrosion, etc.
 2. Threaded areas for damage.
 3. Rod end fitting and swivel fitting of cylinder for wear, cracks and corrosion.
 4. O-rings for damage.
- c. Repairs to the cylinder and limited to polishing out small scratches, burrs, etc. and replacing parts.

6-19. ASSEMBLY OF NOSE GEAR ACTUATING CYLINDER. (Refer to Figure 6-7.)

- a. Install O-ring (5) on the exterior of the end gland (2).
- b. Install O-ring (4) line the interior of the end gland. The Syncro Devices assemblies also include a ring back-up (3) with the O-ring (4).
- c. Install O-ring (8) on the body of the piston assembly.
- d. Install the spacer into the cylinder body if applicable.
- e. Lubricate the areas around the O-rings with hydraulic fluid, slide the end gland on the piston rod and the piston into the cylinder housing (7).
- f. Secure the end gland in the cylinder by installing the snap ring (1) in the annular slot in the Syncro Devices cylinder. The end gland on the Gar-Kenyon cylinder is secured by threading gland into cylinder body (7) and securing with safety wire (9).
- g. Install restrictor fitting in the piston rod end of the cylinder.
- h. Check smoothness of operation of the piston.

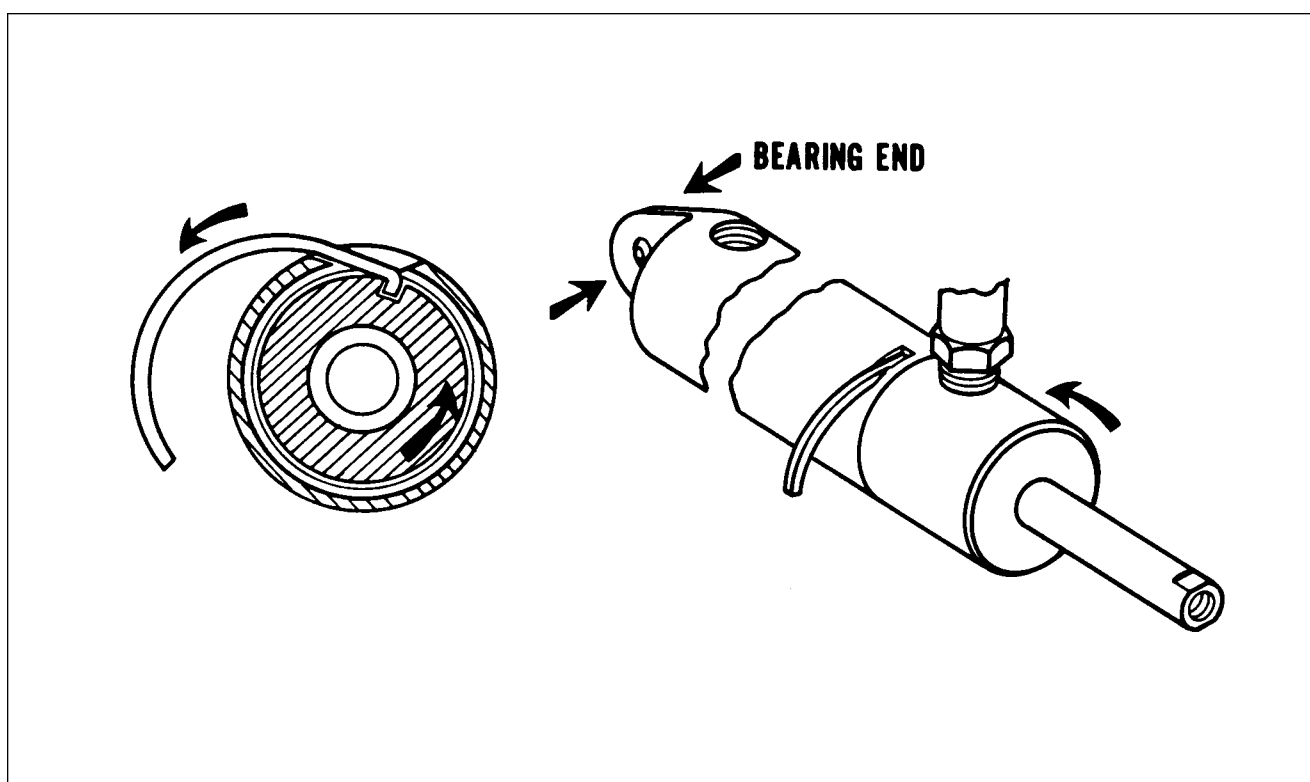

Figure 6-8. End Gland Locking Device

6-20. INSTALLATION OF NOSE GEAR ACTUATING CYLINDER.

- a. Attach the cylinder to its attachment fitting using bolt and nut.
- b. Attach the operating rod end to the downlock hook using bolt. Install nut after adjustment is completed.
- c. Connect the hydraulic lines to the cylinder fittings.
- d. Check the adjustment of the cylinder rod end. (Refer to Adjustment of Nose Landing Gear, Section VII.)
- e. Operate pump to purge system of air and check fluid level in reservoir.
- f. Remove the airplane from jacks.

6-21. MAIN GEAR ACTUATING CYLINDER.

6-22. REMOVAL OF MAIN GEAR ACTUATING CYLINDER.

- a. Place the airplane on jacks. (Refer to Jacking, Section II.)
- b. Disconnect the hydraulic lines from the actuating cylinder and cover the open line ends to prevent contamination.
- c. Disconnect the gear downlock spring from the swivel fitting at the upper end of the spring.
- d. Remove the downlock spring swivel fitting and disconnect the cylinder operating rod end from the upper side brace retraction fitting by removing the attaching nut, washer and bolt.
- e. Disconnect the cylinder from its attachment by removing nut and bolt.
- f. Remove the cylinder from the wheel well.

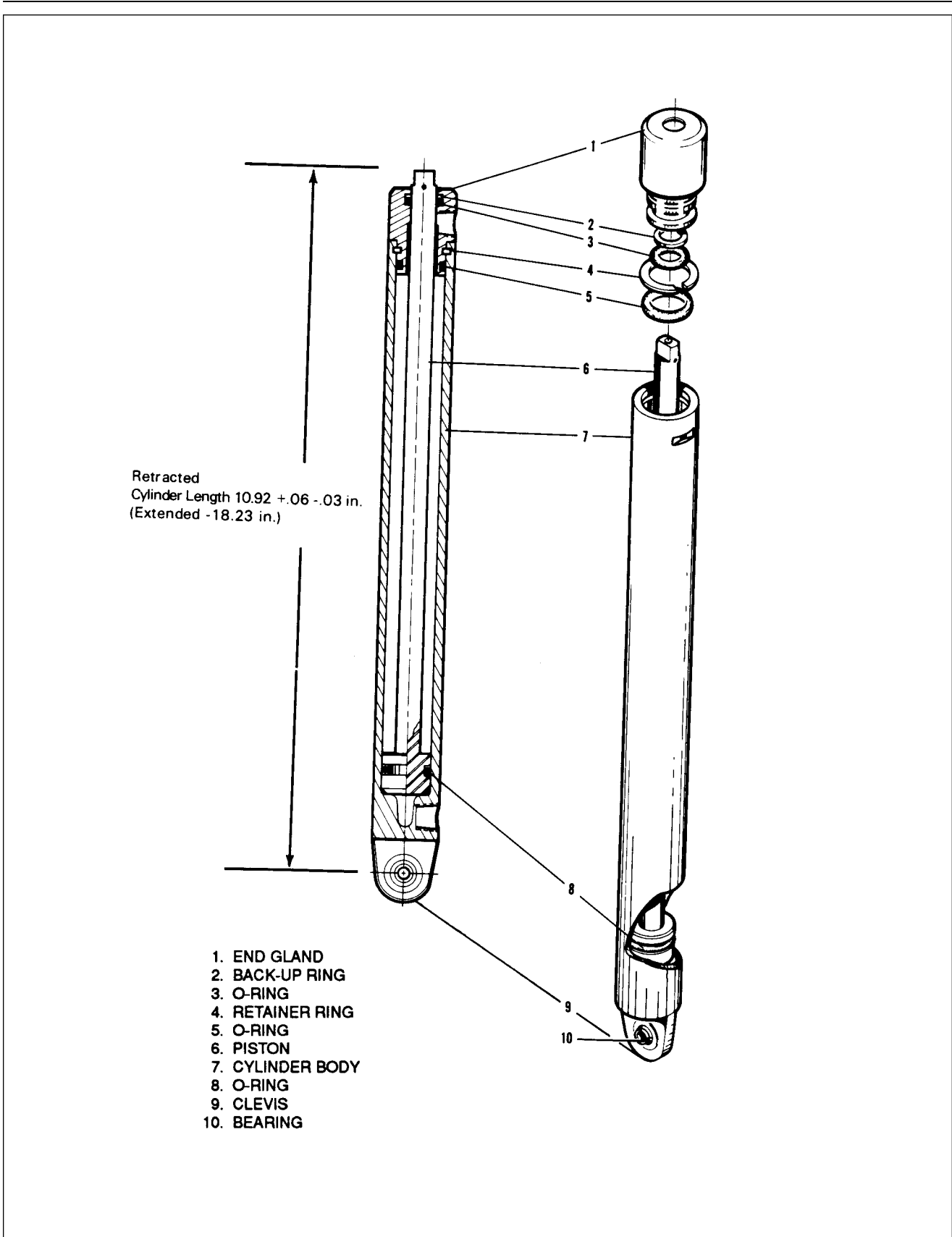

Figure 6-9. Main Gear Actuating Cylinder

6-23. DISASSEMBLY OF MAIN GEAR ACTUATING CYLINDER. (Refer to Figure 6-9.)

- a. With the cylinder removed from the airplane, push the piston rod (6) (by hand) toward the clevis (9) to remove oil from the unit.
- b. Put clevis (9) only in a soft jaw vise and clamp against the clevis bearing (10).
- c. If no pipe fitting is installed in the port of the end gland (1), install a fitting (1/8-27) into the port. This fitting need not be tight as it will be used for leverage only.
- d. Rotate the gland (with use of fitting) until the end of the gland lock ring (4) shows in the slot in the cylinder body (7). Reverse rotation of the gland to allow the lock ring to move out of the slot. (Refer to Figure 6-8.) (It may be necessary to give the ring an assist to start out of the slot. If so, insert a strong wire pick or other available tool in the slot to lift up the end of the ring and then rotate gland.)
- e. Pull the piston (6) and end gland from the cylinder.
- f. Remove O-ring as desired.

6-24. CLEANING, INSPECTION AND REPAIR OF MAIN GEAR ACTUATING CYLINDER.

- a. Clean the cylinder parts with a suitable dry type solvent and dry thoroughly.
- b. Inspect the cylinder assembly for the following:
 1. Interior walls of cylinder and exterior surfaces of piston for scratches, burrs, corrosion, etc.
 2. Threaded areas for damage.
 3. End fitting retainer slot for excess wear.
 4. Rod end fitting and swivel fitting of cylinder for wear and collision.
- c. Repairs to the cylinder are limited to polishing out small scratches, burrs, etc, and replacing parts.

6-25. ASSEMBLY OF MAIN GEAR ACTUATING CYLINDER. (Refer to Figure 6-9.)

- a. Install O-ring (5) on the exterior of the end gland (1).
- b. Install O-ring (3) and back-up ring (2) in the interior of the end gland.
- c. Install O-ring (8) on the body of the piston assembly.
- d. Lubricate the areas around the O-rings with hydraulic fluid, park-o-lube or vaseline, slide the end gland on the piston rod and the piston into the cylinder housing (7).
- e. Insert the hook end of a new long ring (4) (P/N 755 997) in the slot in the cylinder body (7) and slot in the end gland (1). Rotate gland counterclockwise to completely wrap lock ring into assembly.
- f. Align port in end gland and cylinder body.
- g. Check smoothness of operation of piston and static pressure test unit to check for possible cut O-rings.

6-26. INSTALLATION OF MAIN GEAR ACTUATING CYLINDER.

- a. Attach the cylinder to its attachment fitting in the wheel well using bolt and nut.
- b. Attach the operating rod end and downlock spring swivel fitting to the upper side brace retraction fitting by using bolt, washer and nut. Ascertain swivel fitting is free to rotate.
- c. Connect the downlock spring to the swivel fitting.
- d. Check the adjustment of the cylinder rod end. (Refer to Adjustment of Main Landing Gear, Section VII.)
- e. Operate pump to purge system of air and check fluid level in reservoir.
- f. Remove airplane from jacks.

6-27. HYDRAULIC LINES.

6-28. REMOVAL AND INSTALLATION OF HYDRAULIC LINES. Remove a damaged hydraulic line by disconnecting the fitting at each end and by disconnecting where secured by brackets. Refer to Figure 6-2 as an aid in the location of attaching brackets and bends in the lines. Provide a small container for draining the line. Install a new or repaired line in reverse. Operate the pump to purge the system of air and check fluid level in reservoir.

6-29. TESTING HYDRAULIC SYSTEM. The hydraulic system should be tested to determine that it functions properly when suspicion of a problem exists, or after performing any service or repairs, it is suggested that the airplane be connected to an outside source of power in order to conserve the battery. (Refer to External Power Receptacle, Section II.)

CAUTION

Turn the master switch OFF before inserting or removing external power supply plug.

NOTE

The following instructions will be directed towards testing that involves systems incorporating the Prestolite and Oildyne hydraulic pumps. During all tests, add hydraulic fluid MIL-H-5606 to reservoir as necessary to keep fluid level visible to a level 1/2 inch below top of the filler hole on the Prestolite pump, and to the FULL indication on the dipstick, with the dipstick turned all the way in.

CAUTION

After filling the Oildyne reservoir, tighten dipstick, then back off 1 1/2 turns. This is essential to allow the reservoir to be vented.

- a. Place airplane on jacks. (Refer to Jacking, Section II.)
- b. With gear down, master switch ON, and circuit breaker IN, or closed, check to see that there are three green lights, the red warning light is OFF and that the gear warning horn is not sounding.
- c. Now place the landing gear in the UP position. Note that the pump operates immediately and the red gear unsafe light illuminates on the instrument panel until the gear is fully retracted. The hydraulic pump should stop operating after full gear retraction.
- d. Place the gear in the DOWN position. The gear should extend and lock in position and the three green gear position lights will illuminate when all three gears are locked in the down position.
- e. For airplanes that have complied with Piper Service Bulletin 866A, Part II and have the gear back-up extender system operational, refer to Paragraph 6-14 for Check and Adjustment Procedures.
- f. Airplanes with the electric flap system incorporated, ensure that the flaps are rigged properly.
- g. Put the gear selector in the up position. Check again that the gear retracts normally, that the pump stops, and the red warning light goes out.
- h. Put the flap selector in the first down (10 degree) position, and ensure that the flaps operate normally to first position, and that the horn does not sound.
- i. Put the flap selector in the second down (25 degree) position, and ensure that the flaps operate normally to second position, and that the horn does not sound.
- j. Put the flap selector in the full down position, and observe that the flaps operate normally to the full down position, and that the horn continues to sound.
- k. Return the flap selector to the first down (10 degree) position and check that they operate to first position and that the warning horn stops sounding.
- l. Now return the flaps to the full up (0 degree) position and check that the flaps have fully retracted and the warning horn does not sound.

- m. Put the gear selector switch in the down position, and ensure that the gear has extended, the pump has stopped running, and the three green safe lights are illuminated.
- n. Return the flap selector to the fill down position, and note that the flaps operate to the full down position, and the warning horn does not sound.
- o. Now return the flap selector to the full up position, and observe that the flaps operate to the full up position, and the warning horn does not sound.
- p. Turn the Master Switch OFF.

CAUTION

Prior to removing the airplane from jacks, turn the master switch on and determine that ALL THREE green lights are illuminated. This will ensure that the landing gear is down and locked.

6-30. SERVICING HYDRAULIC PUMP/RESERVOIR. The fluid level of the reservoir of the combination pump and reservoir should be checked every 50 hours by viewing the fluid through the filler plug hole in the Prestolite and by checking the dipstick indication on the Oildyne. Access to the pump is through the access panel in the aft wall of the baggage compartment.

Should the fluid level be low, add fluid, MIL-H-5605A, and return the filler plug on the Prestolite pump and dipstick on the Oildyne. After tightening the dipstick on the Oildyne, loosen it 1 In turns to allow the reservoir to vent.

CAUTION

The Prestolite pump has a small hole located under the vent screw head. Retain 1/64 inch clearance between the screw head and the small vent hole. The Oildyne pump must have the dipstick loosened 1 1/2 turns to properly vent it.

CHEROKEE ARROW III SERVICE MANUAL

TABLE VI-III. HYDRAULIC SYSTEM TROUBLESHOOTING

Trouble	Cause	Remedy
Landing gear retraction system fails to operate.	§ Landing gear actuator circuit breaker open.	§ Reset circuit breaker and determine cause for open circuit breaker.
	§ Landing gear selector circuit breaker open.	§ Reset circuit breaker and determine cause for open circuit breaker.
	§ Landing gear actuator circuit wires broken.	§ Check wiring.
	§ Landing gear selector circuit wires broken.	§ Check wiring.
	§ Safety(squat)switch out of adjustment.	§ Readjust switch. (Refer to Adjustment of Safety Switch, Section VII.)
	§ Squat switch inoperative.	§ Replace switch.
	§ Pressure switch inoperative.	§ Replace switch.
	§ Pump retraction solenoid inoperative (inboard solenoid).	§ Replace solenoid.

§ Applies to all airplanes.

NOTE

If the retracting solenoid of the pump can be heard to actuate when operating the gear selector switch, it may be assumed that the gear control circuit is operating properly and the actuator circuit should be further checked.

CHEROKEE ARROW III SERVICE MANUAL

TABLE VI-III. HYDRAULIC SYSTEM TROUBLESHOOTING (cont)

Trouble	Cause	Remedy
Landing gear retraction system fails to operate (cont)	§ Gear selector switch ground incomplete. § Gear selector switch inoperative. § Hydraulic pump ground incomplete. § Hydraulic pump inoperative. * Auxiliary extender switch inoperative. § Hydraulic fluid in reservoir below operating level. § Battery low or dead. § Pressure head air passage obstructed. § Pressure head hose off. * Split or hole in diaphragm of auxiliary extender. Can be checked by using override.	§ Check ground. § Replace switch. § Check ground. § Replace or overhaul pump. * Replace unit. § Fill reservoir with hydraulic fluid. § Check condition of battery. § Reconnect hose. * Replace unit.
Landing gear extension system fails to operate.	Landing gear actuator circuit breaker open.	Reset circuit breaker and determine cause for open circuit breaker.
* Applies only to airplanes that are in compliance with Part II Service Bulletin 866A and the back-up extension system is operational. § Applies to all airplanes.		

CHEROKEE ARROW III SERVICE MANUAL

TABLE VI-III. HYDRAULIC SYSTEM TROUBLESHOOTING (cont)

Trouble	Cause	Remedy
Landing gear extension system fails to operate. (cont)	<ul style="list-style-type: none"> § Landing gear selector circuit breaker open § Landing gear actuator circuit wires broken. § Landing gear selector circuit wires broken. § Pump extension solenoid inoperative (outboard solenoid). 	<ul style="list-style-type: none"> § Reset circuit breaker and determine cause for open circuit breaker. § Check wiring. § Check wiring. § Replace solenoid.
<p>NOTE</p> <p><i>If the extension solenoid of the pump can be heard to actuate when operating the gear selector switch, it may be assumed that the gear control circuit is operating properly and the actuator circuit should be further checked.</i></p>		
	<ul style="list-style-type: none"> § Gear selector switch ground incomplete. § Gear selector switch inoperative. § Hydraulic pump ground incomplete. § Hydraulic pump inoperative. § Hydraulic fluid in reservoir below operating level. § Low or dead battery. 	<ul style="list-style-type: none"> § Check ground. § Replace switch. § Check ground. § Replace or overhaul pump. § Fill reservoir with hydraulic fluid. § Check condition of battery.
§ Applies to all airplanes.		

CHEROKEE ARROW III SERVICE MANUAL

TABLE VI-III. HYDRAULIC SYSTEM TROUBLESHOOTING (cont)

Trouble	Cause	Remedy
Landing gear retraction extremely slow.	<ul style="list-style-type: none"> § Hydraulic Fluid in reservoir below operating level. § Restriction in hydraulic lines. § Shuttle valve sticking in pump base. 	<ul style="list-style-type: none"> § Fill reservoir with hydraulic fluid. § Isolate and check hydraulic lines. § Check cause.
Pump stops during gear retraction.	<ul style="list-style-type: none"> § Landing gear actuator circuit breaker opens. § Landing gear selector circuit breaker opens. § Pressure switch out of adjustment § Mechanical restriction or obstruction in hydraulic system to allow pressure to build up and shut off pump before gear has retracted. § Shuttle valve sticking in pump base. 	<ul style="list-style-type: none"> § Reset circuit breaker and determine cause for overload. § Reset circuit breaker and determine cause for overload. § Remove and readjust or replace switch. § Place airplane on jacks and run retraction check. Isolate and determine cause. § Check cause.
Pump stops during gear extension.	<ul style="list-style-type: none"> § Landing gear actuator circuit breaker opens. § Landing gear selector circuit breaker opens. 	<ul style="list-style-type: none"> § Reset circuit breaker and determine cause for overload. § Reset circuit breaker and determine cause for overload.
§ Applies to all airplanes.		

CHEROKEE ARROW III SERVICE MANUAL

TABLE VI-III. HYDRAULIC SYSTEM TROUBLESHOOTING (cont)

Trouble	Cause	Remedy
Pump fails to shut off though gear has fully retracted.	§ Pressure switch inoperative.	§ Replace switch.
	§ Pressure switch out of adjustment.	§ Replace switch.
	§ Pump retraction solenoid sticking (inboard solenoid).	§ Replace solenoid.
	§ Internal leakage of system.	§ Check back-up extension unit valve for internal leakage. § Check gear actuating cylinders for internal leakage.
	§ External leakage of system.	§ Check for internal damage to hydraulic pump. § Check back-up extension unit valve or free fall valve for external leakage. § Check gear actuating cylinders for external leakage.
	§ Pump relief valve out of adjustment.	§ Check for broken or damaged hydraulic lines or hoses. § Replace pump.
	Pump fails to shut off though the gear has full extended.	§ Pump extension solenoid sticking (outboard solenoid).
§ Applies to all airplanes.		

CHEROKEE ARROW III SERVICE MANUAL

TABLE VI-III. HYDRAULIC SYSTEM TROUBLESHOOTING (cont)

Trouble	Cause	Remedy
Pump fails to shut off though the gear has fully extended. (cont)	§ Nose gear down limit switch actuator out of adjustment.	§ Adjust switch actuator (Refer to Adjustment of Nose Gear Down Limit Switch, Section VII.)
	§ Nose gear down limit switch failed.	§ Replace switch.
	§ Main gear down limit switch out of adjustment.	§ Adjust switch (Refer to Adjustment of Main Gear Down Limit Switch, Section VII.)
	§ Main gear down limit switch failed.	§ Replace switch.
<p>NOTE</p> <p><i>The out of adjustment or failed switch may be determined by noting which down light is not lit.</i></p>		
Pump running intermittently after gear has retracted.	§ Leakage of high pressure check valve. § Internal leakage of system. External leakage of system.	§ Remove pump and replace check valve. § Check auxiliary free fall valve for internal leakage. § Check gear actuating cylinders for internal leakage. § Check back-up extension unit valve or free fall valve for external leakage § Check gear actuating cylinders for external leakage.
§ Applies to all airplanes.		

CHEROKEE ARROW III SERVICE MANUAL

TABLE VI-III. HYDRAULIC SYSTEM TROUBLESHOOTING (cont)

Trouble	Cause	Remedy
Pump running inter- mittently after gear has retracted. (cont)		§ Check for broken or damaged hydraulic lines.
Gear stops part way up, but pump continues to run.	§ Pump high pressure relief valve out of adjustment. § Internal leakage of system. § Hydraulic fluid in reservoir below operating level.	§ Replace pump. * Check back-up extension unit valve for internal leakage. § Check gear actuating cylinders for internal leakage. § Check for broken or damaged hydraulic lines. § Fill reservoir with hydraulic fluid.
All gears fail to free fall.	* Back-up extension unit valve fails to open. § Back-up free fall valve fails to open.	* Check unit and valve and replace. § Check valve and replace.
* Gear free falls at air speeds above that required.	* Back-up extender unit hydraulic valve fails to close.	* Check extender unit spring adjustment. * Check hydraulic valve for sticking open. * Check extender unit diaphragm for damage. * Check for restriction in air pressure and static lines.
* Applies only to airplanes that are in compliance with Part II of Service Bulletin 866A and the back-up gear extension system is operational. § Applies to all airplanes.		

CHEROKEE ARROW III SERVICE MANUAL

TABLE VI-III. HYDRAULIC SYSTEM TROUBLESHOOTING (cont)

Trouble	Cause	Remedy
<p>* Landing gear fails to operate at required speeds. (Gear up at 103 KIAS for PA-28R-201T or 95 KIAS for PA-28R-201, gear down at 78 KIAS for PA-28R-201T or 75 KIAS for PA-28R-201.)</p>	<p>* Manual control rod between override lever (manual extender) and rear seat rubbing or chafing on spar web where rod passes beneath the spar.</p> <p>* Friction or tight connection at any of the attachment points (pivot points) of the override lever or actuator arm.</p> <p>* Binding of diaphragm shaft caused by build up of sand or dirt.</p>	<p>* Form the rod to allow clearance through fill fore and aft travel.</p> <p>* Clean, free and lubricate all pivot points.</p> <p>* Clean all moving parts.</p>
<p>* Landing gear will not retract after selecting up at an airspeed above actuator speed. (Also upon trying to override it is found that only with a steady pressure can the override be activated. After gear does retract and the override lever (manual extender) is relaxed (approximately 11 to 15 seconds) the gear will fall free.)</p>	<p>* Restriction in pressure head of gear back-up extender actuator.</p>	<p>* Disconnect hoses at back-up extender and clean out hoses and head.</p>
<p>* Applies only to airplanes that are in compliance with Part II of Service Bulletin 866A and the back-up gear extension system is operational.</p>		

CHEROKEE ARROW III SERVICE MANUAL

TABLE VI-III. HYDRAULIC SYSTEM TROUBLESHOOTING (cont)

Trouble	Cause	Remedy
With gear selector down and three green lights on, gear unsafe light comes on or intermittently on.	§ Shorted gear up solenoid.	§ Replace solenoid.
With gear selector down and three green lights on, pump motor circuit breaker opens.	§ Shorted gear up solenoid.	§ Replace solenoid.
With gear unsafe light on, pump operates on and off.	§ Shorted gear down solenoid.	§ Replace solenoid.
With gear unsafe light on, pump motor circuit breaker opens.	§ Shorted gear down solenoid.	§ Replace solenoid.
* With override lever up, auto extension off light fails to operate.	* Auto extension off switch actuator out of adjustment. * Auto extension off switch failed. * Auto extension off flasher failed.	* Adjust switch Refer to Paragraph 6-2 for switch location by moving mounting bracket at attachment slot. Adjust switch until actuator is closed when emergency gear handle is in override position and open when handle is in neutral. * Replace switch. * Replace flasher.
* Applies only to airplanes that are in compliance with Part II of Service Bulletin 866A and back-up gear extension system is operational. § Applies to all airplanes.		

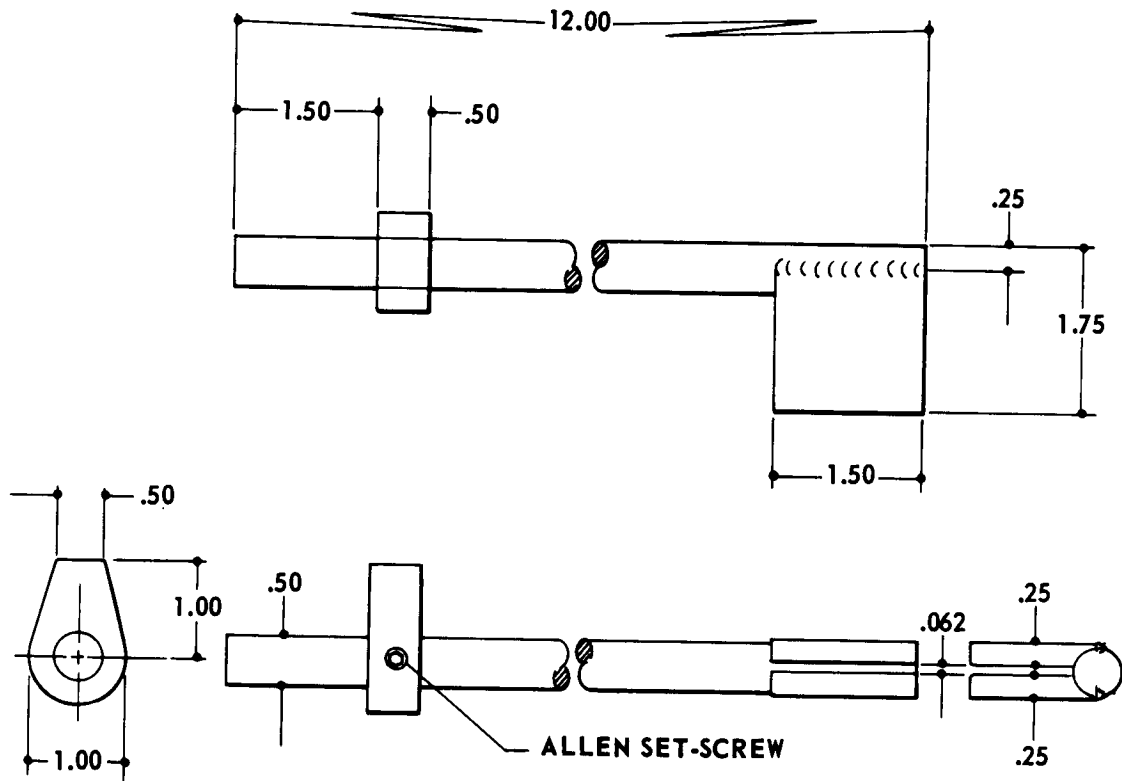

MATERIAL: Steel

NOTE

Use only on airplanes that are in compliance with Part II of Service Bulletin 866A and the back-up gear extension system is operational.

Figure 6- 10. Gear Back-Up Extender Actuator Aligning Tool

**GRIDS I120 AND I121
INTENTIONALLY LEFT BLANK**

SECTION VII
LANDING GEAR AND BRAKE SYSTEM

Paragraph	Aerofiche Grid No.
7-1. Introduction	1I24
7-2. Description	1I24
7-3. Troubleshooting.....	1J1
7-4. Landing Gear System.....	1J1
7-5. Nose Landing Gear.....	1J1
7-6. Disassembly of Nose Gear Oleo.....	1J1
7-7. Cleaning, Inspection and Repair of Nose Gear Oleo.....	1J2
7-8. Assembly of Nose Gear Oleo.....	1J2
7-9. Removal of Nose Landing Gear.....	1J5
7-10. Cleaning, Inspection and Repair of Nose Landing Gear.....	1J7
7-11. Installation of Nose Landing Gear	1J7
7-12. Adjustment of Nose Landing Gear (PA-28R-201).....	1J7
7-13. Adjustment of Nose Landing Gear (PA-28R-201T).....	1J11
7-14. Alignment of Nose Landing Gear	1J11
7-15. Removal of Nose Gear Door Assembly.....	1J20
7-16. Cleaning, Inspection and Repair of Nose Gear Door Assembly.....	1J20
7-17. Installation of Nose Gear Door Assembly.....	1J20
7-18. Adjustment of Nose Gear Doors	1J21
7-19. Main Landing Gear System.....	1J21
7-20. Disassembly of Main Gear Oleo	1J21
7-21. Cleaning, Inspection and Repair of Main Gear Oleo	1J22
7-22. Assembly of Main Gear Oleo.....	1J22
7-23. Removal of Main Landing Gear.....	1J23
7-24. Cleaning, Inspection and Repair of Main Landing Gear.....	1J23
7-25. Installation of Main Landing Gear.....	1J24
7-26. Adjustment of Main Landing Gear.....	1K1
7-27. Alignment of Main Landing Gear.....	1K3
7-28. Removal of Main Gear Door Assembly.....	1K4
7-29. Cleaning, Inspection and Repair of Main Gear Door Assembly.....	1K4
7-30. Installation of Main Gear Door Assembly	1K5
7-31. Adjustment of Main Gear Door Assembly.....	1K5
7-32. Landing Gear Limit Switches.....	1K5
7-33. Adjustment of Nose Gear Up Limit Switch.....	1K5
7-34. Adjustment of Nose Gear Down Limit Switch	1K6
7-35. Adjustment of Main Gear Up Limit Switch.....	1K6
7-36. Adjustment of Main Gear Down Limit Switch.....	1K7
7-37. Adjustment of Landing Gear Safety Switch (Squat Switch)	1K7
7-38. Adjustment of Gear Back-Up Extender Actuator Switch	1K7

Paragraph	Aerofiche Grid No.
7-39. Landing Gear Warning Switches (Throttle Switches).....	1K7
7-40. Landing Gear Up/Power Reduced Warning Switch.....	1K7
7-41. Removal of Landing Gear Up/Power Reduced Warning Switch.....	1K9
7-42. Installation of Landing Gear Up/Power Reduced Warning Switch.....	1K9
7-43. Adjustment of Landing Gear Up/Power Reduced Warning Switch.....	1K9
7-44. Wheels.....	1K10
7-45. Removal and Disassembly of Nose Wheel	1K10
7-46. Inspection of Nose Wheel Assembly	1K10
7-47. Assembly and Installation of Nose Wheel	1K10
7-48. Removal and Disassembly of Main Wheel.....	1K11
7-49. Inspection of Main Wheel Assembly.....	1K12
7-50. Assembly and Installation of Main Wheel.....	1K12
7-51. Brake System.....	1K13
7-52. Wheel Brake Assembly.....	1K13
7-53. Brake Adjustment and Lining Tolerance.....	1K13
7-54. Removal and Disassembly of Wheel Brake Assembly.....	1K13
7-55. Cleaning, Inspection and Repair of Wheel Assemblies	1K14
7-56. Assembly and Installation of Wheel Brake Assembly.....	1K14
7-57. Brake Master Cylinder (Hand Parking Brake).....	1K14
7-58. Removal of Brake Master Cylinder.....	1K14
7-59. Disassembly of Brake Master Cylinder.....	1K17
7-60. Cleaning, Inspection and Repair of Brake Master Cylinder.....	1K17
7-61. Assembly of Brake Master Cylinder.....	1K17
7-62. Installation of Brake Master Cylinder.....	1K17
7-63. Brake Cylinder (Toe Brake)	1K19
7-64. Removal of Brake Cylinder.....	1K19
7-65. Disassembly of Brake Cylinder.....	1K19
7-66. Cleaning, Inspection and Repair of Brake Cylinder.....	1K22
7-67. Assembly of Brake Cylinder.....	1K22
7-68. Installation of Brake Cylinder.....	1K22
7-69. Bleeding Brakes.....	1K22
7-70. Brake Bleeding Procedure (Gravity).....	1K22
7-71. Brake Bleeding Procedure (Pressure).....	1K23
7-72. Brake System Leak Check.....	1K24
7-73. Bleeding of the Brakes After a Unit Has Been Changed	1K24

SECTION VII

LANDING GEAR AND BRAKE SYSTEM

7-1. INTRODUCTION. In this section are instructions for the overhaul, inspection and adjustment of the various components of the landing gear and brake system. Also included are adjustments for the electrical limit, safety and warning switches. This section though does not cover the hydraulic function of the landing gear, except brakes, and this information may be found in the hydraulic section listed as Section VI.

7-2. DESCRIPTION. The airplanes are equipped with retractable tricycle air-oil strut type landing gear which are hydraulically operated by an electrically powered reversible pump. A selector handle on the instrument panel to the left of the control quadrant is used to select gear UP or DOWN positions.

Gear positions are indicated by three green lights located below the selector lever for gear down and locked, and a red light located at the top of the instrument panel for gear unsafe position. There is no light to indicate the gear has fully retracted other than all lights are out. As the landing gear swings to the down position and each downlock hook moves into its locked position, a switch at each hook actuates to the switch normally closed (NC) circuit to indicate by a green light that the individual gear is safely down and locked. The activation of all three downlock switches will also shut the hydraulic pump off. As the instrument lights are turned on, the green lights will dim. When the gear begins to retract and the downlock hook disengages, the down limit switch actuates to the NC circuit and in series with the NC circuit of the up limit switch allows the gear unsafe light to come on. The gear unsafe light will remain on until the gear is up and all up limit switches are actuated to their normally open (NO) circuit.

The red gear unsafe light also operates simultaneously with the warning horn, and in conjunction their purpose is to give warning when power is reduced below approximately 14 inches of manifold pressure and the landing gear has not reached the down and locked position. This circuit is controlled by the three paralleling down limit switches connected in series with a throttle switch (see Figure 7-15) located in the control quadrant. When the airplane is setting on the ground, the warning circuit is controlled through the NO side of the safety switch (squat switch) located on the left gear and the up position of the selector lever. Should the airplane be raised from the ground, such as in flight, far enough to move the safety switch to its NC position, then current is directed in series through the hydraulic pressure switch, the pump switch (providing airspeed has actuated the switch to its NO position). The up limit, safety, throttle, pressure and selector switch, and pump solenoids are all protected by the landing gear control and warning circuit protector. (Refer to Section XI for electrical schematic.)

Each landing gear is retracted and extended by a single hydraulic cylinder attached to the drag link assembly of the nose gear and the side brace link assembly of the main gears. As the gears retract, doors partially enclose each gear through mechanical linkage. The gears are held in their up position by hydraulic pressure along on the cylinder. There are no uplocks and loss of hydraulic pressure will allow the gears to drop. It is preferred that the gears be extended and retracted with the use of the gear selector handle; however in the event of hydraulic loss or electrical failure, they can be lowered by pushing down on the emergency extension lever between the pilot seats with or without the back-up gear extender system installed or disabled per compliance instructions of Piper Service Bulletin 866A, or they will drop themselves should airspeed drop below approximately 103 KIAS, engine power off for the PA-28R-201T and 95 KIAS, engine power off for the PA-28R-201 if the back-up gear extender system is operational per compliance instructions Part II of Service Bulletin 866A. In either instant the hydraulic valve of the back-up extender unit opens to allow hydraulic pressure to neutralize between each side of the cylinder pistons. The emergency extension lever can also be used

to manually overcome system malfunctions or to meet special pilot needs such as a deliberate wheels up landing needed for emergency landings on water, or during various flight maneuvers where airspeed and power settings would normally allow the gear to extend. It also permits gear retraction after takeoff at speeds lower than those normally permitted by the automatic system. When using the manual extension lever, the gear position is controlled by the selector switch, regardless of airspeed/power combinations. An override latch mechanism is installed which allows the pilot to latch the extension lever in the up override position, thus bypassing the automatic portion of the system on airplanes that have operational back-up gear extender systems. A flashing warning light is mounted below the gear selector lever to indicate whenever the latch is in use. The latch is disengaged by pulling up on the extension lever. To assist the nose gear to extend under these conditions are two springs, one inside the other, mounted on arms above the gear links. The main gears require no assist springs. Once the gears are down and the downlock hooks engage, a spring maintains each hook in the locked position until hydraulic pressure again releases it. A further description of the hydraulic system and the gear back-up extender unit may be found in Section VI, Hydraulic System.

The nose gear is steerable through a 60 degree arc by the use of the rudder pedals. As the gear retracts, however, the steering linkage becomes separated from the gear so that rudder pedal action with the gear retracted is not impeded by the nose gear operation. A shimmy dampener is also incorporated in the nose wheel steering mechanism. Bungee springs are also incorporated on the push rods. These springs make lighter and smoother ground steering possible.

The two main wheels are equipped with self-adjusting single disc hydraulic brake assemblies. Toe brakes are standard on both the pilot's and copilot's rudder pedals. A parking brake is incorporated with the handle, and may be used by pulling back on the handle and pushing forward on the button to the left of the handle. To release the hand brake, pull aft on the handle and allow it to swing forward. Hydraulic fluid for the cylinders is supplied by a reservoir installed on the left forward side of the firewall.

WARNING

Place airplane on jacks prior to troubleshooting landing gear system.

7-3. TROUBLESHOOTING. Mechanical and electrical switch troubles peculiar to the landing gear system are listed in Table VII-II at the back of this section. When troubleshooting, first eliminate hydraulic malfunctions as listed in Section VI. Then proceed to switch malfunctions and last to the mechanical operation of the gear itself, both of which are listed in this section. Always place the airplane on jacks before attempting any troubleshooting of the gear. To operate the gear, the emergency gear lever must be maintained in the up override position.

7-4. LANDING GEAR SYSTEM.

7-5. NOSE LANDING GEAR.

7-6. DISASSEMBLY OF NOSE GEAR OLEO. (Refer to Figure 7-1.) The nose gear oleo assembly may be removed and disassembled from the gear oleo housing with the gear removed from or installed on the airplane.

- a. Place the airplane on jacks. (Refer to Jacking, Section II.)
- b. Place a drip pan under the nose gear to catch spillage.
- c. Remove air and fluid from the oleo strut. Depress the air valve core pin until strut chamber pressure has diminished, remove the filler plug and with a small hose siphon as much hydraulic fluid from the strut as possible.
- d. To remove the complete cylinder and fork assembly from the oleo housing (21), cut safety wire (2) at the top of the unit and remove cap bolts (1) that attach steering arm (11) and aligner guide bracket (12) to the top of the oleo cylinder (23).
- e. Disconnect the shimmy dampener by removing each cotter pin, nut, washer and bolt that connects the dampener to the oleo cylinder (23) and housing.
- f. Release and remove the snap ring (17) and washer(s) (43), if installed, at the top of the housing (21), and pull the complete cylinder and fork assembly from the bottom of the housing. The upper and lower housing bushings (20 and 22) should remain pressed in the housing.

- g. To remove the piston tube (39) and fork (42) from the cylinder (23), first separate the upper and lower torque links (24 and 26) by removing the link connecting bolt assembly (25) and then separate the two links. Note spacer washer between the two links.
- h. Compress the piston tube (39), reach up along the tube and release the snap ring (38) from the annular slot at the bottom of the oleo housing.
- i. Pull the piston tube (39) with components parts from the cylinder.
- j. The piston tube components may be removed by reaching in the tube and pushing out the upper bearing retainer pins (27). Slide from the tube, the upper bearing (29), lower bearing (34) with outer and inner O-rings (33 and 35), wiper strip (36), washer (37) and snap ring (38).
- k. To remove the orifice tube (30), remove the large lock nut (16) and lock washer (19) from the top of the cylinder. Pull the tube from the cylinder.
- l. The orifice plate (31) is removed from the bottom of the orifice tube by releasing the snap ring (32) that holds the plate in position.
- m. To remove the piston tube plug (40) with O-ring (41) located in the lower end of the tube, remove the bolt assembly and insert a rod up through the hole in the body of the fork (42). Push the plug out through the top of the tube.

7-7. CLEANING, INSPECTION AND REPAIR OF NOSE GEAR OLEO.

- a. Clean all parts with a suitable dry type cleaning solvent.
- b. Inspect the landing gear oleo assembly component for the following:
 - 1. Bearings and bushings for excess wear, corrosion, scratches and overall damage.
 - 2. Retaining pins for wear and damage.
 - 3. Lock rings for cracks, bum, etc.
 - 4. Cylinder and orifice tube for corrosion, scratches, nicks and excess wear.
 - 5. Upper and lower cylinder bushings loose or turning in cylinder.
 - 6. Orifice plate for hole restriction.
 - 7. Fork tube for corrosion, scratches, nicks, dents and misalignment.
 - 8. Air valve general condition.
- c. Repair of the oleo is limited to smoothing out minor scratches, nicks and dents and replacement of parts.

7-8. ASSEMBLY OF NOSE GEAR OLEO. (Refer to Figure 7-1.)

- a. Ascertain that parts are cleaned and inspected.
- b. To install the piston tube plug (40), first lubricate the tube plug and O-ring (41) with hydraulic fluid (MIL-H-5606) and install the O-ring on the plug. Lubricate the inside wall of the tube (39), insert the plug into the top of the tube and push it to the fork end. Align the bolt holes of the fork, tube and plug, and install bolt assembly.
- c. If desired, cement a cork in the hole in the bottom of the fork body to prevent dirt from entering between the fork and tube.
- d. To assemble the components of the orifice tube (30), insert the orifice plate (31) into the bottom of the tube, with the countersunk side of the orifice hole exposed. Secure the plate with the snap ring (32), lubricate and install the O-ring (28) on the upper end of the tube.
- e. Insert the orifice tube (30) up through the bottom of the cylinder (23). With the tube exposed through the top of the cylinder, install the lock washer (19) and insert roll pin (18) through the lock washer into the piston. Install the tube lock nut (16) finger tight at this time.
- f. The fork (42) and tube (39) assembly may be assembled by installing the tube components on the tube. In order slide onto the tube, the snap ring (38), washer (37), lower bearing (34) with outer and inner O-rings (33 and 35) and upper bearing (29). Align the lock pin holes in the upper bearing with the pin holes in the piston tube (39) and install pins (27).

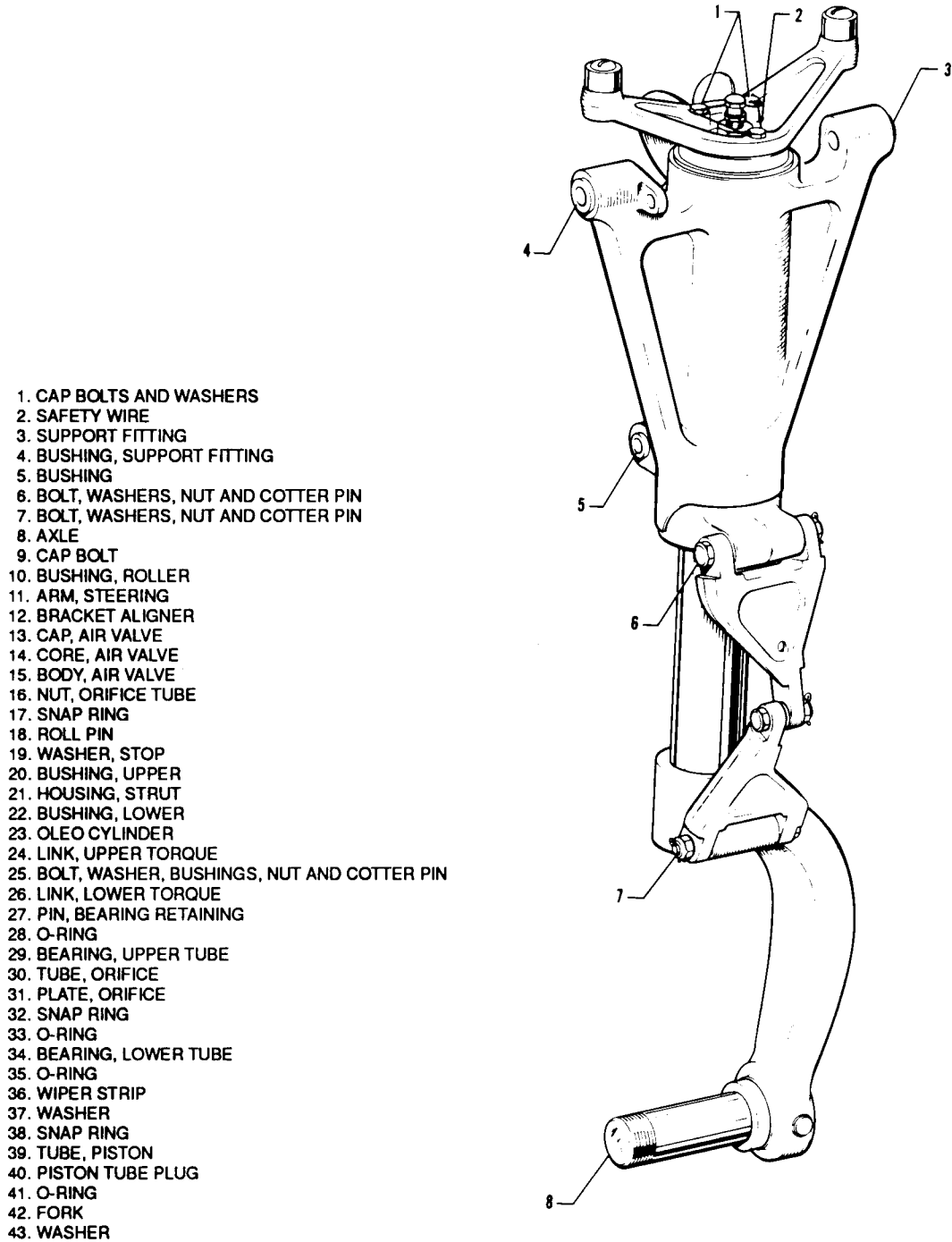
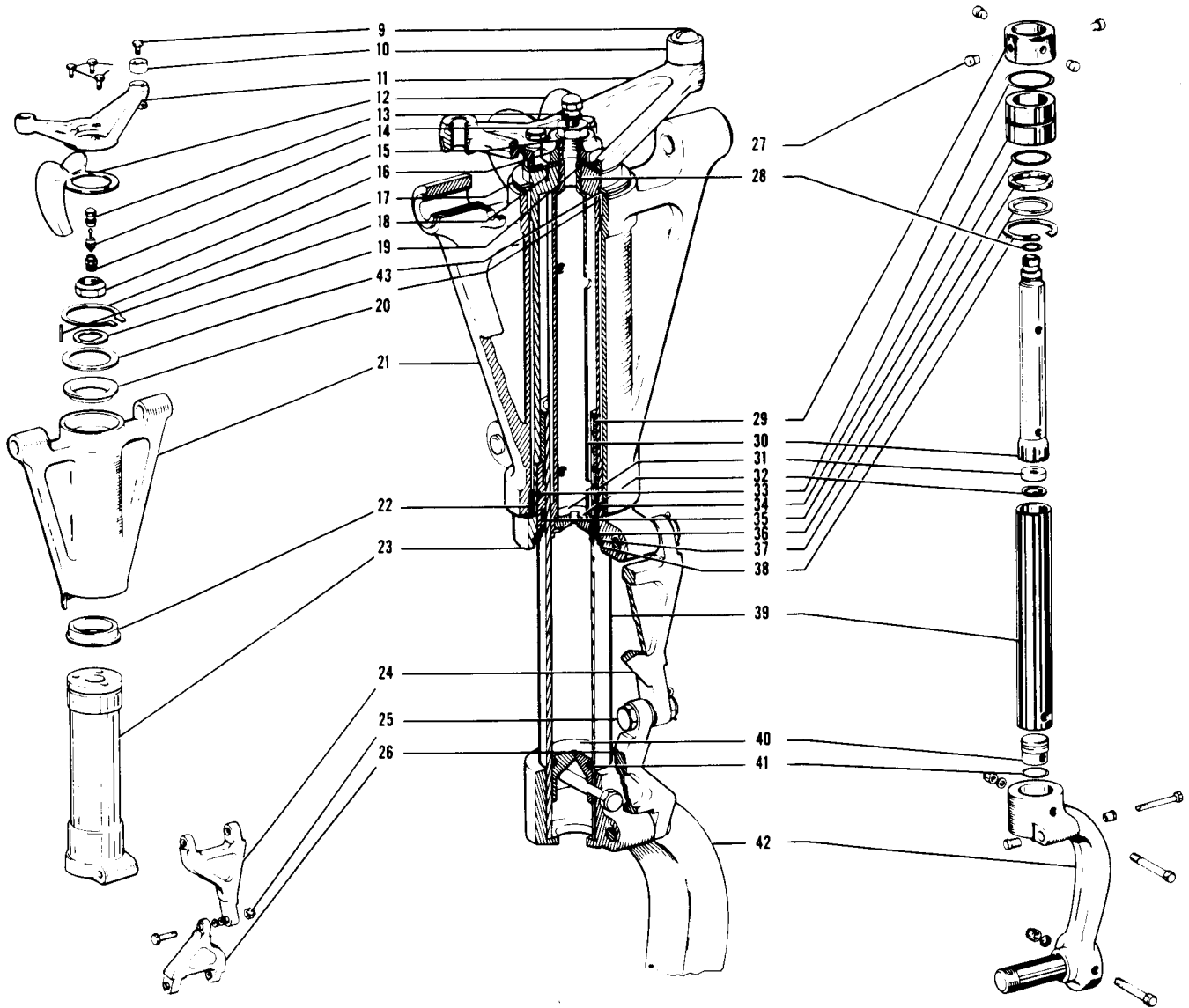

Figure 7- 1. Nose Gear Oleo Strut Assembly



NOTES

1. Torque nut (16) to 500 (min.) 600 (max.) inch pounds.
2. Apply thread lub 6 PB to threads of the air valve. Purchased from Parker.

Figure 7- 1. Nose Gear Oleo Strut Assembly (cont)

- g. Lubricate the inner wall of the cylinder (23) with hydraulic fluid. Carefully insert the piston tube assembly into the bottom of the cylinder, allowing the orifice tube to guide itself into the fork tube, until the snap ring (38) can be installed in the annular slot at the bottom of the cylinder. Install wiper strip (36), slide washer (37) into position and secure assembly with snap ring (38).
- h. At the top of the cylinder (23), tighten (torque) the orifice tube lock nut (16) to 500 (min.) 600 (max.) inch pounds.
- i. Ascertain that bushings are installed in the upper and lower torque links (24 and 26) and then install both links. The torque link bolt assemblies should be lubricated and installed with the flat of the bolt head hex adjacent to the milled stop on the wide end of the link. Tighten the bolts only tight enough to allow no side play in the link, yet be free enough to rotate.
- j. Ascertain that the upper and lower oleo housing bushings (20 and 22) are installed. Install the cylinder into the oleo housing, position spacer washer(s) (43) over the top of the cylinder and secure with snap ring (17). Install spacer washers as required to obtain .0 to .015 of an inch trust of the cylinder within the housing.
- k. At the top of the oleo housing, install on the cylinder the aligner guide bracket (12) and steering arm (11). Install cap bolts (1), tighten 20 to 25 inch pounds torque and safety with MS20995C40 wire (2).
- l. Install the shimmy dampener and safety.
- m. Lubricate the gear assembly. (Refer to Lubrication Chart, Section II.)
- n. Compress and extend the strut several times to ascertain that the strut will operate freely. Weight of the gear wheel and fork should allow the strut to extend.
- o. Service the oleo strut with fluid and air. (Refer to Oleo Struts, Section II.)
- p. (Check nose gear for alignment (refer to paragraph 7-13) and gear operation.

7-9. REMOVAL OF NOSE LANDING GEAR. (Refer to Figure 7-2.)

- a. Remove the engine cowling (refer to paragraph 8-14).
- b. Place the airplane on jacks. (Refer to Jacking, Section II.)
- c. Disconnect the two gear tension springs (15 and 17) from the spring arm (53) that is attached to the right side of the strut housing (39).
- d. Retract nose gear slightly to remove the gear from its downlocked position.
- e. To remove the upper and lower drag links (32 and 35), the following procedure may be used:
 - 1. Disconnect the rod end (44) of the hydraulic cylinder (47) from the downlock fitting (43) by removing nut and bolt that connects these two units.
 - 2. Retract the gear and disconnect the gear downlock spring (42) from the upper drag link (35).
 - 3. Remove the gear tension spring arm (40) from the right side of the oleo housing (39) and lower drag link (32) by removing the cotter pin, nut and washer from the bolt (29) that connects the drag link to the housing. Slide the arm and spacer washer from the bolt.
 - 4. Remove the cotter pins, washers and nuts from the bolts that secure the upper drag link (35) to the engine mount (36).
 - 5. Slide the attachment bolts from the upper and lower drag links and remove the links.
- f. With the lower drag link (32) disconnected from the gear oleo housing (39), the housing may be removed by removing cotter pins, nuts, washers, and bolts (7 and 33) at the attachment points on each side of the housing at the engine mount.
- g. The steering bellcrank (4) may be removed by removing the nut and bolt (3) at the steering rod, and the bolt assembly (13) with bushing at the bellcrank pivot point. (Note hardware position for reassembly.)

CHEROKEE ARROW III SERVICE MANUAL

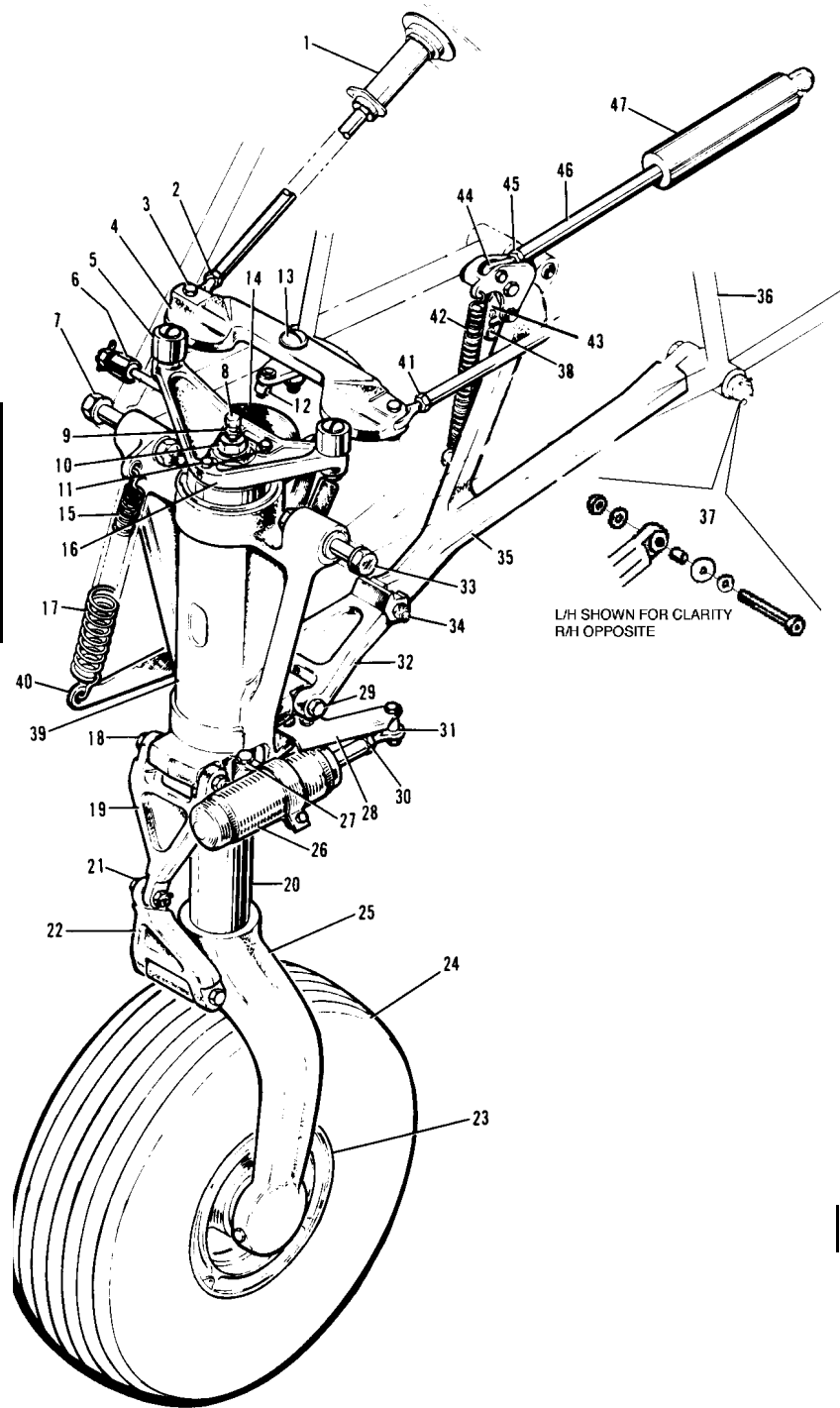

1. BUNGEE ASSEMBLY
2. JAM NUT
3. BOLT AND NUT ASSEMBLY IS INSTALLED ON PA-28-28R-201 WITH NUT DOWN. ON PA-28R-201T IT IS INSTALLED WITH NUT UP AND INCLUDES COTTER PIN.
4. STEERING BELLCRANK
5. BUSHING, STEERING ARM
6. BEARING, SPRING ROLLER
7. BOLT, WASHERS, NUT AND COTTER PIN
8. CAP, AIR VALVE
9. BODY, AIR VALVE
10. SAFETY WIRE
11. CAP BOLT AND WASHER
12. ROLLER, ALIGNER GUIDE
13. BOLT ASSEMBLY
14. BRACKET, ALIGNER
15. SPRING, INNER
16. ARM, STEERING
17. SPRING OUTER
18. BOLT, WASHERS, NUT AND COTTER PIN
19. LINK, UPPER
20. TUBE, PISTON
21. BOLT, WASHERS, NUT AND COTTER PIN
22. LINK, LOWER
23. WHEEL
24. TIRE
25. FORK
26. SHIMMY DAMPENOR
27. BOLT, WASHER, NUT AND COTTER PIN
28. BRACKET, SHIMMY DAMPENOR
29. BOLT, WASHERS, NUT AND COTTER PIN
30. JAM NUT
31. ROD END BEARING
32. DRAG LINK, LOWER
33. BOLT, WASHERS, NUT AND COTTER PIN
34. BOLT, WASHERS, NUT AND COTTER PIN
35. DRAG LINK, UPPER
36. ENGINE MOUNT
37. BOLT, WASHERS, BUSHING, SHOULDER BUSHING, NUT AND COTTER PIN
38. BOLT AND NUT
39. HOUSING, STRUT
40. ARM, SPRING
41. JAM NUT
42. SPRING, DOWNLOCK
43. FITTING, DOWNLOCK HOOK
44. ROD END BEARING
45. JAM NUT
46. ROD, ACTUATOR
47. CYLINDER, HYDRAULIC

Figure 7-2. Nose Gear Installation

7-10. CLEANING, INSPECTION AND REPAIR OF NOSE LANDING GEAR

- a. Clean all parts with a suitable dry type cleaning solvent.
- b. Inspect the gear components for the following unfavorable conditions:
 1. Bolts, bearings and bushings for excess wear, corrosion and damage.
 2. Gear housing, drag links, torque links, and tension spring arm for cracks, bends or misalignment.
 3. Downlock hook for excess wear of the hook and bearing surfaces.
 4. Downlock roller bearing for freedom of movement and excessive wobble.
- c. Inspect the gear tension and downlock hook springs for the following:
 1. Excess wear or corrosion, especially around the hook portion of the springs. A spring should be rejected if wear or corrosion exceeds one-quarter the diameter of the spring. Clean away all corrosion and repaint.
 2. Check the gear tension springs for load tensions below minimum allowable tolerances. The minimum allowable tension of the inner spring is 37 pounds pull at 13.75 inches and the outer is 60 pounds pull at 13.75 inches. Measurement is taken from the inner side of each hook. If it is found that either spring should be rejected, replace both springs.
 3. Check the gear downlock hook spring for load tension below minimum allowable tolerance. The minimum tension of the spring is 10.5 pounds pull at 4.5 inches. Measurement is also taken from the inner side of each hook.
- d. Check the general condition of each limit switch and its actuator, and wiring for fraying, poor connections or conditions that may lead to failures.
- e. Check drag link through center travel by attaching the upper and lower drag links, setting them on a surface table, and ascertaining that when the stop surfaces of the two links touch, linkage is not less than .062 to .125 nor more than .125 to .250 of an inch through center. Should the distance exceed the required through center travel and bolt and bushing are tight, replace one or both drag links.
- f. The shimmy dampener requires no service other than routine inspection. In case of damage or malfunction, the dampener should be replaced rather than repaired.
- g. Repair to the landing gear is limited to reconditioning of parts such as replacing bearings and bushings, smoothing out minor nicks and scratches, repainting of areas where paint has chipped or peeled and replacement of parts.

7-11. INSTALLATION OF NOSE LANDING GEAR. (Refer to Figure 7-2.)

NOTE

When assembling any units of the landing gear, lubricate bearings, bushings, and friction surfaces with the proper lubricant as described in Section II.

- a. Attach the steering bellcrank (4) with bushing to its mounting plate on the engine mount (36) securing with the bolt assembly (13). Align the steering bellcrank (4) and the steering arm bushings (5) by positioning the spacer washers as noted in removal. Connect the bungee assembly (1) to the bellcrank (4) and install bolt and nut assemblies (3). The adjustment, fore and aft of the bellcrank, may be made after the gear has been installed and rigged and adjusted.
- b. To install the gear housing assembly, position the gear so that the bolt attachment points on the housing (39), align with the attachment points on the engine mount (36). Install pivot bolts, washers and nuts (7 and 33). Tighten the nuts to a snug fit, yet allowing the gear to swing free, and safety.

- c. The drag links (32 and 35) and gear tension spring arm (40) may be installed by the following procedure:
 1. Ascertain that the upper and lower links (32 and 35) are assembled with the downlock hook attached and the through travel of the links checked according to Paragraph 7-10.
 2. Position the link assembly to allow the bolt holes in the links to align with the bolt holes in the gear housing and the engine mount. Install the link attachment bolts.
 3. Install nuts and washers on the upper link (35) attachment bolts. Tighten the nuts to allow the links to rotate freely and safety.
 4. Check alignment of the downlock hook to determine if it grips the roller bearing so as not to contact the bolt head, the bearing attachment block or washer. If the downlock hook is inboard, or it contacts the bolt head, shim between the bearing and the bearing attachment block with washer AN960-10L, not to exceed three. The bearing must be free to rotate.
 5. Install the gear tension spring arm (40) on the drag link bolt (29) on the right side of the gear oleo housing (39), secure and safety. A washer is installed on the bolt between the lower drag link and the arm.

NOTE: *During extension and retraction of the nose landing gear check the routing and security of the mixture cable to prevent interference between the cable and the nose gear linkage.*

- d. Retract and extend the landing gear several times to ascertain smoothness of operation. Also check that the drag link assembly falls into the through center-locked position.
 - e. Retract the gear and connect the gear downlock spring (42) between the downlock hook (43) and the upper drag link (35).
 - f. Extend the gear and connect the two gear tension springs (15 and 17) between the attachment point on the oleo housing (39) and the spring arm (40).
 - g. Ascertain that the landing gear is lubricated per Lubrication Chart, Section II.
 - h. Check adjustment of the gear per Paragraph 7-12 or 7-13.
 - i. Install engine cowling. (The cowl support jacks located at each forward side of the nose gear door hinges are adjusted down to contact the cowl surface after attaching screws are secure.)
 - j. Retract landing gear and check door operation as per Paragraph 7-18.
 - k. Check the alignment of the nose gear per Paragraph 7-14.
 - l. Ascertain that the landing gear is down and locked, then remove the airplane from jacks.
- 7-12. ADJUSTMENT OF NOSE LANDING GEAR (PA-28R-201). (Refer to Figure 7-3.) The gear up stop (4) is located just above the gear door retraction roller near the lower aft end of the engine.
- a. Remove the engine cowl. For removal instructions, refer to Paragraph 8A-14.
 - b. Place the airplane on jacks. (Refer to Jacking, Section II.)

NOTE: *Inspect the nose landing gear link and brace assembly, the aft attachment end of the nose actuator and the right front hat section fairing for cracks and loose rivets. Dye penetrant may be required. If any of these parts are cracked, remove and replace in accordance with the latest revision of Piper Service Bulletin 724.*

- c. Retract the landing gear by turning the master switch on, raising the emergency gear extension lever and moving the gear selector handle to the UP position. Retain the emergency extension lever in the UP override position.
- d. Check the adjustment of the gear up stop by placing a carpenter's square with the longest end along the bottom of the fuselage and the shortest end running up through the centerline of the wheel axle. Measure up along the square from the bottom of the fuselage 5.80 +/- .12 inches to determine if the center of the wheel axle meets this measurement. If this measurement is incorrect, extend the gear, loosen the jam nut (5) on the gear up stop, and make the required adjustment by turning the stop.

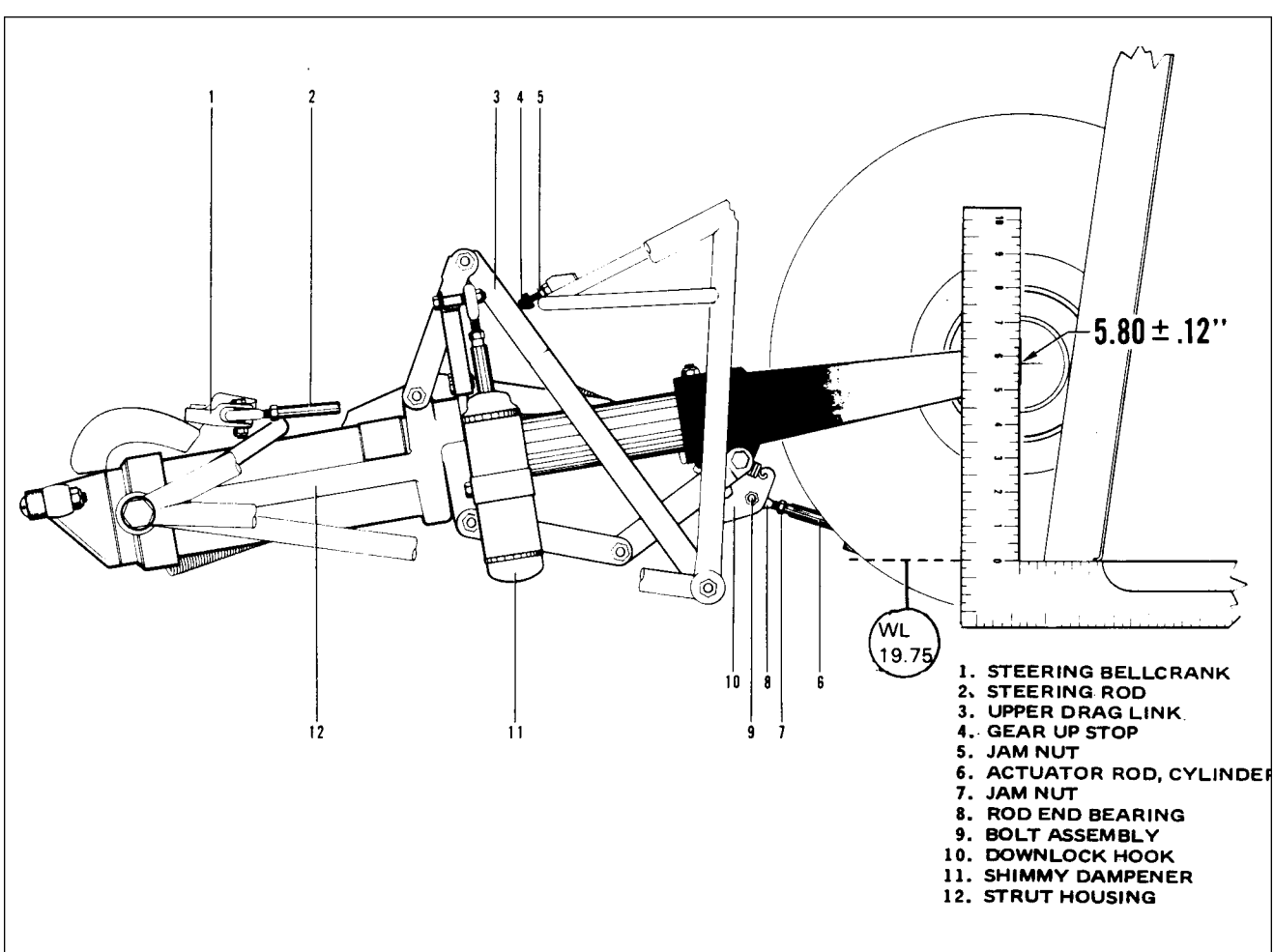
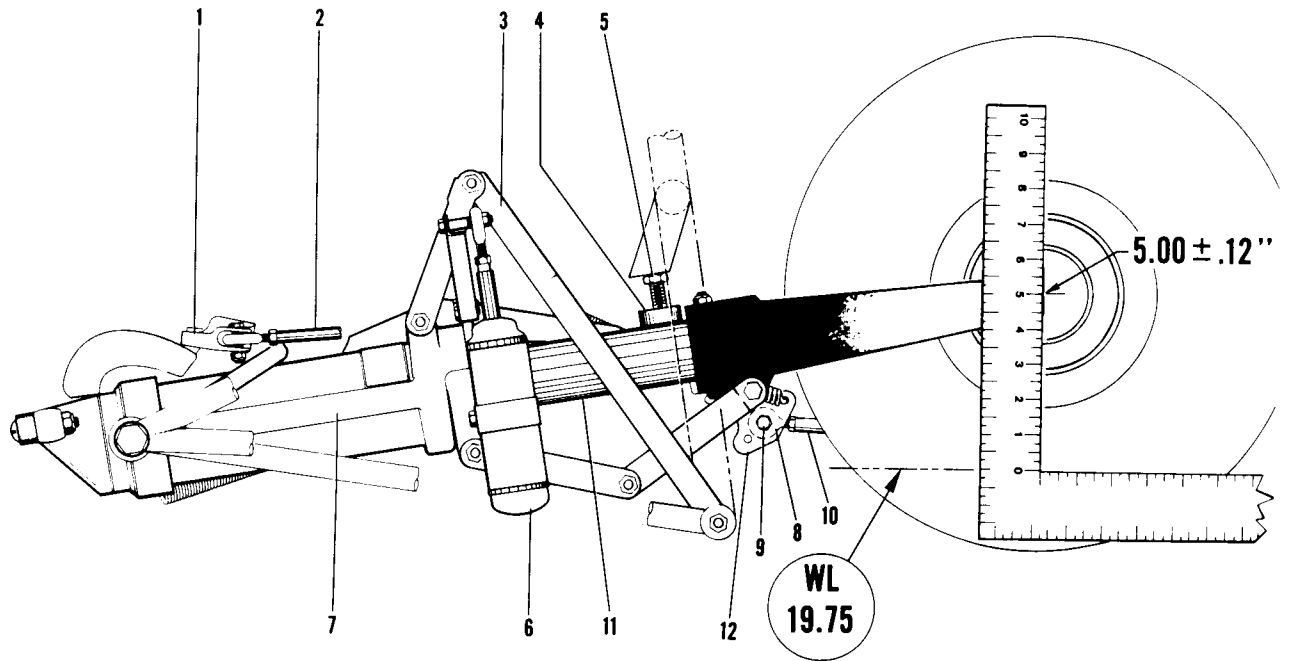

Figure 7-3. Nose Gear Adjustment (PA-28R-201)

- e. Check the adjustment of the hydraulic actuator rod by extending the gear and removing the nut and bolt (19) from the rod end bearing (8). Extend the actuator rod (6) to maximum then retract actuator rod (6) a minimum of .10 inch from the maximum extension. Try hooking rod end bearing with downlock hook (10), if connect can not be made, loosen the jam nut that secures the rod end bearing and turn rod end bearing until hook-up can be accomplished. Tighten jam nut and check that threads cover safety hole in actuator rod (6). Recheck .10 inch minimum rod travel remains to fill extension.
- f. Hook-up cylinder rod end bearing and retract gear. Recheck all adjustments and retighten the jam nut on the gear up stop. When the gear is fully retracted, the upper drag link (3) should be firmly against the gear up stop. Extend the gear.
- g. Adjust shimmy dampener by turning nose wheel against stops and adjusting the rod end of the dampener for adequate travel to both extremes.
- h. Install engine cowling, retract landing gear and check door per Paragraph 7-18.
- i. Ascertain that the landing gear is down and locked, then remove the airplane from jacks.



1. STEERING BELLCRANK
2. STEERING ROD
3. UPPER DRAG LINK
4. GEAR UP STOP
5. JAM NUT
6. SHIMMY DAMPENER
7. STRUT HOUSING
8. ROD END BEARING
9. BOLT ASSEMBLY
10. ACTUATOR ROD, CYLINDER
11. STRUT TUBE
12. DOWNLOCK HOOK

Figure 7-4. Nose Gear Adjustment (PA-28R-201T)

7-13. ADJUSTMENT OF NOSE LANDING GEAR (PA-28R-201T. (Refer to Figure 7-4.) The gear up stop (4) is located on the gear mount approximately 6 inches above the aft attachment point of the upper drag link (3).

- a. Remove the engine cowl. For removal instructions, refer to Paragraph 8-5.
- b. Place the airplane on jacks. (Refer to Jacking, Section II.)

NOTE

Inspect the nose landing gear link and brace assembly, the aft attachment end of the nose actuator and the right front hat section fairing for cracks and loose rivets. Dye penetrant may be required. If any of these parts are cracked, remove and replace in accordance with the latest revision of Piper Service Bulletin 724.

- c. Retract the landing gear by turning the master switch on, raising the emergency gear extension lever and moving the gear selector handle to the UP position. Retain the emergency extension lever in the UP override position.
- d. Check the adjustment of the gear up stop by placing a carpenters square with the longest end along the bottom of the fuselage and the shortest end running up through the center line of the wheel axle. Measure up along the square from the bottom of the fuselage 5.00 +/- .12 inches to determine if the center of the wheel axle meets this measurement. If this measurement is incorrect, extend the gear, loosen the jam nut (5) on the gear up stop, and make the required adjustment by turning the stop.
- e. Check the adjustment of the hydraulic actuator rod by extending the gear and removing the nut and bolt (9) from the rod end bearing (8). Extend the actuator rod (10) to maximum then retract actuator rod (10) from .33 to .53 inch from the maximum extension. Try hooking rod end bearing with downlock hook (12), if connection can not be made, loosen the jam nut that secures the rod end bearing and turn rod end bearing until hook-up can be accomplished. Tighten jam nut and check that threads cover safety hole in actuator rod (6). Recheck .33 to .35 inch rod travel remains to full extension.
- f. Hook-up cylinder rod end bearing and retract gear. Recheck all adjustments and retighten the jam nut on the gear up stop. When the gear is fully retracted, the strut tube (11) should be firmly against the gear up stop. Extend the gear.
- g. Adjust shimmy dampener by turning nose wheel against stops and adjusting the rod end of the dampener for adequate travel to both extremes.
- h. Install engine cowling, retract landing gear and check door per Paragraph 7-18.
- i. Ascertain that the landing gear is down and locked, then remove the airplane from jacks.

7-14. ALIGNMENT OF NOSE LANDING GEAR.

- a. Place the airplane on a smooth level floor that will accommodate the striking of a chalk line.
- b. Ascertain that the nose gear is properly adjusted in accordance with Paragraph 7-12 or 7-13.
- c. With the landing gear in the down-locked position, weight proportionally on the nose gear and the nose wheel facing forward, adjust the steering bellcrank. The bellcrank is attached at the lower front of the engine mount directly aft of the gear housing and may be adjusted by loosening its attachment bolt and sliding the bellcrank fore and aft until it clears each steering arm rollers by .03 of an inch. Retighten the attachment bolt.
- d. Place the airplane on jacks. (Refer to Jacking, Section II.)
- e. Level the airplane laterally and longitudinally. (Refer to Leveling, Section II.)
- f. From the center point of the tail skid, extend a plumb bob and mark the contact point on the floor.

*** CHEROKEE ARROW III SERVICE MANUAL**

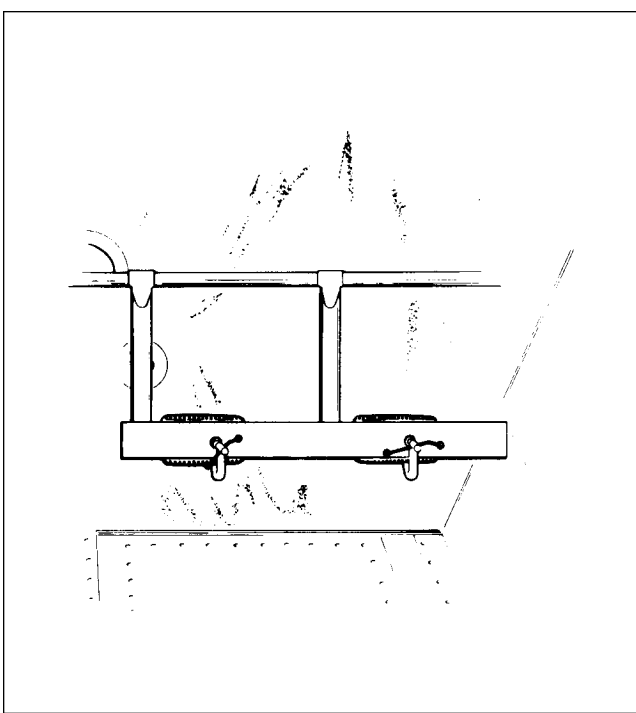

Figure 7-5. Clamping Rudder Pedals in Neutral Position

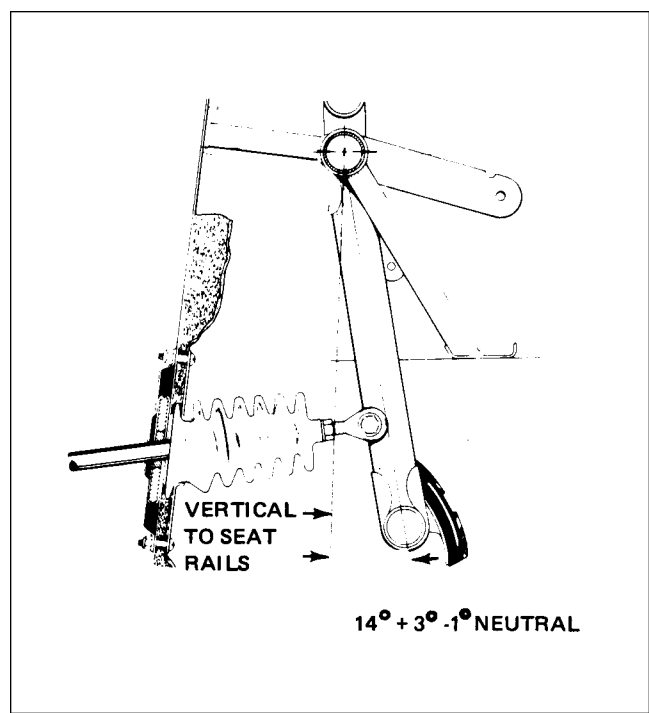
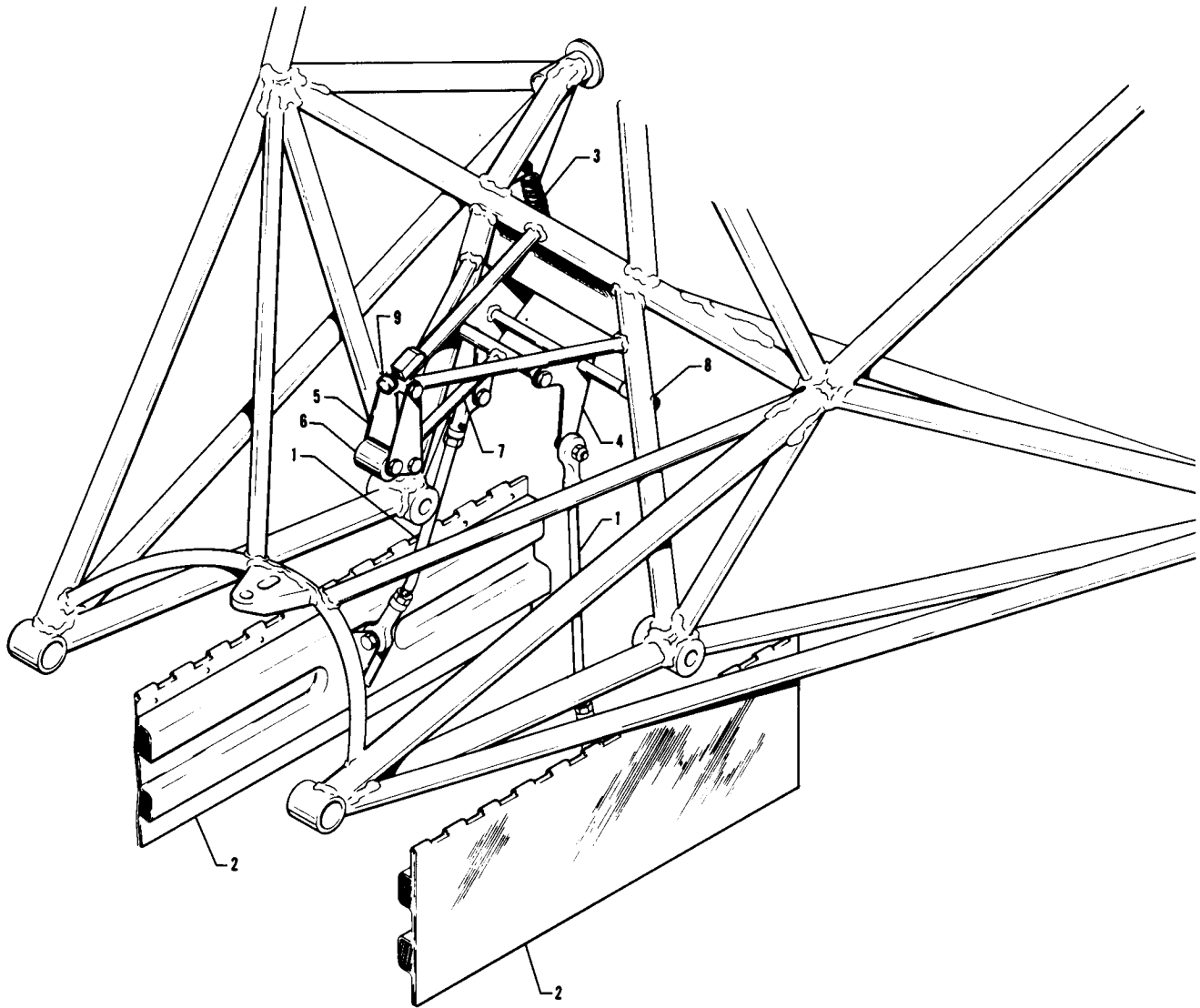

Figure 7-6. Rudder Pedals at Neutral Angle

- g. Extend a chalk line from the mark on the floor below the tail skid to a point approximately three feet forward of the nose wheel. Allow the line to pass under the wheel at the center line of the tire. Snap the chalk line.
- h. Clamp the rudder pedals to align them in a lateral position. Ascertain that the rudder pedals are in their neutral position. (Refer to Figure 7-6.)
- i. Adjust the rod end bearings of each steering control rod to align the nose wheel with the chalk line and to bring the rudder pedals into neutral angle fore and aft.
- j. Install the steering push rods on the pilot's rudder pedals. Adjust the rods so the lengths are both the same and the rudder pedals are at their neutral position.
- k. To align the nose wheel straight forward, stand in front of the nose gear and align the center rib of the tire with the chalk line, or lay a straight edge along the side of the tire and parallel the straight edge with the chalk line.
- l. Install the nose wheel bungees in their neutral position (no load on the bungee springs). Adjust bungee rod ends as necessary.
- m. Place a bubble protractor against a rudder pedal steering tube to check the neutral angle as shown in Figure 7-6.
- n. One end of each rod must be disconnected and the jam nuts loosened to make any adjustments. Do not attempt to make the adjustment by means of one rod end bearing, but divide the adjustment between the bearings at each end of each rod. Check that the rod ends have sufficient thread engagement by ascertaining that a wire will not go through the check hole in the rod. Reinstall the rods and tighten the jam nuts.
- o. To check the nose gear steering for its $30^\circ \pm 2^\circ$ maximum right and left travel, mark on each side of the nose wheel an angle line from the centerline and wheel pivot point. Turn the wheel to its maximum -travel in both directions to check for allowable travel. Should travel be exceeded in one direction and not enough in the other direction, check for possible damage to the gear fork or torque links.



- 1. ROD, DOOR RETRACTION
- 2. DOOR, GEAR
- 3. SPRING, TENSION
- 4. BELLCRANK ASSEMBLY
- 5. ROLLER ASSEMBLY
- 6. ROLLER
- 7. THREADED LINK, ROLLER
- 8. COTTER PIN
- 9. GEAR UP STOP

Figure 7-7. Nose Gear Door Retraction Mechanism (PA-28R-201)

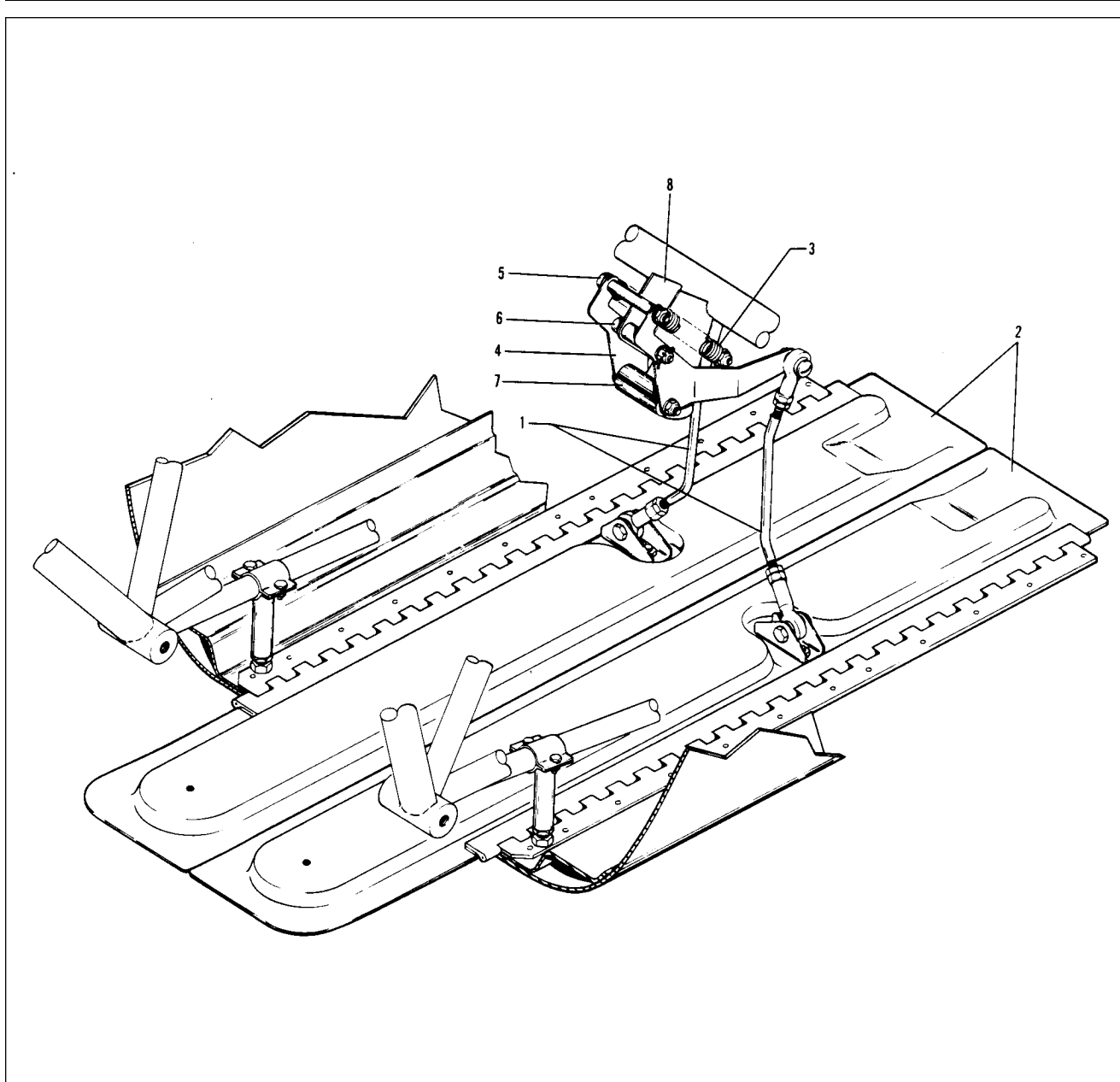

1. ROD, DOOR RETRACTION
2. DOOR, GEAR
3. SPRING, TENSION
4. ARM ASSEMBLY
5. BOLT & NUT
6. NUT, BOLT, WASHER, BUSHING & COTTER PIN
7. ROLLER
8. BRACKET

Figure 7-8. Nose Gear Door Retraction Mechanism (PA-28R-201T)

*** CHEROKEE ARROW III SERVICE MANUAL**

TORQUE NUT 300 TO 500 INCH POUNDS

TORQUE NUT 300 TO 500 INCH POUNDS

APPLY THREAD LUB L6 PB TO THREADS OF AIR VALVE. PURCHASED FROM PARKER.

APPLY THREAD LUB 6 PB TO THREADS OF AIR VALVE. PURCHASED FROM PARKER.

1. BRACKET, SWITCH ACTUATOR
2. BOLT, WASHERS, NUTS AND COTTER PIN
3. BOLT, WASHERS, NUT AND COTTER PIN
4. BOLT, WASHERS, NUT AND COTTER PIN
5. AXLE NUT
6. NUT
7. WASHER
8. RETAINER
9. O-RING
10. VALVE ASSEMBLY
11. HOUSING, OLEO STRUT
12. ORIFICE TUBE
13. PLATE, ORIFICE
14. SNAP RING
15. LINK ASSEMBLY, UPPER
16. LINK ASSEMBLY, LOWER
17. RETAINER PIN, BEARING
18. BEARING, UPPER
19. O-RING, OUTER
20. BEARING, LOWER
21. O-RING, INNER
22. WIPER STRIP
23. WASHER
24. SNAP RING
25. PISTON TUBE
26. PLUG
27. O-RING
28. FORK ASSEMBLY

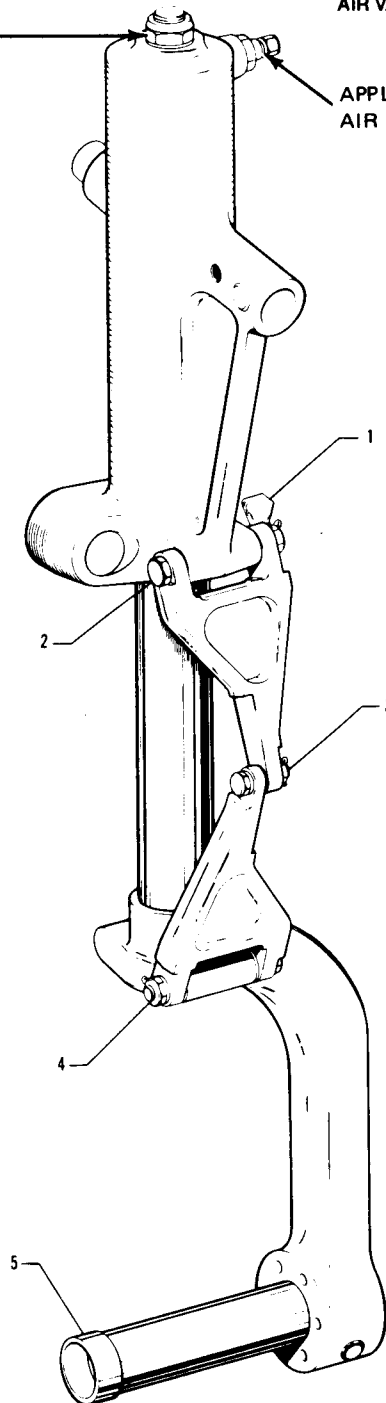
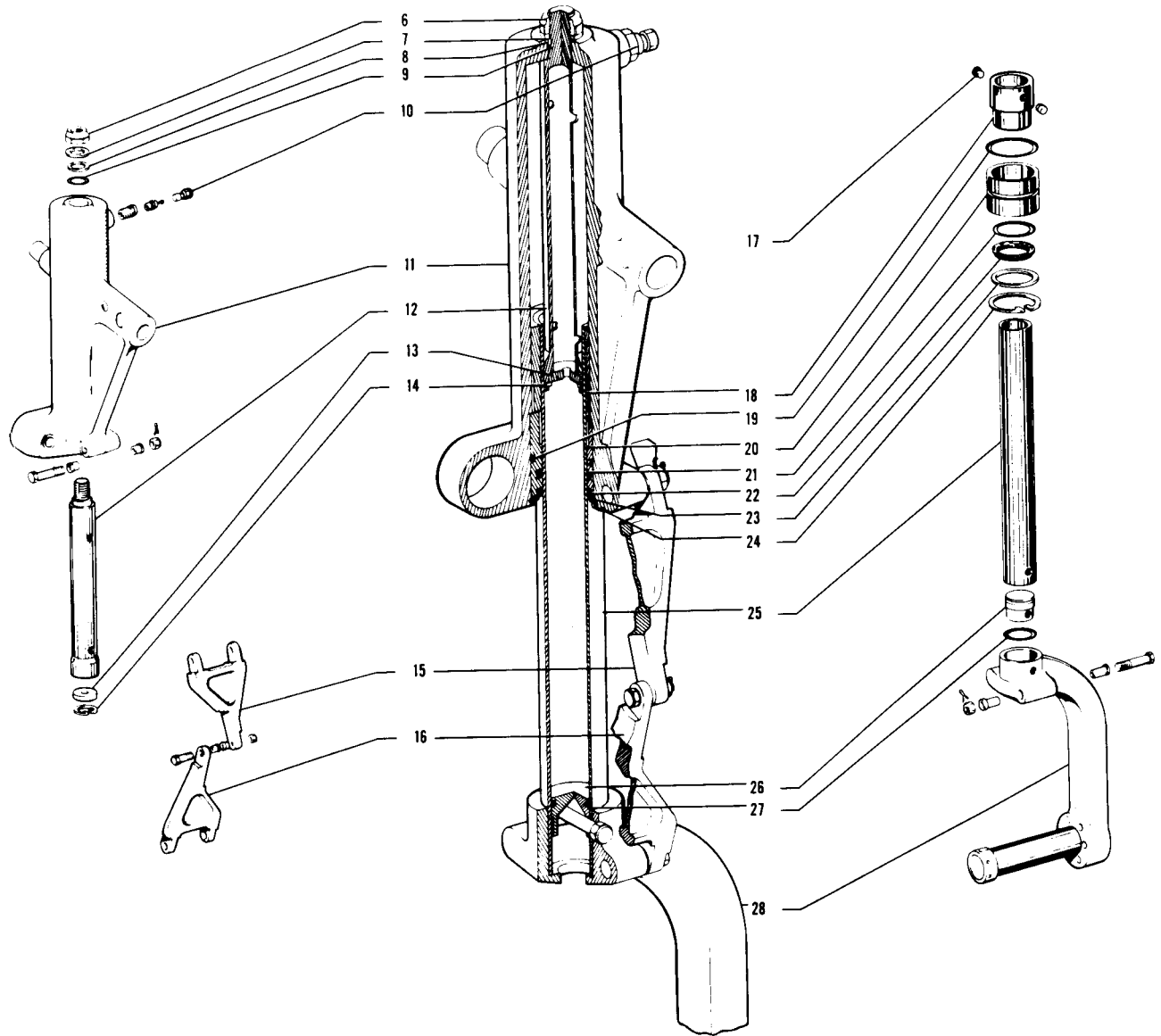
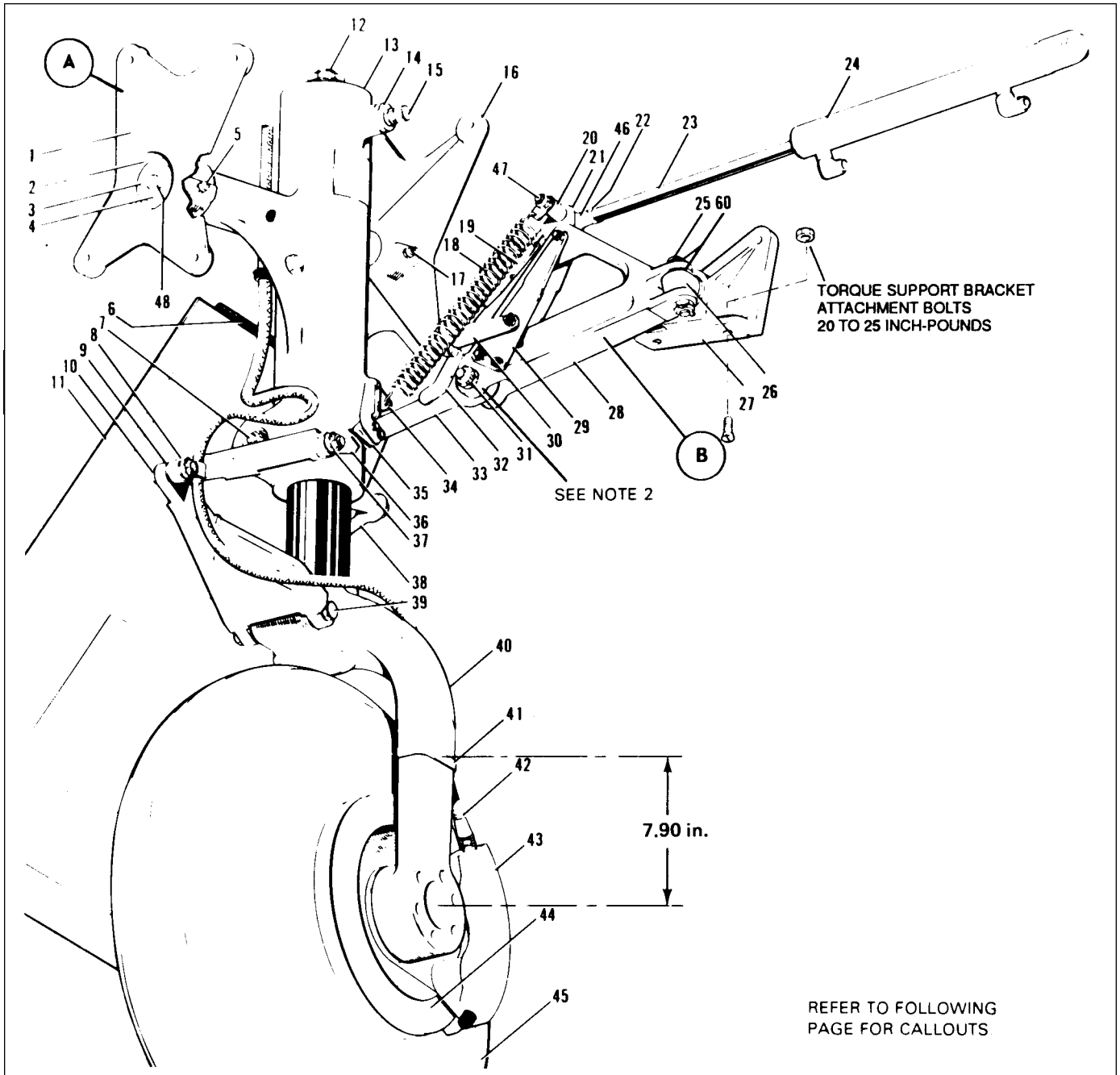

Figure 7-9. Main Gear Oleo Strut Assembly



REFER TO PRECEDING PAGE FOR CALLOUTS.

Figure 7-9. Main Gear Oleo Strut Assembly (cont)



NOTES

1. IT MAY HAVE BEEN NECESSARY TO USE SPECIAL LANDING GEAR ATTACHMENT HARDWARE DURING ASSEMBLY OF THE AIRCRAFT DUE TO MANUFACTURING TOLERANCES. THEREFORE, SPECIAL ATTENTION SHOULD BE GIVEN WHEN REMOVING HARDWARE TO INSPECT AND ENSURE THE SAME DIAMETER HARDWARE IS USED UPON REASSEMBLY. STANDARD AN4 OR AN5 BOLTS ARE REPLACED BY ALTERNATE OVERSIZED BOLTS NAS3004 OR NAS3005 RESPECTIVELY, WHEN OVERSIZED HARDWARE IS REQUIRED.
2. WHEN NEW BUSHINGS, P/N 14843-16, ARE INSTALLED, LINE BEAM I.D. TO .376/.375. BUSHINGS TO BE PRESS FIT AND IF LOOSE ON INSTALLATION, INSTALL WITH LOCTITE 601.

Figure 7-10. Main Gear Installation

* CHEROKEE ARROW III SERVICE MANUAL

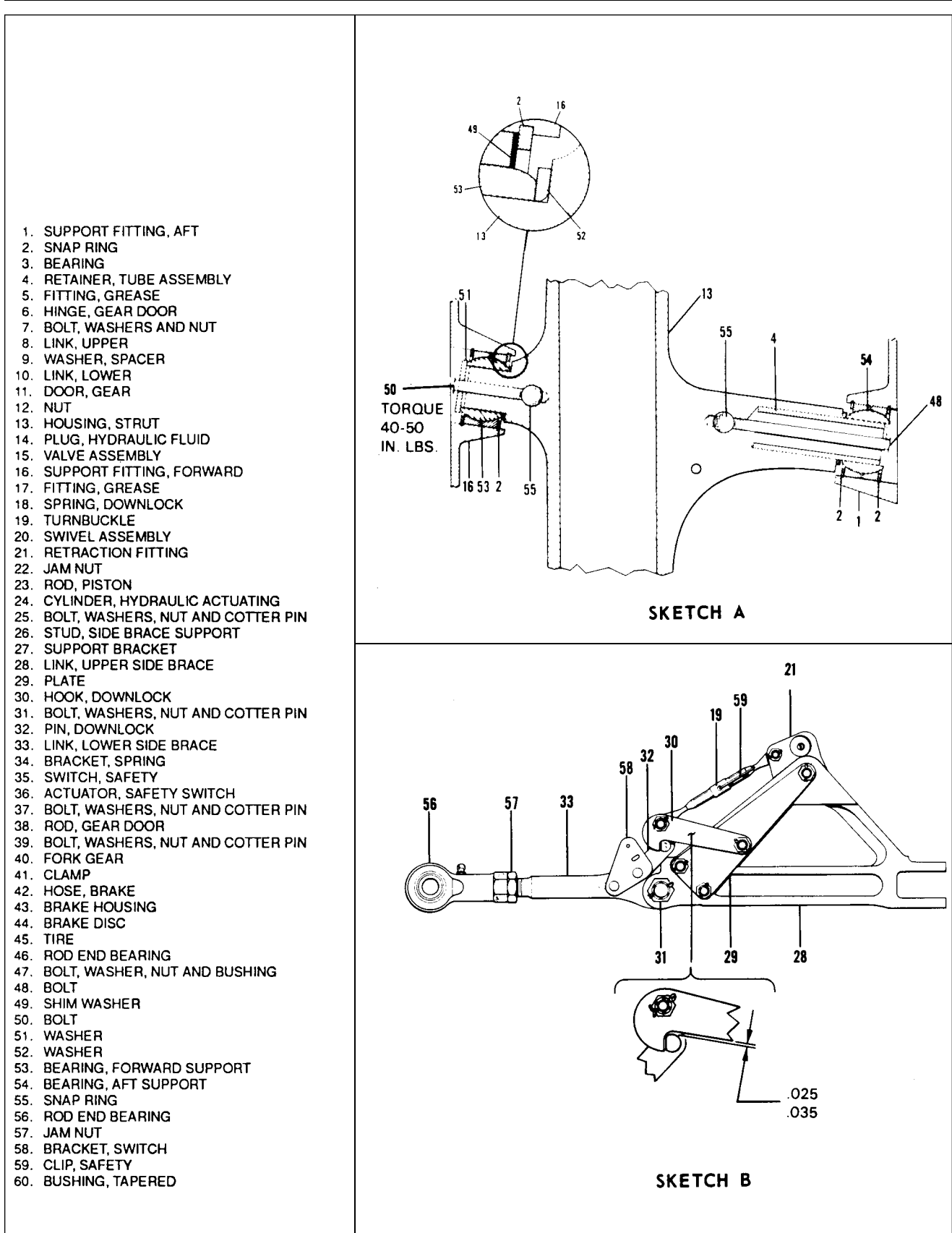

Figure 7-10. Main Gear Installation (cont)

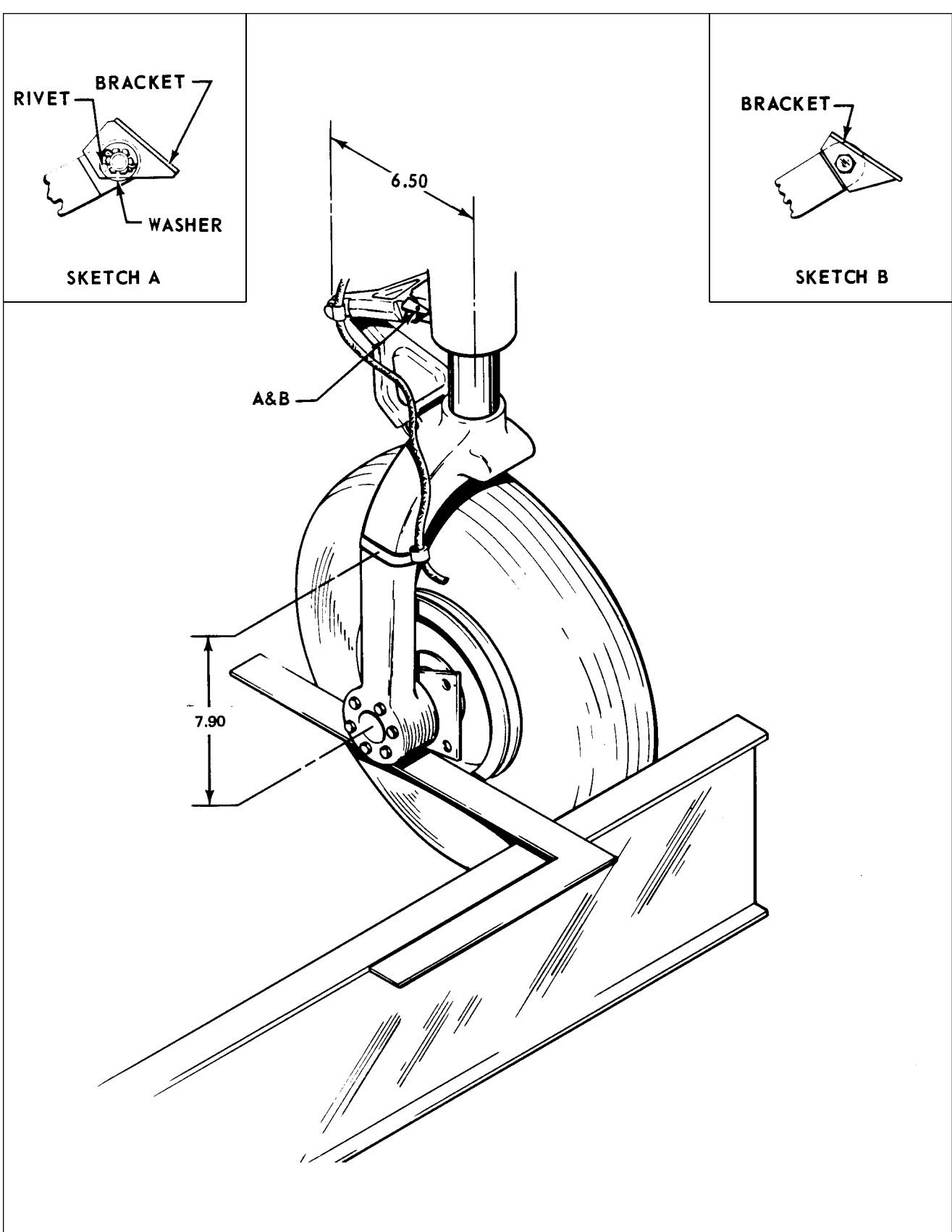

Figure 7-11. Aligning Main Gear

7-15. REMOVAL OF NOSE GEAR DOOR ASSEMBLY. (Refer to Figure 7-7 or 7-8.)

- a. The nose gear assembly on the PA-28R-201 may be removed as follows:
 1. With nose gear extended, disconnect the door retraction rods (1) from the doors (2) by removing nut, bolt and washers.
 2. To remove the door(s) from the cowl, bend one end of the hinge pin straight and from the other end pull out the pin. The bottom cowl may be removed to facilitate easier removal.
 3. Remove the bellcrank assembly (4) of the door retraction mechanism by removing the attached hardware, disconnecting the door down tension spring (3) and removing the cotter pins (8) at each end of the pivot tube. Slide the insulating sleeve and bushing tube from the bellcrank.
 4. Remove the roller assembly of the mechanism by removing the attached hardware and pivot bolt with insulator.
- b. The nose gear assembly on the PA-28R-201T may be removed as follows:
 1. With nose gear extended, disconnect the door retraction rods (1) from the doors (2) by removing nut, bolt and washers.
 2. To remove the door(s) from the cowl, bend one end of the hinge pin straight and from the other end pull out the pin.
 3. Remove the arm assembly by removing the upper arm assembly nut and bolt (5), carefully disconnecting the door down tension springs (3) and removing the cotter pin, nut, bolt, washer and bushings (6).
 4. Remove the roller (7) by removing the attached hardware and pivot bolt.

7-16. CLEANING, INSPECTION AND REPAIR OF NOSE GEAR DOOR ASSEMBLY.

- a. Clean all parts with a suitable cleaning solvent.
- b. Inspect doors for cracks or damage, loose or damaged hinges and brackets.
- c. Inspect door retraction rods for damage and rod end bearing for corrosion.
- d. Check the door tension springs for wear and tension below minimum allowable tolerance. Reject springs if load tension is below 8.0 pounds pull at 4.75 inches for the PA-28R-201 or below 20.0 pounds pull at 4.00 inches for the PA-28R-201T.
- e. Check general condition of bellcrank and roller assembly on the PA-28R-201 or the arm assembly and roller on the PA-28R-201T.
- f. Repairs to the doors may be replacement of hinges repair of aluminum or fiberglass and painting.
- g. Repairs to the retraction mechanism is limited to replacement of parts, sanding and painting.

7-17. INSTALLATION OF NOSE GEAR ASSEMBLY. (Refer to Figure 7-7 or 7-8.)

- a. The nose gear door assembly for the PA-28R-201 may be installed in the following manner:
 1. The roller assembly (5) of the retraction mechanism may be installed by first assembling the roller (6), threaded link (7) and roller links (5), and then installing this assembly on its mounting bracket. Ascertain that an insulator sleeve is installed with the attachment bolt and link bolt.
 2. The bellcrank assembly (4) of the retraction mechanism may be installed by positioning the bellcrank between its mounting bushing and inserting the insulator sleeve and bushing tube. Install a cotter pin through each attachment bushing and the pivot tube. New tubes will require a .070 hole drilled through each end to facilitate a cotter pin. Use the existing hole in the mounting bushings as a guide. Do not connect link between roller assembly and bellcrank until time of door adjustment.
 3. Install the gear door(s) by positioning the hinge halves of the door and cowl, and inserting the hinge pin. It is recommended a new pin be used. Bend the end of the pin to secure in place.
- b. Install the cowl and adjust doors as given in Paragraph 7-18.
 1. The roller (7) of the retraction mechanism may be installed on the arm assembly (4) with pivot bolt and nut.

2. The arm assembly may be installed by placing the arms on either side of the bracket (8) and securing with bolt, bushings, nut, washer and cotter pin (6).
3. Install the gear door(s) by positioning the hinge halves of the door and cowl and inserting the hinge pin. It is recommended a new pin be used. Bend the end of the pin to secure in place.
4. Install the cowl and adjust doors as given in Paragraph 7-18.

7- 18. ADJUSTMENT OF NOSE GEAR DOORS.

- a. Adjust PA-28R-201 nose gear doors as follows:
 1. Place the airplane on jacks. (Refer to Jacking, Section II.)
 2. Adjust the door retraction rods so that the gear will swing through the door opening with a .12 +/- .06 of an inch clearance between the gear and door at their closest point. This can best be done with the nose gear down, tension springs disconnected and operating the nose gear manually.
 3. With door clearance adjusted, adjust the link between the roller assembly and bellcrank assembly so that the doors will pull up tightly when gear is full up. Over tightening may result in door buckling, however if the link is too loose, doors will gap in flight.
 4. Check all rod ends for adequate thread engagement, for safety and tightness of jam nuts.
 5. Remove the airplane from jacks.
- b. Adjust PA-28R-201T nose gear doors as follows:
 1. Place the airplane on jacks. (Refer to Jacking, Section II.)
 2. Gear up stop must be properly adjusted per Paragraph 7-17 before rigging doors.
 3. Adjust the door actuator rods to fully close doors in the gear up position.
 4. Check all rod ends for adequate thread engagement, for safety and tightness of jam nuts.
 5. Remove the airplane from jacks.

7-19. MAIN LANDING GEAR SYSTEM.

7-20. DISASSEMBLY OF MAIN GEAR OLEO. (Refer to Figure 7-9.) The main gear oleo assembly may be removed and disassembled from the gear oleo housing with the gear removed from or installed on the airplane.

- a. Place the airplane on jacks. (Refer to Jacking, Section II.)
- b. Place a drip pan under the main gear to catch spillage.
- c. Remove the air and fluid from the oleo. To do this, depress the air valve core pin until strut pressure has diminished, remove the filler plug and with a small hose, siphon as much hydraulic fluid from the strut as possible.
- d. Disconnect the brake line at the joint located in the wheel well.
- e. To remove piston tube (25) assembly from oleo housing (11), remove the upper and lower torque link connecting bolt assembly (3) and separate the links. Note number and thickness of spacer washer(s) between the two links (15 and 16).
- f. Compress the piston tube (25), reach up along the tube and release the snap ring (24) from the annular slot at the bottom of the oleo housing.
- g. Pull the piston tube (25) with component parts from the cylinder housing.
- h. The piston tube (25) components may be removed by reaching in the tube and pushing out the upper bearing (18) retainer pins (17). Slide off the upper bearing (18), lower bearing (20) with O-rings (19 and 21), wiper (22), washer (23) and snap ring (24).
- i. To remove the orifice tube (12) from the oleo housing, remove the lock nut (6) and washer (7) from the top of the housing. Draw the tube with O-ring (9) and retainer (8) from the housing.
- j. The orifice plate (13) is removed from the bottom of the orifice tube (12) by releasing the snap ring (14) that holds the plate in position.
- k. To remove the piston tube plug (26) with O-ring (27) located in the lower end of the tube, remove the bolt assembly and insert a rod up through the hole in the body of the fork (28), pushing the plug out through the top of the tube.

7-21. CLEANING, INSPECTION AND REPAIR OF MAIN GEAR OLEO.

- a. Clean all parts with a suitable dry type cleaning solvent.
- b. Inspect the landing gear oleo assembly component for the following:
 1. Bearings and bushings for excess wear, corrosion, scratches and overall damage.
 2. Retaining pins for wear and damage.
 3. Lock rings for cracks, burrs, etc.
 4. Cylinder and orifice tube for corrosion, scratches, nicks and excess wear.
 5. Orifice plate for hole restriction.
 6. Fork tube for corrosion, scratches, nicks, dents and misalignment.
 7. Air valve general condition.
- c. Repair of the oleo is limited to smoothing out minor scratches, nicks and dents and replacement of parts.

7-22. ASSEMBLY OF MAIN GEAR OLEO. (Refer to Figure 7-9.)

- a. Ascertain that all parts are cleaned and inspected.
- b. To install the piston tube plug (26), first lubricate the plug O-ring (27) with hydraulic fluid (MIL-H-5606) and install it on the plug. Lubricate the inside wall of the tube. Insert the plug into the top of the tube (25) and push it to the fork end. Align the bolt holes of the fork, tube and plug, and install bolt assembly.
- c. If desired, cement a cork in the hole in the bottom of the fork body to prevent dirt from entering between the fork and tube.
- d. To assemble the components of the orifice tube (12), insert the orifice plate (13) into the bottom of the tube and secure with snap ring (14).
- e. To install the tube (12) in the oleo housing (11), insert the tube up through the housing. With the end of the tube exposed through the top of the housing, install the O-ring (9), retainer (8), washer (7), and locknut (6). Tighten locknut only finger tight at this time.
- f. Assemble the components of the piston tube (25) on the tube by placing, in order, the snap ring (24), washer (23), lower bearing (20) with outer and inner O-rings (19 and 21) and upper bearing (18). Align the two .125 diameter holes and the lock pin holes with the corresponding holes in the piston tube (25) and install pins (17) without force. The outer surface of the pins must not protrude beyond the outer diameter of the bearing (18).
- g. Lubricate the wall of the cylinder oleo housing (11) and tube (25) and carefully insert the tube assembly into the housing, guiding the orifice tube (12) into the piston tube until the snap ring (24) can be installed in the annular slot at the lower end of the housing. Install the wiper strip (22); slide the washer (23) into position and secure the assembly with snap ring (24).
- h. At the top of the housing, tighten the locknut (6), torque nut 300 min. to 500 max. inch pounds.
- i. Ascertain that the bushings are installed in the upper and lower torque links (15 and 16) and then install links. The torque link bolt assemblies (2, 3 and 4) should be lubricated and installed with the flat of the bolt head hex adjacent to the milled stop of the wide end of the link. (Use the same thickness of spacer washers between the two links as those removed to maintain correct wheel alignment.) Tighten the bolts only tight enough to allow no side play in the links, yet be free enough to rotate.
- j. Connect the brake line and bleed the brakes per Paragraph 7-73.
- k. Lubricate the gear assembly. (Refer to Lubrication Chart, Section II.)
- l. Compress and extend the strut several times to ascertain that the strut will operate freely. The weight of the gear wheel and fork should allow the strut to extend.
- m. Service the oleo strut with fluid and air. (Refer to Oleo Struts, Section II.)
- n. Check main gear alignment (refer to Paragraph 7-27) and gear operation.
- o. Remove the airplane from jacks.

7-23. REMOVAL OF MAIN LANDING GEAR. (Refer to Figure 7-10.)

- a. Place the airplane on jacks. (Refer to Jacking, Section II).
- b. The side brace link assembly may be removed by the following procedure:
 1. With the gear in the extended position, disconnect the gear downlock spring (18).
 2. Disconnect the rod end (46) of the actuating cylinder (24) from the retraction fitting (21) of the upper side brace link (28) by removing the nut, washer and bolt (47) with bushing and spring swivel (20).
 3. Disconnect the lower side brace link (33) from the gear housing (13) by removing the attachment nut, washer and bolt (7). Note bushings on each side of the end bearing.
 4. Disconnect the upper side brace link (28) from the side brace support fitting stud (26) by removing the cotter pin, nut, washer and attachment bolt (25).
 5. The side brace support fitting may be removed by removing the cap bolts that secure the fitting to the web of the spar.
 6. Remove the assembly and further disassemble and inspect as needed.
- c. The landing gear housing (13) with components may be removed by the following procedure:
 1. Disconnect the brake line (42) at its upper end in the wheel well.
 2. Disconnect the gear door actuating rod (38) at the gear housing.
 3. Remove the access plate located on the underside of the wing, aft of landing gear.
 4. If not previously disconnected, disconnect the lower side brace link (33) from the gear housing.
 5. Disconnect the forward support fitting (16) of the housing (13) from the web of the main spar by removing the fitting attachment bolts.
 6. Remove the retainer tube (4) in the aft support fitting (1) that supports the aft arm of the housing by reaching through the access opening on the underside of the wing, through the hole in the web and removing the bolt (48) that secures the tube in the housing. Insert a hook through the bolt hole in the tube and slide it aft from the support fitting. Remove the tube from the wing. Note the number of spacer washers (52) between the arm and support fitting (1).
 7. Allow the gear to drop down removing it from the wing.
 8. The aft support fitting (1) may be removed by holding the nuts, reaching through the access opening, and removing the fitting attachment bolts.
 9. The forward support fitting (16) may be removed from the arm of the housing by removing the bolt and washer from the base side of the fitting. Slide the fitting from the arm. Remove the washer (52) from the arm.
- d. Either bearing (53 and 54) installed in the support fittings may be removed by removing the snap rings (2) that hold the bearing in the housing. Push the bearing from the housing.

7-24. CLEANING, INSPECTION AND REPAIR OF MAIN LANDING GEAR.

- a. Clean all parts with a suitable dry type cleaning solvent.
- b. Inspect the gear components for the following unfavorable conditions:
 1. Bolts, bearing and bushings for excess wear, corrosion and damage.
 2. Gear housing, side brace links, torque links and attachment plates for cracks, bends or misalignment.
 3. Downlock hook for excessive wear of the bearing surfaces.
- c. Inspect the gear downlock spring for the following:
 1. Excessive wear or corrosion, especially around the hook portion of the spring. A spring should be rejected if wear or corrosion exceeds one-quarter the diameter of the spring. Clean away all corrosion and repaint.
 2. Check the spring for load tensions below minimum allowable tolerance. The minimum tension of the spring is 48 pounds pull at 7.9 inches. Measurement is taken from the inner side of each hook.

- d. Check the general condition of each limit switch and its actuator, and wiring for fraying, poor connections or conditions that may lead to failures.
- e. Check the side brace link through center travel by attaching the upper and lower links, setting them on a surface table and ascertaining that when the stop surfaces of the two links touch, linkage is not less than .062 nor more than .125 of an inch through center. Should the distance exceed the required through center travel and bolt and bushings are tight, replace one or both links.
- f. With the side brace links assembled and checked, ascertain that when the stop surfaces of the two links contact, the clearance between each downlock hook and the flat of the downlock pin is not less than 0.010 of an inch. Should clearance be less than that required, the hook only may be filed not to exceed a gap of more than 0.025 of an inch. The maximum allowable clearance between each hook and the downlock pin that are service worn is 0.055 of an inch. Should clearance be more than 0.055 of an inch, replace the pin, check clearance and then if still beyond tolerance, replace hooks. The gap between each hook should be equal.
- g. Repair of the landing gear is limited to reconditioning of parts such as replacing components, bearings and bushings, smoothing out minor nicks and scratches and repainting areas where paint has chipped or peeled.

7-25. INSTALLATION OF MAIN LANDING GEAR. (Refer to Figure 7-10.)

NOTE

When assembling components of the landing gear, lubricate bearings, bushings and friction surfaces with proper lubricant as described in Section II.

- a. Insert a gear support bearing (53 or 54) in each support fitting (1 or 16) and secure with snap ring (2). Check bearing (53) for excess end play, shim as necessary with shim washers (49) (P/N 162833-44).
- b. The gear housing may be installed in the wheel well of the wing by the following procedure:
 - 1. Place a spacer washer (52) and then the forward support fitting (16) on the forward arm of the housing. Ascertain that the barrel nut (55) is positioned in the arm and insert the attachment bolt through washer (51) and the fitting into the arm. Tighten bolt and ascertain that the bearing is free to rotate.
 - 2. Position the aft support fitting (1) at its attachment point in the wheel well and secure with bolts, washers and nuts. Install the nuts and washers by reaching through the access hole on the under side of the wing.
 - 3. With the retainer tube (4) for the aft arm of the housing in hand, reach up through the access opening and insert the tube into the support fitting (1) through the hole in the web.
 - 4. Position the gear housing up in the wheel well and install the forward support fitting (16) bolts and washers. (One each AN960-416 and AN960-416L washer-per bolt.)
 - 5. Push the retainer tube into the arm of the housing and secure with bolt. Torque to 40-50 in. lbs.
 - 6. Check that the gear rotates freely in its support fittings and recheck thrust.
 - 7. Connect the brake line to its mating line in the wheel well and bleed brakes as given in Paragraph 7-73.
- c. The gear side brace link assembly may be installed by the following procedure:
 - 1. Position the link support bracket (27) with swivel stud (26) installed at its attachment point on the web of the spar and secure with bolts and washers.

NOTE

When installing a new wing, it will be necessary to back drill two (2) holes 0.250 inch and countersink 100° x .499 through the spar cap. (Screw head should be flush with spar.) Use hole in the support bracket has a guide in the drilling.

2. Ascertain that the upper and lower links (28 and 33) are assembled with downlock hook (30), retraction fitting (21), etc. attached, and the through travel of the links and downlock hook clearance checked according to Paragraph 7-24.
 3. Attach the upper link to the swivel stud of the support fitting and secure with bolt, bushing, washer, nut and cotter pin.
 4. The actuating cylinder rod end bearing (46) and lower side brace link (33) may be attached respectively to the retraction fitting (21) and gear housing during the adjustment of the landing gear.
- d. Ascertain that the landing gear is lubricated per Lubrication Chart.
 - e. Check adjustment of the landing gear per Paragraph 7-26.
 - f. Check alignment of the wheel per Paragraph 7-27.
 - g. Install the access plate on the underside of the wing and remove the airplane from jacks.

7-26. ADJUSTMENT OF MAIN LANDING GEAR.

- a. Place the airplane on jacks. (Refer to Jacking, Section II.)
- b. Level the airplane laterally and longitudinally. (Refer to Leveling, Section II.)
- c. Disconnect the gear door actuating rods at either the door or the housing, as desired, by removing the rod attachment bolt. Secure the door out of the way.
- d. Adjust the gear oleo housing to obtain a vertical position with the airplane level (90 degrees to horizontal). To do this, set 90 degrees on a bubble protractor, place the protractor along the side of the gear piston tube and adjust the end bearing of the lower side brace link allowing the bubble of the protractor to center when the end bearing is connected to the gear housing. This should allow an angle of 83 +/- 1/2 degrees between the gear housing and the spar cap of the wing. Place a bushing on each side of the end bearing and secure with bolt, washer and nut.
- e. Check that the rod end has sufficient thread engagement in the end bearing, align the flat sides of the bearing casting with the flat side of the bearing and tighten the jam nut.

NOTE

With reference to the lower and upper side brace links, a maximum of .026 inch end play is allowed considering a load of 30 +/- 5 lbs. applied at the wheel axle with the strut completely extended. The load should be applied inboard and outboard to obtain maximum movement for determination of end play.

- f. Adjust the turnbuckle of the downlock mechanism by first ascertaining that the gear is down and locked and then move the retraction fitting outboard until it contact the stop slot of the side brace link. Hold the fitting in this position and turn the turnbuckle barrel until the downlock hooks make contact with the lock pin. Safety the turnbuckle.
- g. For easier adjustment of the downlock limit switch, it may be set at this time as given in Paragraph 7-36.
- h. Retract and extend the gear manually several times to ascertain that the side brace link falls through center, the downlock hook falls into position and there is no binding of the gear assembly.
- i. The gear should be adjusted in the up position to allow the gear fork to press lightly into the rubber bumper pad on the wing. The adjustment may be accomplished as follows:

NOTE

If it requires less than .025 of an inch to move the gear into the correct adjustment, steps 2 and 6 thru 8 need only be followed.

- 1. Ascertain that the rod end bearing of the actuating cylinder is disconnected from the retraction fitting.
- 2. Actuate the hydraulic system to bring the hydraulic cylinder to the up position by turning the master switch on, raising the emergency gear extension lever and moving the gear selector handle to the up position. Retain the emergency extension lever in the up override position. The piston of the cylinder should be bottomed. The retracted length of the cylinder is 10.92 inches.
- 3. Raise the gear by pushing up on the retraction fitting, thus disengaging the hooks, and pushing up on the pivot point at the bottom of the side brace links to bring the links out of the locked position. Raise the gear until the fork presses lightly into the rubber pad. Retain the gear in this position.
- 4. Loosen the jam nut on the piston rod of the actuating cylinder and turn the rod end bearing in or out to allow a slip fit of the attachment bolt.
- 5. Install with the attachment bolt, bushing, spring swivel and secure with washer and nut. Install the gear downlock spring.
- 6. When the gear is to within .125 of an inch of correct adjustment, the rod end need not be disconnected and therefore all that will be required is to loosen the jam nut, place a wrench on the flat at the end of the piston rod and turn to obtain correct adjustment.
- 7. Check the rod end bearing for adequate thread engagement and tighten jam nut.
- 8. If the downlock limit switch is properly adjusted, retract and extend the gear hydro-electrically to ascertain that the gear operates properly.

7-27. ALIGNMENT OF MAIN LANDING GEAR

- a. Place a straightedge no less than twelve feet long across the front of both main landing gear wheels. Butt the straightedge against the tire at the hub level of the landing gear wheels. Jack the airplane up just high enough to obtain a six and one-half inch dimension between the centerline of the strut piston and the centerline of the center pivot bolt of the gear torque links. (Refer to Figure 7-11.) Devise a support to hold the straightedge in this position.
- b. Set a square against the straightedge and check to see if its outstanding leg bears on the front and rear side of the brake disc. (It may be necessary to remove the brake assembly to have clear access to the disc.) (Refer to Figure 7-11.) If it touches both forward and rear flange, the landing gear is correctly aligned. The toe-in for the main landing gear wheels is 0 +/- 1/2 degrees.

NOTE

A carpenter's square, because of its especially long legs, is recommended for checking main landing gear wheel alignment.

- c. If the square contacts the rear side of the disc, leaving a gap between it and the front flange, the wheel is toed-out. If a gap appears at the rear flange, the wheel is toed-in.
- d. To rectify the toe-in or toe-out condition, remove the bolt connecting the upper and lower torque links and remove or add spacer washers to move the wheel in the desired direction. Refer to the chart on the following page.
- e. Should a condition exist that all spacer washers have been removed and it is still necessary to move the wheel further in, then it will be necessary to turn the torque link assembly over. This will put the link connecting point on the opposite side allowing the use of spacers to go in the same direction.
- f. Recheck wheel alignment. If the alignment is correct, safety the castellated nut with cotter pin.
- g. If a new link on the top left main gear had to be installed or it had to be reversed during the alignment check, it will be necessary to check the gear safety switch (squat switch) bracket for engagement and locking in place. If the large machine surface of the link is inboard, the bracket is mounted with the small rivet hole next to link. (Refer to Sketch A, Figure 7-11.) This should be aligned on the centerline of link and hole drilled to .096 of an inch, .15 of an inch deep. Insert an MS20426AD3-3 rivet in the hole. This locking rivet is held in place by the flat washer, castellated nut and cotter pin. If link has to be reversed, then the bracket and bolt are also reversed. (Refer to Sketch B, Figure 7-11.)
- h. Check adjustment of landing gear safety switch (squat switch) per Paragraph 7-37.

*** CHEROKEE ARROW III SERVICE MANUAL**

TABLE VII-I. TOE-IN—TOE-OUT CORRECTION CHART

TOE-IN TOE-OUT ANGLE	SHIM WASHERS	WASHERS UNDER HEAD	WASHERS UNDER NUT	AN 174 BOLT
0°		AN960-416	AN960-416 (3)	-14
0°33'	AN960-416	AN960-416	AN960-416 (2)	-14
0°48'	AN960-416L	AN960-416	AN960-416	-14
	AN960-416			
1 °04'	AN960-416 (2)	AN960-4 16	AN960-416	-14
1 °19'	AN960-416L	AN960-416L	AN960-416	-14
	AN960-416 (2)			
1°35'	AN960-416 (3)	AN960-416	AN960-416 (2)	-15
2°05'	AN960-416 (4)	AN960-416	AN960-416	-15
Max. Allow.				.
AN960-416L Washers .031 Thick AN960-416 Washers .062 Thick				

7-28. REMOVAL OF MAIN GEAR DOOR ASSEMBLY.

- a. With the landing gear extended, disconnect the door retraction rod from the door by removing nut, washers and bolt.
- b. Remove the door from the wing panel by bending the door hinge pin straight and from the other end pulling out the pin.
- c. The door retraction rod may be removed from the gear housing by cutting the safety wire and removing the attachment bolt and washer. Note the number of washers between rod end bearing and housing.

7-29. CLEANING, INSPECTION AND REPAIR OF MAIN GEAR DOOR ASSEMBLY.

- a. Clean the door and retraction rod with a suitable cleaning solvent.
- b. Inspect the door for cracks or damage, loose or damaged hinges and brackets.
- c. Inspect the door retraction rod and end bearing for damage and corrosion.
- d. Repairs to a door may be replacement of hinge, repair of fiberglass and painting.

7-30. INSTALLATION OF MAIN GEAR DOOR ASSEMBLY.

- a. Install the door by positioning the hinge halves of the door and wing, and inserting the hinge pin. It is recommended a new pin be used. Bend the end of the pin to secure in place.
- b. Install the door retraction rod by positioning the rod at its attachment points at the door and strut housing. At the door attachment, thin washers are inserted at each side of the rod end bearing and it is secured with bolt, washer and nut. At the strut housing, place washers between rod end bearing and housing not to exceed .12 of an inch to obtain proper clearance and secure with bolt. Safety bolt with MS20995C41 wire.
- c. Check that the all around clearance between the door and the wing skin is not less than .032 of an inch.

7-31. ADJUSTMENT OF MAIN GEAR DOOR ASSEMBLY.

- a. Place the airplane on jacks. (Refer to Jacking, Section II.)
- b. Ascertain that the main gear is properly adjusted for gear up as given in Paragraph 7-26.
- c. Adjust the retraction rod end at the door so that the door will pull up tightly when the gear is full up. Over tightening may result in door buckling; however, if the door is too loose, it will gap in flight.
- d. Check all rod ends for adequate thread engagement, for safety and tightness of jam nuts.
- e. Remove the airplane from jacks.

7-32. LANDING GEAR LIMIT SWITCHES.

NOTE

All adjustments of the limit switches should be made with the airplane on jacks. (Refer to Jacking, Section II.)

NOTE

Do not bend the actuator springs mounted on the limit switches.

7-33. ADJUSTMENT OF NOSE GEAR UP LIMIT SWITCH. The gear up limit switch is mounted on a bracket on the engine mount above the point where the right side of the upper drag link attaches to the engine mount.

- a. To facilitate adjustment of the limit switch, disconnect the gear doors or remove the bottom cowl, as desired.
- b. Retract the landing gear by turning the master switch on, raising the emergency gear extension lever and moving the gear selector handle to the up position. Retain the emergency extension lever in the up position and turn the master switch off.
- c. Block the nose gear in the up position and then slowly release the emergency extension lever. This will relieve hydraulic pressure and the main gears will drop.
- d. Place a .027 of an inch spacer on the oleo strut housing between the housing and the crossover tube where the steering arm attaches. Push the gear up tight and block.
- e. Loosen the attachment screws of the switch and rotate the switch toward the actuator tang until it is heard to actuate. Retighten the attachment screws of the switch.
- f. Manually move the gear up and down only as far as necessary to ascertain that the switch actuates at the correct position. Remove the block from under the gear and allow it to slowly extend.
- g. Retract the gear electrically and ascertain that the red gear unsafe light will go out when the gear has retracted and the pump has shut off.

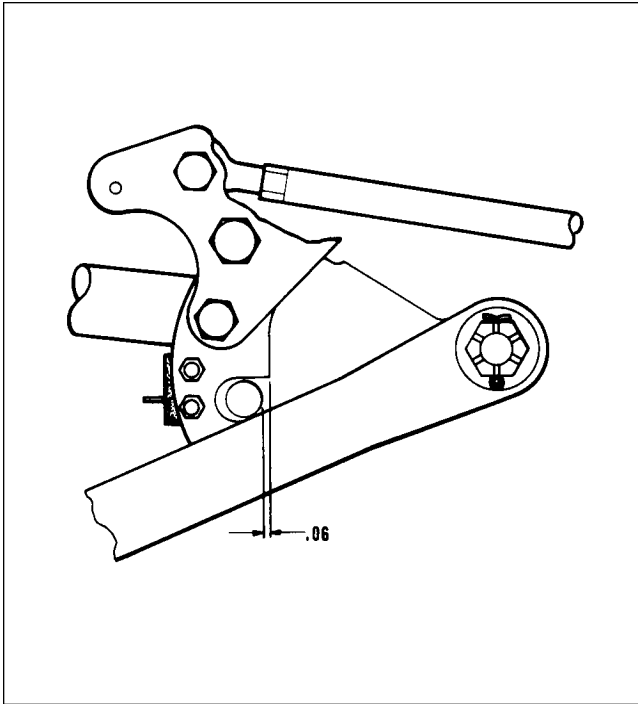

Figure 7-12. Adjustment of Nose Gear Down Limit Switch

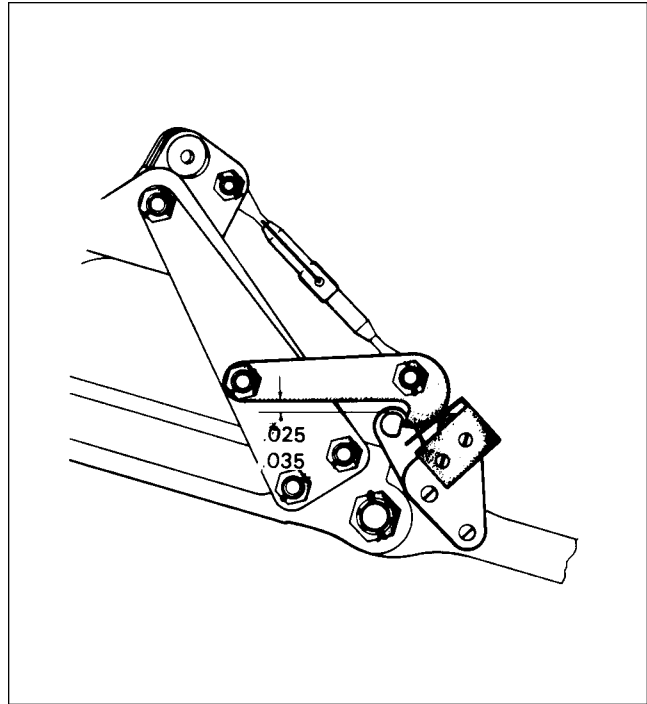

Figure 7-13. Adjustment of Main Gear Down Limit Switch

7-34. ADJUSTMENT OF NOSE GEAR DOWN LIMIT SWITCH. The gear down limit switch is mounted on the horizontal support tube of the engine mount that runs between the tight attachment points of the gear housing and upper drag link.

- a. Ascertain that the gear is down and locked.
- b. The down limit switch should actuate only after the leading edge of the downlock hook, when moving to the locked position, has passed the downlock roller by .06 of an inch. (Refer to Figure 7-12.) Position the hook at this location in relation to the roller by moving the actuator piston manually toward the up position. The downlock spring may be disconnected, if desired.
- c. Loosen the attachment screws of the actuator located on the downlock hook and move it toward the switch until it is heard to actuate. Retighten the actuator screws.
- d. Manually move the hook from the locked to the unlocked position and ascertain that the switch actuates at the correct location of the hook.
- e. Retract and extend the gear electrically by turning the master switch on, raising the emergency gear extension lever and moving the gear selector handle to the up position. As the gear begins to retract, the green light below the selector should go out and the red gear unsafe light at the top of the instrument panel should come on.

7-35. ADJUSTMENT OF MAIN GEAR UP LIMIT SWITCH. A gear up limit switch is located in each wheel well above the door hinge. There is no adjustment of these switches other than check that the gear, when retracting, will actuate the switch within .88 of an inch of full up. Switch operation turns the red gear unsafe light out.

7-36. ADJUSTMENT OF MAIN GEAR DOWN LIMIT SWITCH. A gear down limit switch is mounted on a bracket which is attached to the lower drag link of each main gear. The switch should be adjusted to allow it to actuate thus turning on the green indicator light within the cockpit when the downlock hook has entered the locked position and is within .025 to .035 of an inch of contacting the downlock pin. (Refer to Figure 7-13.)

Adjustment of the switch may be as follows:

- a. Ascertain that the main gear downlock is properly adjusted as described in Paragraph 7-26.
- b. Raise the airplane on jacks. (Refer to Jacking, Section II.)
- c. Ascertain that the landing gear is down and pressure is relieved from the hydraulic system. To relieve pressure, hold down the emergency extender lever.
- d. Raise the downlock hook assembly and place a .030 of an inch feeler gauge between the horizontal surface of the hook that is next to the switch. (the surface that contacts the downlock pin) and the rounded surface of the pin. Lower the hook and allow it to rest on the feeler gauge.
- e. Loosen the attaching screws of the switch and, while pushing up on the center of the link assembly, rotate the switch toward the hook until it is head to actuate. Retighten the attaching screws of the switch.
- f. Manually move the hook assembly up from the pin until the hook nearly disengages from the pin. Then, with pressure against the bottom of the link assembly, move back to ascertain that the switch actuates within .025 to .035 of an inch of full lock.
- g. Retract and extend the gear by turning the master switch on, raising the emergency gear extension lever and moving the gear selector handle to the up position. As the gear begins to retract, the green light below the selector should go out and the red gear unsafe light at the top of the instrument panel should come on.

7-37. ADJUSTMENT OF LANDING GEAR SAFETY SWITCH (SQUAT SWITCH). The landing gear safety switch, located on the left main gear housing is adjusted so that the switch is actuated within the last quarter of an inch of gear extension.

- a. Compress the strut until 7.875 inches is obtained between the top of the gear fork and the bottom of the gear housing. Hold the gear at this measurement.
- b. Adjust the switch down until it actuates at this point. Secure the switch.
- c. Extend and then compress the strut to ascertain that the switch will actuate within the last quarter of an inch of oleo extension.

WARNING

Applicable to airplanes that are in compliance with Piper Service Bulletin 886A, Part II.

7-38. ADJUSTMENT OF GEAR BACK-UP EXTENDER ACTUATOR SWITCH. The back-up gear extender actuator switch is mounted on the extender unit located under the bottom section of the rear seat. Inasmuch as the switch is a component of the back-up extender, instructions for the adjustment of the switch will be found with the adjustment instructions for the extender as found in Section VI.

7-39. LANDING GEAR WARNING SWITCHES (THROTTLE SWITCHES).

7-40. LANDING GEAR UP/POWER REDUCED WARNING SWITCH. The gear up/power reduced warning switch is within the control quadrant below the throttle control lever. (Refer to Figure 7-15.) This switch will actuate the warning horn and red light simultaneously when the landing gear is not down and locked and the throttle is reduced to the below 14 inches of manifold pressure.

7-40a. LANDING GEAR UP/FLAP TORQUE TUBE CAM WARNING SWITCH. (All aircraft with back-up gear extender disabled, or PA-28R-201/20IT, S/N's 2837001 & 2803001 and up.) Any flap selection in excess of 10 degrees, or beyond the first notch, will activate the warning horn and red light simultaneously. Adjust the switch assembly so the roller remains within the cam slot and the switch remains open and when in excess of 10 degrees, the roller exits the slot and allows the switch to close giving the landing gear up warning indication (Refer to Figure 7- 14.)

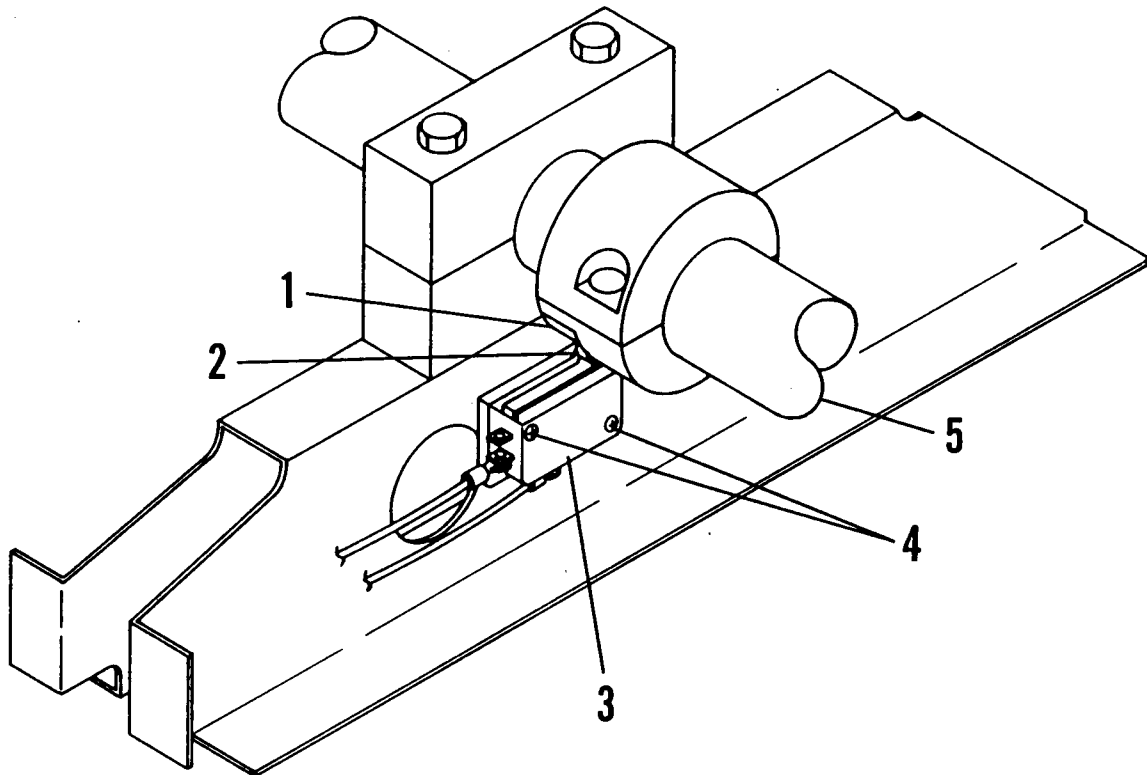

- 1. CAM ASSEMBLY
- 2. SWITCH CONTACT ROLLER
- 3. SWITCH
- 4. MOUNTING
- 5. FLAP TORQUE TUBE

Figure 7-14. Flap Torque Tube Cam Gear Warning Switch Installation

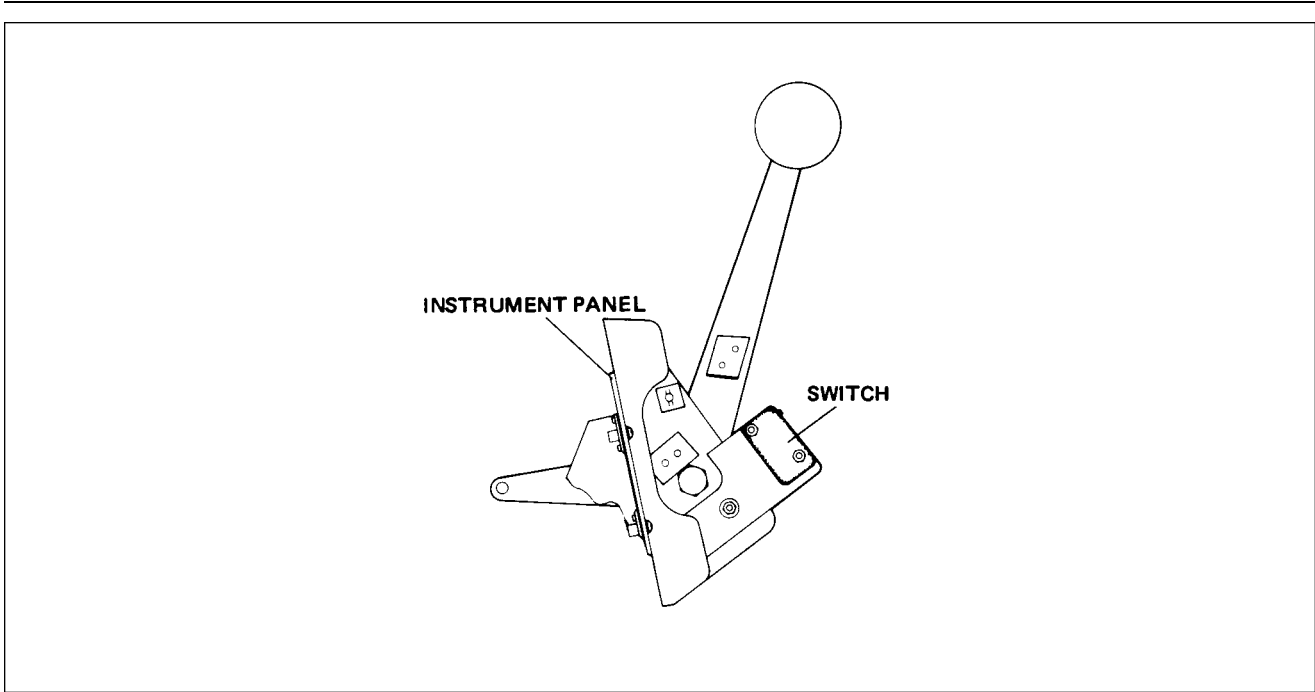

Figure 7-15. Throttle Warning Switches

7-41. REMOVAL OF LANDING GEAR UP/POWER REDUCED WARNING SWITCH.

- a. Loosen the quadrant cover by removing the cover attaching screws from each side and at the bottom of the cover.
- b. Pull the cover aft enough to remove the screws that secure the reinforcing clip to the top underside of the cover. Remove the cover.
- c. Remove the switch from its mounting bracket by removing the switch attaching screws.
- d. Disconnect the electrical leads from the switch.

7-42. INSTALLATION OF LANDING GEAR UP/POWER REDUCED WARNING SWITCH.

- a. Connect the electrical leads to the switch.
- b. Position the switch with actuator follower against its mounting bracket and secure with screws.
- c. The switch may be adjusted at this time per instructions in Paragraph 7-43.
- d. With the control levers aft, slide the quadrant cover into position around the controls far enough to allow the cover reinforcement clip to be installed to the top underside of the cover and secure with screws.
- e. Install the cover and secure with screws.

7-43. ADJUSTMENT OF LANDING GEAR UP/POWER REDUCED WARNING SWITCH.

- a. Remove the control quadrant cover as given in Paragraph 7-41.
- b. Flight test the airplane and at a safe altitude, establish a normal descent with gear up and the propeller control at a desired low pitch setting.
- c. Retard the throttle to a manifold pressure of approximately 14 inches. This setting should be an airspeed above 110 KIAS.
- d. In some manner, mark the throttle lever in relation to its position next to the mounting bracket.
- e. With the airplane on the ground and the throttle positioned to the mark, loosen the screws that secure the switch and rotate it toward the throttle until it is heard to actuate. Retighten the switch attachment screws.

- f. Advance and retard the throttle to ascertain that the switch actuates at the desired throttle lever setting. The airplane may also be down to ascertain that the horn and light will actuate when the throttle is reduced below approximately 14 inches of manifold pressure with gear up.
- g. Reinstall the quadrant cover as given in Paragraph 7-42.

7-44. WHEELS.

7-45. REMOVAL AND DISASSEMBLY OF NOSE WHEEL. (Refer to Figure 7-16.)

- a. Jack the airplane enough to raise the nose wheel clear of the ground. (Refer to Jacking, Section II.)
- b. To remove the nose wheel, first remove the cotter pin and washer that secures the safety clevis pin of the wheel nut. Next remove the clevis pin, wheel nut and then slide the wheel from the axle.
- c. The wheel halves (7 and 10) may be separated by first deflating the tire. With the tire sufficiently deflated, remove the wheel through bolts (18). Pull the wheel halves from the tire by removing the wheel half opposite the valve stem first and then the other half.
- d. The wheel bearing assemblies may be removed from each wheel half by first removing the snap rings (1 or 16) that secure the grease seal retainers, and then the retainers, grease seals (4 or 13) and bearing cones (6 or 12). The bearing cups (5 or 11) should be removed by tapping out evenly from the inside.

7-46. INSPECTION OF NOSE WHEEL ASSEMBLY.

- a. Visually check all parts for cracks, distortion, defects and excess wear.
- b. Check tie bolts for looseness or failure.
- c. Check internal diameter of felt grease seals. Replace the felt grease seal if surface is hard or gritty.
- d. Check tire for cuts, internal bruises and deterioration.
- e. Check bearing cones and cups for wear and pitting and relubricate.
- f. Replace any wheel casting having visible cracks.

7-47. ASSEMBLY AND INSTALLATION OF NOSE WHEEL. (Refer to Figure 7-16.)

- a. Ascertain that the bearing cup (5 or 11) for each wheel half (7 and 10) is properly installed. Install the tire with tube on the wheel half with the valve stem hole and then join the two wheel halves. Install the through bolts (18) with the washer (9 and 17) and nuts (8) to the valve stem side.

NOTE

On aircraft models which use the Cleveland wheel assembly, torque nuts to 90 inch-pounds. Those aircraft models which use the McCauley wheel assembly, torque nuts to 140-150 inch-pounds.

NOTE

On McCauley nose wheel assemblies only, bushing (19) is required to prevent tube movement.

- b. Position the tire and tube so the index mark on the tire is aligned with the index mark on the tube. This will maintain proper balance of the wheel. Inflate the tire to the specified pressure as given in Table II-I of Section II.
- c. Lubricate the bearing cones (6 and 12) and install the cones, grease seals (4 or 13), felt rings (3 or 14) and seal retainer rings (2 or 15). Secure with snap rings (1 or 16).
- d. Slide the wheel on the axle and secure with retainer nut. Tighten nut to allow no side play, yet allow the wheel to rotate freely. Safety the nut with clevis pin and secure pin with washer and cotter pin.

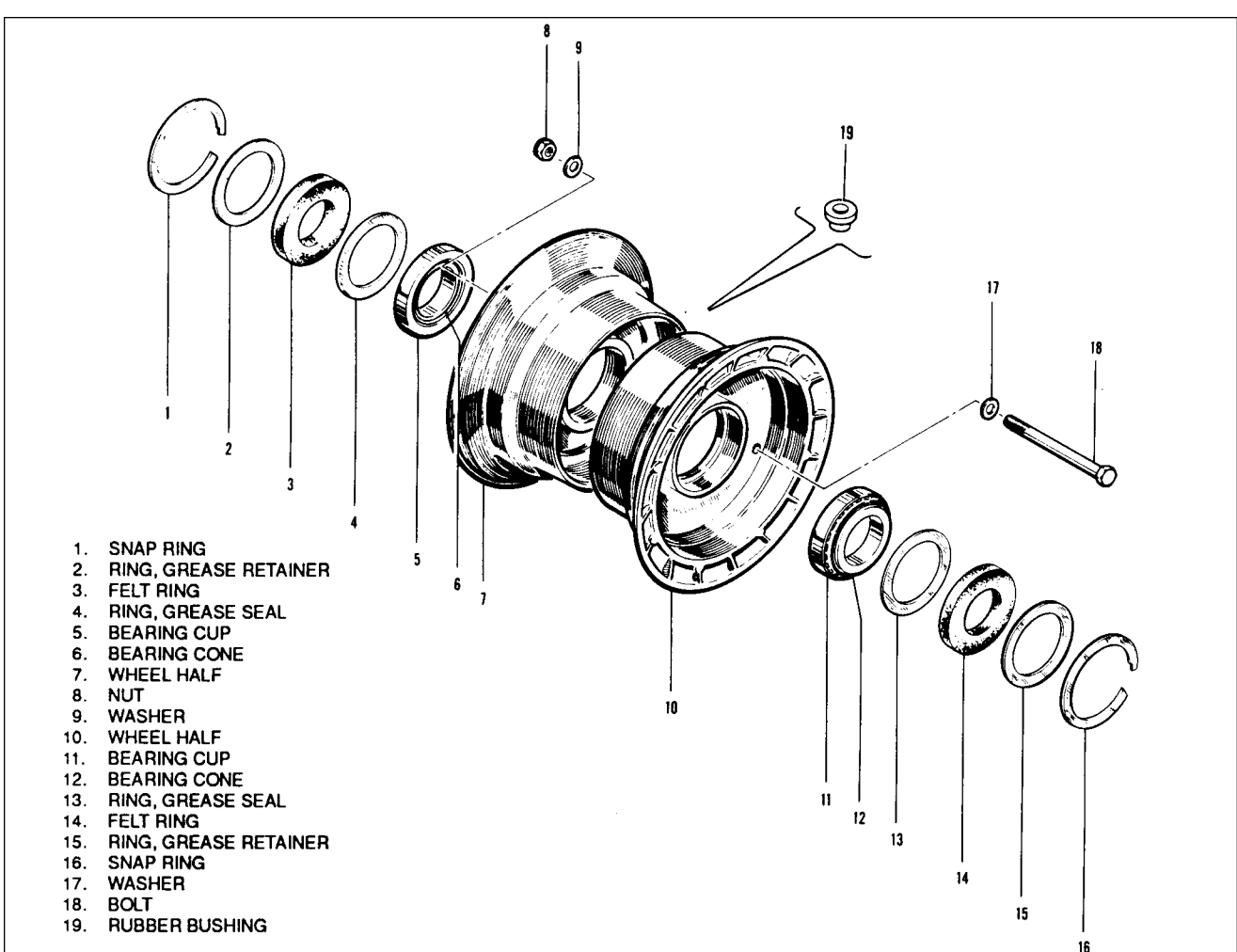

Figure 7-16. Nose Wheel Assembly

7-48. REMOVAL AND DISASSEMBLY OF MAIN WHEEL. (Refer to Figure 7-17.)

- a. Place the airplane on jacks. (Refer to Jacking, Section II.)
- b. To remove the main wheel, remove the four cap bolts that join the brake cylinder housing and the lining back plate assemblies. Remove the back plate from between brake disc and wheel.
- c. Remove the dust cover and the cotter pin that safeties the wheel nut, remove the wheel nut and slide the wheel from the axle.
- d. The wheel halves (7 and 8) may be separated by first deflating the tire. With the tire sufficiently deflated, remove the wheel through bolts (16). Pull the wheel halves from the tire by removing the inner half (8) from the tire first and then the outer half. The brake disc (15) may be removed at this time.
- e. The wheel bearing assemblies may be removed from each wheel half by first removing the snap rings (1 or 14) that secure the grease seal retainers (2 or 13) and then the retainers, grease seals (4 or 11) and bearing cones (6 or 10). The bearing cups (5 or 9) should not be removed only for replacement and may be removed by tapping out evenly from the inside.

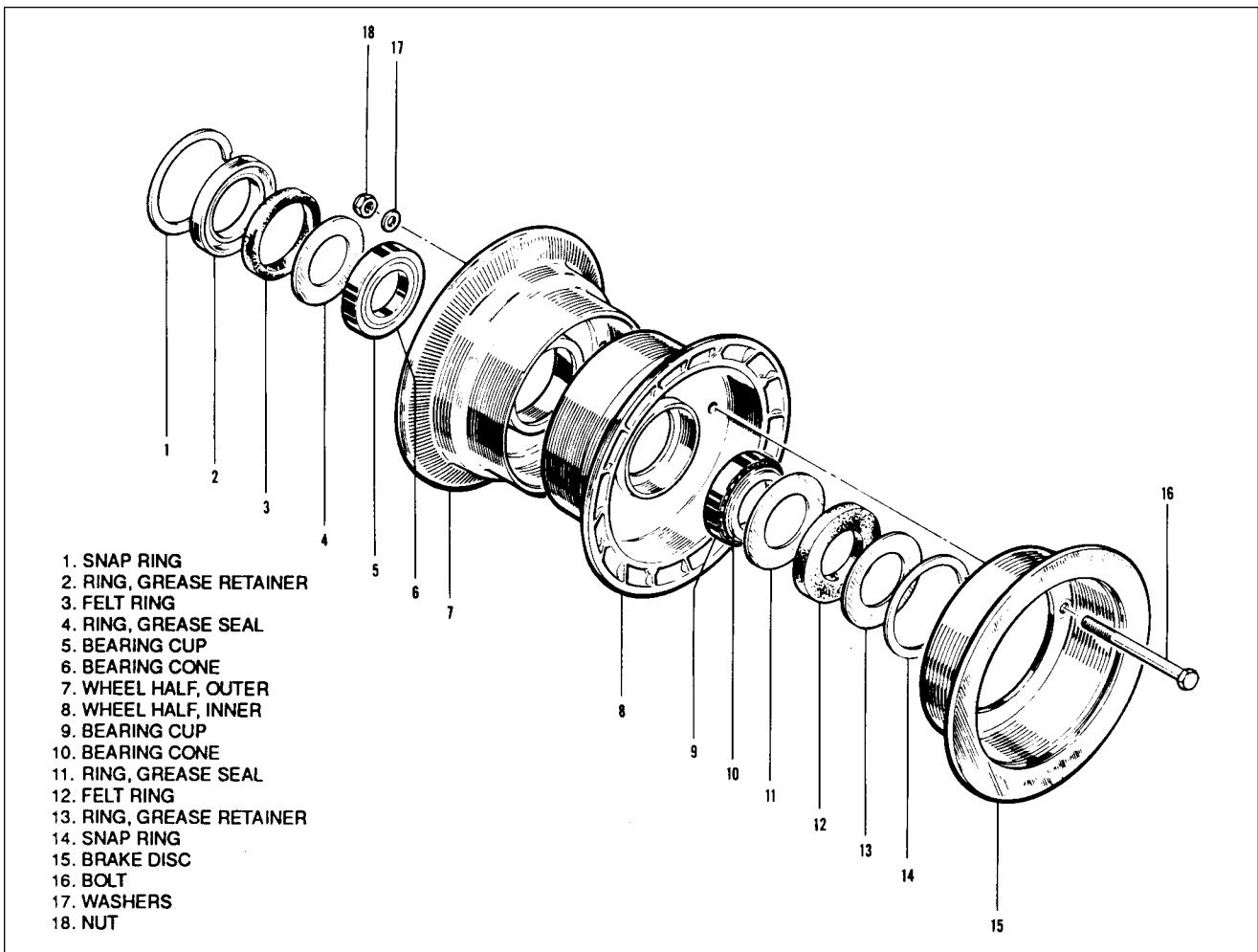

Figure 7-17. Main Wheel Assembly

7-49. INSPECTION OF MAIN WHEEL ASSEMBLY. The inspection of the main wheel is the same as that given for the nose wheel, Paragraph 7-46.

7-50. ASSEMBLY AND INSTALLATION OF MAIN WHEEL. (Refer to Figure 7- 17.)

- a. Ascertain that the bearing cup (5 or 9) for each wheel is properly installed. Install the tire with tube on the outer wheel half (7) and then join the two wheel halves. Position the brake disc (15) in the inner wheel half and install the through bolts with the nuts on the valve stem side. Torque wheel nuts to 150 inch pounds and inflate tire.
- b. Lubricate the bearing cones (6 or 10) and install the cones, grease seals (4 or 11), seal retainer rings (2 or 13) and felt rings (3 or 12). Secure with snap rings (1 or 14).
- c. Slide the wheel on the axle and secure with retainer nut. Tighten the nut to allow no side play, yet allow the wheel to rotate freely. Safety the nut with a cotter pin and install dust cover.
- d. Position the brake lining back plates between the wheel and brake disc and the brake cylinder on the torque plate. Insert the spacer blocks between the back plates and cylinders and install the four bolts to secure the assembly. If the brake line was disconnected, reconnect the line and bleed the brakes.

1. TORQUE PLATE ASSY.
2. ANCHOR BOLT
3. BRAKE LINING
4. RIVET
5. BACK PLATE ASSY.
6. BOLT
7. O-RING
8. PISTON ASSY.
9. PRESSURE PLATE ASSY.
10. BRAKE DISCS

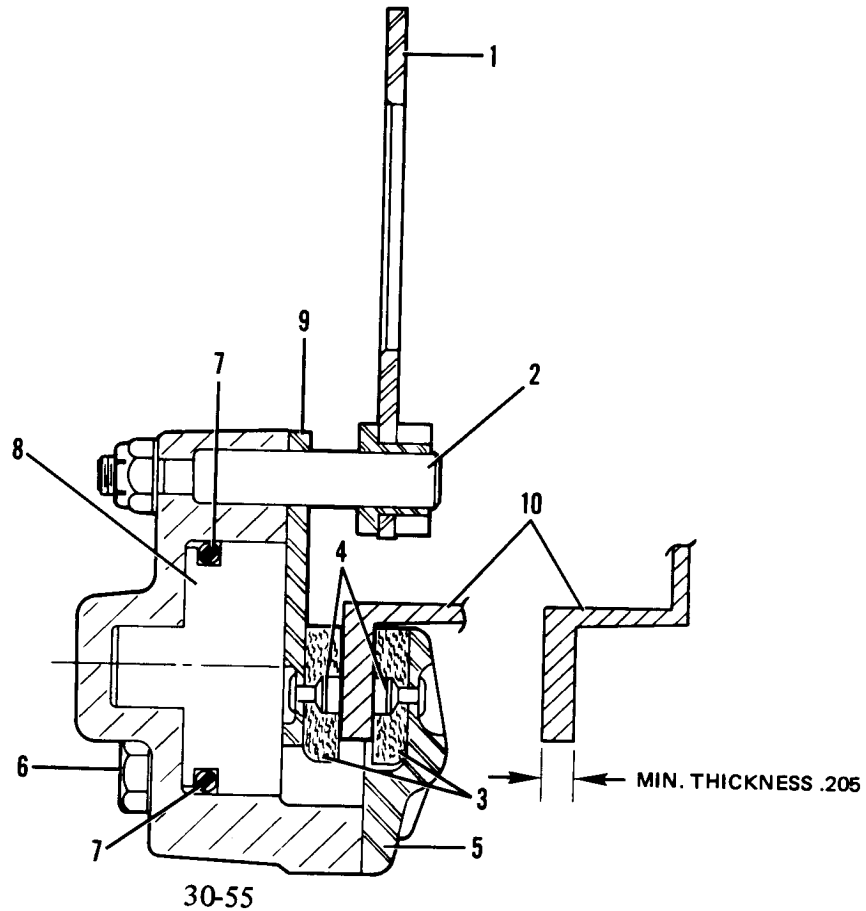

Figure 7-18. Wheel Brake Assembly

7-51. BRAKE SYSTEM.

7-52. WHEEL BRAKE ASSEMBLY.

7-53. BRAKE ADJUSTMENT AND LINING TOLERANCE. No adjustment of the brake lining clearance is necessary as they are self adjusting. Inspection of the lining is necessary and it may be inspected visually while installed on the airplane. The linings are of the riveted type and should be replaced if the thickness of any one segment becomes worn below .100 of an inch or unevenly worn.

7-54. REMOVAL AND DISASSEMBLY OF WHEEL BRAKE ASSEMBLY. (Refer to Figure 7-18.)

- a. To remove the brake assembly, first disconnect the brake line from the brake cylinder at the tube fitting.
- b. Remove the cap bolts that join the brake cylinder housing and the lining back plate assembly. Remove the back plate from between the brake disc and wheel.
- c. Slide the brake cylinder housing from the torque plate.
- d. Remove the pressure plate by sliding it off the anchor bolts of the housing.

- e. The piston(s) may be removed by injecting low air pressure in the cylinder fluid inlet and forcing the piston from the housing.
- f. Check anchor bolt for wear.
- g. Remove anchor bolt by the following procedure:
 - 1. Position cylinder assembly on a holding fixture. (Refer to Figure 7-19.)
 - 2. Use a suitable arbor press to remove the anchor bolt from the cylinder head.

7-55. CLEANING, INSPECTION AND REPAIR OF WHEEL BRAKE ASSEMBLY.

- a. Clean the assembly with a suitable solvent and dry thoroughly.
- b. Check the wall of the cylinder housing and piston for scratches, burrs, corrosion, etc, that may damage O-rings.
- c. Check the general condition of the brake bleeder screw and lines.
- d. Check the brake disc for wear, grooves, scratches, or pits. Wear of the disc should not be less than 0.205 of an inch at its thinnest point. A single groove or isolated grooves up to 0.031 of an inch deep would not necessitate replacement, but a grooving of the entire surface would reduce lining life and should be replaced. Should it be necessary to remove the wheel disc, refer to paragraph 7-48.
- e. Lining may be removed from the backing plates by drilling or punching out the old rivets and installing a new set using the proper rivets and a rivet set that will properly stake the lining and form a correct flair of the rivet.

7-56. ASSEMBLY AND INSTALLATION OF WHEEL BRAKE ASSEMBLY. (Refer to Figure 7- 18.)

- a. Lubricate the piston O-ring(s) with fluid MIL-H-5606 and install on piston(s). Slide the piston in cylinder housing until flush with surface of housing.
- b. Slide the lining pressure plate onto the anchor bolts of the housing.
- c. Slide the cylinder housing assembly on the torque plate of the gear.
- d. Position the lining back plate between the wheel and brake disc. Install the bolts and torque to 40 inch pounds to secure the assembly.
- e. Connect the brake line to the brake cylinder housing.
- f. Bleed the brake system as described in paragraph 7-69.

NOTE

In order to obtain optimum service life from newly installed brake linings, they must be properly conditioned. To condition the brake linings, perform a minimum of six light pedal effort braking applications from 25 to 40 mph. Allow the brake discs to partially cool between stops.

7-57. BRAKE MASTER CYLINDER. (Hand Parking Brake.)

7-58. REMOVAL OF BRAKE MASTER CYLINDER. (Refer to Figure 7-21.)

- a. To remove the brake master cylinder (8), first disconnect the inlet supply line (13) from the fitting at the top of the cylinder and allow fluid to drain from the reservoir and line into a suitable container.
- b. Disconnect the pressure line from the fitting at the bottom of the cylinder and allow fluid to drain from the cylinder line.
- c. Disconnect the end of the cylinder rod from the brake handle (6) by removing the cotter pin that safeties the connecting clevis pin (12). Remove the clevis pin and spacer washers.
- d. Disconnect the base of the cylinder from its mounting bracket by removing the attachment bolt assembly (11).
- e. The handle assembly (6) may be removed by removing the attachment bolt assembly that secures the handle to its mounting bracket.

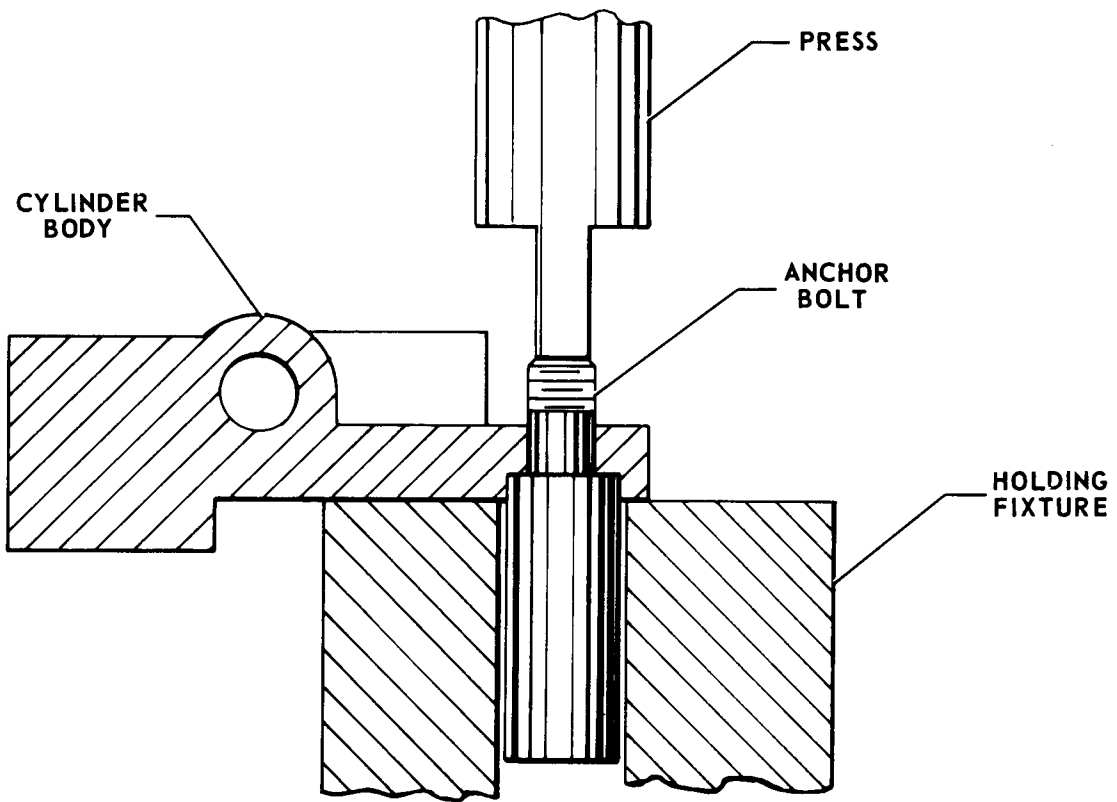

Figure 7-19. Removal of Anchor Bolt

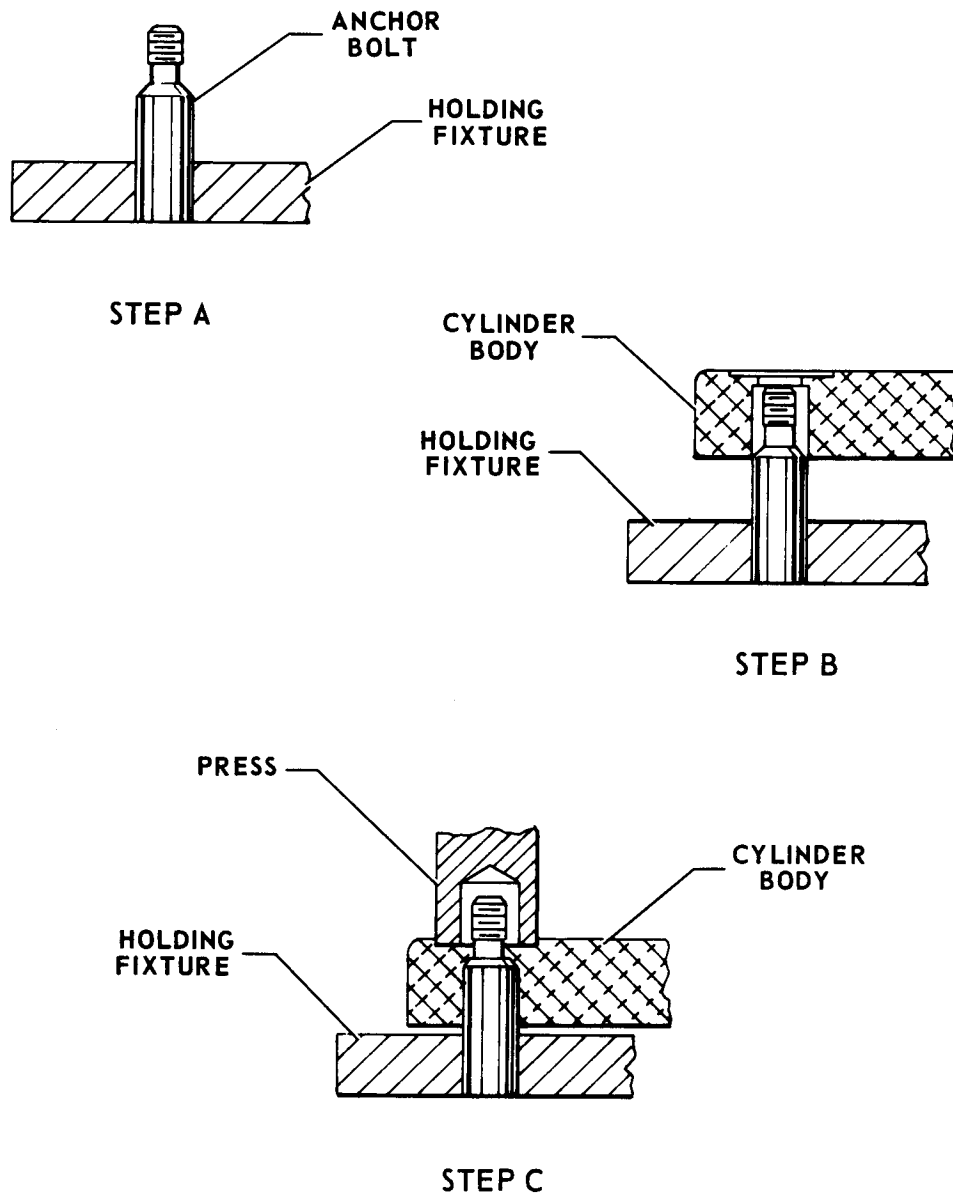

Figure 7-20. Installation of Anchor Bolt

7-59. DISASSEMBLY OF BRAKE MASTER CYLINDER. (Refer to Figure 7-22.)

- a. Remove the cylinder from its mounting bracket as per paragraph 7-58.
- b. To disassemble the cylinder, first remove the piston rod assembly by removing the snap ring (11) from the annular slot at the rod end of the cylinder. Draw the piston rod assembly from the cylinder.
- c. The piston rod assembly may be disassembled by first removing the small snap ring (2) securing the retainer bushing (3), spring (4), piston (6), seal (7), gland (9) and if desired, the large return spring.
- d. Remove the O-rings from the piston and gland.

7-60. CLEANING, INSPECTION AND REPAIR OF BRAKE MASTER CYLINDER.

- a. Clean the cylinder parts with a suitable solvent and dry thoroughly.
- b. Inspect the interior walls of the cylinder for scratches, burrs, corrosion, etc.
- c. Inspect the general condition of the fitting threads of the cylinder.
- d. Check the piston and valve for scratches, bum, corrosion, etc.
- e. Repairs to the cylinder are limited to polishing out small scratches, bum, etc and replacing valve washer seal and O-rings.

7-61. ASSEMBLY OF BRAKE MASTER CYLINDER. (Refer to Figure 7-22.)

NOTE

Use a small amount of hydraulic fluid (MIL-H-5606) on the O-ring and component parts to prevent damage and ease of handling during reassembly.

- a. Install new O-rings on the inside and outside of the packing gland (9) and on the outside of the piston (6). (When installing teflon O-ring (5) on piston, it is recommended that it be installed with the use of a cone placed against the piston. The cone may be constructed of plastic or metal with dimensions shown in Figure 17-22.)
- b. To assemble the piston rod assembly, install on the rod (12), in order, the roll pin (14), return spring retainer washer (15), return spring (13), packing gland (9) with O-rings, seal (10), piston (6) with O-ring, spring (4) and retainer bushing (3). Secure these pieces with the small ring (2) on the end of the rod.
- c. Insert the piston rod assembly in the cylinder (1) and secure packing gland with snap ring (11).
- d. Install the cylinder per paragraph 7-68.

7-62. INSTALLATION OF BRAKE MASTER CYLINDER. (Refer to Figure 7-21.)

- a. Install the brake handle assembly between its mounting bracket and secure with bolt, washers, nut and cotter pin. Washers should be placed on each side of the handle, between the bracket, and under the nut.
- b. Place the cylinder (8) between the mounting bracket and secure the base end with bolt, washers, nut and cotter pin. This too should have washers placed on each side of the cylinder and under the nut.
- c. Connect the rod end of the cylinder to the brake handle with a clevis pin and thin washers. Safety the clevis with a cotter pin.
- d. Connect the pressure line to the fitting at the bottom of the cylinder.
- e. Connect the inlet supply line (13) to the fitting at the top of the cylinder and secure with spring clamp.
- f. Bleed the brake system per paragraph 7-69.

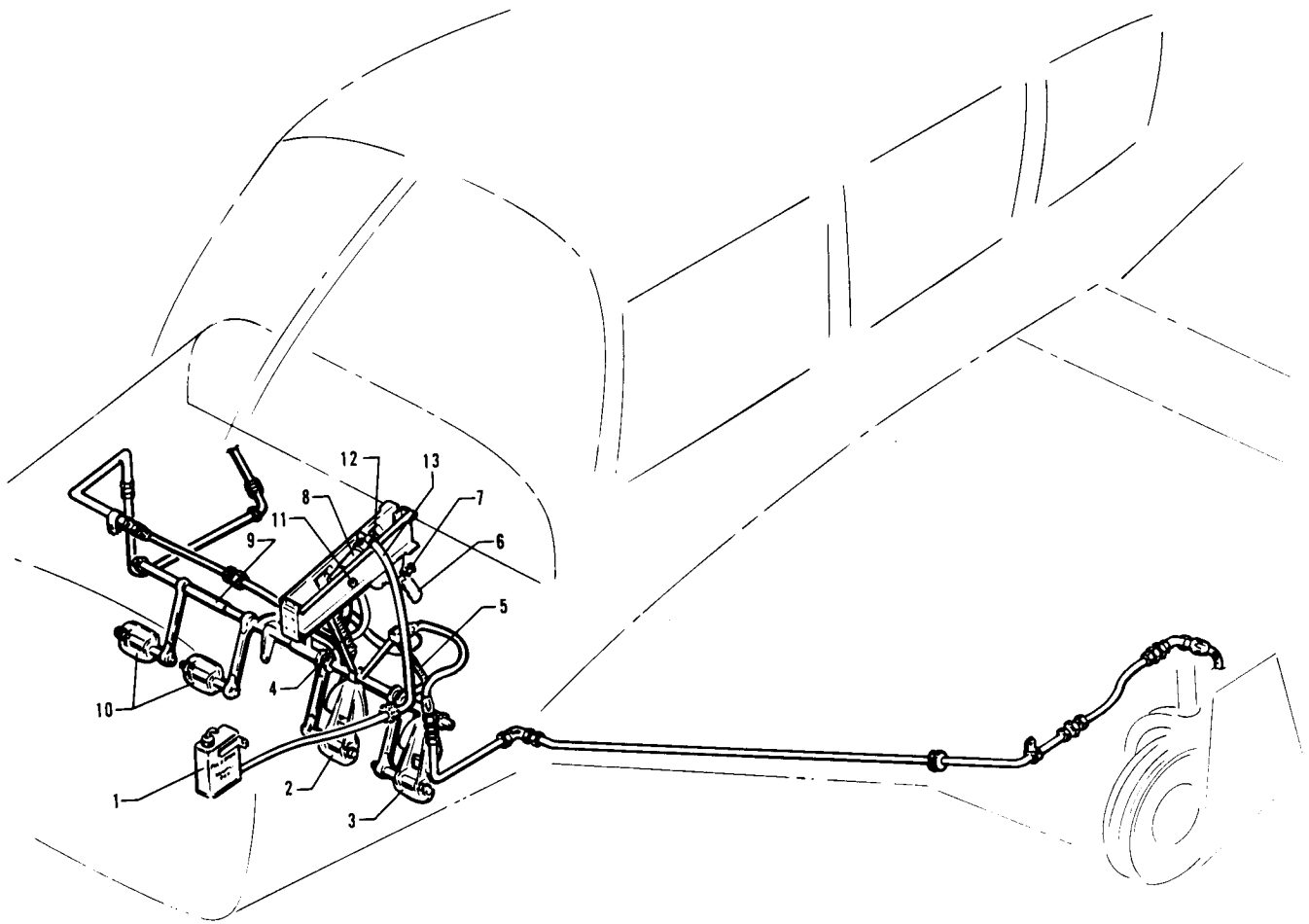

1. BRAKE RESERVOIR
2. RIGHT BRAKE AND RUDDER PEDAL
3. LEFT BRAKE AND RUDDER PEDAL
4. RIGHT BRAKE CYLINDER
5. LEFT BRAKE CYLINDER
6. BRAKE HANDLE
7. HANDLE RELEASE BUTTON
8. MASTER CYLINDER ASSEMBLY
9. TORQUE TUBE
10. RUDDER PEDAL PADS
11. BOLT ASSEMBLY
12. CLEVIS PIN
13. LINE, INLET

Figure 7-21. Brake System Installation

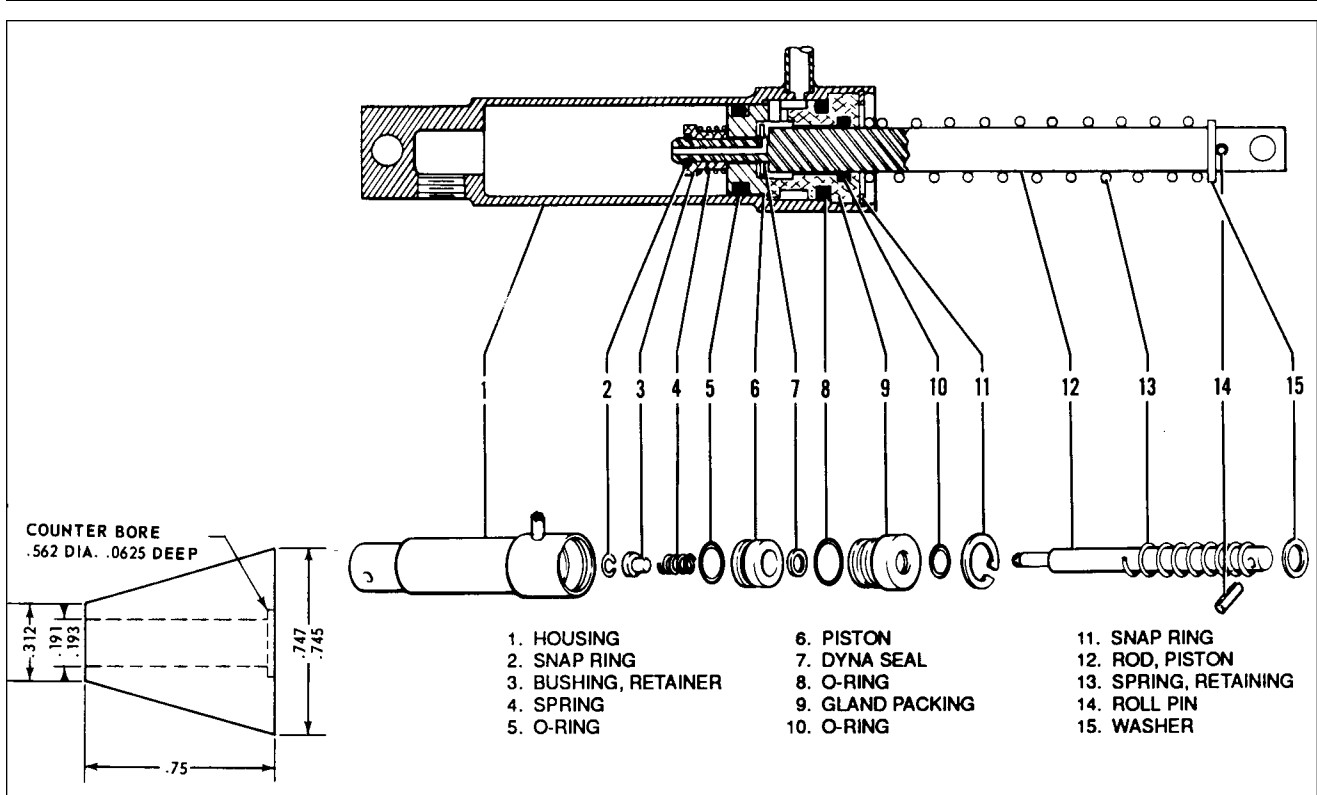

Figure 7-22. Brake Master Cylinder (Hand/Parking Brake)

7-63. BRAKE CYLINDER (TOE BRAKE)

7-64. REMOVAL OF BRAKE CYLINDER. (Refer to Figure 7-23.)

- a. Disconnect the upper and lower lines from the cylinder (14) to be removed and cap the lines to prevent fluid leakage or drain the fluid from the brake reservoir and master cylinder.
- b. Remove cotter pins and clevis pins (4 and 16) securing brake cylinder in position, then remove brake cylinder.

7-65. DISASSEMBLY OF BRAKE CYLINDER.

- a. Gar-Kenyon cylinder number 17000. (Refer to Figure 7-24.)
 1. Remove the cylinder from its mounting bracket per paragraph 7-64.
 2. To disassemble the cylinder, first remove the piston rod assembly by unscrewing the fitting (8) from the cylinder.
 3. The piston rod assembly may be disassembled by first removing the retaining ring (2) and securing the sleeve, and then the spring (4), piston (6), seal (7), fitting (8) and if desired, the large return spring (11).
 4. Remove the O-rings from the piston and fitting.
- b. Cleveland cylinder number 10-27. (Refer to Figure 7-25.)
 1. Remove the cylinder from its mounting bracket per paragraph 7-60.
 2. To disassemble the cylinder, first remove the piston rod assembly by removing the retaining ring (10) from the annular slot in the cylinder housing (1). Draw the piston rod assembly from the cylinder.
 3. The piston rod assembly may be disassembled by first removing the roll pin (15), spring (2), and then the piston assembly (3), seal (5) and packing gland (7), and if desired, the large return spring (11).
 4. Remove the O-rings from the piston and packing gland.

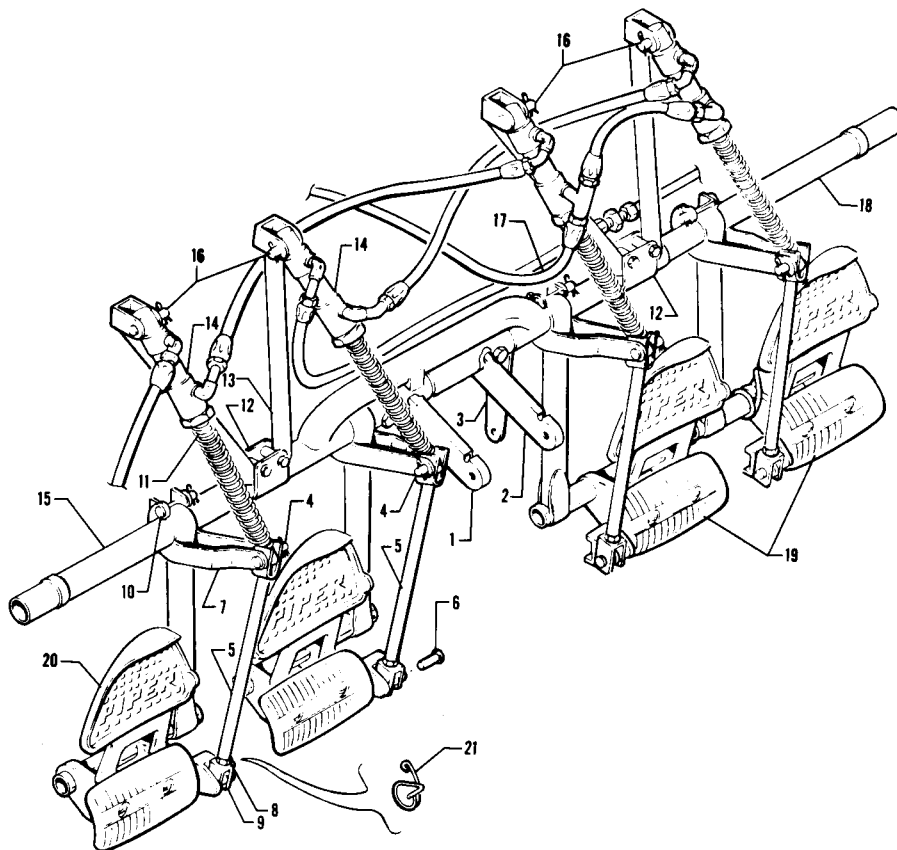

1. ARM, RUDDER CABLE ATTACHMENT
2. ARM, RUDDER CABLE ATTACHMENT
3. TRIM TRIM CONTROL ATTACHMENT
4. CLEVIS PIN, WASHER & COTTER PIN
5. CLEVIS ASSEMBLY
6. CLEVIS PIN
7. ARM, IDLER
8. JAM NUT
9. CLEVIS PIN, WASHER & COTTER PIN
10. CLEVIS PIN, WASHER & COTTER PIN
11. SPRING, RETURN
12. BRACKET
13. BRACE ASSEMBLY
14. CYLINDER ASSEMBLY, HYDRAULIC
15. TUBE ASSEMBLY, LEFT
16. CLEVIS PIN COTTER PIN
17. NOSE ASSEMBLY - FLEXIBLE
18. TUBE ASSEMBLY, RIGHT
19. PEDAL PADS
20. TOE BRAKE PEDAL
21. SPRING CLIP

Figure 7-23. Toe Brake Installation

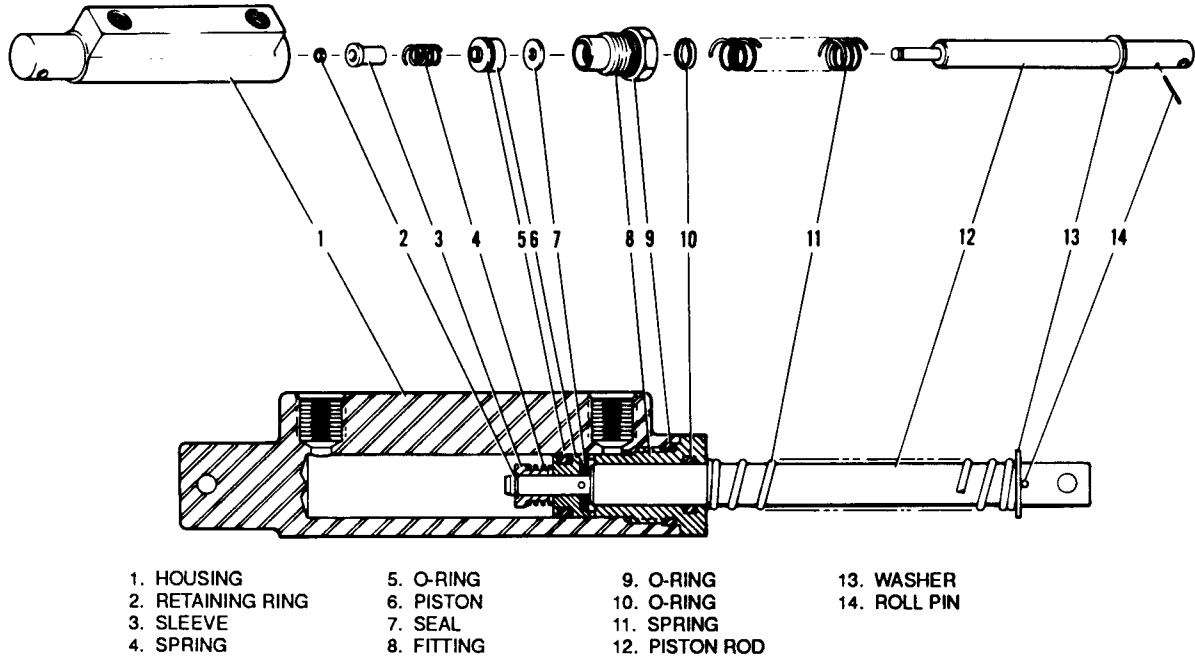

Figure 7-24. Brake Cylinder
(17000) (Toe Brake)

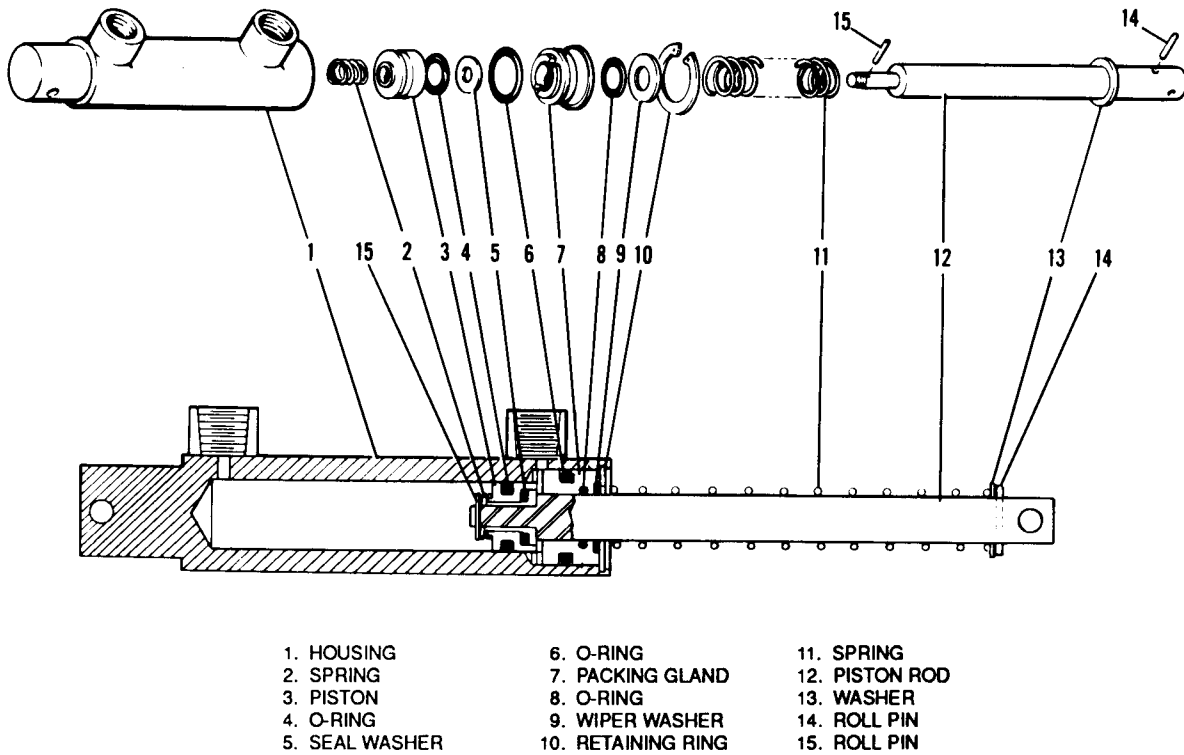

Figure 7-25. Brake Cylinder
(10-27) (Toe Brake)

7-66. CLEANING, INSPECTION AND REPAIR OF BRAKE CYLINDER

- a. Clean cylinder components with a suitable solvent and dry thoroughly.
- b. Inspect interior walls of cylinder for scratches, burrs, corrosion, etc.
- c. Inspect general condition of fitting threads.
- d. Inspect piston for scratches, burrs, corrosion, etc.
- e. Repairs to the cylinder are limited to polishing out small scratches and burrs and replacing seal and O-rings.

7-67. ASSEMBLY OF BRAKE CYLINDER. (Refer to Figures 7-24 and 7-25.)

NOTE

Rub a small amount of hydraulic fluid (MIL-H-5606) on all O-rings and component parts for ease of handling during reassembly and to prevent damage.

- a. Gar-Kenyon cylinder number 17000. (Refer to Figure 7-24.)
 1. Install new O-rings on the inside and outside of the fitting (8) and on the outside of the piston (6).
 2. To assemble the piston rod assembly, install on the rod (12), in order, the roll pin (14), return spring retainer washer (13), return spring (11), fitting (8) with O-rings, seal (7), piston (6) with O-ring, spring (4) and sleeve (3). Secure these pieces with the retaining ring (2) on the end of the rod.
 3. Insert the piston rod assembly in the cylinder (1) and secure fitting (8).
 4. Install the cylinder per paragraph 7-68.
- b. Cleveland cylinder number 10-27. (Refer to Figure 7-25.)
 1. Install new O-rings on the inside and outside of the packing gland (7) and on the outside of the piston (3).
 2. To assemble the piston rod assembly, install on the rod (12), in order, the roll pin (14), washer (13), spring (11), washer (9), packing gland (7) with O-rings, seal (5), piston assembly (3) with O-ring, spring (2), and roll pin (15).
 3. Insert the piston rod assembly in the cylinder (1) and secure with the retaining ring (10).
 4. Install the cylinder per paragraph 7-68.

7-68. INSTALLATION OF BRAKE CYLINDER. (Refer to Figure 7-24.)

- a. Position brake cylinder (14) at its mounting points and secure in position with clevis pin (4 and 16). Safety clevis pin with cotter pins.
- b. Connect brake lines to cylinder fittings. Bleed brakes as explained in paragraph 7-69 or 7-70.

7-69. BLEEDING BRAKES.

7-70. BRAKE BLEEDING PROCEDURE (Gravity). (Refer to Figure 7-26.)

- a. On both main landing gear wheel brake assemblies, attach a clear plastic hose to the brake bleeders and extend into container partially filled with hydraulic fluid, MIL-H-5606. The ends of this hose should be submerged in the fluid. Open both bleeders approximately one and one-half to two turns.
- b. Fill the brake reservoir on the firewall with hydraulic fluid, MIL-H-5606.
- c. Disconnect the toe brake cylinders from the pedal connection by removing clevis pin, washer and cotter pin.
- d. Invert toe brake cylinder to aid in releasing trapped air in the top of the cylinder.
- e. Check toe brake pedals in the cockpit to ensure pedals are pulled full aft
- f. Pull the hand brake handle, pumping the master cylinder very slowly approximately 25 times until fluid is observed passing through the clear plastic hoses at the wheel cylinder.

NOTE

Fluid level in the reservoir must be maintained to prevent air from entering in the line.

- g. Tighten both wheel bleeders.
- h. Pull hand brake until a firm handle is maintained.

7-71. BRAKE BLEEDING PROCEDURE (Pressure). (Refer to Figure 7-26.)

- a. Place a small clear plastic hose on the vent tube of the brake reservoir and place a second small clear plastic hose on the bleeder fitting on one main landing gear. Place the open ends of these tubes in a suitable container to collect the fluid overflow. Open the bleeder fitting one or two turns.
- b. On the other main gear, slide the hose of the pressure unit over the bleeder fitting then open the fitting one or two turns and pressure fill the brake system with MIL-H-5606 fluid.
- c. With fluid continually flowing through the brake system, SLOWLY and together actuate the hand brake and the toe brake pedal of the side being bled several times to purge the cylinders of air. On dual brake installations, both right and left pedals must be actuated.

NOTE

By watching the fluid pass through the plastic hose at the fluid reservoir and the bleeder fitting on the gear being bled, it can be determined whether any air is left in the system. If air bubbles are evident, filling of the system shall be continued until all the air is out of the system and a steady flow of fluid is obtained. Should the brake handle remain spongy, it may be necessary to disconnect the bottom of the toe brake cylinders (next to the pedal) and rotating the cylinder horizontally or even above horizontal and by use of the hand brake alone, purge the air from the system.

- d. Close the open bleeder fitting on the gear being bled. Close the open bleeder fitting to which the pressure hose is attached; then close the pressure unit and remove the hoses from the bleeder fittings. Check the brakes for proper pedal pressure. Replace the caps over the bleeder fittings.

NOTE

It may be necessary to remove any trapped air in the top of the wheel brake unit by applying pressure to the system with the brake hand lever and slowly opening the bleeder and release the hand lever.

- e. Repeat this procedure, if necessary, on the other gear.
- f. Drain excess fluid from the reservoir to fluid level line with a syringe.

7-72. BRAKE SYSTEM LEAK CHECK.

- a. Pull for a good firm hand brake and lock parking brake mechanism system to stand for approximately 10 minutes; then by gripping the parking brake handle, it should not be able to be pulled aft further than the original set. Should the handle be able to be pulled towards the panel and feel spongy, a leak is present at some point in the system. This leak may appear at any one of the connections throughout the system or internally in the master brake cylinder or wheel brake assemblies.

7-73. BLEEDING OF THE BRAKES AFTER A UNIT HAS BEEN CHANGED.

- a. Actuate the hand brake handle until some pressure builds up in the system. At this time, crack the attaching B nuts at any of the hose connections of the replaced unit. Most of the handle sponge feeling should be displaced by this action. Retighten B nuts.
- b. Actuate the master cylinder and the toe brake cylinder of the side unit which was changed and bleed fluid through the brake assembly on the wheel by pumping pressure and cracking bleeder until pressure drops.

CAUTION

Do not allow pressure to bleed off before closing bleeders, for this will allow air to enter the system. Repeat the pumping and bleeding approximately 10 or more times or until all the air is released from the system. During all bleeding, fluid level of the reservoir must be maintained.

INTENTIONALLY LEFT BLANK

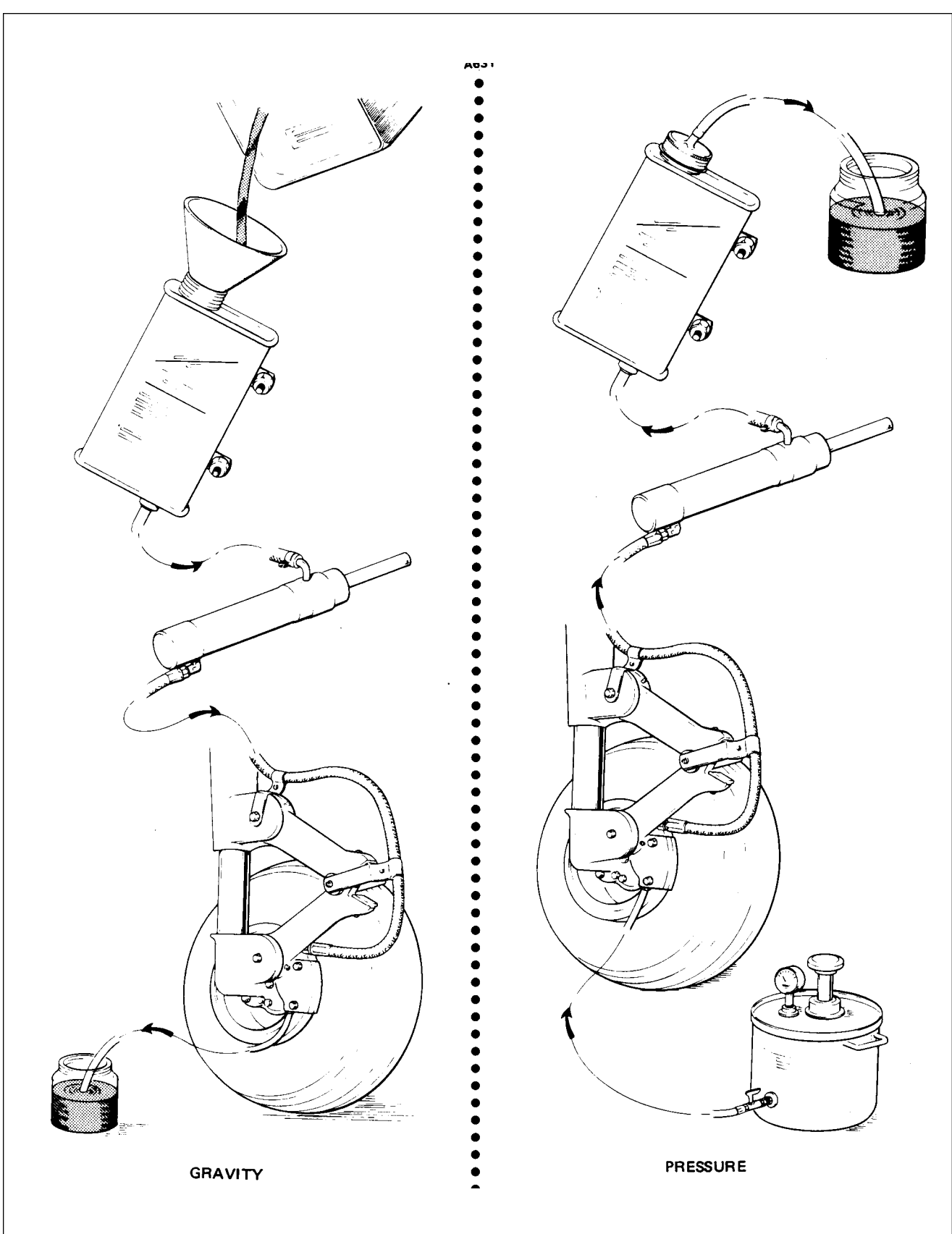

Figure 7-26. Bleeding Brakes

CHEROKEE ARROW III SERVICE MANUAL

TABLE VII-II. TROUBLESHOOTING CHART (LANDING GEAR)

Trouble	Cause	Remedy
Red gear unsafe light out while gear is in transit.	<p>Indicator lamp burned out.</p> <p>Indicator light ground incomplete.</p> <p>Indicator light circuit wire broken.</p> <p>Indicator light circuit breaker open.</p>	<p>Replace lamp.</p> <p>Check ground circuit.</p> <p>Check wiring.</p> <p>Reset circuit breaker and determine cause for open circuit breaker.</p>
Red gear unsafe light on though gear has retracted.	<p>One or more up limit switches failed.</p> <p>Nose gear up limit switch out of adjustment.</p> <p>Main gear not retracting far enough to actuate switch.</p>	<p>Isolate and replace switch.</p> <p>Check gear up adjustment and readjust up limit switch.</p> <p>Check gear up adjustment.</p>
Red gear unsafe light on though gear is down and locked.	<p>One or more down limit switches failed.</p> <p>Nose gear down limit switch out of adjustment.</p> <p>Main gear down limit switch out of adjustment.</p>	<p>Isolate and replace switch.</p> <p>Readjust down limit switch.</p> <p>Readjust down limit switch.</p>
<p>NOTE</p> <p><i>The out of adjustment or failed switch may be determined by noting which down light is not lit.</i></p>		

CHEROKEE ARROW III SERVICE MANUAL

TABLE VII-II. TROUBLESHOOTING CHART (LANDING GEAR) (cont)

Trouble	Cause	Remedy
<p>Red gear unsafe light operates on and off after gear has retracted.</p>	<p>Light circuit wire loose.</p> <p>Hydraulic system losing pressure.</p> <p>Gear up switch out of adjustment.</p>	<p>Check wiring.</p> <p>Refer to Hydraulic System, Section VI.</p> <p>Check gear up adjustment and then switch adjustment.</p>
<p>Red gear unsafe light out and one green gear down light out though gear is down and locked.</p> <p>NOTE: Ensure that navigation lights are off (daytime).</p>	<p>Lamp burned out.</p> <p>Gear down limit switch failed.</p> <p>Light circuit wire broken.</p>	<p>Replace lamp.</p> <p>Replace switch.</p> <p>Check wiring.</p>
<p>Red gear unsafe light and all green lights out.</p> <p>NOTE: Ensure that navigation lights are off (daytime).</p>	<p>Indicator lights circuit breaker open.</p> <p>Light circuit wire broken.</p>	<p>Reset circuit breaker and determine cause for open circuit breaker.</p> <p>Check wiring.</p>
<p>Red gear unsafe light and horn fail to operate when throttle is near closed and landing gear is retracted.</p>	<p>Landing gear selector circuit breaker open.</p>	<p>Reset circuit breaker and determine cause for open circuit breaker.</p>
AIRCRAFT WITHOUT BACKUP LANDING GEAR SYSTEMS		
<p>Warning horn inoperative</p>	<p>Loose or broken wire</p>	<p>Secure or repair wire.</p>
<p>Warning horn inoperative when flaps are selected beyond 10°.</p>	<p>Faulty switch Switch out of adjustment</p>	<p>Replace switch.</p> <p>Adjust switch.</p>

CHEROKEE ARROW III SERVICE MANUAL

TABLE VII-II. TROUBLESHOOTING CHART (LANDING GEAR) (cont)

Trouble	Cause	Remedy
Red gear unsafe light and horn fail to operate when throttle is near closed and landing gear is retracted (cont).	Micro switch at throttle	Adjust micro switch. out of adjustment.
	Micro switch at throttle	Replace switch. failed.
	Warning horn and light circuit wire broken.	Check wiring.
	Diode in circuit between throttle switch and light/horn open.	Replace diode. NOTE: When replacing diode, connect banded end (cathode) to terminal ends of wires G2S and G2U.
Green gear down lights dim though position light switch is off and gear is down and locked.	Failed instrument panel light control switch. (Lights grounding through dimming resistor instead of instrument panel light control.)	Replace switch.
Green gear down light fails to go out with gear in transit or retracted.	Gear down limit switch failed.	Replace switch.
Green gear down lights will go out and not dim when position light switch is turned on though gear is down and locked.	Green light ground dimming resistor open.	Replace resistor.

CHEROKEE ARROW III SERVICE MANUAL

TABLE VII-II. TROUBLESHOOTING CHART (LANDING GEAR) (cont)

Trouble	Cause	Remedy
Green gear down lights blink momentarily before the down lock is engaged on roller.	Micro switch out of adjustment.	Adjust micro switch.
Nose landing gear shimmies during fast taxi, takeoff, or landing.	Internal wear in shimmy dampener Shimmy dampener or bracket loose at mounting. Tire out of balance. Worn or loose wheel bearings. Worn torque link bolts and/or bushings.	Replace shimmy dampener. Replace necessary parts and bolts. Check balance and replace tire if necessary. Replace and/or adjust wheel bearings. Replace bolts and/or bushings.
Excessive or uneven wear on nose tire.	Incorrect operating pressure. Wear resulting from shimmy.	Inflate tire to correct pressure. Refer to proceedings for correction.
Nose gear fails to steer properly.	Oleo cylinder binding in strut housing. One brake dragging.	Lubricate strut housing. (Refer to Lubrication Chart.) Cylinder and/or strut housing bushings damaged. Determine cause and correct.

CHEROKEE ARROW III SERVICE MANUAL

TABLE VII-II. TROUBLESHOOTING CHART (LANDING GEAR) (cont)

Trouble	Cause	Remedy
Nose gear fails to steer properly. (cont)	Steering arm roller sheared at top of strut.	Replace defective roller.
	Steering bellcrank loose on attachment plate.	Readjust and tighten.
	Steering bellcrank bearing and/or bolt worn.	Replace bearing and/or bolt.
	Shimmy dampener galling or binding.	Replace.
Nose gear fails to straighten when landing gear extends.	Steering arm roller sheared at top of strut.	Replace defective roller.
	Incorrect rigging of nose gear steering.	Check nose gear steering adjustment.
Nose gear fails to straighten when landing gear retracts.	Centering guide roller sheared.	Replace roller.
	Damaged guide.	Replace guide.
Main landing shimmies during fast taxi, takeoff, or landing.	Tire out of balance.	Check balance and replace tire if necessary.
	Worn or loose wheel bearings.	Replace and/or adjust wheel bearings.
	Worn torque link bolts and/or bushings.	Replace bolts and/or bushings.

CHEROKEE ARROW III SERVICE MANUAL

TABLE VII-II. TROUBLESHOOTING CHART (LANDING GEAR) (cont)

Trouble	Cause	Remedy
Excessive or uneven wear on main tires.	<p>Incorrect operating pressure.</p> <p>Wheel out of alignment (toe in or out).</p> <p>Lower side brace link out of adjustment, allowing gear to slant in or out.</p>	<p>Inflate tire to correct pressure.</p> <p>Check wheel alignment.</p> <p>Check gear adjustment.</p>
Strut bottoms on normal landing or taxiing on rough ground.	<p>Insufficient air and/or fluid in strut.</p> <p>Defective internal parts in strut.</p>	<p>Service strut with air and/or fluid.</p> <p>Replace defective parts.</p>
Landing gear doors fail to completely close.	<p>Landing gear not retracting completely.</p> <p>Door retraction mechanism out of adjustment.</p>	<p>Check adjustment of landing gear.</p> <p>Check adjustment.</p>
Red gear unsafe light and horn fail to stop when throttle is closed and gear has extended. (Gear extended through the use of the free fall lever or lack of air speed.)	<p>Gear selector handle in up position.</p>	<p>Place handle in down position.</p>
AIRCRAFT WITHOUT BACKUP LANDING GEAR SYSTEM		
Warning horn continually operates regardless of flap position.	<p>Faulty switch.</p> <p>Switch out of adjustment.</p>	<p>Replace switch.</p> <p>Adjust switch.</p>

CHEROKEE ARROW III SERVICE MANUAL

TABLE VII-II. TROUBLESHOOTING CHART (LANDING GEAR) (cont)

Trouble	Cause	Remedy
Red gear unsafe light and horn fail to operate when selector is moved to up position with gear extended and throttle retarded.	Warning light and horn circuit wire broken.	Check wiring.
Above condition on ground.	Defective safety (squat) switch.	Replace switch.
Above condition in the air.	Pressure switch open.	Replace switch.
Hydraulic pump shuts off, but red gear unsafe light remains on.	Gear not fully retracted.	Determine cause and remedy.

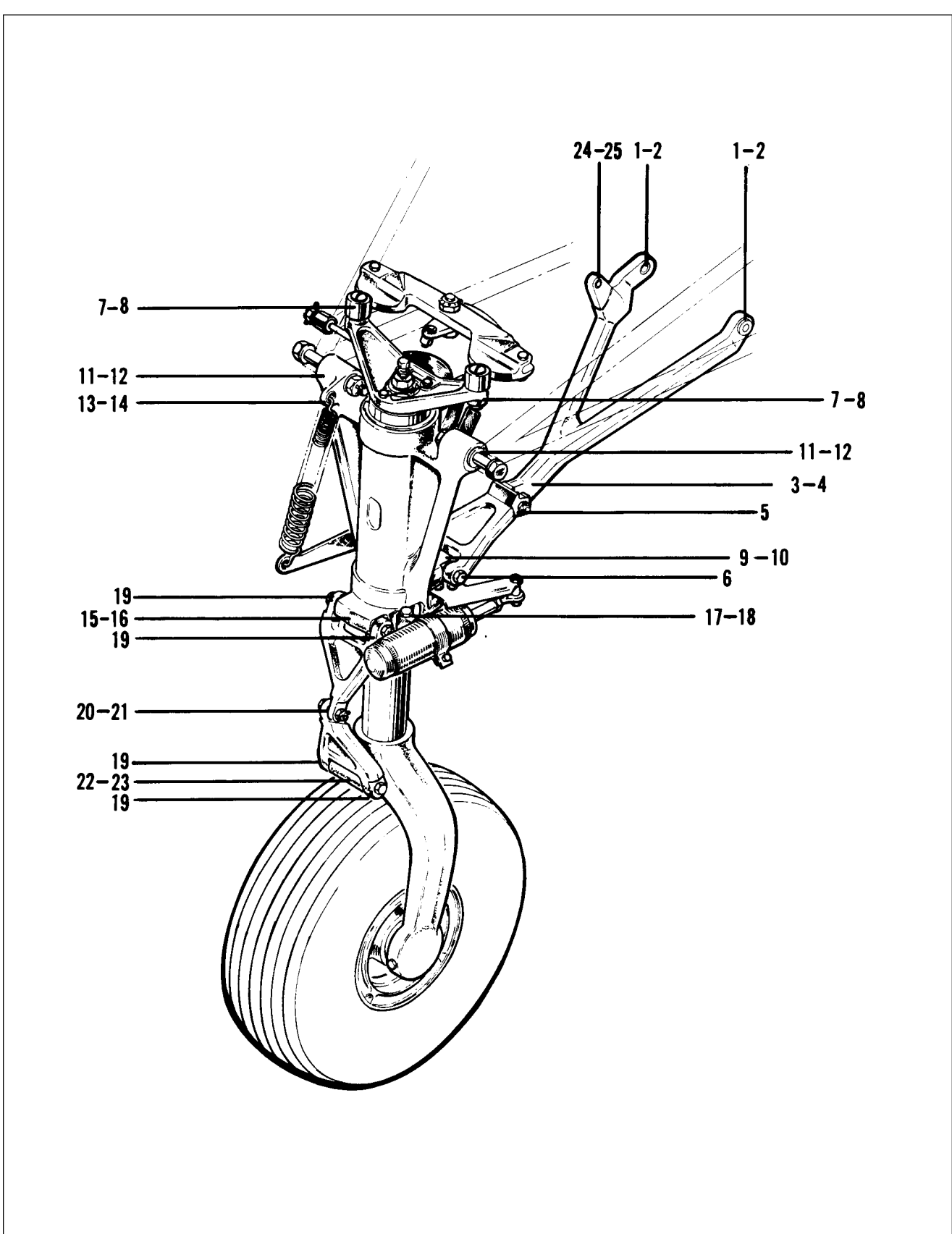

Figure 7-27. Nose Gear Service Tolerances

*** CHEROKEE ARROW III SERVICE MANUAL**

TABLE VII-III. NOSE GEAR SERVICE TOLERANCES

Fig. No	Part No	Nomenclature	Manufacturers Dimension	Service Dimension	Service Tol.	Remarks
1	67146-00	Drag link, upper	ID .6235 .6245	ID .6230 .6250	002	
2	452 474 (F632-1)	Bearing, upper drag link	** ID .4385 .4375	ID .4395 .4375	002	
3	65003-45*	Bushing	ID	ID		
4	67146-00	Drag link upper	ID .378 .379	ID .3775 .3795	002	
5	452 450 (FF310-5)	Bearing upper drag link	** ID .2495 .2505	ID .2495 .2515	002	
6	67144-00	Drag link, lower	ID .2495 .2505	ID .2495 .2515	002	
7	67144-00	Drag link, lower	ID .3120 .3130	ID .3120 .3140	002	
8	44386-2	Steering arm	ID .4370 .4385	ID .4370 .4385	0015	
9	14976-11	Bushing, steering arm	** ID .312 .313	ID .312 .314	002	Press fit
10	67054-03	Trunnion housing drag link attachment	ID .4415 .4425	ID .4415 .4425	0015	
11	67026-07	Bearing trunnion housing drag link attachment	ID .312 .313	ID .312 .314	002	
12	67054-03	Trunnion assembly main attachment fitting	ID .6285 .6295	ID .6285 .6295	001	
13	67026-11	Bushing, trunnion assembly attachment	** ID .5000 .5015	ID .5000 .5030	003	
* Used with 452 474 bearing			**Line ream to this dimension after installation of new part			

*** CHEROKEE ARROW III SERVICE MANUAL**

TABLE VII-III. NOSE GEAR SERVICE TOLERANCES (cont)

Fig. No	Part No	Nomenclature	Manufacturers Dimension	Service Dimension	Service Tol.	Remarks
13	67054-03	Trunnion assembly assist spring fining	ID .302 .303	ID .302 .3035	0015	
14	95061-144	Bearing, assist spring fining	ID .240 .250	ID .249 .259	010	Install using Loctite 601
15	67148-00	Tube assembly torque link fining	ID .4370 .4385	ID .4370 .4385	0015	
16	67026-07	Bearing, tube assembly torque link fitting	** ID .314 313	ID .3155 .3130	0025	Press fit
17	67148-00	Shimmy damper fitting	ID .3745 .3760	ID .3745 .3760	0017	
18	21831-04	Shimmy damper fitting bearing	** ID .249	ID .247 .251	003 .252	
19	20735-05	Torque link	ID .312 .313	ID .312 .314	002	
20	20735-00	Torque link	ID .377 .3785	ID .377 .3790	002	
21	452 366 (#F-310-5)	Bearing, torque link	** ID .2495	ID .2495 .2505	002 .2515	Coat bearing with zinc chromate and install while still wet Press fit
22	67099-00	Fork assembly - torque link fitting	ID .4370	ID .4370 .4385	0015 .4385	
23	67026-07	Bearing, fork assembly torque link fitting (FF411 -4)	** ID .312 .313	ID .312 .314	002	
24	67146-00	Drag link, upper	ID .372 .373			
25	63900-120	Bushing, upper drag link	ID .2495 .2500			

* Used with 452 474 bearing

**Line ream to this dimension after installation of new part

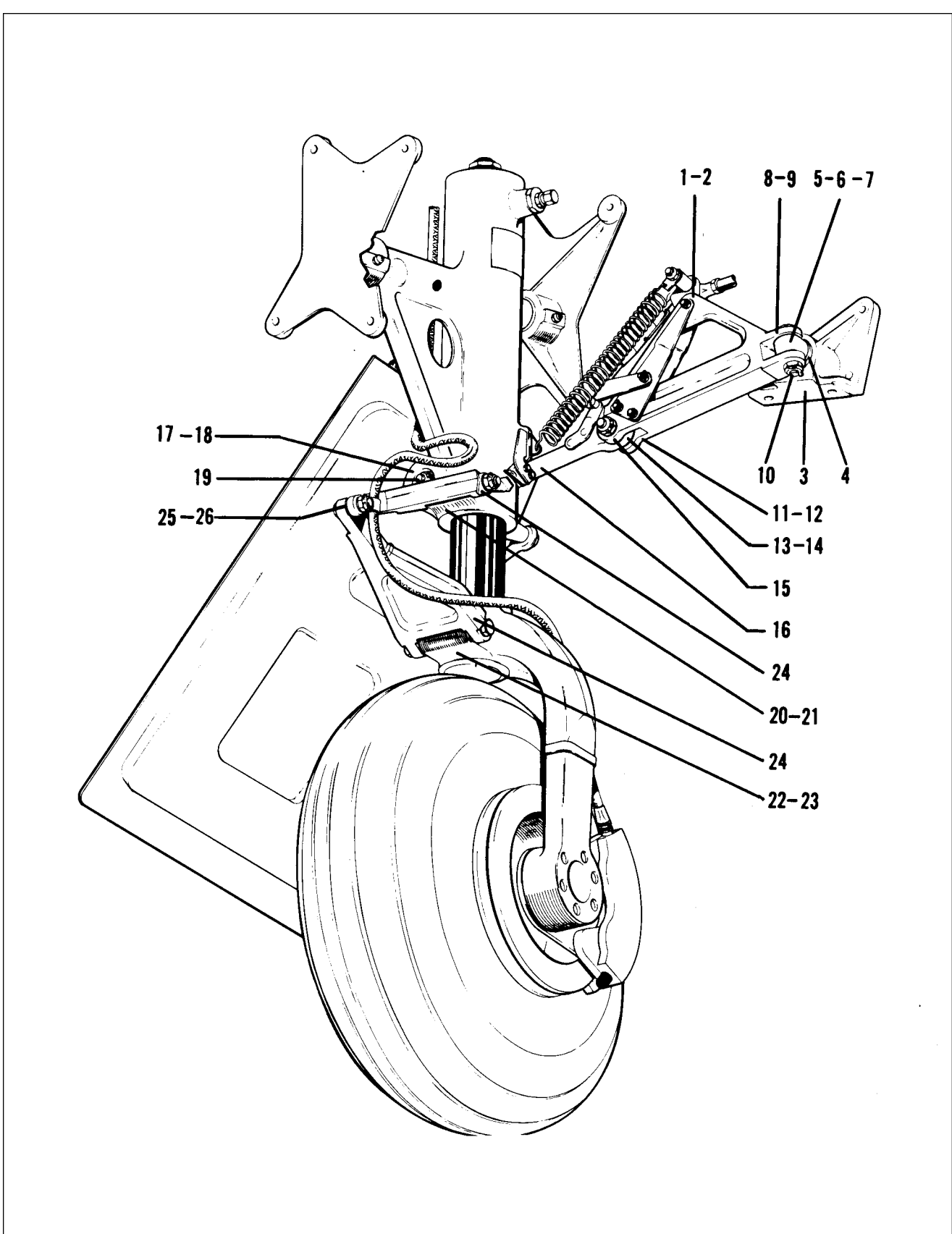

Figure 7-28. Main Gear Service Tolerances

*** CHEROKEE ARROW III SERVICE MANUAL**

TABLE VII-IV. MAIN GEAR SERVICE TOLERANCES

Fig. No	Part No	Nomenclature	Manufacturers Dimension	Service Dimension	Service Tol.	Remarks
1	67514-0	Link, upperside brace	ID .3645 .3625	ID		
2	63900-89	Bushing, upperside brace link	** ID .249 .251	ID .248 .252	.004	Press Fit
3	95642-4 95642-5	Bracket, side brace support	ID .7495 .7505	ID .7490 .7510	.002	
4	67026-12	Bushing, support bracket	ID .624 .625	ID .624 .626		Install using Loctite 601.
5	78717-2	Stud, side brace support	O D .6235 .6225	O D .6220		
6	78717-2	Stud, side brace support	ID .4365 .4385	ID .4355 .4395	.004	
7	65003-41	Bushing, side brace support stud	ID .373 .375	ID .372 .376	.004	
8	67025-2	Link, upperside brace	ID .4945 .4935	ID .4925		
9	14843-16 (2)	Bushing, side brace link	** ID .376 .375	ID .374		Press Fit. Install using Loctite 601.
10	400 761 (AN26-25)	Bolt, link, stud attaching	O D .373 +0 -.002	O D .373 +0 -.004	.004	
11	67514-0	Link, upperside brace	ID .4945 .4935	ID .4925		
12	14843-16 (2)	Bushing, side brace link	** ID .3745	ID .374 .3755		Press Fit
13	67797-04 67797-05	Link, lowerside brace	ID .4905	ID .500 .4925		
14	65003-44 (2)	Bushing, lowerside brace link	** ID .373 .375	ID .372 3.76	.004	Press Fit

** Line ream to this dimension after installation of new part

*** CHEROKEE ARROW III SERVICE MANUAL**

TABLE VII-IV. MAIN GEAR SERVICE TOLERANCES (cont)

Fig. No	Part No	Nomenclature	Manufacturers Dimension	Service Dimension	Service Tol.	Remarks
15	402 927 NAS 464 616	Bolt, side brace link assembly	OD .3742 + .0000 -.0005	OD .3740		
16	452368 (HFX-8TG)	Rod end, lowerside brace link	ID .50+0015 -.0005	ID .50+0030 -.0005	0035	
17	67926-04 67926-05	Trunnion housing, side brace attachment	ID .7530 .7550	ID .7530 .7550		
18	67026-05	Bushing, Trunnion	ID .499 .500	ID .498 .502	004	Install bearing with wet zinc chromate on adjacent surfaces of bearing and casting
19	402 960 (NAS 464 P8A-44)	Bolt, Trunnion/side brace attaching	OD .4991 + .0000 - .0009	OD .4972		
20	67926-04 67926-05	Trunnion housing, torque link attachment	ID .4410 .4430	ID .4410 .4440		
21	67026-07 (2)	Bearing, Trunnion	** ID .314 .313	ID .315		Press Fit Install using Loctite 601
22	67037-06	Strut Assembly	ID .4385 .4370	ID .4395 .4370	0025	
23	67026-07 (2)	Bearing, strut	** ID .314 .313	ID .315 .313	002	Press Fit
24	67012-00	Torque link(2)	ID .312+001 .0000	ID .312+002 -.000	002	
25	67012-00	Torque link (2)	ID .3760 .3745	ID .3745 .3745	0025	
26	31796-00 (2)	Bushing, Torque link	** ID .252 .251	ID .253 .251	002	Press Fit

** Line ream to this dimension after installation of new part

**GRIDS 1L15 THRU 1L24
INTENTIONALLY LEFT BLANK**

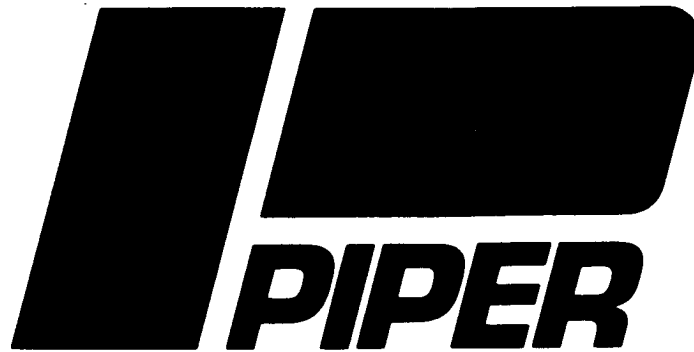

**ARROW III - TURBO ARROW III
ARROW**

SERVICE MANUAL

CARD 2 OF 3

PA-28R-201/201T

Courtesy of Bomar Flying Service
www.bomar.biz

PIPER AIRCRAFT CORPORATION

(PART NUMBER 761 639)

2A1

CHEROKEE ARROW III SERVICE MANUAL

AEROFICHE EXPLANATION AND REVISION STATUS

Service manual information incorporated in this set of Aerofiche cards is arranged in accordance with the general specifications of Aerofiche adopted by the General Aviation Manufacturer's Association. Information compiled in this Aerofiche service manual is kept current by revisions distributed periodically. These revisions supersede all previous revisions, are complete Aerofiche card replacements, and supersede Aerofiche cards of the same number in the set.

Identification of revised material:

Revised text and illustrations are indicated by a black vertical line along the left-hand margin of the frame, opposite revised or added material. Revision lines indicate only current revisions with changes and additions to existing text and illustrations. Changes in capitalization, spelling, punctuation, indexing, the physical location of the material, or complete page additions are not identified by revision lines.

Revisions to Service Manual 761 639 issued December 15, 1976 are as follows:

Effectivity	Publication Date	Aerofiche Card Effectivity
ORG761215	December 15, 1976	1 and 2
PR770831	August 31, 1977	1 and 2
PR781211	December 11, 1978	1 and 2
PR800501	May 1, 1980	1 and 2
PR801121	November 21, 1980	1 and 2
PR810713	July 13, 1981	1 and 2
PR831018	October 18, 1983	1 and 2
IR860730	July 30, 1986	1
IR860920	September 20, 1986	1
IR870506	July 12, 1987	1
PR890213	August 1, 1989	1, 2 and 3
IR950221	February 21, 1995	1 and 2
IR040227*	February 27, 2004	1 and 2

***INTERIM CHANGE TO SERVICE MANUAL 761 639**

Section VII in Card 1 and Sections VIII and VIHA in Card 2 have been revised. There are no other changes included in this interim change revision. Please discard your current cards 1 and 2, and replace them with the revised ones. DO NOT DISCARD CARD 3.

Consult the latest Customer Services Information Aerofiche for current revision dates for this manual.

TABLE OF CONTENTS

NO.	AEROFICHE CARD NO. 1	GRID NO
I	INTRODUCTION	1A13
II	HANDLING AND SERVICING	1A16
III	INSPECTION	1D1
IV	STRUCTURES	1D17
V	SURFACE CONTROLS	1F6
VI	HYDRAULIC SYSTEM	1H5
VII	LANDING GEAR AND BRAKE SYSTEM	1I22
AEROFICHE CARD NO. 2		
VIII	POWER PLANT (CONTINENTAL)	2A9
VIIIA	POWER PLANT (LYCOMING)	2C18
IX	FUEL SYSTEM	2E8
X	INSTRUMENTS	2F5
XI	ELECTRICAL SYSTEM	2G15
XII	ELECTRONICS	2J19
XIII	HEATING AND VENTILATING	2K5
AEROFICHE CARD NO. 3		
XIV	ACCESSORIES AND UTILITIES	3A5

LIST OF ILLUSTRATIONS (cont)

Figure		Aerofiche Grid No.
8-1.	Engine Cowling Installation.....	2A13
8-3.	Propeller Installation	2A14
8-4.	Propeller Blade Minor Repair	2A16
8-5.	Propeller Governor.....	2A17
8-6.	Engine Installation.....	2A20
8-7.	Schematic Diagram of Turbocharger System.....	2A23
8-8.	Induction System Installation.....	2B5
8-8a.	Magneto Assembly.....	2B7
8-9.	Contact Spring Inspection	2B8
8-10.	Contact Points.....	2B9
8-11.	Impulse Coupling	2B10
8-12.	Flyweight Clearance of Impulse Coupling.....	2B10
8-13.	Rotor Holding Tool Installed.....	2B11
8-14.	Timing Kit Installed.....	2B11
8-15.	Cast-In Timing Marks.....	2B12
8-16.	Fabricated Pointer.....	2B12
8-17.	Engine Timing Marks.....	2B13
8-18.	Removing Spring From Lead Assembly.....	2B15
8-19.	Assembly Tool.....	2B17
8-20.	Assembly Tool Application.....	2B17
8-21.	Measuring Lead Assembly Length.....	2B17
8-22.	Ferrule Seating Tool	2B19
8-23.	Measuring Wire From Top of Ferrule	2B19
8-24.	Needle.....	2B19
8-25.	Installing Grommet Over Lead Assemblies	2B19
8-26.	Lead Assembly Installed in Grommet.....	2B20
8-27.	Wire Doubled Over For Installation of Eyelet	2B20
8-28.	Ignition Schematic.....	2B21
8-29.	Removing Frozen Spark Plug.....	2B23
8-30.	Lubrication System Maintenance Points.....	2B24
8-31.	Schematic Diagram of Fuel Injection System.....	2C2
8-32.	Fuel Injection Nozzle Assembly	2C3
8-33.	Engine Controls.....	2C4
8-34.	Idle Speed and Mixture Adjustment Points.....	2C6
8-35.	Sectional View of Altitude Compensating Fuel Pump Assembly.....	2C8
8-36.	Exhaust Bypass Screw.....	2C10
8A-1.	Propeller Installation (Hartzell).....	2C21
8A-2.	Propeller Blade Minor Repair	2C22
8A-3.	Propeller Governor.....	2C24
8A-3a.	Engine Cowling Installation.....	2D2
8A-4.	Engine Installation (PA-28R-201).....	2D4
8A-4a.	Adjustment of Engine Controls.....	2D7
8A-5.	Fuel Injector.....	2D8
8A-6.	Schematic Diagram of RSA Injector System.....	2D9

LIST OF ILLUSTRATIONS (cont)

Figure		Aerofiche Grid No.
8A-7.	Fuel-Air Bleed Nozzle.....	2D11
8A-8.	Contact Points.....	2D13
8A-9.	Rotor Holding Tool Installed.....	2D14
8A-10.	Timing Kit Installed.....	2D14
8A-11.	Aligning Timing Marks.....	2D15
8A-12.	Checking Flyweight Clearance of Impulse Coupling	2D15
8A-13.	Engine Timing Marks.....	2D17
8A-14.	Magneto Adjustment Limits.....	2D17
8A-15.	Magneto Timing Mark.....	2D18
8A-16.	Removing Spring From Lead Assembly.....	2D18
8A-17.	Assembly Tool.....	2D19
8A-18.	Using Assembly Tool.....	2D19
8A-19.	Measuring Lead Assembly Length.....	2D19
8A-20.	Cutting Metallic Braid From End of Lead	2D21
8A-21.	Unbraiding Metallic Shielding.....	2D21
8A-22.	Forming Shielding Around Ferrule.....	2D21
8A-23.	Ferrule Seating Tool	2D21
8A-24.	Needle.....	2D21
8A-25.	Measuring Wire From Top of Ferrule	2D23
8A-26.	Installing Grommet Over Lead Assemblies.....	2D23
8A-27.	Lead Assembly Installed in Grommet.....	2D23
8A-28.	Wire Doubled Over For Installation of Eyelet	2D23
8A-29.	Removing Spark Plug Frozen to Bushing	2E1
9-1.	Fuel System Diagram (PA-28R-201).....	2E11
9-1a.	Fuel System Diagram (PA-28R-201 S/N's 37001 and up).....	2E12
9-2.	Fuel System Diagram (PA-28R-201T).....	2E13
9-3.	Fuel Sender Units Installation.....	2E15
9-4.	Engine Primer System Placard.....	2E16
9-5.	Fuel Quantity Indicator.....	2E19
9-6.	Fuel Filter Bowl and Screen.....	2E20
9-7.	Fuel Pump Variable Resistor.....	2E21
9-8.	Tolerance, Union Nut and Tubing.....	2F2
10-1.	Instrument Panel (Typical)	2F11
10-1a.	Instrument Panel (PA-28R-201 S/N's 2837001 and up).....	2F12
10-1b.	Instrument Panel (PA-28R-201T S/N's 2803001 and up).....	2F13
10-2.	Pitot Static System.....	2F14
10-3.	Vacuum-Auxiliary Vacuum System	2F16
11-2.	Lamp-Bank Load.....	2G20
11-3.	Checking Field Circuit	2G21
11-4.	Testing Field Circuit.....	2G21
11-5.	Testing Rectifiers (Positive)	2G22
11-6.	Testing Rectifiers (Negative).....	2G23
11-7.	C-3928 Fixtures and Adapters.....	2G24
11-8.	Removing Rectifiers.....	2G24
11-9.	Installing Rectifiers	2H1
11-10.	Soldering Rectifiers Lead.....	2H2
11-11.	Testing Stator Coils	2H3
11-12.	Removing End Bearing	2H4

LIST OF ILLUSTRATIONS (cont)

Figure		Aerofiche Grid No.
11-13.	Installing End Bearing.....	2H4
11-14.	Removing Drive Pulley.....	2H5
11-15.	Removing Drive End Bearing.....	2H5
11-16.	Removing Slip Ring.....	2H6
11-17.	Installing Slip Ring.....	2H6
11-18.	Solder Points.....	2H7
11-19.	Installing Retainer	2H7
11-20.	Installing Drive End Shield and Bearing (Typical).....	2H8
11-21.	Installing Pulley.....	2H8
11-22.	Meter Connections for Alternator Performance Test	2H10
11-23.	Exploded View of Prestolite Alternator.....	2H12
11-24.	Removal of Slip Ring End Bearing.....	2H13
11-25.	Removal of Rectifier	2H13
11-26.	Removal of Drive End Head (PA-28R-201 only).....	2H14
11-27.	Removal of End Head Bearing (Typical).....	2H14
11-28.	Testing Rotor for Ground	2H15
11-29.	Testing Rotor for Shorts	2H15
11-30.	Installation of Drive End Head.....	2H16
11-31.	Installation of Rectifier.....	2H16
11-32.	Terminal Assembly.....	2H17
11-33.	Slip Ring End Bearing Assembly.....	2H18
11-34.	Testing Alternator.....	2H18
11-35.	Brush Installation.....	2H19
11-36.	Internal Wiring Diagram.....	2H19
11-37.	Exploded View of Gear Reduction Starting Motor (PA-28R-201)	2H21
11-38.	Exploded View of Starting Motor (PA-28R-201T).....	2H22
11-39.	Turning Starting Motor Commutator.....	2H23
11-40.	Testing Motor Armature for Shorts.....	2H23
11-41.	Testing Motor Fields for Grounds.....	2H24
11-42.	No-Load Test Hook-Up.....	2H24
11-43.	Stall-Torque Hook-Up.....	2I1
11-44.	Strobe Light Connections (Earlier Models)	2I7
11-44a.	Strobe Light Connections (Later Models).....	2I8
11-44b.	Ignition Switch	2I12
11-45.	Terminal Block.....	2I13

NOTE: (Electrical Schematics Figures 11-46 thru 11-67, see Table XI-VIII.)

12-1.	ELT Schematic (Typical).....	2K3
12-2.	ELT Portable Folding Antenna (Narco)	2K4
12-3.	ELT Using Fixed Aircraft Antenna (Narco).....	2K4
13-1.	Cabin Heater and Defroster (PA-28R-201)	2K7
13-2.	Cabin Heater and Defroster (PA-28R-201T).....	2K8
13-3.	Overhead Vent System and Fresh Air System.....	2K9

LIST OF TABLES

Table	Aerofiche Grid No.
VIII-I. Propeller Specifications.....	2A16
VIII-II. Engine Data	2A21
VIII-III. Troubleshooting Chart (Engine).....	2C12
VIIIA-I. Propeller Specifications.....	2D1
VIIIA-II. Engine Troubleshooting.....	2E3
IX-I. Fuel Sender Locations.....	2E16
IX-II. Fuel Quantity Transmitter Calibration Tolerances.....	2E18
IX-III. Transmitter Fuel Gauge Tolerances.....	2E23
IX-IV. Troubleshooting Chart (Fuel System)	2F3
X-I. Vacuum System.....	2F19
X-II. Directional Gyro Indicator	2F21
X-III. GYRO Horizon Indicator.....	2F22
X-IV. Rate of Climb Indicator.....	2F24
X-V. Altimeter.....	2G1
X-VI. Airspeed Tubes and Indicator.....	2G3
X-VII. Magnetic Compass	2G5
X-VIII. Manifold Pressure Indicator	2G6
X-IX. Tachometer	2G7
X-X. Engine Oil Pressure Gauge.....	2G8
X-XI. Fuel Pressure Gauge.....	2G9
X-XII. Turn and Bank Indicator.....	2G10
X-XII. Fuel Quantity Indicators.....	2G11
X-XIV. Oil Temperature Indicators.....	2G12
X-XV. Cylinder Head Temperature Gauge.....	2G14
XI-I. Alternator Belt Tension	2H10
XI-II. Alternator Specifications.....	2H18
XI-III. Starting Motor Service Test Specifications.....	2I3
XI-IV. Hydrometer Reading and Battery Charge Percent	2I4
XI-V. Electrical System Troubleshooting.....	2I14
XI-VI. Electrical Symbols.....	2J4
XI-VII. Electrical Wire Coding.....	2J5
XI-VIII. Index - Electrical System Schematics	2J6

LIST OF CHARTS

Chart	Grid No.
VIII-I. Metered Fuel Assembly Calibration.....	2C10
VIII-II. Limits - Fuel Flow Vs. Brake H.P.	2C11

THIS PAGE INTENTIONALLY LEFT BLANK

SECTION VIII
POWER PLANT [CONTINENTAL]

Paragraph	Aerofiche Grid No.
8-1. Introduction	2A11
8-1a. Standard Practices - Engine.....	2A11
8-2. Description	2A12
8-3. Troubleshooting.....	2A12
8-4. Engine Cowling.....	2A12
8-5. Removal of Engine Cowling.....	2A12
8-6. Cleaning, Inspection and Repair of Engine Cowling.....	2A12
8-7. Installation of Engine Cowling.....	2A13
8-8. Propeller	2A13
8-9. Removal of Propeller.....	2A13
8-10. Cleaning, Inspection and Repair of Propeller.....	2A15
8-11. Installation of Propeller.....	2A15
8-12. Checking Propeller Blade Track.....	2A17
8-13. Propeller Governor.....	2A17
8-14. Removal of Propeller Governor	2A17
8-15. Installation of Propeller Governor.....	2A18
8-16. Rigging and Adjustment of Propeller Governor	2A18
8-17. Engine.....	2A19
8-18. Removal of Engine.....	2A19
8-19. Installation of Engine	2A22
8-20. Engine Shock Mounts.....	2A24
8-21. Replacement of Engine Shock Mounts	2A24
8-22. Turbocharger.....	2A24
8-22a. Turbocharger Nomenclature.....	2A24
8-23. Removal of Turbocharger.....	2B3
8-24. Installation of Turbocharger	2B3
8-25. Adjustment of Turbocharger.....	2B4
8-26. Overboost Valve	2B4
8-27. Removal of Overboost Valve.....	2B4
8-28. Installation of Overboost Valve.....	2B4
8-29. Induction System Air Filter.....	2B4
8-30. Removal of Air Filter	2B4
8-31. Cleaning Induction Air Filter	2B5
8-32. Installation of Air Filter.....	2B6
8-33. Alternate Air Door.....	2B6
8-34. Ignition System.....	2B6

Paragraph	Aerofiche Grid No.
8-35. Magnetos	2B6
8-36. Inspection of Magnetos	2B6
8-37. Removal of Magnetos.....	2B10
8-38. Magneto Timing Procedure (Internal Timing)	2B11
8-39. Magneto Installation and Timing Procedure (Magneto to Engine).....	2B13
8-40. Harness Assembly.....	2B14
8-41. Inspection of Harness.....	2B14
8-42. Removal of Harness	2B15
8-43. Maintenance of Harness.....	2B16
8-44. Installation of Harness.....	2B20
8-45. Spark Plugs.....	2B22
8-46. Removal of Spark Plugs.....	2B22
8-47. Inspection and Cleaning of Spark Plugs.....	2B23
8-48. Installation of Spark Plugs.....	2B23
8-49. Lubrication System.....	2B24
8-50. Description	2B24
8-51. Oil Filter Replacement	2C1
8-52. Engine Fuel System.....	2C1
8-53. Description	2C1
8-54. Fuel Injection System Maintenance	2C1
8-55. Fuel Injector Nozzle Assembly	2C3
8-56. Removal of Fuel Injector Nozzles.....	2C3
8-57. Cleaning and Inspection of Fuel Injector Nozzles.....	2C3
8-58. Installation of Fuel Injector Nozzles	2C3
8-59. Engine and Propeller Controls.....	2C5
8-60. Rigging Throttle, Mixture and Governor Controls.....	2C5
8-61. Engine Setup Procedures.....	2C5

CHEROKEE ARROW III SERVICE MANUAL

SECTION VIII

POWER PLANT TURBOCHARGED CONTINENTAL (PA-28R-201T)

WARNING

When servicing or inspecting vendor equipment installed in Piper Aircraft, it is the user's responsibility to refer to the applicable vendor publication.

8-1. INTRODUCTION. The purpose of this section is to provide instructions for the removal, minor repair, service and installation of the engine and components. For instructions on major repairs and overhauls, consult the appropriate publication of the component manufacturer.

8-1a. STANDARD PRACTICES - ENGINE. The following suggestions should be applied wherever they are needed when working on the power plant.

1. To ensure proper reinstallation and/or assembly, tag and mark all parts, clips, and brackets as to their location prior to their removal and/or disassembly.
2. During removal of various tubes or engine parts, inspect them for indications of scoring, burning or other undesirable conditions. To facilitate reinstallation, observe the location of each part during removal. Tag any unserviceable part and/or units for investigation and possible repair.
3. Extreme care must be taken to prevent foreign mater from entering the engine, such as lockwire, washers, nuts, dirt, dust, etc. This precaution applies whenever work is done on the engine, either on or off the aircraft. Suitable protective caps, plugs, and covers must be used to protect all openings as they are exposed.

NOTE

Dust caps used to protect open lines must always be installed OVER the tube ends and NOT IN the tube ends. Flow through the lines may be blocked off if lines are inadvertently installed with dust caps in the tube ends.

4. Should any items be dropped into the engine, the assembly process must stop and the item removed, even though this may require considerable time and labor. Ensure that all parts are thoroughly clean before assembling.
5. Never reuse any lockwire, lockwashers, tablocks, tabwashers or cotter pins. All lockwire and cotter pins must fit snugly in holes drilled in studs and bolts for locking purposes. Cotter pins should be installed so the head fits into the castellation of the nut, and unless otherwise specified, bend one end of the pin back over the stud or bolt and the other end down flat against the nut. Use only corrosion resistant steel lockwire and/or cotter pins. Bushing plugs shall be lockwired to the assembly base or case. Do not lockwire the plug to the bushings.
6. All gaskets, packings and rubber parts must be replaced with new items of the same type at reassembly. Ensure the new nonmetallic parts being installed show no sign of having deteriorated in storage.
7. When installing engine parts which require the use of a hammer to facilitate assembly or installation, use only a plastic or rawhide hammer.
8. Anti-seize lubrication should be applied to all loose-fit spline drives which are external to the engine and have no other means of lubrication. For certain assembly procedures, molybdenum disulfide in either paste or powdered form mixed with engine oil or grease may be used.

CAUTION

Ensure that anti-seize compounds are applied in thin even coats and that excess compound is completely removed to avoid contamination of adjacent parts.

CHEROKEE ARROW III SERVICE MANUAL

8-2. DESCRIPTION. The PA-28R-201T is powered by a Teledyne Continental TSIO-360-F turbocharged, overhead valve, air cooled, horizontally opposed, direct drive, wet sump engine rated at 200 hp from sea level to 12,000 feet density altitude.

The engine is enclosed by a cowling consisting of an upper, lower and nose section.

The propeller is a Hartzell constant speed, controlled by a governor mounted on the engine supplying oil through the propeller shaft at various pressures. Oil pressure from the governor moves the blades into high pitch (low RPM). The centrifugal twisting moment of the blade also tends to move the blades into low pitch.

Refer to Section IX for description of fuel system and primer operation.

8-3. TROUBLESHOOTING. Troubles peculiar to the power plant are listed in Table VIII-III, along with the probable causes and suggested remedies. When troubleshooting engine, propeller or fuel system, always ground the magneto primary circuit before performing any checks.

8-4. ENGINE COWLING.

8-5. REMOVAL OF ENGINE COWLING. (Refer to Figure 8-1.)

- a. Release the fasteners securing the upper cowl and then remove the upper cowl.
- b. Disconnect fuel drain flex line from the drain valve assembly.
- c. Disconnect the nose gear door rods.
- d. Support the bottom cowl and remove the screws that attach the cowl to the upper nose cowl, engine mount and fuselage.

8-6. CLEANING, INSPECTION AND REPAIR OF ENGINE COWLING.

- a. The cowl should be cleaned with a suitable solvent and then wiped with a clean cloth.
- b. Inspect the cowling for dents, cracks, loose rivets, damaged or missing fasteners and damaged fiberglass areas.
- c. Repair all defects to prevent further damage. Fiberglass repair procedures may be accomplished according to Fiberglass Repairs, Section IV.

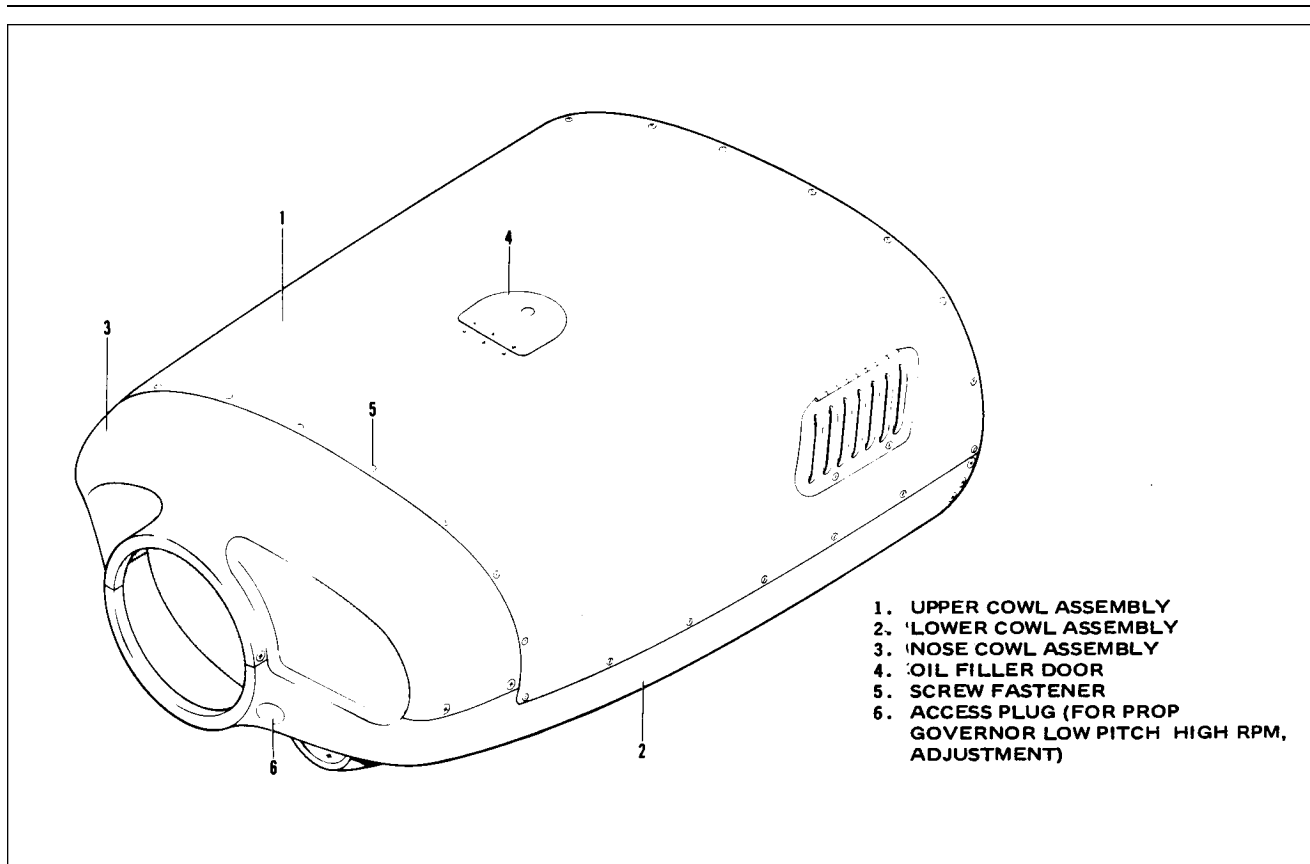

Figure 8-1. Engine Cowling Installation

8-7. INSTALLATION OF ENGINE COWLING. (Refer to Figure 8-1.)

- a. Position the bottom cowl and secure with screw fasteners to the fuselage and engine mount.
- b. Position and connect the upper nose cowl to the lower cowl.
- c. Install the top cowl with attaching screw fasteners.
- d. Attach nose gear door rods.
- e. Connect the fuel drain flex line to the drain valve assembly.

8-8. PROPELLER.

8-9. REMOVAL OF PROPELLER. (Refer to Figure 8-3.)

WARNING

Before performing any work on the propeller, be sure the magneto and master switch is OFF and the mixture control is in the IDLE CUT-OFF position.

- a. Remove the hardware that attaches the nose cowl and remove the cowl. The top and side panels may be removed for greater accessibility.
- b. Remove the safety wire from the propeller mounting nuts and remove the nuts.
- c. Place a drip pan under the propeller to catch oil spillage and pull the propeller from the engine shaft.
- d. If the spinner and spinner bulkhead are to be removed, remove the spinner nose cap attaching screws and cap. Remove the spinner by removing the safety wire and check nut from the propeller at the forward end of the forward spinner bulkhead and the screws that secure the spinner to the aft bulkhead. The aft spinner bulkhead may be removed from the hub by removing the locknuts.

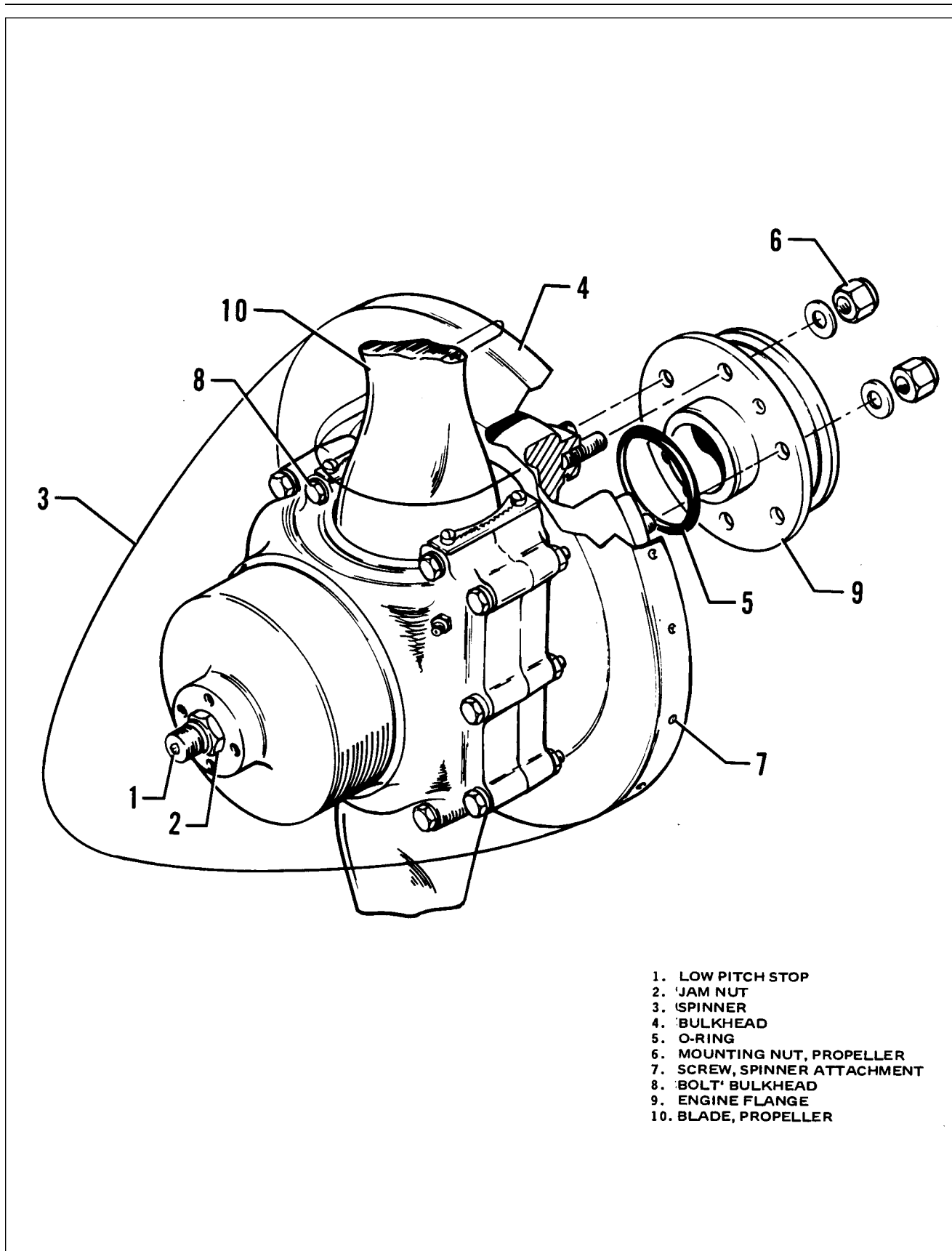

- 1. LOW PITCH STOP
- 2. JAM NUT
- 3. SPINNER
- 4. BULKHEAD
- 5. O-RING
- 6. MOUNTING NUT, PROPELLER
- 7. SCREW, SPINNER ATTACHMENT
- 8. BOLT, BULKHEAD
- 9. ENGINE FLANGE
- 10. BLADE, PROPELLER

Figure 8-3. Propeller Installation

CHEROKEE ARROW III SERVICE MANUAL

8-10. CLEANING, INSPECTION AND REPAIR OF PROPELLER.

NOTE

Do not attempt to disassemble the propeller any further than stated in this manual. For internal repairs and replacement of parts, the propeller should be referred to the Hartzell Factory or Certified Repair Station.

- a. Check for oil and grease leaks.
- b. Clean the spinner, propeller hub, and blades with a non-corrosive solvent.
- c. Inspect the hub parts for cracks.
- d. Steel hub parts should not be permitted to rust. Use aluminum paint to touch up, if necessary, or replating them during overhaul.
- e. Check all visible parts for wear and safety.
- f. Check blades to determine whether they turn freely on the hub pilot tube. This can be done by rocking the blades back and forth through the slight freedom allowed by the pitch change mechanism. If they appear tight and are properly lubricated, the propeller should be disassembled by an authorized Service Center.
- g. Inspect the blades for damage or cracks. Nicks in the leading edges of blades should be filed out and all edges rounded, as cracks sometimes start from such places. Use fine emery cloth for finishing. (Refer to Figure 8-4 for propeller blade care.)
- h. Check the condition of the propeller mounting nuts and studs.
- i. Each blade face should be sanded lightly with fine sandpaper and painted, when necessary, with a flat black paint to retard glare. A light application of oil or wax may be applied to the surfaces to prevent corrosion.
- j. Grease the blade hub through the zerk fittings. Remove one of the two fittings for each propeller blade; alternate the next time. Apply grease through the zerk fitting until fresh grease appears at the fitting hole of the removed fitting. Care should be taken to avoid blowing out the hub gaskets.

8-11. INSTALLATION OF PROPELLER. (Refer to Figure 8-3.)

WARNING

Before performing any work around the propeller be sure the magneto and master switch is OFF, and the mixture control is in the IDLE CUT-OFF position.

- a. Clean the propeller and engine flanges.
- b. Lubricate and install the O-ring in the propeller hub.
- c. Align the propeller with the dowel pins on the prop flange and slide it over the pins.
- d. Tighten the mounting nuts a few threads at a time until all are tight. Stagger torque the nuts 60 to 70 foot-pounds.
- e. Safety the propeller mounting nuts.
- f. Install spinner if removed and torque screws 35 to 40 inch-pounds.

CHEROKEE ARROW III SERVICE MANUAL

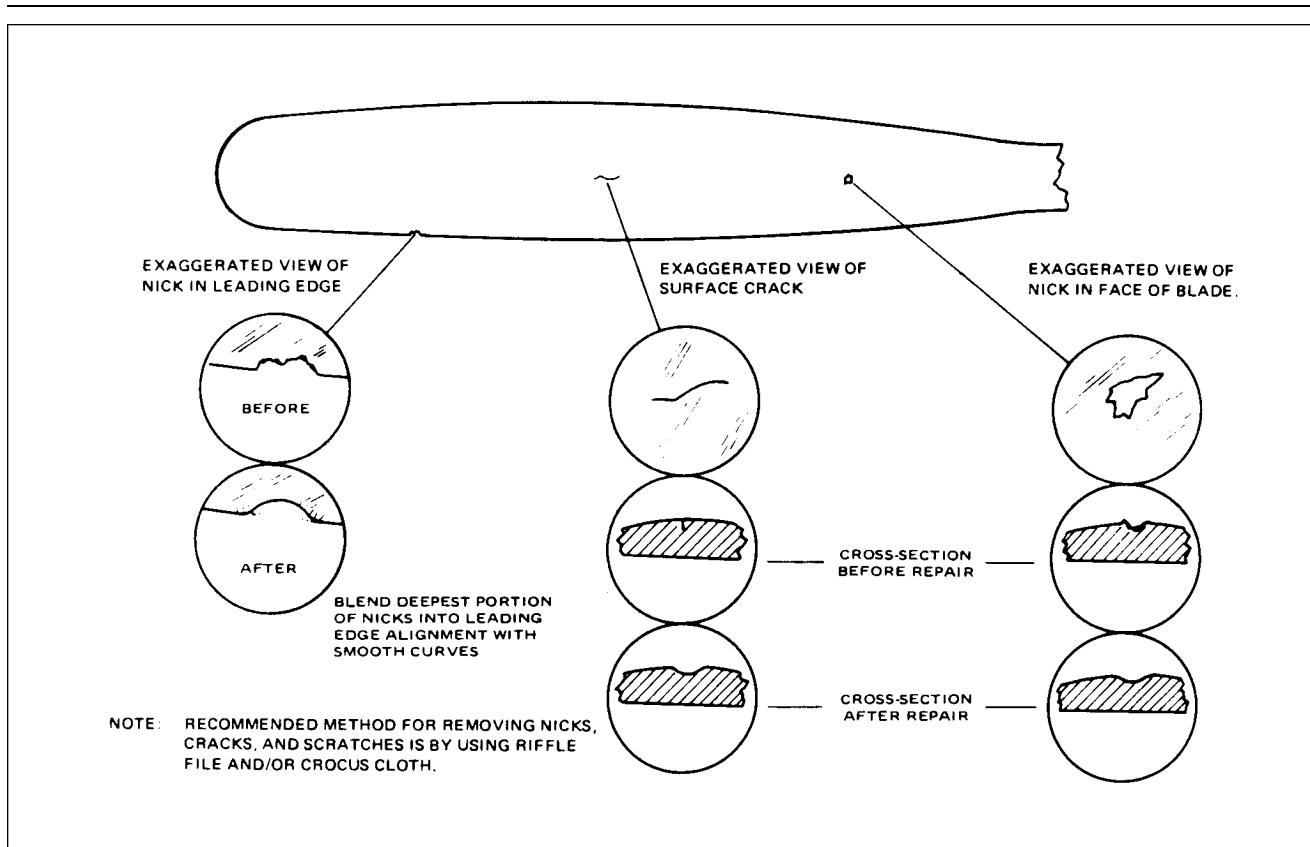

Figure 8-4. Propeller Blade Minor Repair

TABLE VIII-I. PROPELLER SPECIFICATIONS

Blade Angle ⁽¹⁾	Low Pitch (High RPM) High Pitch (Low RPM)	14.4° ± 0.2° 29° ± 1.0°
Propeller RPM Setting	Engine Static High RPM	2575 RPM max.
Propeller Torque Limits	Description	Required Torque (Dry)
	Spinner Bulkhead (Aft)	20-22 foot-pounds
	Propeller Mounting	60-70 foot-pounds
	Spinner Attachment Screws	35-40 inch-pounds

(1) MEASURED AT 30 INCH STATION.

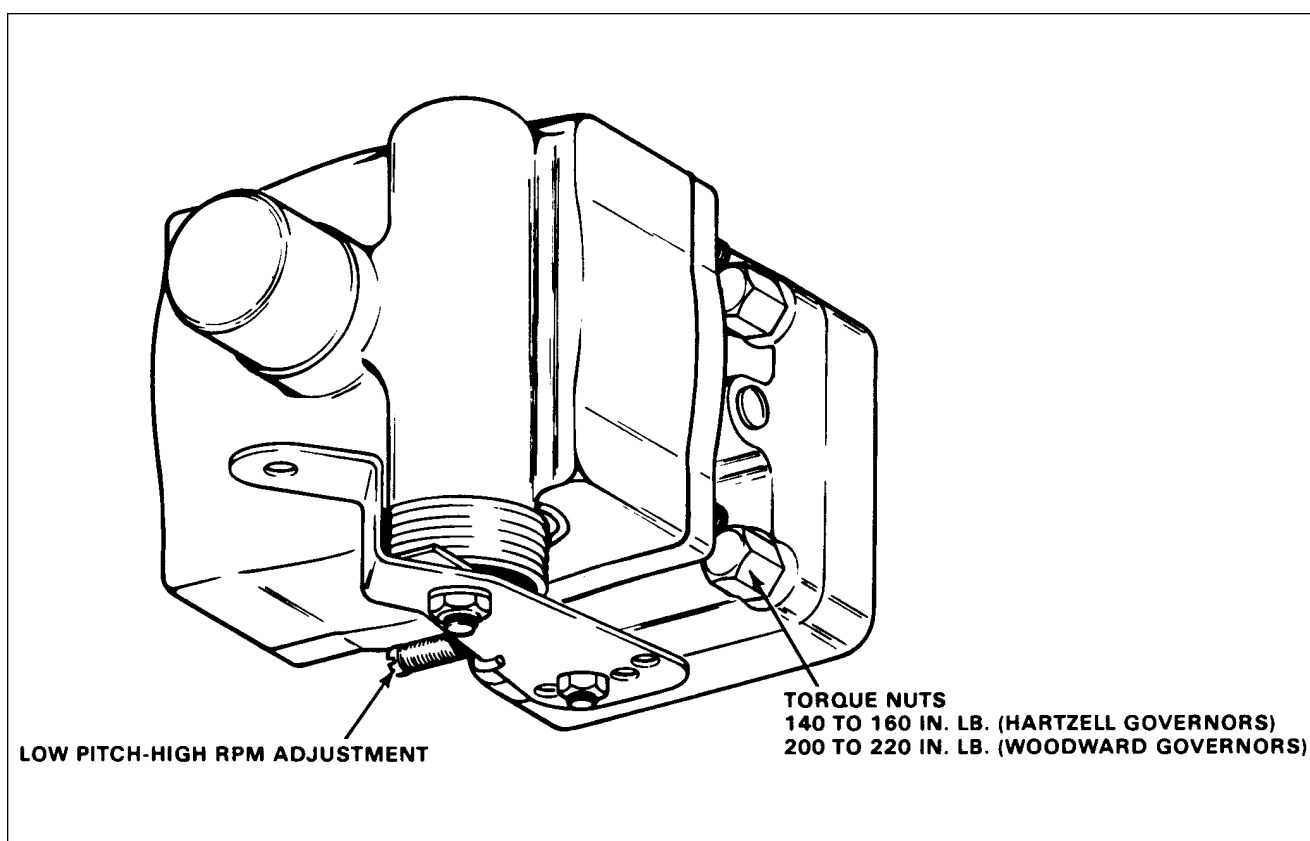

Figure 8-5. Propeller Governor

8-12. CHECKING PROPELLER BLADE TRACK. Blade track is the ability of one blade tip to follow the other, while rotating, in almost the same plane. Excessive difference in blade track - more than .0625 inch may be an indication of bent blades or improper propeller installation. Check blade track as follows:

- a. With the engine shut down and blades vertical, secure to the aircraft a smooth board just under the tip of the lower blade. Move the tip fore and aft through its full "blade-shake" travel, making small marks with a pencil at each position. Then center the tip between these marks and scribe a line on the board for the full width of the tip.
- b. Carefully rotate propeller by hand to bring the opposite blade down. Center the tip and scribe a pencil line as before and check that lines are not separated more than .0625 inch.
- c. Propellers having excess blade track should be removed and inspected for bent blades, or for parts of sheared O-ring, or foreign particles, which have lodged between hub and crankshaft mounting faces. Bent blades will require repair and overhaul of assembly.

8-13. PROPELLER GOVERNOR.

8-14. REMOVAL OF PROPELLER GOVERNOR. The propeller governor is mounted on the lower left forward portion of the engine crankcase. Remove the governor as follows:

- a. Remove the lower cowl to gain access to the governor.
- b. Disconnect the governor control cable end from the governor control arm.
- c. Remove the governor mounting nuts and withdraw the governor from the mounting pad. Cover the mounting pad to prevent foreign material from entering the engine.

8-15. INSTALLATION OF PROPELLER GOVERNOR.

- a. Clean the mounting pad and the governor drive shaft thoroughly.
- b. Coat the mounting gasket with Dow Corning release agent or equivalent.
- c. Lubricate the drive shaft with engine oil and install the governor on the mounting pad.
- d. Tighten the mounting bolts evenly and tighten to a final torque as shown in Figure 8-5.
- e. Connect the control cable to the control arm. Check to be sure the attachment bolt does not contact the governor body while moving the control arm through its full travel. Clearance should be .03 minimum.

8-16. RIGGING AND ADJUSTMENT OF PROPELLER GOVERNOR. (Refer to Figure 8-5.)

- a. Start engine; park 90° to wind direction and warm in normal manner.
- b. To check high RPM, low pitch setting, move the propeller control all the way forward. At this position the governor speed control arm should be against the high RPM fine adjusting screw. With the throttle full forward, observe engine RPM, which should stabilize between 2500 and 2575 RPM. A takeoff must be conducted during which the engine RPM should reach 2575 RPM and remain steady.
- c. If the engine RPM does not read 2575 RPM in flight, the high RPM setting must be adjusted as follows:
 1. Land, shut down the engine and remove lower cowl access plug (See Figure 8-1.)
 2. Adjust the governor by means of the fine adjustment screw for 2575 RPM. To do this, loosen the high RPM fine adjustment screw locknut and turn the screw in a clockwise direction to decrease engine speed or in a counterclockwise direction to increase engine speed.

NOTE

One revolution of the fine adjustment screw will increase or decrease the engine speed approximately 20 RPM.

3. Repeat Step b to ascertain proper RPM setting.
4. After setting the proper high RPM adjustment, run the self-locking nut on the fine adjustment screw against the base projection to lock, and install the lower cowl access plug.
- d. With the high RPM adjustment complete, the control system should be adjusted so that the governor control arm will contact the high RPM stop when the cockpit control knob is .032 to .047 of an inch from its full forward stop. To adjust the control knob travel, disconnect the control cable end from the control arm; loosen the cable end jam nut and rotate the end to obtain the desired level clearance. Reconnect the cable end and tighten jam nut. (Lower cowl must be removed to accomplish this adjustment.)
- e. It is usually only necessary to adjust the high RPM (low pitch) setting of the governor control system, as the action automatically takes care of the positive low RPM (high pitch) setting.

CHEROKEE ARROW III SERVICE MANUAL

8-17. ENGINE.

8-18. REMOVAL OF ENGINE. (Refer to Figure 8-6.)

- a. Turn off all electrical switches in the cockpit and disconnect the battery ground wire at the battery.
- b. Move the fuel selector valve in the cockpit to the OFF position.
- c. Remove the engine cowling. (Refer to Paragraph 8-5.)
- d. Remove the propeller. (Refer to Paragraph 8-9.)
- e. Disconnect the starter positive lead and ground lead at the starter.
- f. Disconnect the tachometer cable to the engine.
- g. Disconnect the governor control cable at the governor and cable attachment clamps.
- h. Disconnect the throttle and mixture cables from the fuel-air control unit.
- i. Disconnect the cylinder temperature sender wire at No. 2 cylinder.
- j. Disconnect the fuel pump supply line and vent line from the engine.
- k. Disconnect the exhaust manifold at the turbocharger turbine inlet ("Y" connections) and at each exhaust manifold slip joint adjacent to No. 1 and 2 cylinders.

NOTE

In some manner identify all hoses, wires and lines to facilitate installation. Open fuel, oil, vacuum lines and fittings should be covered to prevent contamination.

- l. Disconnect the magneto "P" leads at the magnetos.
- m. Disconnect the engine vent tube at the engine.
- n. Disconnect the engine oil temperature lead at the aft end of the engine.
- o. Untie the ignition harness, hoses and lines at the aft end of the engine.
- p. Disconnect the pneumatic pump lines at pump and remove fittings from pump.
- q. Disconnect the oil pressure line at the engine.
- r. Disconnect the fuel flow line at the left rear engine baffle.
- s. Disconnect the manifold pressure line at the left rear side of the engine.
- t. Disconnect the alternator leads and the cable attachment clamps.
- u. Attach a one-half ton (minimum) hoist to the hoisting straps and relieve the tension from the engine mounts.

NOTE

Place a tail stand under the tail of the airplane before removing the engine.

- v. Check the engine for any attachments remaining to obstruct its removal.
- w. Drain the engine oil.
- x. Remove the engine mounting bolts and lower mount assembly.
- y. Carefully raise the engine and pull forward to clear the mount. Check to be certain there are no connections remaining to obstruct removal of the engine, and remove the engine from the aircraft and place on a suitable stand.

CHEROKEE ARROW III SERVICE MANUAL

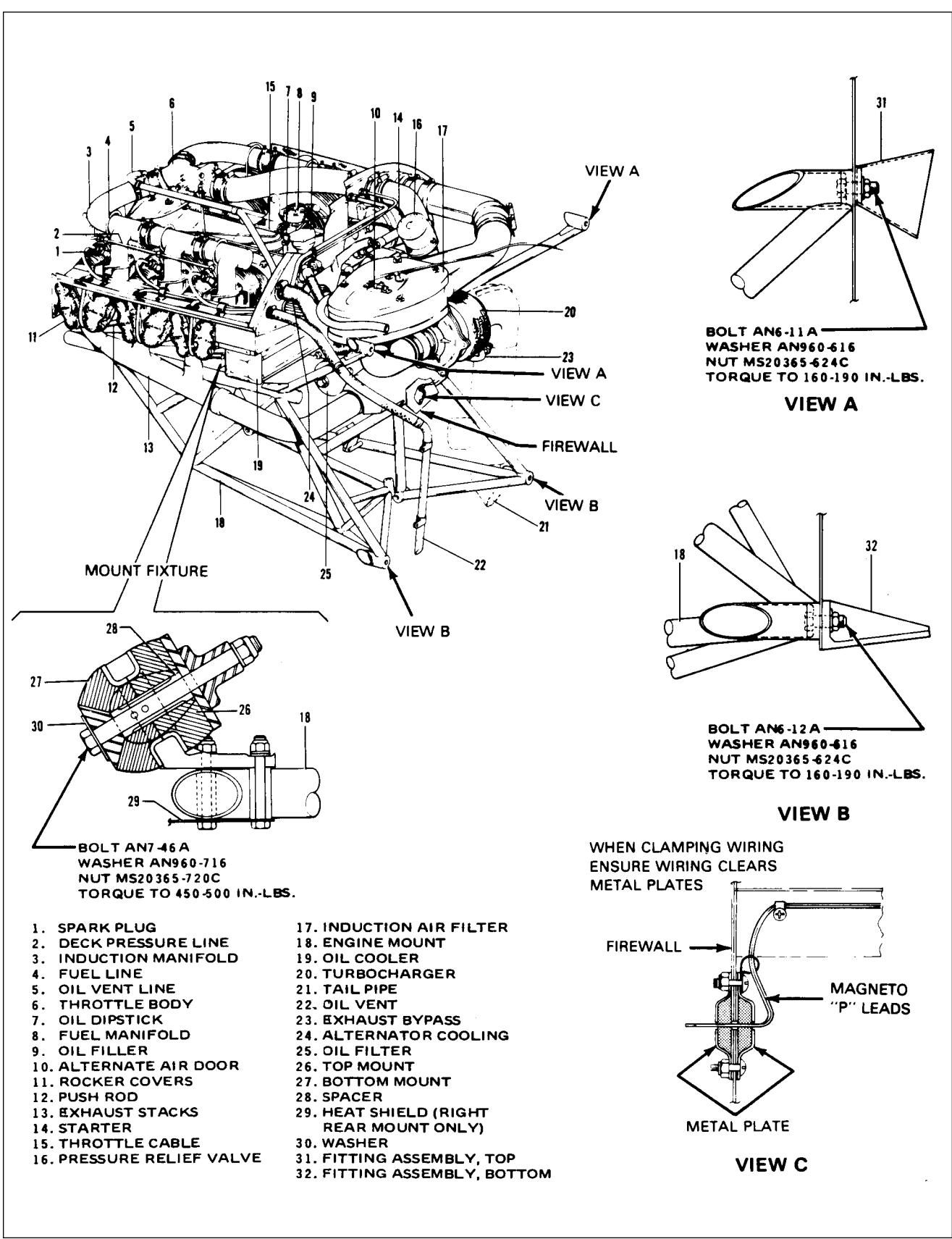

Figure 8-6. Engine Installation

CHEROKEE ARROW III SERVICE MANUAL

TABLE VIII-II. ENGINE DATA

Model (Teledyne Continental)	TSIO-360F or TSIO-360FB
Type Certificate Number	E9CE
Number of Cylinders	6 Horizontally Opposed
Bore (Inches)	4.44
Stroke (Inches)	3.88
Displacement (Cubic Inches)	360
Compression Ratio	7.5:1.
Type of Propeller Drive, Flanged	Direct
Rated Horsepower at Sea Lever, 2575 rpm	200
Fuel, Minimum Octane	100/130 or 100LL
Oil Sump Capacity	8 quarts
Oil Pressure (PSI): @ Max. Continuous Horsepower	
Minimum	30
Normal	30-60
Maximum	*80
Oil Temperature (°F): @ Max. Continuous Horsepower	
Minimum	100
Normal (Desired)	160-200
Maximum	240
Probe Location	Above Oil Filter Element
Cylinder Head Temperature (°F)	
No. 2 cyl.: @ Max. Continuous Horsepower	
Minimum	240
Normal (Desired)	300-400
Maximum	460
Magnetos	Bendix 25 Series
Left Bank	Fires 20° BTC Lower Right, Upper Left
Right Bank	Fires 20° BTC Lower Left, Upper Right
Firing Order:	
TSIO-360F and TSIO-360FB	1-6-3-2-5-4
Spark Plugs (Shielded)	AC, SR86, S86R, HSR86 Auto Lt. PH26, PH260 Champ. REM38W, RHM38W, PHM38EP RHM38E, REM38E, REM38P Red Seal. SE270, SE270P SJ270, SJ270P
Torque	360 to 420 inch-pounds
Alternator	12-volt, 65 ampere
Starter	12-volt, Prestolite
Engine Dry Weight With Accessories (Approx.)	393 pounds
Turbocharger	

*WARNING - OPERATION OF ENGINE AT TOO HIGH AN RPM BEFORE REACHING OIL TEMPERATURE MAY CAUSE LOSS OF OIL PRESSURE.

CHEROKEE ARROW III SERVICE MANUAL

8-19. INSTALLATION OF ENGINE. (Refer to Figure 8-6.) Prior to installing the engine, be sure to install all items that were removed after the engine was removed from the aircraft

WARNING

Prior to installation of the engine, ensure that Teledyne Continental Service Bulletin M86-11 is complied with.

NOTE

Removal all protective caps and identification tags as each item is installed.

NOTE

If engine is equipped with a freon compressor, the compressor support brackets must be properly aligned. Refer to the latest revision of Teledyne Continental Motors Service Bulletin No. M79-15.

- a. Install the shock mount in the engine mount and hoist the engine into position on the mount.
- b. Install the lower shock mount assemblies and mounting bolts. Torque the bolts 450 to 500 inch pounds.
- c. Route and connect the throttle and mixture control cables and adjust.
- d. Route and connect the propeller governor control cable and adjust.
- e. Connect the alternate air cable and adjust.
- f. Reconnect all lines and hoses previously disconnected from the engine.

NOTE

Apply Lubon No. 404 to all male fuel system fittings. Do not allow to enter system.

- g. Route and connect the electrical leads to the appropriate connections on the engine.
- h. Connect the tachometer drive cable.
- i. Connect exhaust manifold at the turbocharger turbine inlet ("Y" connection) and at each exhaust manifold slip joint adjacent to No. 1 and 2 cylinders.

NOTE

Secure all cables, hoses and wires with clamps and Ty-strap in the same location as before removal. Make sure then clamping cables to ensure wiring clears all metal plates and free from forced chaffing against any sharp metal edges, see Figure 8-6.

- j. Install the propeller and spinner per paragraph 8-11.
- k. Service the engine with the proper grade and quantity of oil; refer to Section II.
- l. Be certain all switches are in the OFF position and connect the battery cables.
- m. Install the engine cowling per paragraph 8-7.
- n. Make a final check of the security, location and installation of all lines, wires and cables.
- o. Perform an operational check of the engine; inspect for leaks and make final adjustments to engine controls as required.

NOTE

Check exhaust pipe clearance. Minimum clearance to structure opening should be 0.50 of an inch.

CHEROKEE ARROW III SERVICE MANUAL

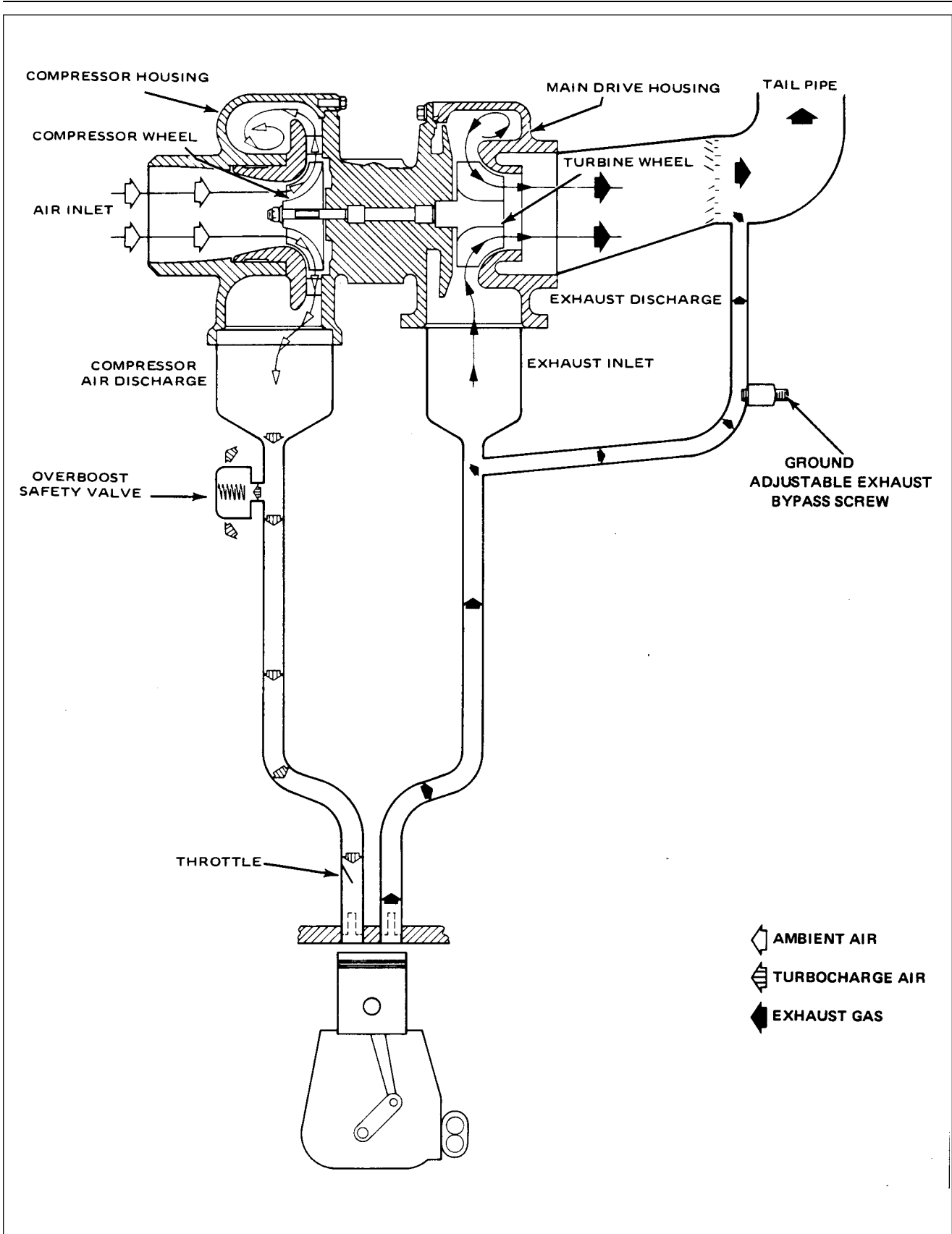

Figure 8-7. Schematic Diagram of Turbocharger System

CHEROKEE ARROW III SERVICE MANUAL

8-20. ENGINE SHOCK MOUNTS.

8-21. REPLACEMENT OF ENGINE SHOCK MOUNTS. (Refer to Figure 8-6.)

- a. Remove the engine cowling per Paragraph 8-5.
- b. Relieve the engine weight on the mounts using a one-half ton hoist attached to the engine lifting points.
- c. Remove the four engine mounting bolts and the lower half of the mount assemblies.
- d. Carefully raise the engine just enough to remove the shock mounts. Check all lines, wires and cables for interference. Disconnect any lines and cables if necessary.
- e. Check all components for wear, damage or cracks and install new mounting kit.
- f. Lower the engine slowly and use mounting bolts to keep the components aligned.
- g. When the engine is supported by the mount, check the mounts for proper seating.
- h. Install the mounting bolt, nut, washer and torque 450 to 500 inch-pounds and safety.
- i. Reconnect any lines, wires or cables that were disconnected and install engine cowling.

8-22. **TURBOCHARGER.** The turbocharger system consists of a turbine and compressor assembly, ground adjustable exhaust bypass screw and the necessary hose and engine air intake ducts. The ground adjustable exhaust bypass screw allows exhaust gas to bypass the turbine and flow directly overboard. In the closed position, the bypass screw diverts the exhaust gases into the turbine. The turbocharger requires little attention between overhauls. However, it is recommended that the items outlined in the Inspection Report, Section III be checked periodically.

8-22a. **TURBOCHARGER NOMENCLATURE.** Many unfamiliar terms may appear on the following pages of this manual. An understanding of these will be helpful, if not necessary, in performing maintenance and troubleshooting. The following is a list of commonly used terms and names as applied to turbocharging and a brief description.

TERM	MEANING
Supercharge	To increase the air pressure (density) above or higher than ambient conditions.
Supercharger	A device that accomplishes the increase in pressure.
Turbo-supercharger	More commonly referred to as a "Turbocharger" this device is driven by a turbine. The turbine is spun by energy extracted from the engine exhaust gas.
Compressor	The portion of a turbocharger that takes in ambient air and compresses it before discharging it to the engine.
Turbine	The exhaust driven end of the turbocharger unit.
Wastegate and Actuator (Exhaust By-Pass)	The wastegate is a butterfly type valve in the exhaust by-pass which, throughout its travel from open to closed, allows varied amounts of exhaust gas to by-pass the turbine, controlling its speed, hence the output of the compressor. The actuator is operated by a hydraulic piston operated by engine oil and cylinder with the piston linked to an arm on the butterfly valve shaft.

CHEROKEE ARROW III SERVICE MANUAL

Density Controller

The density controller is designed to allow the engine to develop full rated power no matter what ambient temperature and pressure conditions are. This controller regulates wastegate bleed oil only at full throttle position to maintain a constant air density at the injector inlet. The pressure and temperature sensing bellows of the controller react to pressure and temperature changes between the fuel injector inlet and the turbocharger compressor. The bellows, filled with dry nitrogen gas, maintains a constant density by allowing the pressure to increase as temperature increases. Movement of the bellows repositions the bleed valve, causing a change in quantity of bleed oil, which changes oil pressure to the wastegate piston.

NOTE

The density controller is designed to keep the air density constant at the injector entrance. As ambient air temperature increases or density decreases due to change in altitude a higher manifold pressure is required to maintain a constant density, also resulting in a higher injector inlet temperature. This is why wide open throttle manifold pressure increases with either altitude or outside air temperature. In a full throttle climb, a gain of 3 to 4 inches of manifold pressure between sea level and critical altitude will be seen.

Differential Pressure Controller

This controller uses a diaphragm rather than a bellows as is found in the density controller. It is used in conjunction with the density controller. Its function is to override the density controller so that the compressor discharge pressure is not held at an unnecessarily high level when lower manifold pressure is being used. The differential controller will usually maintain a compressor discharge pressure (deck pressure) approximately 6.5" Hg above the selected manifold pressure. In this system, the density controller is only effective at wide open engine throttle conditions.

Ground Boosted or Ground Turbocharged

These phrases indicate that the engine depends on a certain amount of turbocharging at sea level to produce the advertised horsepower. An engine that is so designed will usually include a lower compression ratio to avoid detonation.

Deck Pressure

The pressure measured in the area downstream of the turb compressor discharge and upstream of the engine throttle valve. This should not be confused with manifold pressure.

Manifold Pressure

The pressure measured downstream of the engine throttle valve and is almost directly proportioned to the engine power output.

Normalizing

If a turbocharger system is used only to regain power losses caused by decreased air pressure of high altitude, it is considered that the engine has been "normalized".

CHEROKEE ARROW III SERVICE MANUAL

- Overboost** An overboost condition means that manifold pressure is exceeding the limits at which the engine was tested and FAA certified and can be detrimental to the life and performance of the engine. Overboost can be caused by malfunctioning controllers or improperly operating waste gate in the automatic system or by pilot error in a manual controlled system. Refer to latest copy of Lycoming Service Bulletin No. 369.
- Overshoot** Overshoot is a condition of the automatic controls not having the ability to respond quickly enough to check the inertia of the turbocharger speed increase with rapid engine throttle advance. Overshoot differs from overboost in that the high manifold pressure lasts only for a few seconds. This condition can usually be overcome by smooth throttle advance. A good method for advancing the throttle is as follows. After allowing the engine oil to warm up to approximately 140° F, advance the throttle to 28" to 30" manifold pressure, hesitate 1 to 3 seconds and continue advancing to full throttle slow and easy. This will eliminate any overshoot due to turbocharger inertia.
- Bootstrapping** This is a term used in conjunction with turbo machinery. If you were to take all the air coming from a turbocharger compressor and duct it directly back into the turbine of the turbocharger, it would be called a bootstrap system and if no losses were encountered, it would theoretically run continuously. It would also be very unstable because if for some reason the turbo speed would change, the compressor would pump more air to drive the turbine faster, etc. A turbocharged engine above critical altitude (wastegate closed) is similar to the example mentioned above, except now there is an engine placed between the compressor discharge and turbine inlet. Slight system changes caused the exhaust gas to change slightly, which causes the turbine speed to change slightly, which causes the compressor air to the engine to change slightly, which in turn again affects the exhaust gas, etc.
- Critical Altitude** A turbocharged engine's wastegate will be in a partially open position at sea level. As the aircraft is flown to higher altitude (low ambient pressures) the wastegate closes gradually to maintain the preselected manifold pressure. At the point where the wastegate reaches its full closed position, the preselected manifold pressure will start to drop and this is considered critical altitude.

CHEROKEE ARROW III SERVICE MANUAL

8-23. REMOVAL OF TURBOCHARGER.

- a. Remove the upper cowling. (Refer to Paragraph 8-5.)
- b. Remove the turbocharger compressor and turbine assembly by the following procedure:
 1. Disconnect the oil supply and return lines from the center section of the turbo.
 2. Disconnect the air ducts from the compressor inlet and outlet and the exhaust system from the turbine inlet and outlet.
 3. Remove safety wire securing the turbine insulation blanket and remove blanket.
 4. Remove the bolts that attach the turbocharger to the mounting bracket and remove the turbocharger assembly.

WARNING

Comply with instructions of latest revision of Piper Service Bulletin No. 844.

NOTE

Piper considers service bulletins of utmost importance and compliance mandatory.

8-24. INSTALLATION OF TURBOCHARGER.

- a. Position turbocharger assembly on the mounting bracket and secure with attaching hardware.
- b. Align exhaust system manifold turbo inlet and the turbine inlet and secure with clamp temporarily.

NOTE

The turbocharger is properly installed with the large diameter center clamp loose to allow rotation of the turbine housing during installation for proper alignment with the exhaust system inlet connection. Tighten clamp after alignment.

When tightening any of the three V-band clamps, it is necessary to tap the clamp all around its circumference to ensure proper seating. Do not rely on tightening alone for proper clamp seating.

CHEROKEE ARROW III SERVICE MANUAL

- d. Place turbine housing insulation blanket in proper position and safety blanket to turbocharger attaching hardware.
- e. Position the exhaust tailpipe and exhaust bypass screw to the turbine outlet, aligning the tailpipe with the hole cut out in the lower cowl provided for it.

NOTE

Check the position of the exhaust bypass adjustment screw. If 8 minimum, 9 maximum threads are showing, below jam nut no adjustment is required. (See Figure 8-36).

- f. Tighten both turbine housing inlet clamps. (Refer to above note on tightening V-band clamps).
- g. Position the engine induction tube to turbocharger compressor outlet connector and the induction air inlet tube to the turbocharger compressor inlet connector in their proper locations and tighten the clamps.
- h. Connect the oil supply and return lines to the turbocharger center housing. Connect the oil pressure cockpit gauge line if it was previously disconnected.
- i. Perform engine ground run-up and check for normal engine functioning, excessive exhaust manifold leakage and oil leaks. Repair as necessary.
- j. Install the upper cowling.

8-25. ADJUSTMENT OF TURBOCHARGER. (Refer to Paragraph 8-61, Step b)

NOTE

A complete inspection of the power plant system should be performed before any turbo adjustments are made.

8-26. OVERBOOST VALVE.

8-27. REMOVAL OF OVERBOOST VALVE.

- a. Remove the four self-locking nuts, plain washers and bolts.
- b. Lift the overboost valve assembly from the induction tube.
- c. Remove the O-ring from the seating surface of the overboost mounting flange on the induction tube.

8-28. INSTALLATION OF OVERBOOST VALVE.

- a. Install a new O-ring on the overboost mounting flange of the induction tube.
- b. Position the overboost valve assembly on the mounting flange with the holes in the valve aligning with the holes in the flange.
- c. Install the four bolts and secure with plain washers and self-locking nuts.

8-29. INDUCTION SYSTEM AIR FILTER.

8-30. REMOVAL OF AIR FILTER. (Refer to Figure 8-8.)

- a. Remove the upper cowl.
- b. Release the stud fasteners; remove the filter cover and withdraw the filter element.

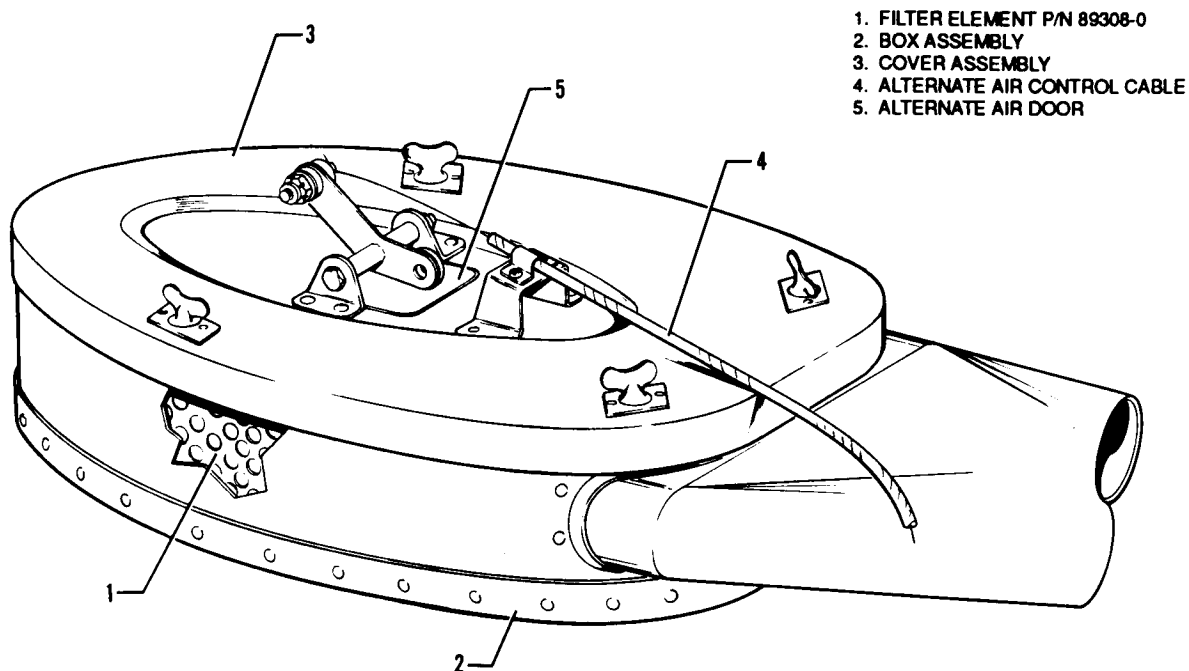

1. FILTER ELEMENT P/N 89308-0
2. BOX ASSEMBLY
3. COVER ASSEMBLY
4. ALTERNATE AIR CONTROL CABLE
5. ALTERNATE AIR DOOR

Figure 8-8. Induction System Installation

8-31. CLEANING INDUCTION AIR FILTER. The air filter element should be cleaned as often as it becomes dirty, everyday under severe dust conditions. The filter element should be replaced if any holes or tears exist. When cleaning the filter, it is a good practice to clean the filter box assembly with a clean cloth dampened with clean solvent.

CAUTION

Do not allow foreign materials to drop into or otherwise enter the filter box assembly outlet duct to the turbocharger. Failure to take necessary precaution could cause failure of the turbocharger.

- a. To clean the filter, rap gently on a hard surface to remove embedded debris. Be careful not to damage the sealing ends.

CAUTION

Never wash the filter element in any liquid or soak it in oil. Never attempt to blow off dirt with compressed air.

CHEROKEE ARROW III SERVICE MANUAL

8-32. INSTALLATION OF AIR FILTER. (Refer to Figure 8-8.)

- a. Properly position the filter element in the box assembly and secure the cover assembly with the stud fasteners.

NOTE

Check filter element for proper position by ensuring that the slightly raised section in the bottom of the box assembly is completely inside the filter element inner ring. After the cover assembly has been installed, open the alternate air door manually by depressing the door to ensure that no interference exist between the alternate air door and the filter element.

8-33. ALTERNATE AIR DOOR. The alternate air door is located in the alternate air box to provide a source of air to the engine should there be an air stoppage through the filter system. The following should be checked during inspection:

- a. Check that air door seals are tight and the hinge and torsion spring are secure.
- b. Adjust the control cable to position the roller on the arm assembly clear of the door in the closed position. Check that when the cockpit control is in the closed position the door is properly seated in the closed position.
- c. Actuate the door by operating the control lever in the cockpit to determine that it is not sticking or binding.
- d. Check the cockpit control cable for free travel.

8-34. IGNITION SYSTEM.

8-35. MAGNETOS.

CAUTION

Ascertain that the primary circuits of both magnetos are grounded before working on the engine.

NOTE

The magneto service instructions in this manual cover minor repairs and timing. For further repairs and adjustments of the magnetos, it is recommended that the magneto manufacturer's service instructions be followed. (Refer to Continental Service Bulletin No. M78-8 for additional ignition maintenance.)

8-36. INSPECTION OF MAGNETOS.

- a. After the first 25 hour and 50 hour periods, and periodically thereafter, the contact assemblies should be checked. Examine the points for excessive wear or burning. Points which have deep pits or excessively burned areas should be discarded. Examine the cam follower felt for proper lubrication. If necessary, points can be cleaned by using any hard finished paper. Clean breaker compartment with dry cloth.
- b. If engine operating troubles develop which appear to be caused by the ignition system, it is advisable to check the spark plugs and wiring first before working on the magnetos.

CHEROKEE ARROW III SERVICE MANUAL

WARNING

When servicing or inspecting vendor equipment installed in Piper Aircraft, it is the user's responsibility to refer to the applicable vendor publication.

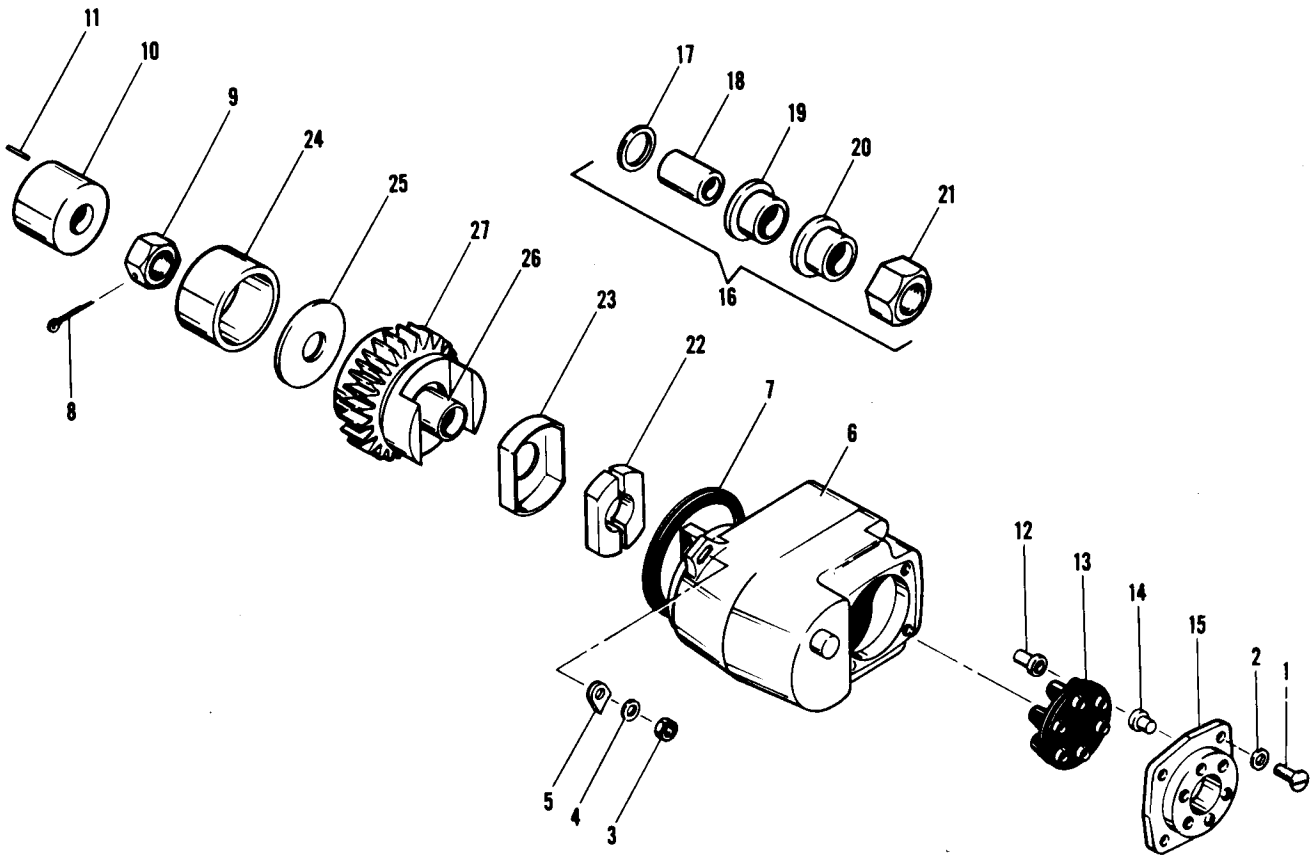

1. SCREW
2. LOCK WASHER
3. NUT
4. LOCK WASHER
5. HOLD DOWN WASHER
6. MAGNETO
7. GASKET
8. COTTER PIN
9. NUT
10. GEAR SUPPORT SHAFT
11. PIN
12. IGNITION CABLE EYELET
13. DISTRIBUTOR CABLE GROMMET
14. IGNITION CABLE FERRULE

15. DISTRIBUTOR CABLE PLATE
16. GROUND TERMINAL KIT
17. WASHER
18. INSULATING SLEEVE
19. INNER FERRULE
20. OUTER FERRULE
21. COUPLING NUT
22. COUPLING BUSHINGS
23. RETAINER
24. NEEDLE BEARING
25. WASHER
26. PILOT SLEEVE BUSHING
27. MAGNETO DRIVE GEAR

Figure 8-8a. Magneto Assembly

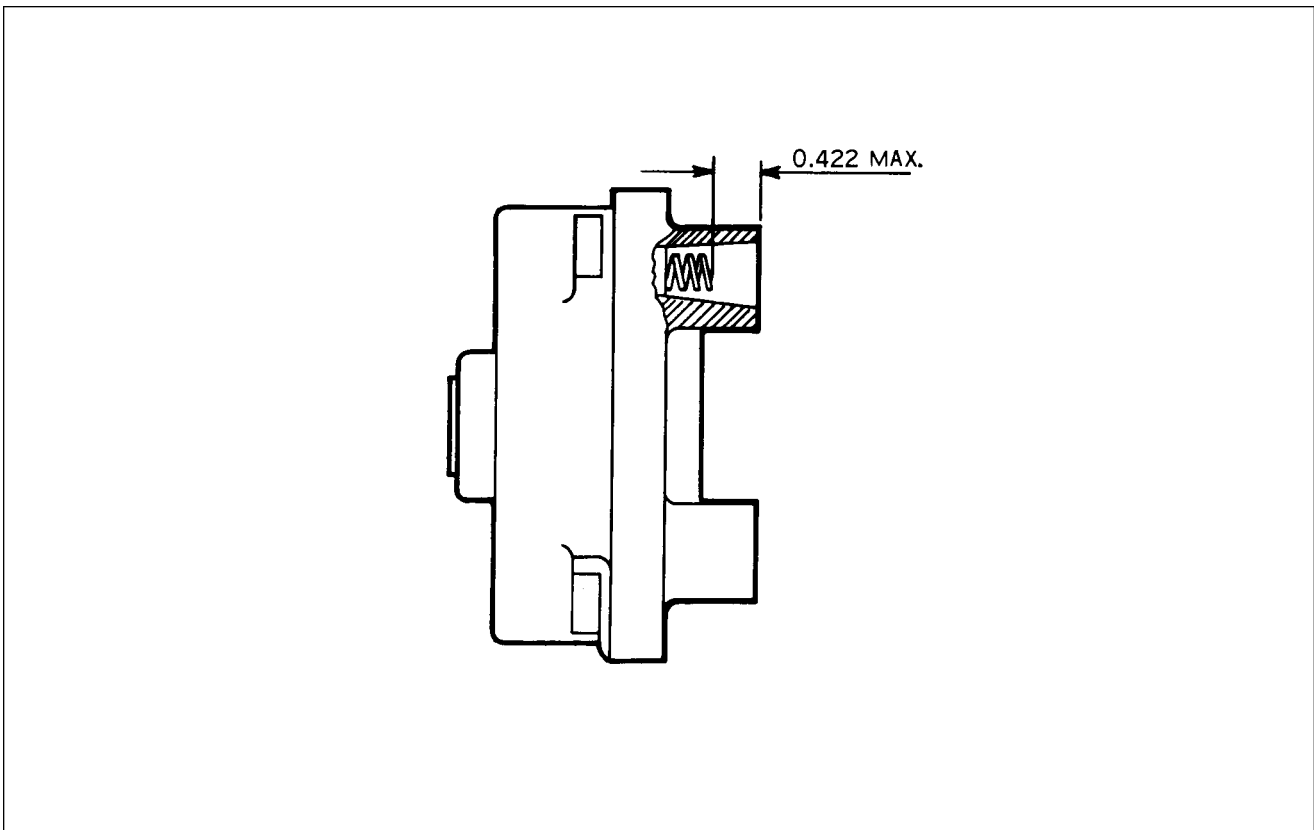
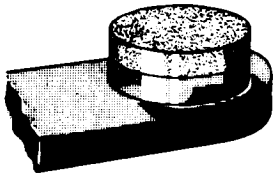

Figure 8-9. Contact Spring Inspection.

- c. Should the trouble appear definitely associated with the magneto, the most effective measure is to install a replacement magneto which is known to be in satisfactory condition and send the suspected unit to the overhaul shop for test and repair.
- d. Should this not be possible, a visual inspection may disclose the source of trouble. Remove the harness outlet plate from the magneto. Inspect for the presence of moisture and foreign matter on the rubber grommet and high tension outlet side of the distributor block. Check height of block contact springs. The top of the spring must not be more than 0.422 of an inch below the top of the tower as shown in Figure 8-9. If the springs are broken or corroded, replace them.
- e. Inspect the distributor block for cracks or burned areas. The wax coating on the block should not be removed. Do not use solvents.
- f. Check for excess oil in the breaker compartment. If present, it may mean a bad oil seal or oil seal bushing at the drive end. Check the magneto manufacturer's overhaul procedure.
- g. Remove the breaker cover and harness securing screws and nuts and separate cover from magneto housing. Check contact assemblies to see that cam follower is securely riveted to its spring. Examine the contact points for excessive wear or burning. Figure 8-10 shows how the average contact point will look when surfaces are separated for inspection. Desired contact surfaces have a dull gray, sandblasted (almost rough) or frosted appearance over the area where electrical contact is made. This means that points are worn in and mated to each other, thereby providing the best possible electrical contact and highest efficiency of performance.
- h. Minor irregularities or roughness of point surfaces are not harmful (refer to Figure 8-10, center), neither are small pits or mounds, if not too pronounced. If there is a possibility of pit becoming deep enough to penetrate pad, Figure 8-10, right, reject contact assembly.

CHEROKEE ARROW III SERVICE MANUAL

NORMAL POINT IS SMOOTH AND FLAT. SURFACE HAS DULL GRAY "SANDBLASTED" APPEARANCE



MINOR IRREGULARITIES - SMOOTH ROLLING HILLS AND DALES WITHOUT ANY DEEP PITS OR HIGH PEAKS. THIS IS A NORMAL CONDITION OF POINT WEAR.

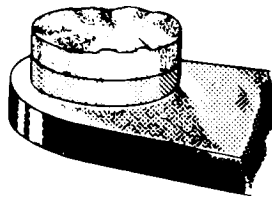

WELL DEFINED MOUND EXTENDING NOTICEABLY ABOVE SURROUNDING SURFACE. REJECT POINTS.

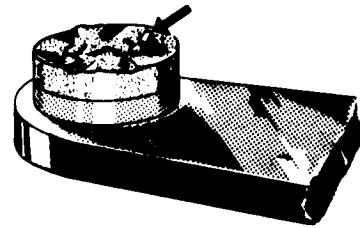

Figure 8-10. Contact Points.

NOTE

No attempt should be made to stone or dress contact points. Should contact assembly have bad points or show excessive wear, the complete contact assembly should be replaced.

- i. Check the condition of the cam follower felt. Squeeze felt tightly between thumb and forefinger. If fingers are not moistened with oil, re-oil using 2 or 3 drops of Bendix 10-86527 lubricant. Allow approximately 30 minutes for felt to absorb the oil. Blot off the excess with a clean cloth. Too much oil may foul contact points and cause excessive burning.
- j. Inspect the felt washer in the distributor block for oil content. If the felt is dry, inspect the bronze bushing for wear. (Refer to manufacturer's overhaul instruction.) Oil felt washer with Bendix Distributor Block Lubricant Part No. 10-391200. Blot excess oil from washer until flat surfaces take on a "frosted" appearance and seat washer in its recess in block.
- k. Check the capacitor mounting bracket for cracks or looseness. Using the Bendix 11-1767-1, -2 or -3 Condenser Tester or equivalent, check capacitor for capacitance, series resistance and leakage. Capacitance shall be at least 0.30 microfarads. Series resistance should not be over 1 ohm at 500 kc.
- l. Inspect coil leads for damaged insulation's and terminals for tightness and soldered connection.
- m. Inspect impulse coupling parts for excessive wear. Particularly check clearance between cam and flyweights of the cam assembly. Measure the clearance between the cam flyweights using the shank of a new No. 18 drill (0.169 inch diameter). If the drill will fit between cam and flyweight as shown in Figure 8-11, the cam assembly must be replaced. Check clearance between both flyweights and the cam of each cam assembly.

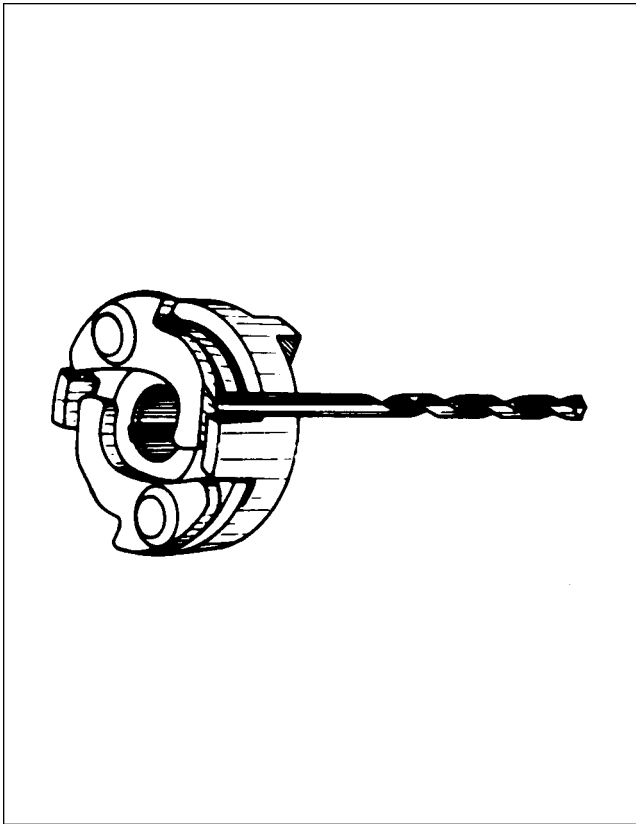

Figure 8-11. Impulse Coupling

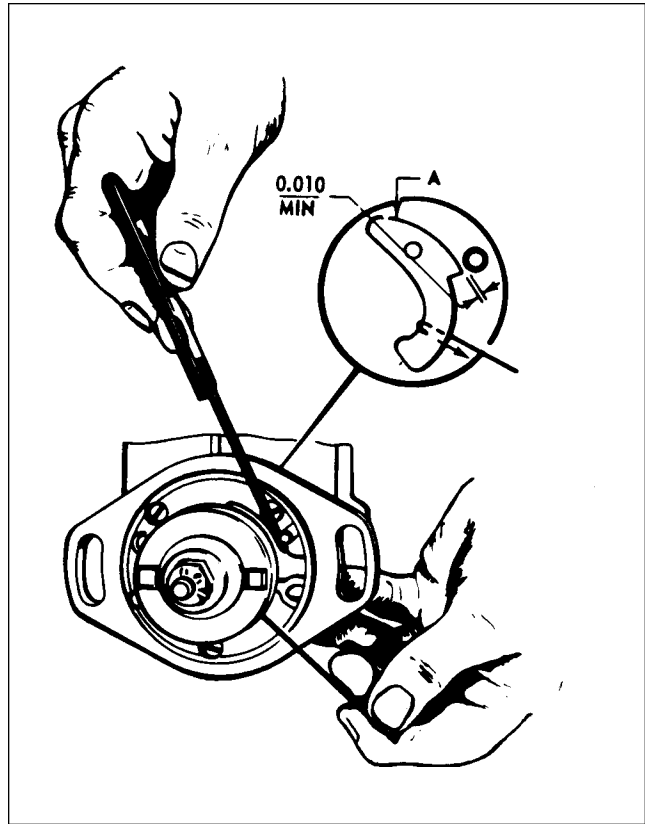

Figure 8-12. Flyweight Clearance of Impulse Coupling

- n. Check the clearance between each flyweight and each stop pin as follows:
 1. Bend the end of a stiff piece of wire into a right angle 0.125 inch long (maximum).
 2. Hold magneto as shown in Figure 8-12. Pull heel of flyweight outward with the hooked wire and make certain that feeler gauge of 0.010 inch minimum thickness will pass between stop pin and the highest point of the flyweight.

NOTE

A true and accurate check of the clearance between flyweight and stop pin can only be obtained by pulling the flyweight outward as described above. Do not attempt the check by pushing in on flyweight at point "A."

- o. Check internal timing and reinstall and time magneto to engine.

8-37. REMOVAL OF MAGNETO.

- a. Remove the engine cowl.
- b. Disconnect the "P" lead from the magneto.
- c. Remove the harness outlet plate from the magneto by removing the four attaching screws.
- d. Remove the two nuts and washers securing the magneto to the engine accessory housing.
- e. Pull the magneto from the engine.

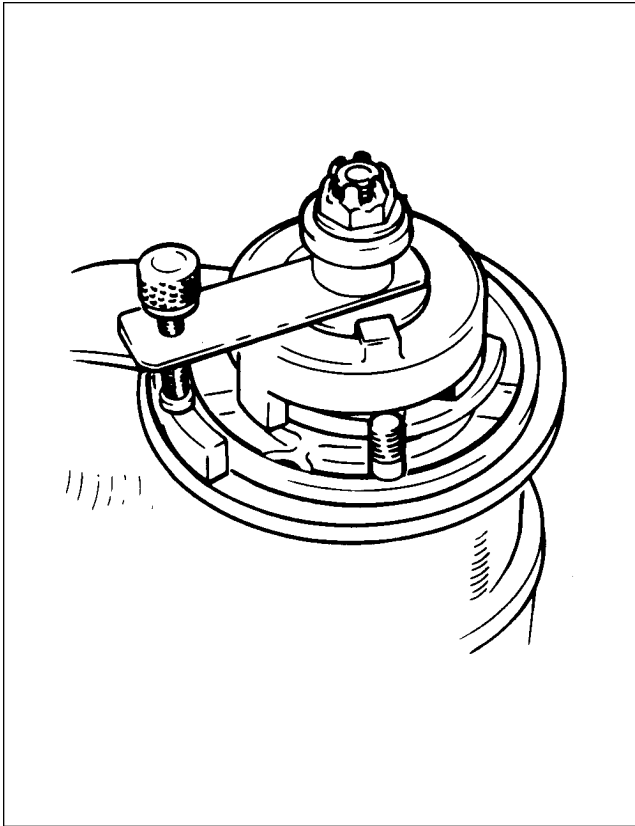

Figure 8-13. Rotor Holding Tool Installed

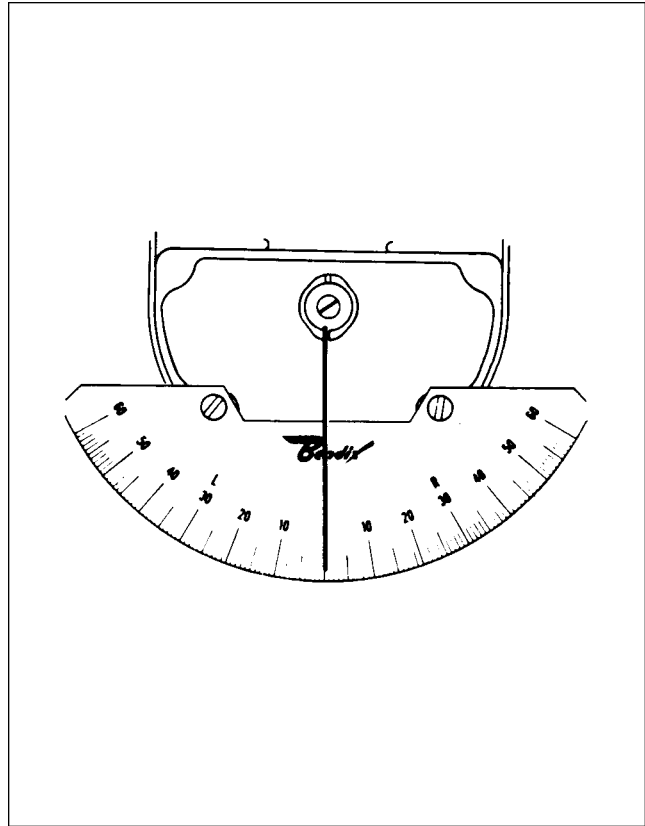

Figure 8-14. Timing Kit Installed

8-38. MAGNETO TIMING PROCEDURE (INTERNAL TIMING). When installing or adjusting breaker points and before timing the magneto to the engine, it is important that the internal timing of the magneto be correct. The recommended method of checking the internal timing of the magneto is to use the Bendix 11-8150 Timing Kit using the procedure described in sub-paragraph a. However, if a timing kit is not available, the cast in timing marks in the breaker housing and a fabricated pointer may be used as described in sub-paragraph b.

- a. Check the internal timing with the Bendix 11-8150 Timing Kit using the following procedure:
 1. Remove the magneto from the engine and remove the contact point cover.
 2. Loosen the nut securing the drive plate to the magneto shaft sufficiently in order to install the Bendix 11-8465 Rotor Holding Tool under the nut and flat washer as shown in Figure 8-13. Tighten the nut enough to hold the tool securely.
 3. Install the Bendix 11-8147 Plate Assembly to the breaker compartment of the magneto as shown in Figure 8-14.
 4. Remove the timing inspection plug from the top of the magneto and turn the rotating magnet in the direction of normal rotation until the painted chamfered tooth on the distributor gear is approximately in the center of the inspection window. Then turn it back until rotating magnet locates in its neutral position. Tighten adjustment knob of 11-8465 Rotor Holding Tool, holding the rotating magnet in the neutral position.

CAUTION

Tighten adjusting knob of rotor holding tool only enough to hold magnet shaft firmly. Do not overtighten.

CHEROKEE ARROW III SERVICE MANUAL

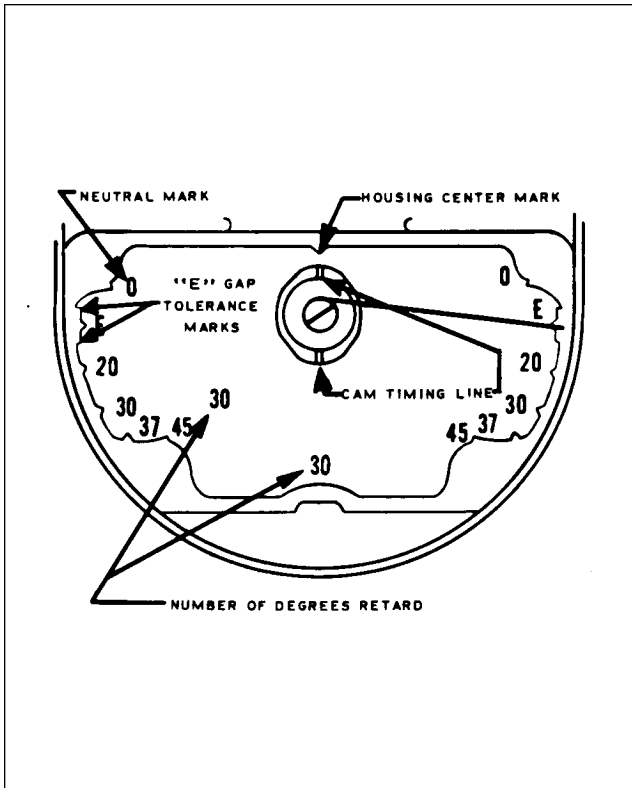

Figure 8-15. Cast-in Timing Marks

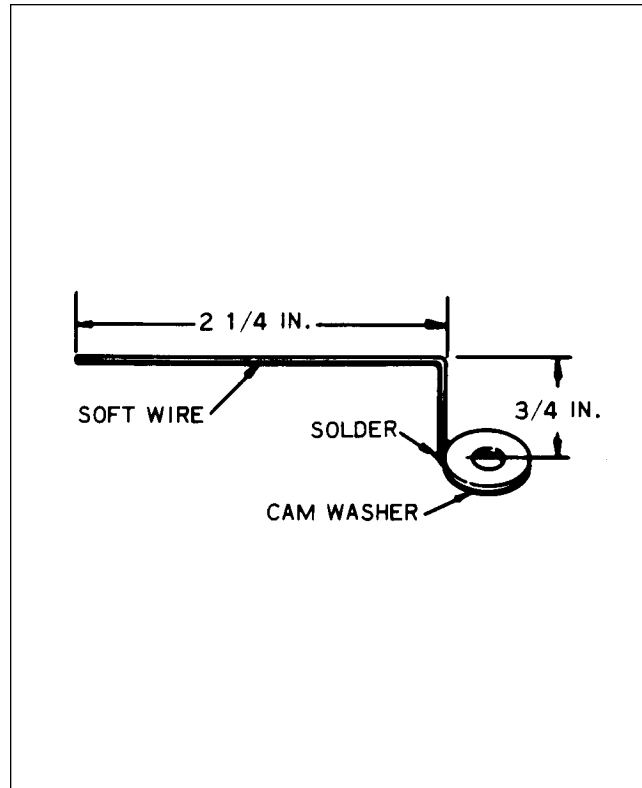

Figure 8-16. Fabricated Pointer

5. Install the Bendix 11-8149 Pointer Assembly on the cam screw and align pointer with the zero degree mark on the timing plate.
 6. Loosen adjusting knob of rotor holding tool and turn rotating magnet in normal direction of rotation until pointer indexes with the respective 10° mark ("E" gap). Tighten adjustment knob of rotor holding tool.
 7. With the Bendix 11-9110 Timing Light or equivalent, adjust main breaker contacts to just open at this position. Loosen holding tool and turn rotating magnet until breaker cam follower is on the high point of the cam lobe. Tighten holding tool and measure contact clearance. It must be 0.018 ± 0.006 . If not, readjust breaker and recheck to be sure that contacts will open within "E" gap tolerance $\pm 4^\circ$. Replace breaker assembly if "E" gap tolerances and contact clearance cannot be obtained.
 8. After timing is complete, tighten breaker securing screws to 20 to 25 inch-pounds and recheck settings. Remove timing kit parts.
- b. The internal timing can be checked without a timing kit using the cast in marks in the breaker compartment. These marks indicate "E" gap and limits (refer to Figure 8-15). The point in the center of the "E" gap boss indicates the exact "E" gap position. The width of the boss on either side of the point is the allowable tolerance of $\pm 4^\circ$. In addition to these marks, the cam has an indented line across its end. When the indented line is aligned with the mark at the top of the breaker housing, the rotating magnet is in its "E" gap position. Check the timing using the following procedure:
1. Install the Rotor Holding Tool 11-8465 under the drive shaft nut and washer as shown in Figure 8-13.

NOTE

The rotor holding tool facilitates the timing procedure. However, it is possible to manually hold the shaft at the specified angle when setting the breakers.

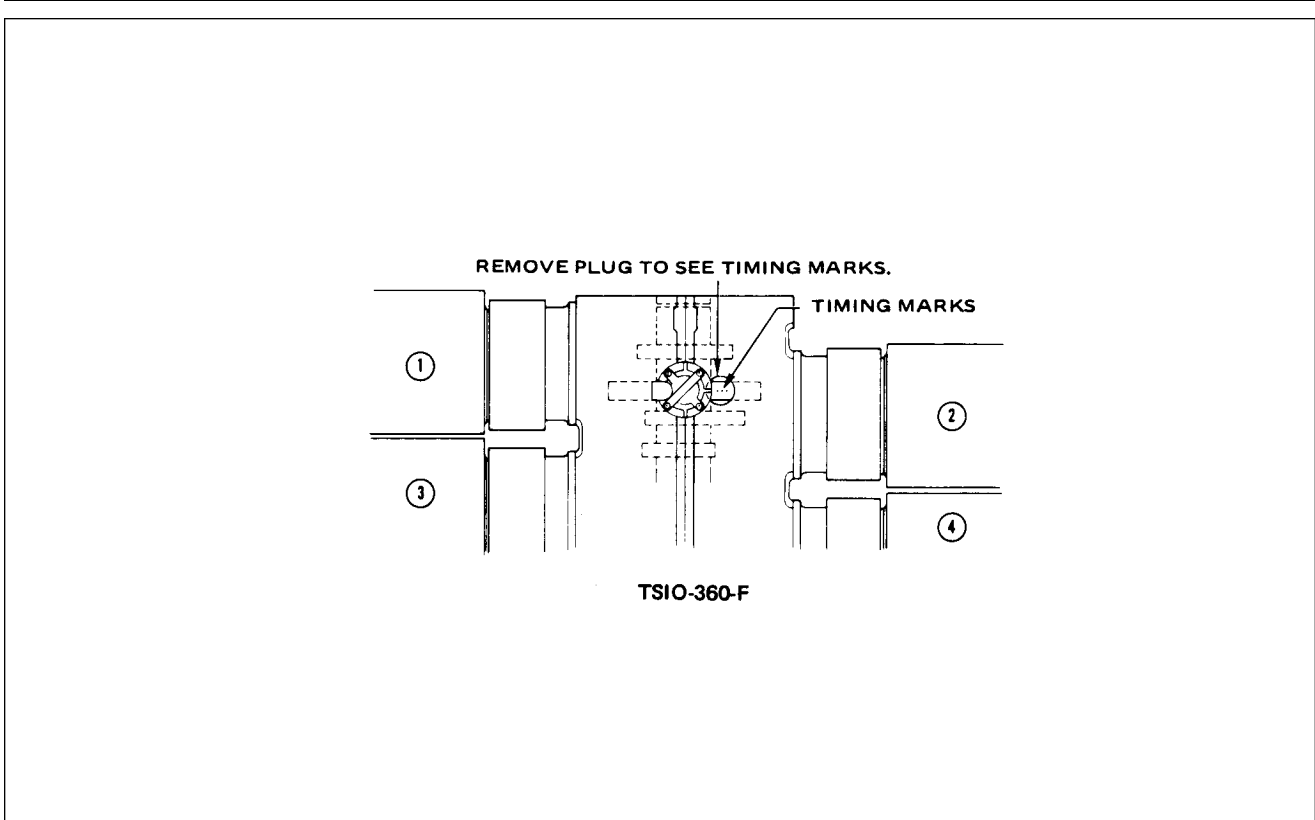

Figure 8- 17. Engine Timing Marks

2. Turn rotating magnet in direction of rotation until painted chamfered tooth of distributor gear is just becoming visible in timing window. Continue turning rotating magnet until line on end of cam is aligned with mark at top of breaker housing. (Refer to Figure 8-15.) Tighten adjusting knob of the holding tool to hold rotating magnet.
3. Fabricate a pointer as shown in Figure 8-16 and install the pointer under the cam screw so the pointer indexes in the center of "E" gap position.
4. Connect the 11 -9110 Timing Light or equivalent across breaker assembly. Adjust breaker contacts to just open at this position.
5. Loosen holding tool and turn rotating magnet until cam follower is on high point of cam lobe. Tighten holding tool and measure contact clearance. It must be 0.018 ± 0.006 . If necessary, readjust breaker. Check to be sure contacts open within "E" gap tolerance. Replace breaker assembly if "E" gap tolerance and contact clearance cannot be obtained. Tighten breaker screws to 20 to 25 inch-pounds and recheck breaker settings.

8-39. MAGNETO INSTALLATION AND TIMING PROCEDURE (MAGNETO TO ENGINE). (Refer to Figure 8-17.)

- a. The timing marks are on the outer edge of the crankshaft counterweight blade between No. 2 and No. 4 cylinders. The inspection plug between No. 2 and No. 4 cylinders on the left top side of the crankcase must be removed to view the marks on the crankshaft.
 1. Plug one spark plug hole of the No. 1 cylinder and place a thumb over the other plug hole. Have a second person stand in front of the engine and turn the crankshaft in a counterclockwise direction until pressure is felt on the thumb. No. 1 piston is coming up on the compression stroke.
 2. Remove the inspection hole plug and turn the crankshaft counterclockwise until the 20 degree BTC mark appears in the center of the inspection hole. A timing device as described in Service Bulletin M68-2, Rev. 1 may also be used.

CHEROKEE ARROW III SERVICE MANUAL

3. Remove the inspection hole plug from the magneto. Turn the magneto coupling until the painted chamfered tooth on the distributor gear is approximately centered in the inspection hole. Hold the magneto in its approximate installed position. Note carefully the position of the coupling drive lugs.
4. Lubricate the gear support shaft with clean lubricating oil and install the drive gear assembly so the slots of the coupling bushings will be in the approximate position for aligning with the drive coupling lugs on the magneto.
5. Insert the retainer into the gear hub slot. Apply a film of Lubriplate grease to each of the new rubber bushings and insert the bushings into the retainers, rounded long edges first.
6. Place a new gasket on the magneto flange. Install the magneto carefully so the drive coupling lugs mate with the slots of the drive bushings. Install and snug down the two sets of attaching screws. Do not tighten at this time.
7. Breaker point opening may be checked by use of a suitable timing light. Tap the magneto case with a non-marring hammer, counterclockwise (from the rear) to make certain the points are closed. After the timing light indicates that the points are closed, tap the magneto lightly clockwise until the points are open. Tighten the magneto attaching nuts.
8. Check timing by backing up crankshaft approximately 5 degrees and tapping gently forward until the timing light indicates opening of breaker points. If timing is correct, the 20 degree mark (midway between the 16 and 24 stamped on the crankshaft) will appear in the center of the inspection hole. The crankshaft has punch marks in 2 degree increments with 16 and 24 at each end. Tighten the magneto attachment nuts and replace the plug in the inspection hole on top of the engine.

8-40. HARNESS ASSEMBLY.

8-41. INSPECTION OF HARNESS.

- a. Check the lead assemblies for nicks, cuts, mutilated braiding, badly worn section or any other evidence of physical damage. Inspect the spark plug sleeves for chafing or tears and damaged or stripped threads on coupling nuts. Check the compression spring to see if it is broken or distorted. Inspect the grommet for tears. Check all the mounting brackets and clamps to see that they are secure and not cracked.
- b. Should a harness problem be suspected, integrity of the harness wiring may be checked using an ohmmeter, buzzer, or other suitable device such as the Bendix/ECD High Tension Lead Tester Kits, P/N 11-8950 or 11-8950-1; check each lead for continuity. If continuity does not exist, harness wire is broken and must be replaced.
- c. If an insulation failure is suspected, the condition of the insulation may be determined using the Bendix 11-8950 and the 11-8950-1 High Tension Lead Tester Kits manufactured by the Electrical Components Division, The Bendix Corporation, Sidney, New York.
- d. Test Unit Preparation:
 1. Install two "C" cells in the battery holder in accordance with correct position.
 2. Check that red and black leads are open-circuited.
 3. Depress PRESS-TO-TEST push-button switch.
 4. Insure INDICATOR lamp flashes and GAP fires intermittently as long as PRESS-TO-TEST switch is depressed.
 5. Interconnect both red and black high voltage leads and again depress PRESS-TO-TEST switch. INDICATOR lamp only should flash. GAP does not fire.
 6. Disconnect black and red leads.
- e. Insulation Test:
 1. Attach clip of red high voltage test lead to ignition harness lead terminal.
 2. Attach black test lead clip to lead ferrule.

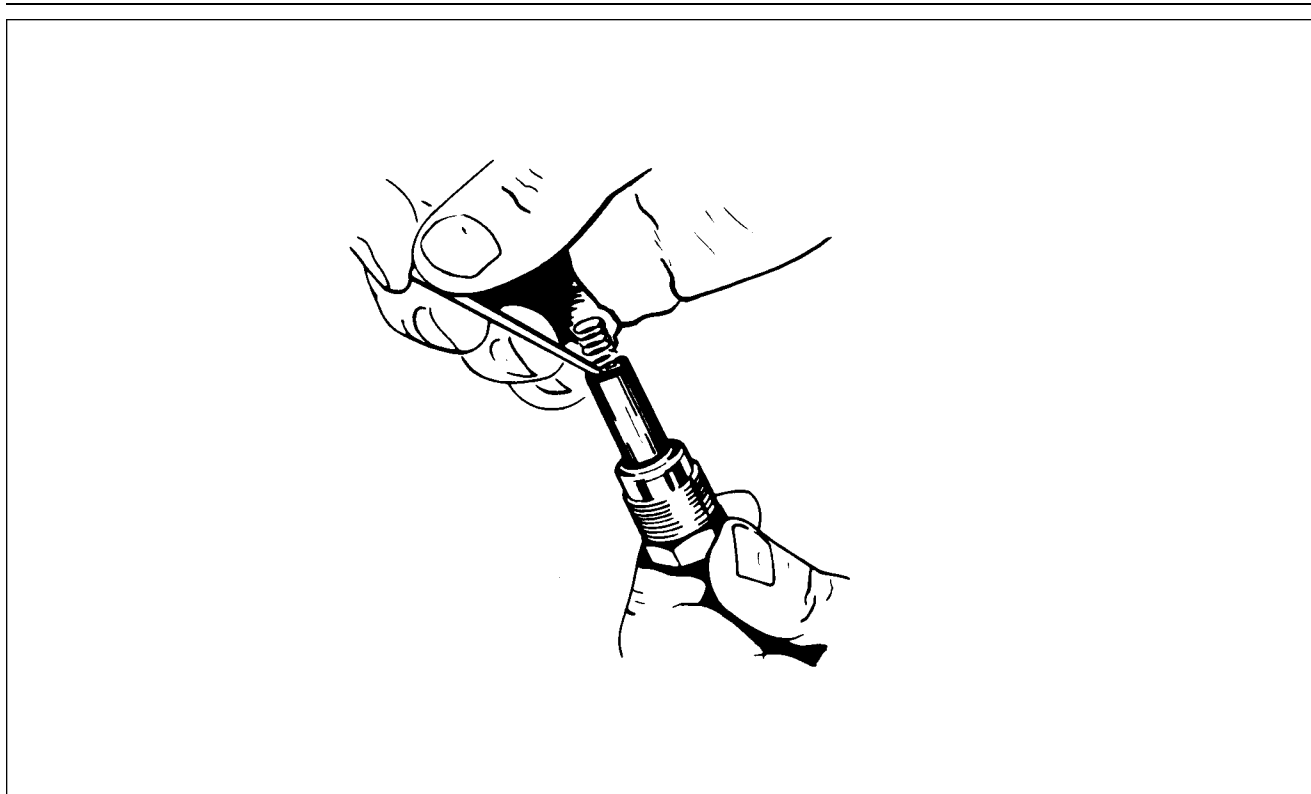

Figure 8-18. Removing Spring From Lead Assembly

3. Depress PRESS-TO-TEST push-button switch.
4. Observe that INDICATOR lamp flashes and GAP fires intermittently as long as PRESS-TO-TEST switch is held depressed.
5. Whenever INDICATOR lamp flashes and gap fails to fire, lead under test is defective.
6. When testing leads which are installed on an engine, it may be found that distributed capacitance causes the tester to reject good leads if the tester and red test lead are allowed to lay in close physical contact with the engine parts. For best results, keep the tester and the red high voltage lead well clear of the grounded metal parts of the engine.
7. On some engines, leakage through the magneto distributor to the magneto coil may occur if the distributor finger electrode is lined up with the lead under test. If this occurs, the tester will indicate a rejection. Before final rejection of a lead which has one end connected to the magneto, turn the engine slightly and repeat test to confirm the reading.
- f. A second acceptable method for performing an insulation check is with a high voltage, direct current tester such as the TAKK Model 86 or 86A or an equivalent direct current tester capable of delivering a test potential of 10,000 volts. Connect ground lead of high voltage tester to outer shielding braid of a single lead. Connect plug terminal. Turn tester ON and apply 10,000 volts. The insulation resistance should be 100 megohms minimum. Proceed to check other leads of harness in the same manner.

8-42. REMOVAL OF HARNESS.

- a. Disconnect the clamps that secure the wires to the engine and accessories.
- b. Loosen the coupling nuts at the spark plugs and remove the insulators from the spark plug barrel well. Use caution when withdrawing the insulator so that the insulator spring will not be damaged.
- c. Place a guard over the harness insulators.
- d. Remove the harness assembly terminal plate from the magneto.
- e. Remove the harness from the airplane.

CHEROKEE ARROW III SERVICE MANUAL

8-43. MAINTENANCE OF HARNESS.

- a. To replace contact springs, spring retainer assemblies or insulating sleeves, proceed as follows:
 1. Using a Bendix 11-7073 Needle or a mechanical pencil with the lead retracted, hook the end of the contact spring as shown in Figure 8-18.
 2. Using the needle or pencil, unscrew the spring.
 3. Slide the insulating sleeve and spring retainer assembly off the end of the lead assembly.
 4. Replace the defective component and reassemble as follows:
 - (a) Fabricate a tool as shown in Figure 8-19 for installing the insulating sleeves over the cable terminals.
 - (b) Push the tool through insulating sleeve and spring retainer assembly as shown in Figure 8-20. Screw the cable terminal into the tool.
 - (c) Work the insulating sleeve and spring retainer assembly into position over the cable and unscrew the tool. Install the contact spring on the cable terminal.

NOTE

It may be necessary to lubricate the cable and insulating sleeve with a thin film of Dow-Corning 200 (200,000 centi-stokes) or commercial grade alcohol to facilitate assembly.

- b. To replace one of the lead assemblies, proceed as follows:
 1. Remove the clamps and brackets from the applicable lead assembly. Cut the cable ties from the assembly and discard them.
 2. Cut off the condemned lead flush with the outer surface of the cable outlet plate.
 3. Grip the eyelet of the lead with a pair of pliers and pull the short length of conductor out of grommet and cable outlet plate.
 4. Using a 3 inch long, 0.270 of an inch diameter drift applied at outer surface of plate, drive out tapered ferrule and remaining pieces of insulation and shielding.
 5. To determine what length the new lead assembly should be cut to, proceed as follows:
 - (a) Measure the length of the condemned lead assembly. Move the coupling nut back on the lead assembly and measure from the outer end of the ferrule at the spark plug end. (Refer to Figure 8-21.)

NOTE

Spare part leads are supplied in various lengths. Use a lead which is longer than, but nearest to, the desired length.

6. Cut the lead assembly to the length determined in Step 5. Mark the ferrule on the spark plug end of the lead with a metal stamp, scribe or rubber stamp to correspond with the correct cylinder number.
7. Starting at the spark plug location, thread the new cable through the grommets and clamps as necessary for the correct routing of the cut end of the cable to the magneto location.
8. Remove the cable outlet plate from the magneto. Support the plate securely and using suitable cutting pliers, split and remove the eyelets from the leads adjacent to the lead being replaced. When splitting the eyelet, make certain that the wire strands are not cut. Removal of eyelets on adjacent leads will allow the grommet to be pulled away from the outlet plate to facilitate insertion of the new lead.
9. Assemble the lead to the cable outlet plate following the procedure in Steps 10 through 17.

CHEROKEE ARROW III SERVICE MANUAL

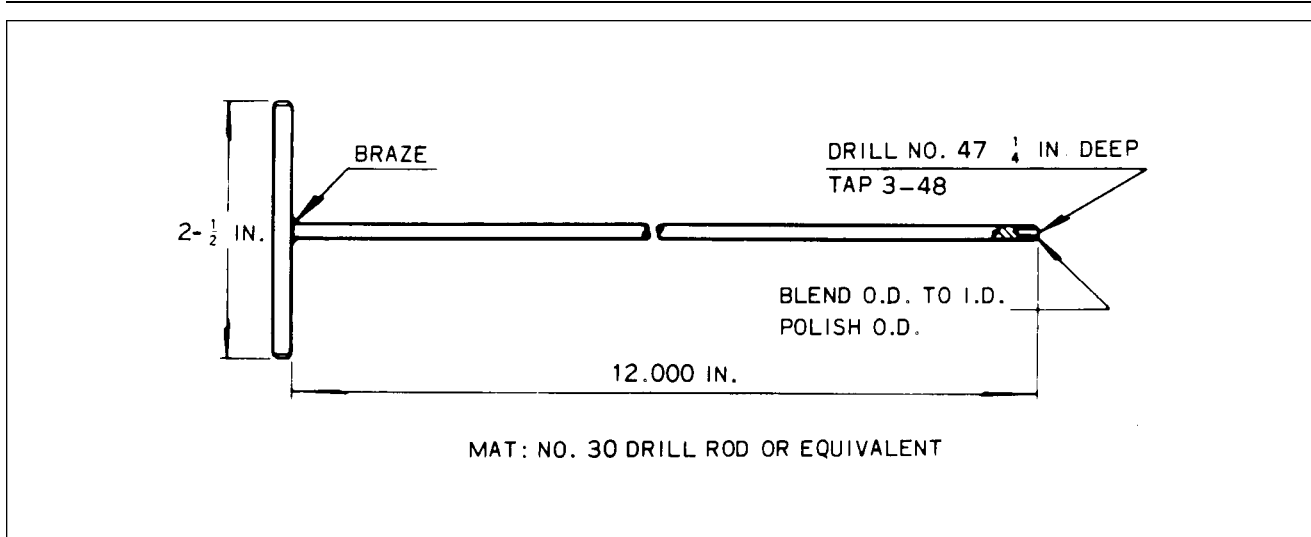

Figure 8-19. Assembly Tool

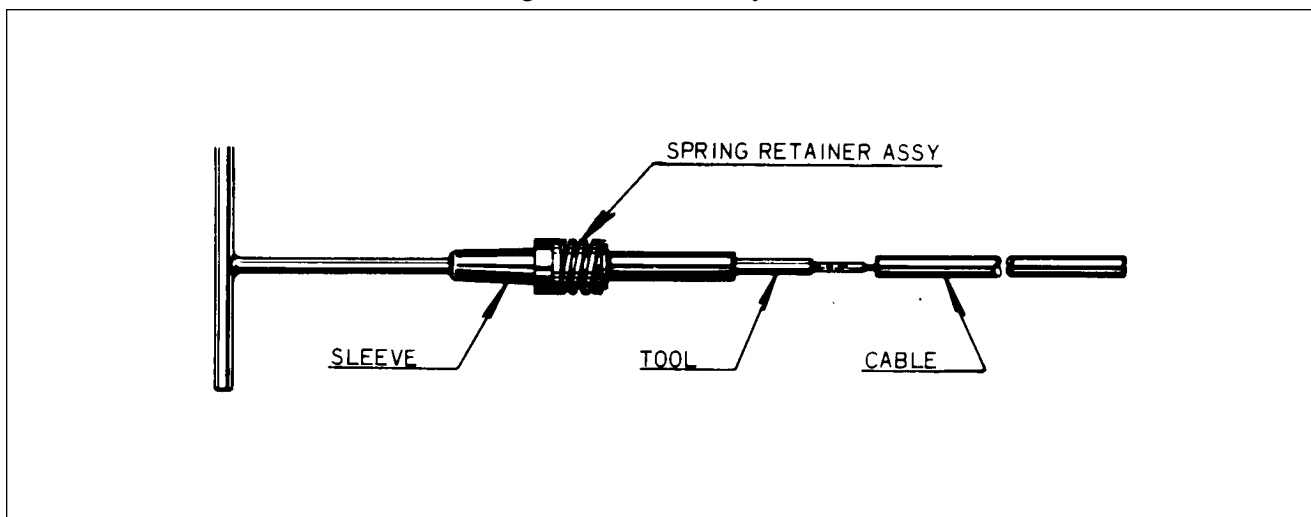

Figure 8-20. Assembly Tool Application

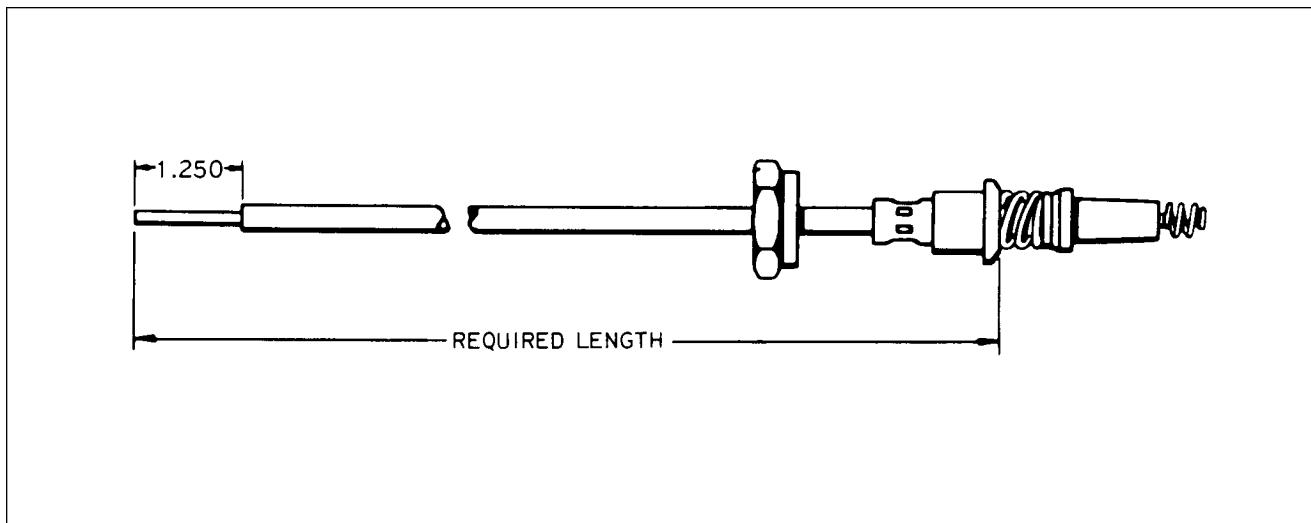

Figure 8-21. Measuring Lead Assembly Length

CAUTION

Insure before every cutting or stripping procedure that braid has not worked back on lead by grasping lead in one hand and sliding the other hand firmly along lead toward the outlet plate. If braid is improperly located on lead, the lead may be trimmed to the wrong length.

10. Pass the lead through the proper hole in outlet plate. Position the Bendix 11-9596 or equivalent Braid Cutting Backup Tube between the braided shielding and insulation to protect the insulation. Cut enough braid from the lead to have 1-1/4 inch of insulation extending from end of braid.

CAUTION

Be sure the cutting backup tube is completely under the point at which the cut is to be made to prevent cutting or nicking insulation.

11. Slide inner ferrule under the braid. The braid should cover approximately two-thirds of the ferrule taper. Remove the blue silicone coating from the end of the braid over ferrule by lightly scraping with a knife or wire brush.

CAUTION

When removing silicone coating, care should be taken not to damage the braided wire shielding.

12. Pull the lead assembly back through cable outlet plate until cleaned braid binds in the outlet well. Position the Bendix 11-7074 Ferrule Seating Tool (Figure 8-22) over the insulation and firmly seat the ferrule by tapping the seating tool with a hammer or by using an arbor press.
13. Measure 1/2 inch from tapered ferrule and strip remaining insulation from wire. (Refer to Figure 8-23.)
14. Insert Bendix 11-7073 Needle (Figure 8-24) through the small hole of the grommet and over the stripped end of the wire. (Refer to Figure 8-25.) Slide grommet down needle until it seats tightly against the tapered ferrule.
15. Cut the wire 3/8 inch from the top of the grommet outlet. (See Figure 8-26.) Double the wire over as shown in A of Figure 8-27. Slide the eyelet over the doubled wire until it is firmly seated in the recess of the grommet outlet.
16. Using a suitable crimping tool or equivalent, crimp the eyelet to the wire. Approximately 1/32 inch of wire should extend from the end of the eyelet after crimping. See B of Figure 8-27.

NOTE

If the crimping tool is not available, a satisfactory connection can be made by soldering with Kester Flux 709 or equivalent and a non-corrosive solder. After soldering, clean solder joints using denatured alcohol.

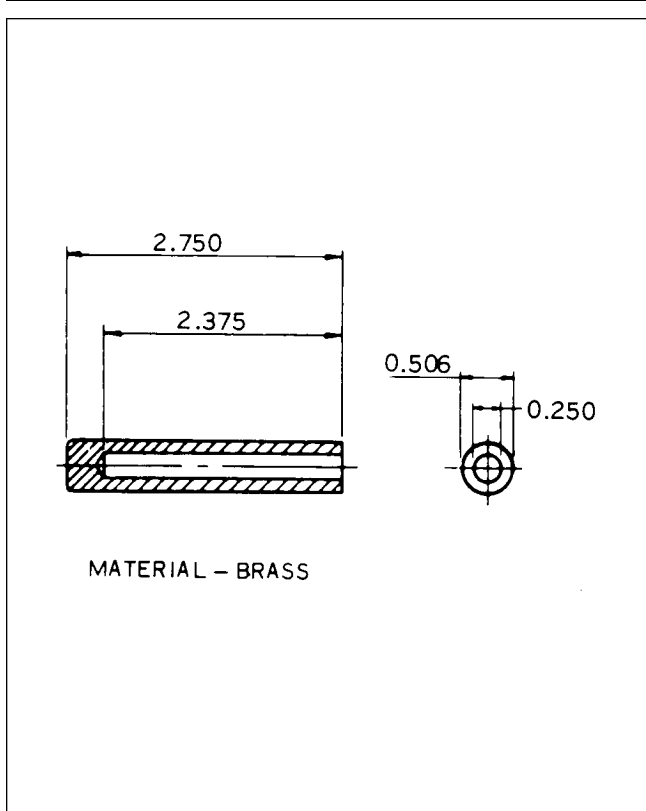

Figure 8-22. Ferrule Seating Tool

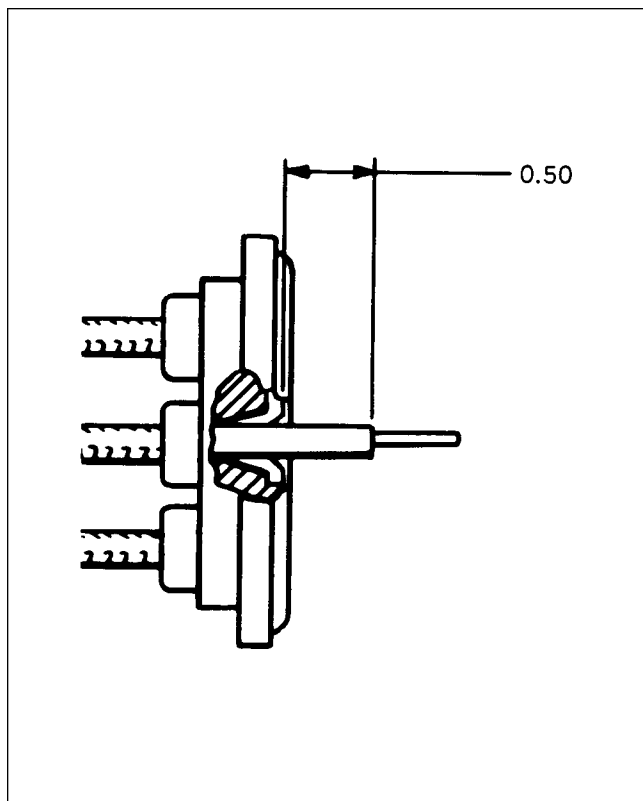

Figure 8-23. Measuring Wire From Top of Ferrule

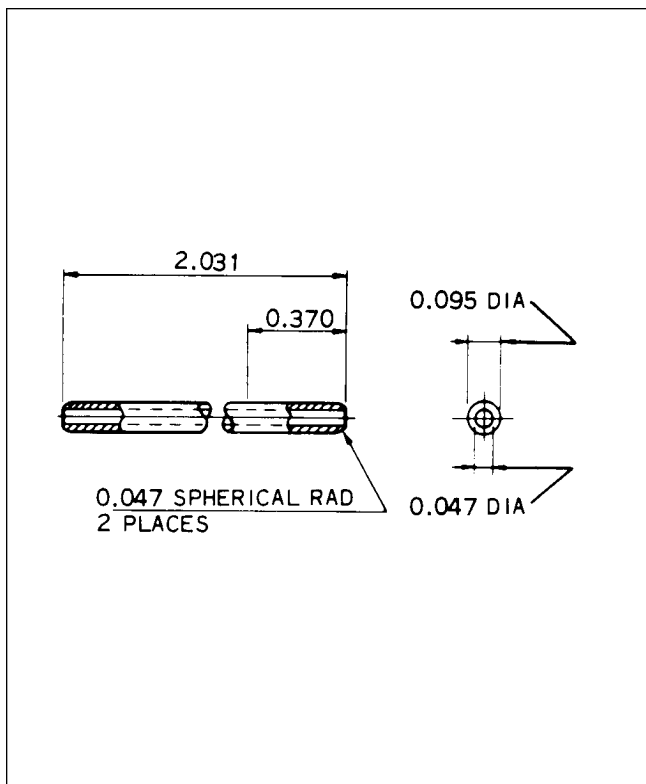

Figure 8-24. Needle

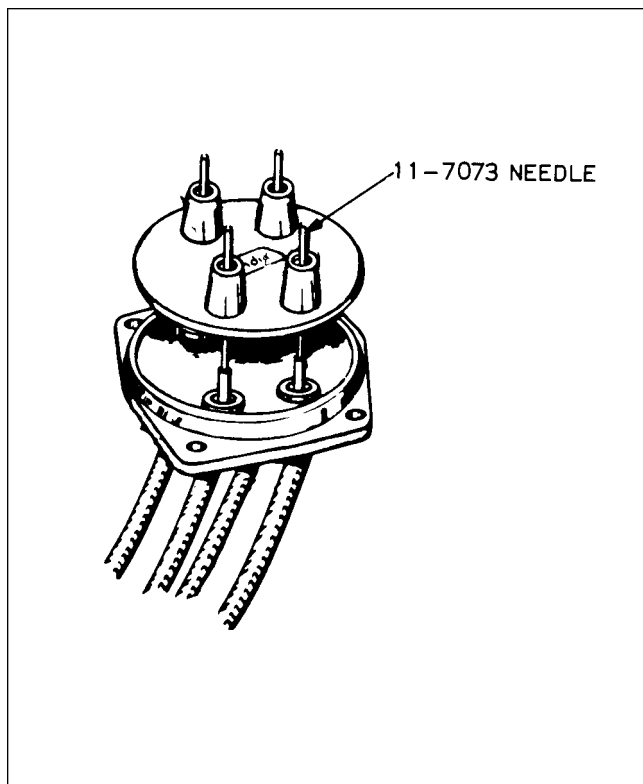

Figure 8-25. Installing Grommet Over Lead Assemblies

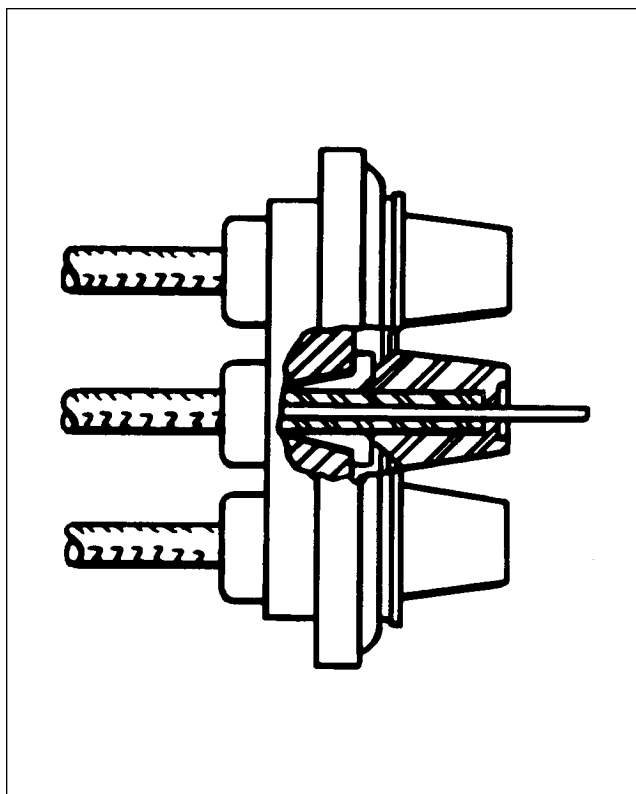

Figure 8-26. Lead Assembly Installed in Grommet

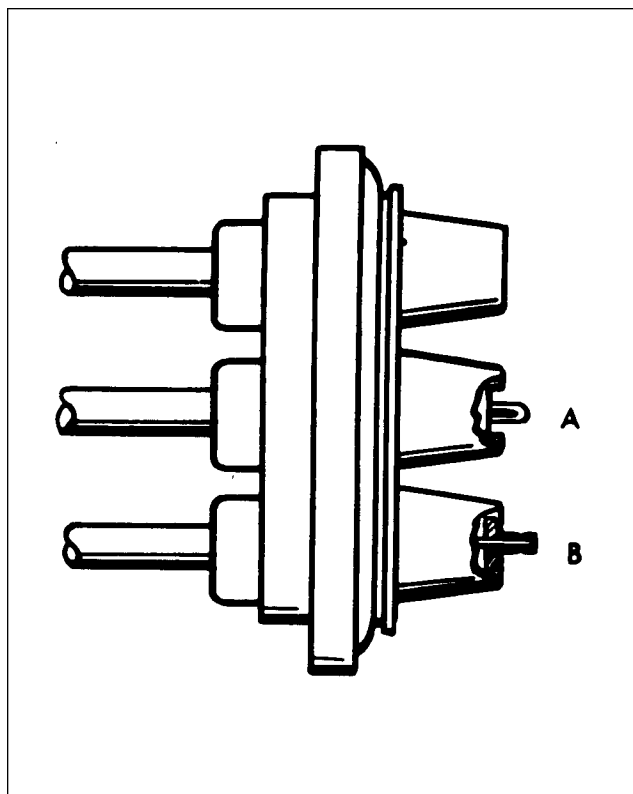

Figure 8-27. Wire Doubled Over For Installation of Eyelet

17. Install the clamps and cable ties, as necessary, to secure the lead to the engine.

CAUTION

Leads should be dressed away from hot spots, such as manifolds and sharp edges which cause chafing.

8-44. INSTALLATION OF HARNESS. Before installing the harness plate on the magneto, check the mating surfaces for cleanliness. Spray the entire face of the grommet with a light coat of Plastic Mold Spray, SM-O-O-TH Silicone Spray or equivalent. This will prevent the harness grommet from sticking to the magneto distributor block.

- a. Place the harness terminal plate on the magneto and tighten the nuts around the plate alternately to seat the cover squarely on the magneto. Torque the nuts to 18 to 22 inch-pounds.
- b. Route the ignition wires to their respective cylinders as shown in Figure 8-28.
- c. Clamp the harness assembly in position.
- d. Connect the leads to the spark plugs.

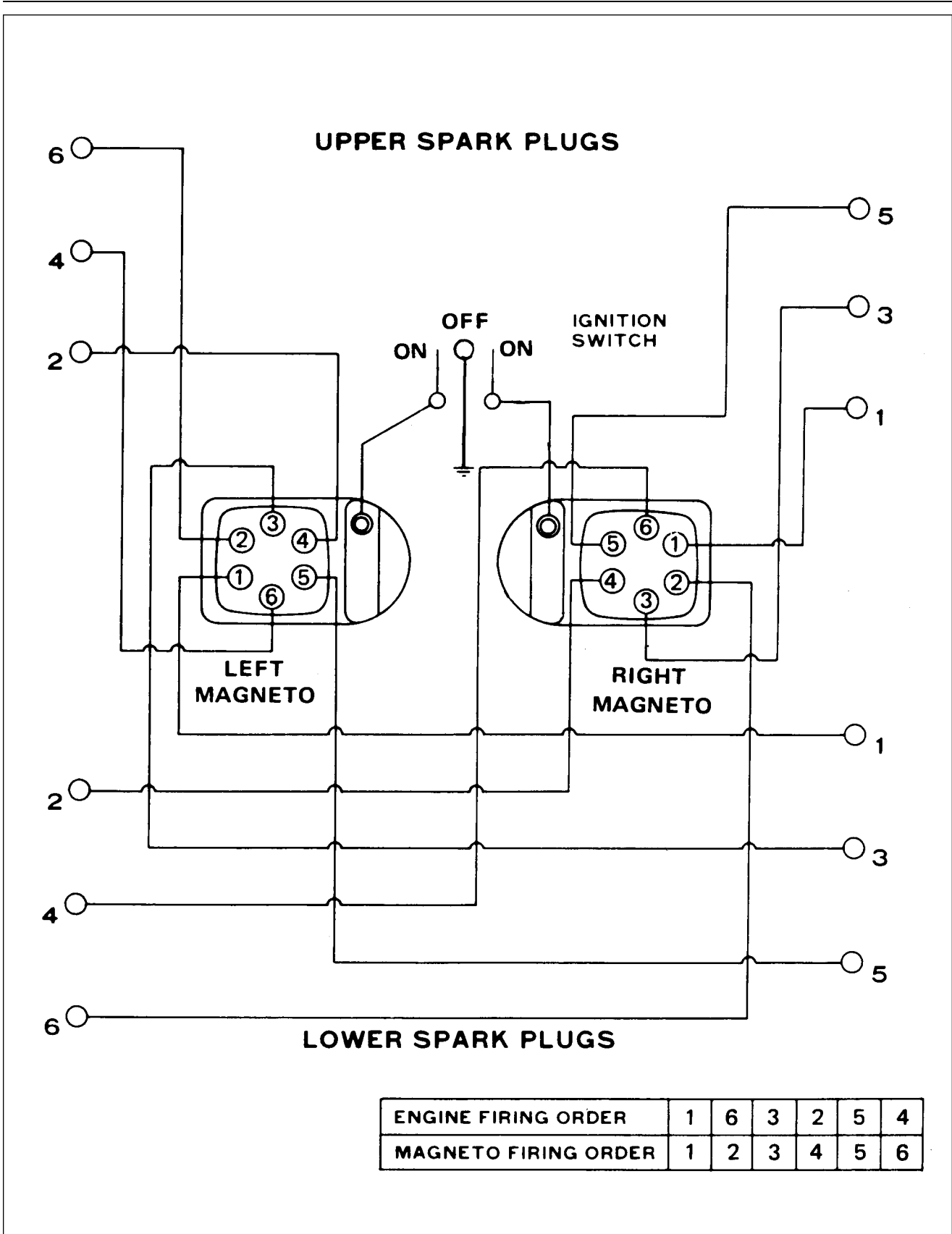

Figure 8-28. Ignition Schematic

8-45. SPARK PLUGS.

8-46. REMOVAL OF SPARK PLUGS.

- a. Loosen the coupling nut on the harness lead and remove the terminal insulator from the spark plug barrel well. (A crows foot adapter is needed to remove the lower spark plugs.)

NOTE

When withdrawing the ignition cable lead connection from the plug, care must be taken to pull the lead straight out and in line with the center line of the plug barrel; otherwise, a side load will be applied which frequently results in damage to the barrel insulator and connector. If the lead cannot be removed easily in this manner, the resisting contact between the neoprene collar and the barrel insulator will be broken by a rotary twisting of the collar. Avoid undue distortion of the collar and possible side loading of the barrel insulator.

- b. Remove the spark plug from the engine. In the course of engine operation, carbon and other combustion products will be deposited on the end of the spark plug and will penetrate the lower threads to some degree. As a result, greater torque is frequently required for removing a plug than for its installation. Accordingly, the torque limitations given do not apply to plug removal, and sufficient torque must be used to unscrew the plug. The higher torque in removal is not as detrimental as in installation, since it cannot stretch the threaded section. It does, however, impose a shearing load on this section and may, if sufficiently severe, produce a failure in this location.

NOTE

Torque indicating handle should not be used for spark plug removal because of the greater torque requirement.

- c. Place spark plugs in a tray that will identify their position in the engine as soon as they are removed.

NOTE

Spark plugs should not be used if they have been dropped.

- d. Removal of seized spark plugs in the cylinder may be accomplished by application of liquid carbon dioxide by a conical metal funnel adapter with a hole at the apex just large enough to accommodate the funnel of a CO₂ bottle. (Refer to Figure 8-29.) When a seized spark plug cannot be removed by normal means, the funnel adapter is placed over and around the spark plug. Place the funnel of the CO₂ bottle inside the funnel adapter and release the carbon dioxide to chill and contract the spark plug. Break the spark plug loose with a wrench. A warm cylinder head at the time the carbon dioxide is applied will aid in the removal of an excessively seized plug.
- e. Do not allow foreign objects to enter the spark plug hole.

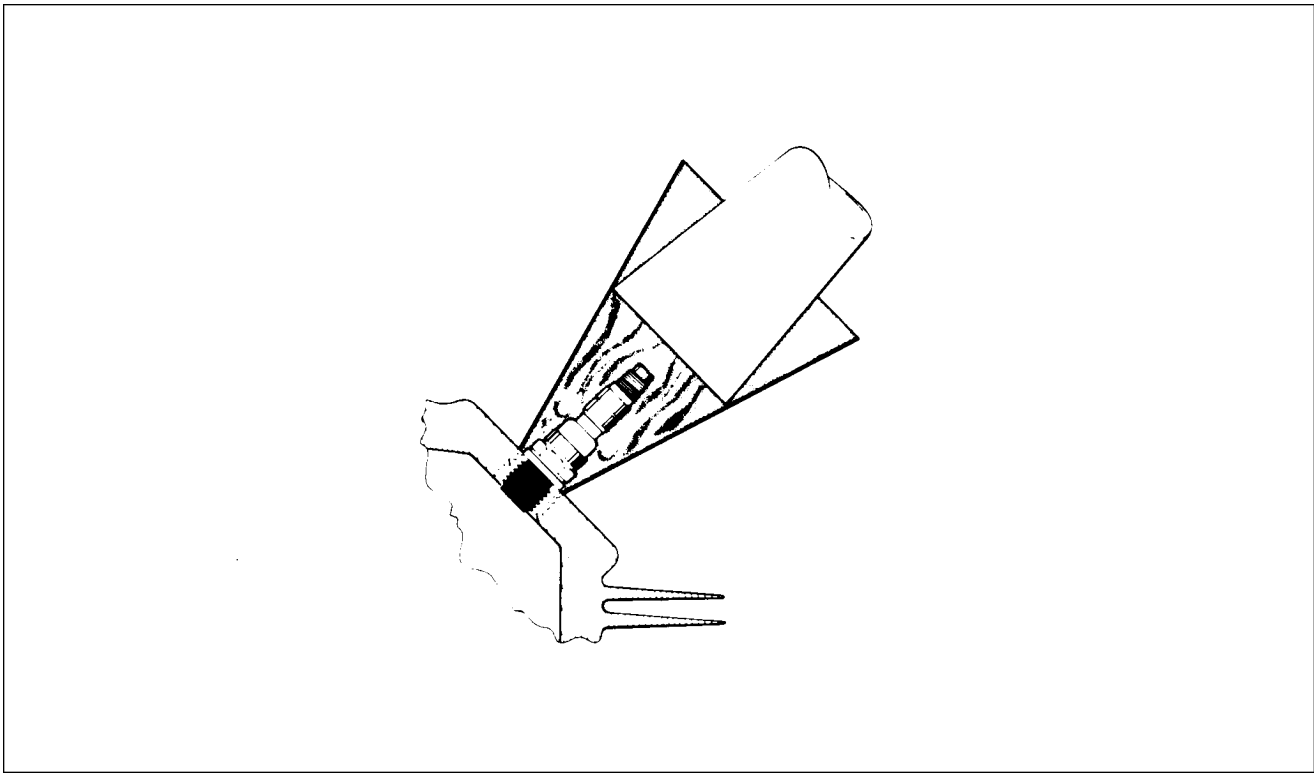

Figure 8-29. Removing Frozen Spark Plug

8-47. INSPECTION AND CLEANING OF SPARK PLUG.

- a. Visually inspect each spark plug for the following non-repairable defects:
 1. Severely damaged shell or shield threads nicked up, stripped or cross-threaded.
 2. Badly battered or rounded shell hexagons.
 3. Out-of-round or damaged shielding barrel.
 4. Chipped, cracked or broken ceramic insulator portions.
 5. Badly eroded electrodes worn to approximately 50% of original size.
- b. Clean the spark plug as required, removing carbon and foreign deposits.
- c. Set the electrode at .015 to .018 inches.
- d. Test the spark plug both electrically and for resistance.

8-48. INSTALLATION OF SPARK PLUGS. Before installing spark plugs, ascertain that the threads within the cylinder are clean and not damaged.

- a. Apply anti-seize compound sparingly on the threads and install gasket and spark plugs. Torque 360 to 420 inch-pounds.

CAUTION

Make certain the deep socket is properly seated on the spark plug hexagon as damage to the plug could result if the wrench is cocked to one side when pressure is applied.

- b. Carefully insert the terminal insulator in the spark plug and tighten the coupling unit.

CHEROKEE ARROW III SERVICE MANUAL

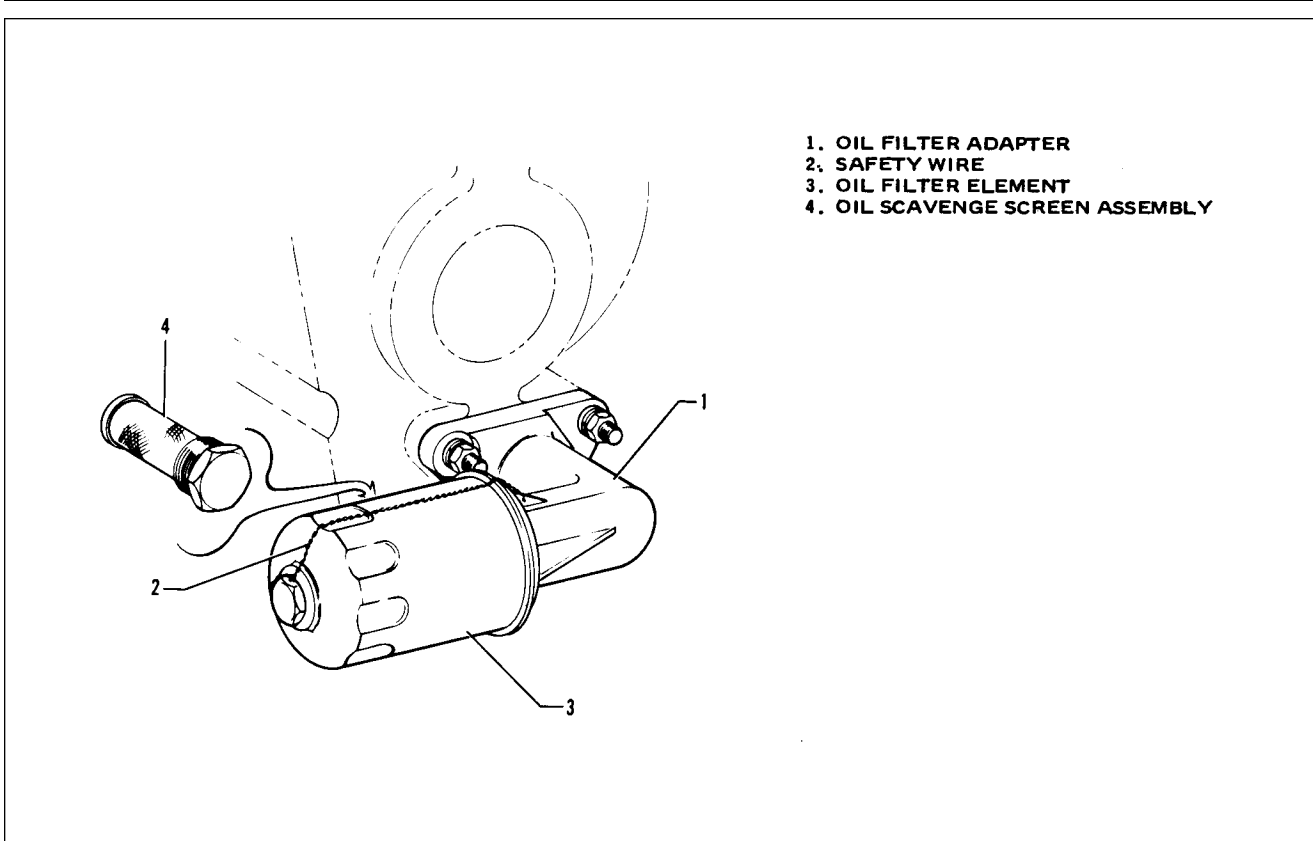

Figure 8-30. Lubrication System Maintenance Points.

8-49. LUBRICATION SYSTEM.

8-50. DESCRIPTION. The oil system is a wet sump, force feed system with a capacity of 8 quarts. A conventional dipstick is provided for determining the oil quantity.

When the engine is running, oil is drawn through a screen and pick up tube which extends from the sump to a port in the crankcase. Oil then flows to the inlet of the gear type, engine driven oil pump and is forced under pressure through the pump outlet. A pressure relief valve prevents excessive oil pressure by allowing excess oil to be returned to the sump. After leaving the pump, the oil under pressure enters a full flow filter and is passed onto the oil cooler. If the filter element becomes blocked, a bypass relief valve will open to permit unfiltered oil to flow to the engine. An oil temperature control unit allows oil to bypass the oil cooler when the oil is cold. Some oil flows through the cooler to prevent congealing in cold weather. When the oil temperature reaches approximately 170°F, the oil temperature control unit actuates to close off the cooler bypass forcing the oil to flow through the cooler.

From the oil cooler oil enters the crankcase where it is directed to the bearing surfaces and other engine components requiring lubrication and cooling. The propeller governor boost engine oil pressure for operation of the propeller. A tap in the side of the crankcase supplies oil pressure for lubrication of the turbocharger bearings. Oil is carried to the turbocharger through an external line. After lubricating the turbocharger bearings it is drawn into a scavenge pump and forced back to the oil sump. Oil within the engine drains, by gravity, back into the sump.

CHEROKEE ARROW III SERVICE MANUAL

8-51. OIL FILTER REPLACEMENT. (Refer to Figure 8-30.) The oil filter element should be replaced after each 50 hours of engine operation. The filter element is mounted on the lower portion of the engine accessory case. Replace the filter element as follows:

- a. Remove the lockwire between the nut on the filter and the oil filter adapter and unscrew the filter element.
- b. Before installing a new filter, lubricate the gasket on the filter with engine oil.
- c. Torque the filter 18 to 20 foot-pounds or 3/4 to 1 full turn after the gasket makes contact.

CAUTION

Do not over torque.

- d. Run the engine and check for oil leaks; then install lockwire between nut on filter and adapter.

8-52. ENGINE FUEL SYSTEM.

8-53. DESCRIPTION. The fuel injection system is a multi-nozzle, continuous flow, altitude compensating system that regulates fuel flow to match engine operating conditions. The system consists of an engine driven fuel pump, a throttle body, a fuel manifold valve and fuel discharge nozzles.

The engine driven fuel pump is a positive displacement, rotary vane type pump with an integral vapor separator and altitude compensating aneroid valve.

The throttle body consists of a rotary valve metering unit attached to an air throttle that controls the flow of air to the engine. The position of the cam shaped edge of the rotary valve across the fuel delivery port and engine driven pump controls the fuel flow to the manifold valve and nozzles, thus controlling the fuel-air ratio.

The fuel manifold valve is the central point for dividing fuel to the individual cylinders. A diaphragm and plunger valve within the manifold valve raises or lowers by fuel pressure to open or close the individual fuel supply ports simultaneously.

The fuel discharge nozzles are an air bleed type nozzle with a calibrated orifice. A nozzle is installed in the cylinder head outside each intake valve for each cylinder.

8-54. FUEL INJECTION SYSTEM MAINTENANCE.

- a. Check all attaching parts for tightness.
- b. Check all fuel lines for leaks, evidence of damage, or chafing by metal to metal contact.
- c. Check control connections, levers, and linkages for safety.
- d. Inspect nozzles for cleanliness with particular attention to air screens and orifices. Use a standard 1/2 inch spark plug type deep socket to remove nozzles. Do not remove shield to clean air screens. Do not use wire or other object to clean orifices. To clean nozzles, remove from engine and immerse in fresh cleaning solvent. Use compressed air to dry.
- e. Unscrew strainer plug from fuel injection control valve and clean screen in solvent. Reinstall, safety, and check for leaks.
- f. During periodic lubrication, add a drop of engine grade oil on each end of the air throttle shaft and at each end of the linkage between the air throttle and fuel metering valve.

NOTE

Do not use any form of thread compound on fuel line fittings. Use only a fuel soluble lubricant such as engine oil.

CHEROKEE ARROW III SERVICE MANUAL

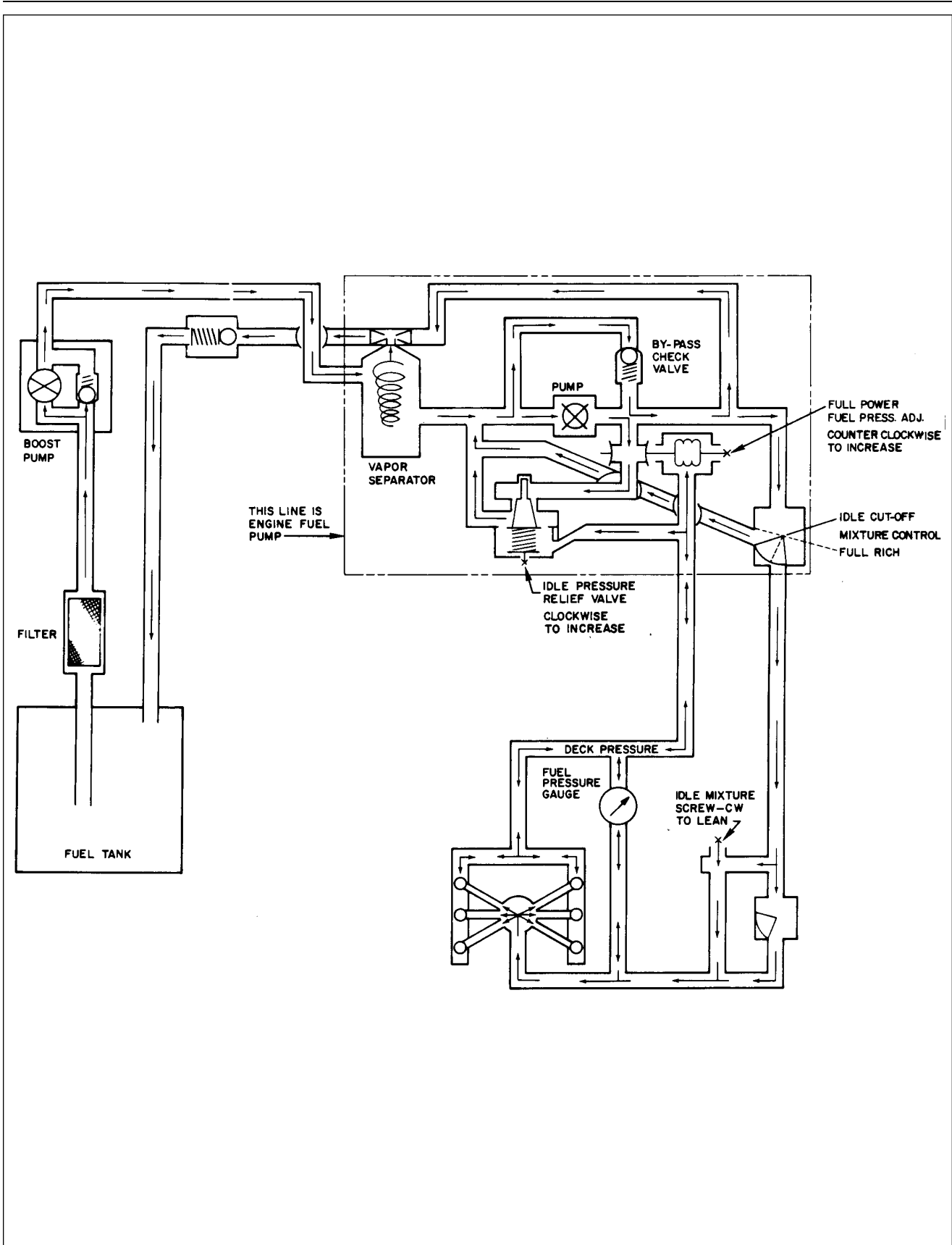

Figure 8-31. Schematic Diagram of Fuel Injection System

CHEROKEE ARROW III SERVICE MANUAL

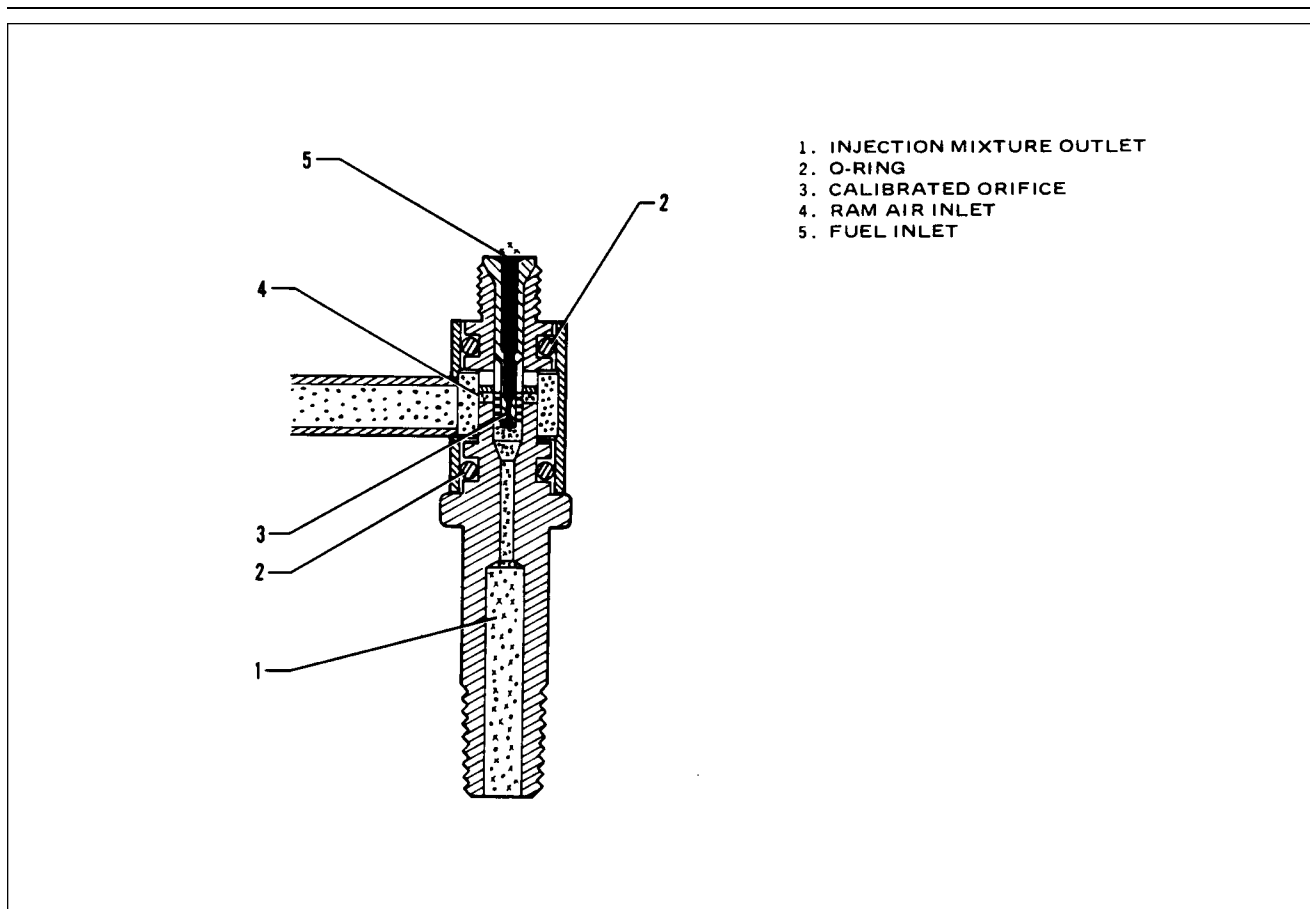

Figure 8-32. Fuel Injector Nozzle Assembly

8-55. FUEL INJECTOR NOZZLE ASSEMBLY.

8-56. REMOVAL OF FUEL INJECTOR NOZZLES.

- a. Remove the cowling side access panels.
- b. Disconnect the fuel line and remove the ram air line from the nozzle.
- c. Use a standard 1/2 inch spark plug type deep socket to remove the nozzle.

8-57. CLEANING AND INSPECTION OF FUEL INJECTOR NOZZLES.

- a. To clean the nozzles immerse in fresh cleaning solvent, use compressed air to dry.

CAUTION

Do not use wire or other objects to clean orifices.

- b. Inspect the nozzles for cleanliness; pay particular attention to the orifices. Check the condition of the nozzle and cylinder threads.

8-58. INSTALLATION OF FUEL INJECTOR NOZZLES.

- a. Carefully start the nozzles by hand to prevent cross-threading. Torque nozzle to 60 inch-pounds.
- b. Connect the fuel line to the nozzle.
- c. Reinstall cowling side panels.

CHEROKEE ARROW III SERVICE MANUAL

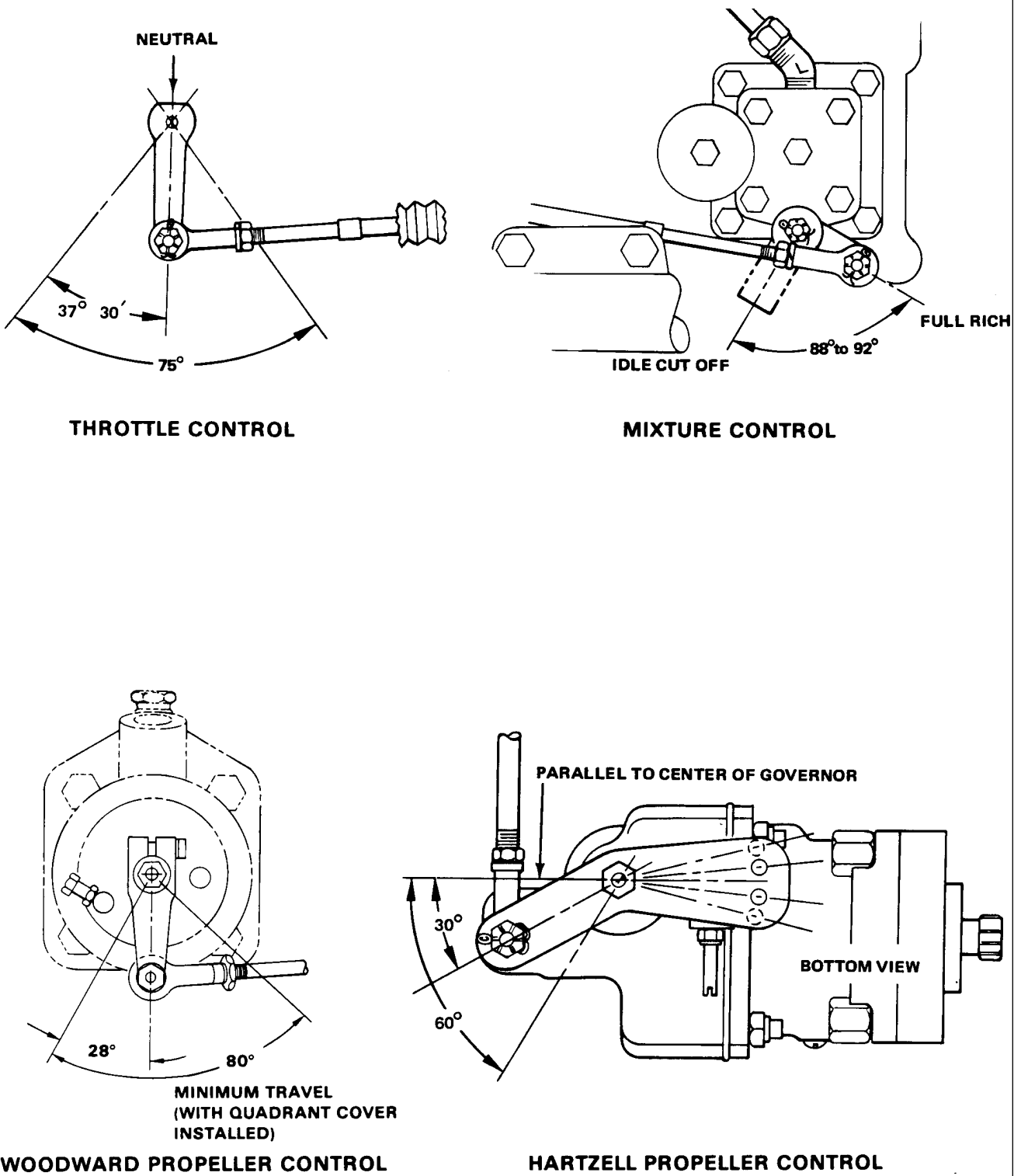

Figure 8-33. Engine Controls

CHEROKEE ARROW III SERVICE MANUAL

8-59. ENGINE AND PROPELLER CONTROLS.

8-60. RIGGING THROTTLE, MIXTURE AND GOVERNOR CONTROLS. (Refer to Figure 8-33.)

- a. Rig the throttle control as follows:
 1. Place the quadrant throttle lever full forward.
 2. With the control arm on the fuel-air control unit in the full throttle position, rig the throttle quadrant lever to provide a minimum of .032 inches clearance from the forward stop. With the control arm at the idle stop, the quadrant throttle lever must have a minimum clearance of .032 inches from the aft stop.
 3. Rig the aft throttle micro-switch to actuate the gear warning horn and red light at a manifold pressure of 14 ± 2 inches with the landing gear retracted.
- b. Rig the propeller control as follows:
 1. Place the propeller control lever full forward.
 2. With the propeller governor control arm in the low pitch (high RPM) position, rig the quadrant control lever to provide .047/.032 inches clearance from the forward stop.
- c. Rig the mixture control as follows:

NOTE: *Check the routing and security of the mixture cable to prevent interference between the cable and the gear linkage.*

1. Place the mixture control lever full forward.
2. With the mixture control arm on the engine fuel pump in the full rich position, rig the quadrant mixture lever to provide a minimum of .032 inches clearance from the forward stop.
3. With the mixture control arm at idle cut-off, the quadrant mixture lever must have a minimum of .032 inches clearance from the aft stop.

8-61. ENGINE SETUP PROCEDURES. The following procedures should be used to check and adjust the power plant to maintain the required operating limits and insure obtaining good setup results. It is important that the following leak check be made before proceeding with any actual system adjustments:

- a. Leak Check - Gauge Lines:
 1. Disconnect the manifold pressure, deck pressure, and fuel pressure lines on the forward side of the rear engine baffle.
 2. Connect surgical tubing to the fuel flow (deck pressure) bulkhead fitting and evacuate the line until a 10 gallon per hour (maximum) positive indication on the fuel flow gauge is obtained. Clamp off the tubing and observe the gauge for a steady reading. Any change of this reading would indicate a leak in the system, which must be repaired prior to continuing with the setup procedures.

NOTE: *A static system test unit can be-used to leak check these lines.*

3. Check the fuel pressure and manifold pressure lines in the same manner as given in Step 2, except apply positive pressure to the lines. Do not exceed 4 pounds per square inch (psi) on the fuel pressure gauge, or 4 inches of mercury (In. Hg) increase on the manifold pressure gauge.
4. Visually inspect manifold pressure, deck pressure and fuel pressure lines forward of the engine rear baffle for general condition which could cause leakage. Check all "B" nuts for tightness.
5. Reconnect the manifold pressure, fuel flow and fuel pressure lines at the bulkhead fitting.
6. Disconnect the main fuel supply line to the engine driven fuel pump, at the rear engine baffle and using the auxiliary fuel pump, pump out approximately one quart of gasoline; then reconnect the line.
7. Using the electric fuel boost pump, purge the air from the fuel flow gauge line at the back of the instrument; then reconnect the line.

CHEROKEE ARROW III SERVICE MANUAL

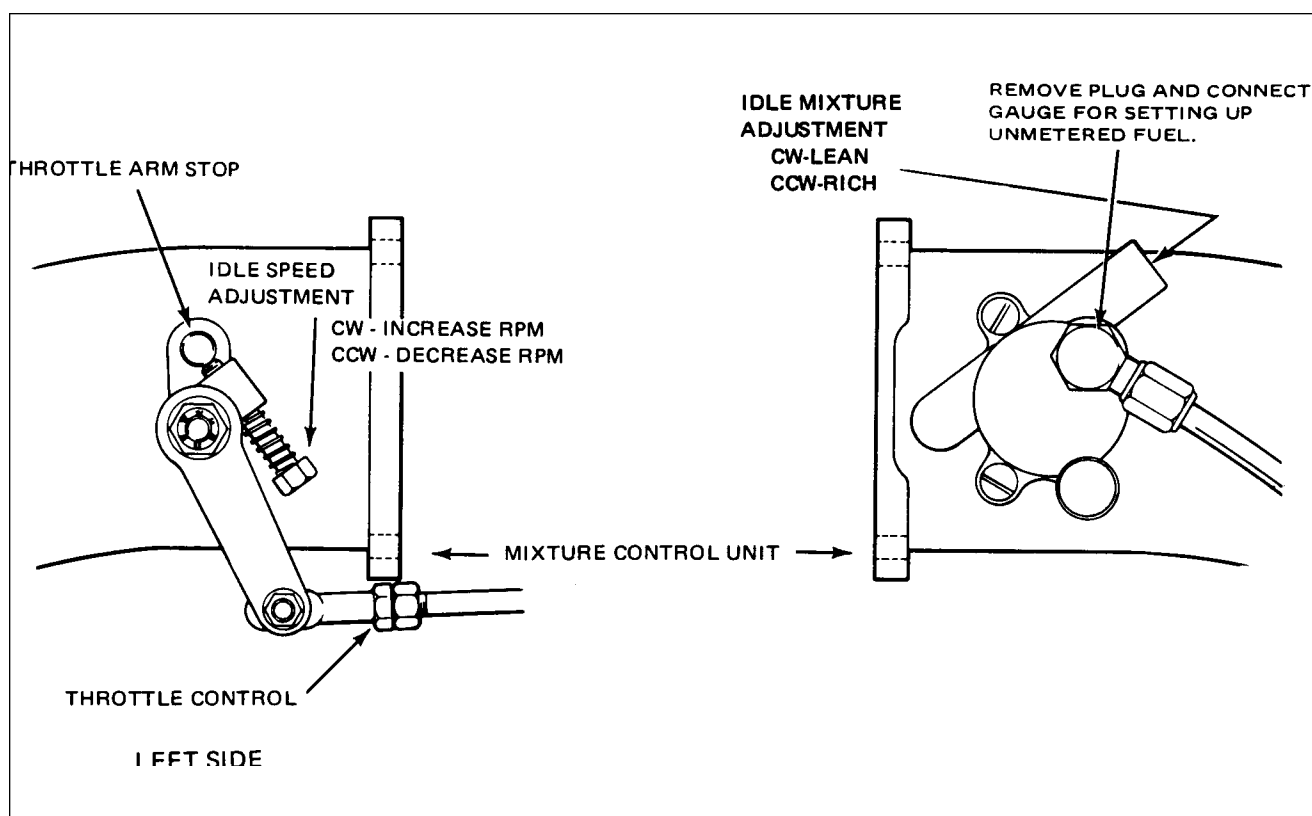

Figure 8-34. Idle Speed and Mixture Adjustment Points

- b. Exhaust Bypass Check: Ascertain that the exhaust bypass adjusting screw has from eight to nine threads showing below the jam nut. This screw is preset at the factory and should not require any adjustment, unless it is known that critical altitude is not correct; in this case, use procedure given in Step k. (Refer to Figure 8-36.)
- c. Idle Performance Check:

NOTE

It is extremely important that the engine be thoroughly warmed up. However, excessive engine temperatures must be avoided since setup temperature must closely parallel temperatures in flight.

1. Remove the cap from the tee fitting on the right side of the throttle body. (Refer to Figure 8-34.)
2. Install a 0-60 psig calibrated pressure gauge (vented to the atmosphere) to the tee, using a suitable length of flexible tube. The gauge should always be at the same level as the fuel manifold valve when checking fuel pressure.
3. Purge the air from the tube.

CAUTION

During all engine operations outlined in these instructions, exercise CAUTION to avoid harm or damage to personnel and equipment by propeller blast and rotating propeller blades.

d. Check and Adjustment of Idle Fuel Pressure:

NOTE

The following setup procedure is accomplished with the boost pump OFF and the engine thoroughly warmed up.

1. Back off the idle speed adjusting screw two turns. (Refer to Figure 8-34.)
 2. Start engine and warm up at 1,500 to 1,800 RPM until the oil pressure is in the green arc, cylinder head temperature is in the lower one quarter of the green arc, and the oil temperature is 160° to 180° F.
 3. While maintaining 700 ± 25 RPM, set the idle fuel pressure at 6.5 ± 0.25 psi by adjusting the idle pump adjustment screw (refer to Figure 8-35, item 6); clockwise adjustment increases pressure; counterclockwise adjustment decreases pressure.
- e. Check and Adjustment of Idle Mixture: (Refer to Figure 8-34.)
1. Operate the engine at 1,500 to 1,800 RPM until cylinder head temperature is in the lower one quarter of the green arc, and the oil temperature is 160° to 180°F.
 2. Reduce the engine speed and stabilize it at 700 ± 25 RPM.
 3. Slowly, but positively, move the mixture control from the full rich position to the idle cut-off. The engine speed should increase 75 to 100 RPM before beginning to drop toward zero (Upper cowling removed).
 4. If the engine speed increase is less than 75 RPM, adjust the idle mixture adjustment to enrich the mixture (counterclockwise). If the engine speed increase is more than 100 RPM, adjust the idle mixture to lean the mixture (clockwise). Recheck the adjustment as outlined in Step 3, to insure the idle mixture is adjusted within limits specified.
- f. Check and Adjustment of Idle Speed: (Refer to Figure 8-34.)
1. With the idle fuel pressure and idle mixture set in accordance with instructions given in Steps “d” and “e,” cylinder head temperature in the lower one-quarter of the green arc, and oil temperature at 160° to 180°F, set engine speed at $700 + 25$ RPM and wait till it stabilizes.
 2. Adjust the idle speed adjusting screw until contact is made with the throttle arm stop.

NOTE

After final adjustment, recheck the idle fuel pressure, mixture and speed to ascertain that all are within specifications given in previous steps.

CHEROKEE ARROW III SERVICE MANUAL

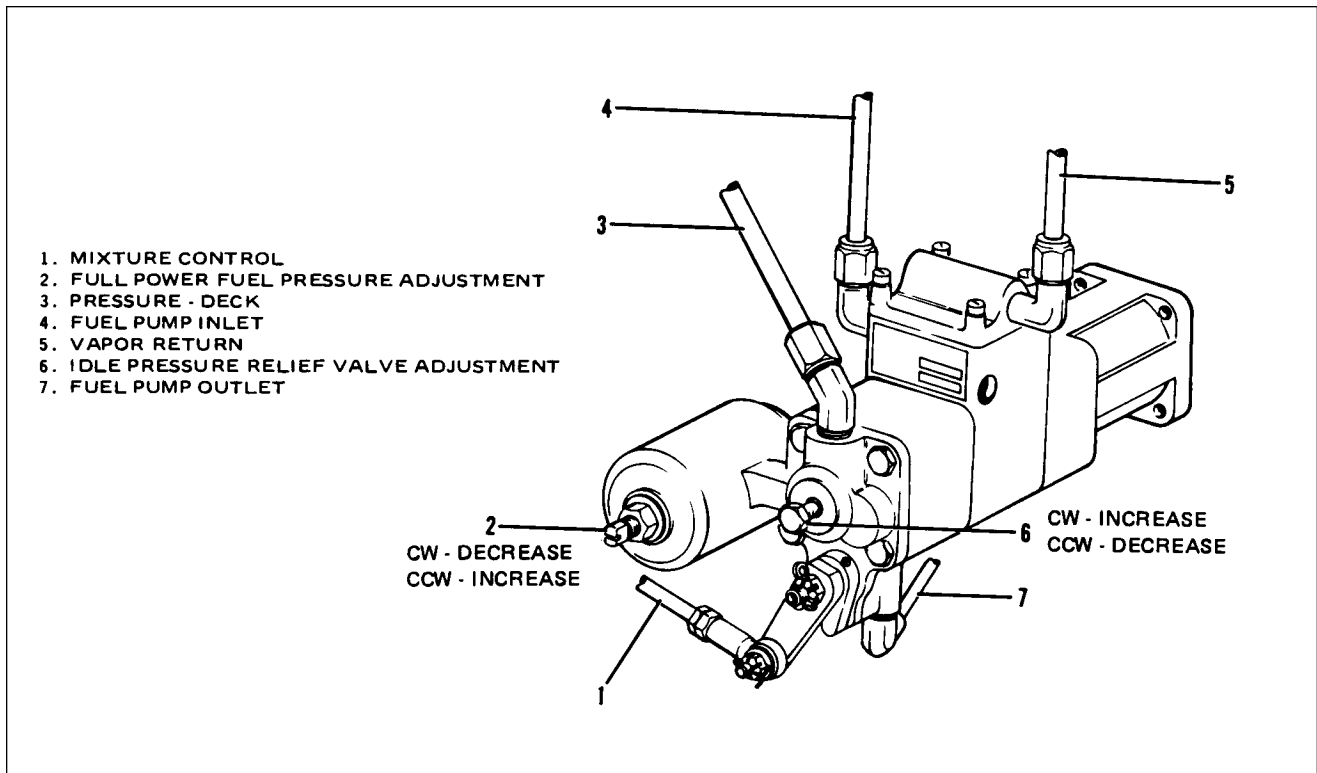

Figure 8-35. Sectional View of Altitude Compensating Fuel Pump Assembly

- g. Adjustment for Full Power Performance: (Refer to Figure 8-35.)

CAUTION

Before attempting full power checks, be sure that the brakes are properly maintained and set, and that the ground conditions will not permit the wheels to slip during full power check.

NOTE

Fuel flows are given for sea level density altitude.

1. Set the engine at 40.6 to 40.9 in. Hg manifold pressure (overboost light activated) and engine at 2575 ± 25 RPM. Readjust the throttle as required to maintain 40.6 to 40.9 in. Hg manifold.
2. Fuel flow should be 23.0 to 23.5 gallons per hour (gph), with the mixture controls in the full rich position.
3. If adjustment is required, loosen the jam nut on the adjusting screw located on the aneroid housing of the fuel pump. (Refer to Figure 8-35, item 2.) Clockwise adjustment decreases fuel flow reading; counterclockwise adjustment increases fuel flow reading; one full turn will cause a 1.0 to 1.5 gph change. Use CAUTION when loosening and tightening the jam nut so as not to change settings or over torque the jam nut.

NOTE

If other than minor adjustments are required to the fuel flow, a complete investigation of interface systems is required.

CHEROKEE ARROW III SERVICE MANUAL

h. Rechecking System:

1. Recheck the idle settings per instructions c, d, e and f, and adjust as required.
2. Recheck Full Power Fuel Flow settings per instruction g, and adjust as required.
3. With engine operating at 2575 RPM (40.8 to 41.0 in. Hg manifold pressure), lean the mixture to obtain 21 gph fuel flow readings. The unmetereed fuel pressure on the calibrated pressure gauge should be 37 to 40 psi.
4. With engines operating at 2575 RPM and 40.8 to 41.0 in. Hg manifold pressure, mixture control full rich, reduce RPM and increase throttle until throttle is open. 41.0 in. Hg manifold pressure should be obtained at approximately 2225 ± 25 RPM.

i. Remove test equipment; safety wire the exhaust bypass screw and check nut to the bypass screw housing; reinstall the cap on the tee of the throttle body housing.

j. The accuracy of the cockpit fuel flow gauge at maximum power can be checked against a calibrated gauge by connecting the calibrated gauge at the manifold valve and maintaining the gauge on the same level as the valve while checking pressures and using Chart VIII-I.

NOTE

The calibrated gauge fuel line must be purged of air, and the reference side of the calibrated gauge vented to turbo discharge pressure.

k. Flight Test: A complete flight test should be made for final adjustments of fuel flow and bypass valve. The following steps should be followed:

1. At 8,000 feet density altitude, set the engines to operate at $2,450 \pm 25$ RPM and 33.0 to 34.0 in. Hg manifold pressure.
2. Lean the engine to 25°F rich of peak exhaust gas temperature (EGT).
3. Fuel flow at these conditions should be 12.0 ± 0.5 gph.
4. With full rich mixture, full throttle, $2,575 \pm 25$ RPM, and 105 MPH airspeed. the manifold pressure should decrease until the overboost lights goes off (40.8 to 41.0 in. Hg), at some point between 11,500 feet minimum, 12,500 feet maximum density altitude. This point is known as the "critical altitude." At this point the fuel flow should be 22.0 to 24.0 gph indicated.
5. If a discrepancy in critical altitude was noted, adjust the exhaust bypass valve. (Turning the exhaust bypass valve screw in one full turn will increase the critical altitude approximately 1,000 feet.) Adjustments of critical altitude in excess of 500 feet may require retrimming of the fuel flows at 100% power.
6. With full rich mixture, 2,575 RPM, 105 MPH airspeed, and 1,000 to 3,000 feet density altitude, check the operation of the manifold pressure relief valve. Slowly advance one throttle to the wide open position. The manifold pressure shall stabilize between 42.0 and 44.0 in. Hg; there shall be no loss of power, and the fuel flow indication shall be well over the red line. Do not exceed 41.0 in. Hg manifold pressure for more than ten seconds.

NOTE

Idle speed and idle mixture indication is a function of engine temperatures. Therefore, at normal ground idle temperatures (cylinder and oil temperature indications may or may not be "in the green") idle speed will be approximately 700 RPM, and the idle mixture check will result in a 25 to 50 RPM increase in engine speed .

CHEROKEE ARROW III SERVICE MANUAL

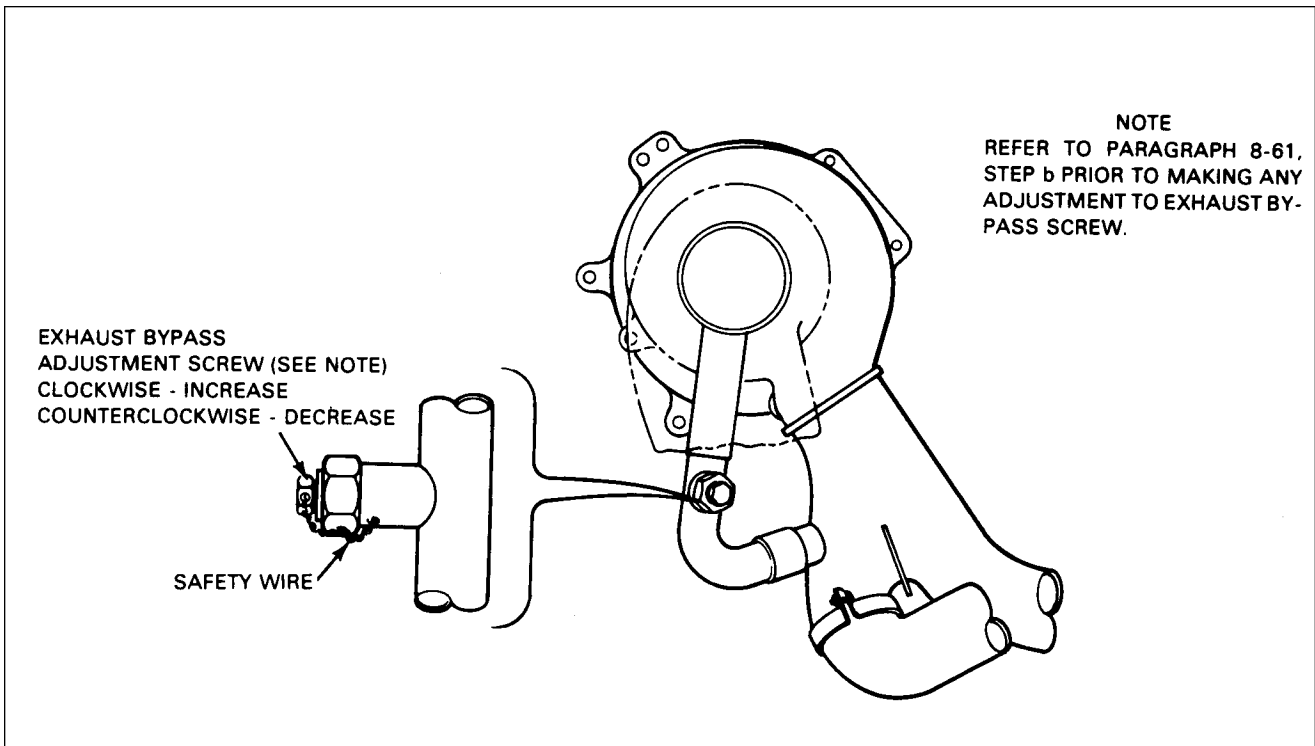

Figure 8-36. Exhaust Bypass Screw

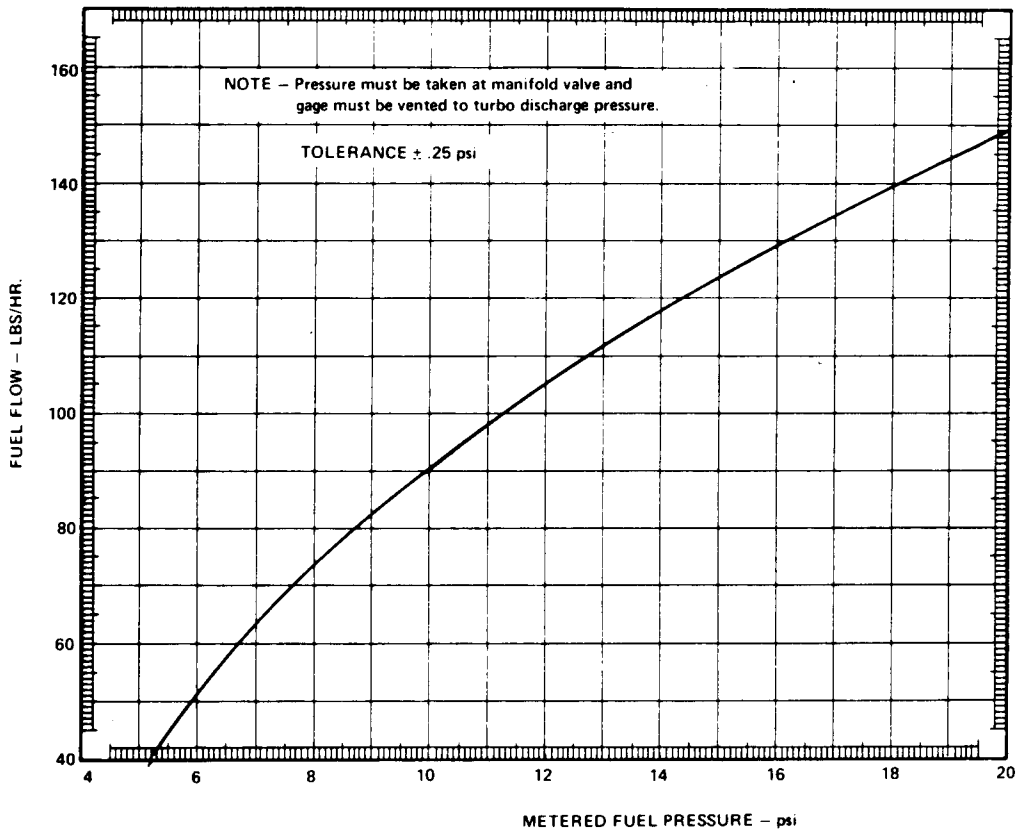

CHART VIII-I. METERED FUEL ASSEMBLY CALIBRATION

CHEROKEE ARROW III SERVICE MANUAL

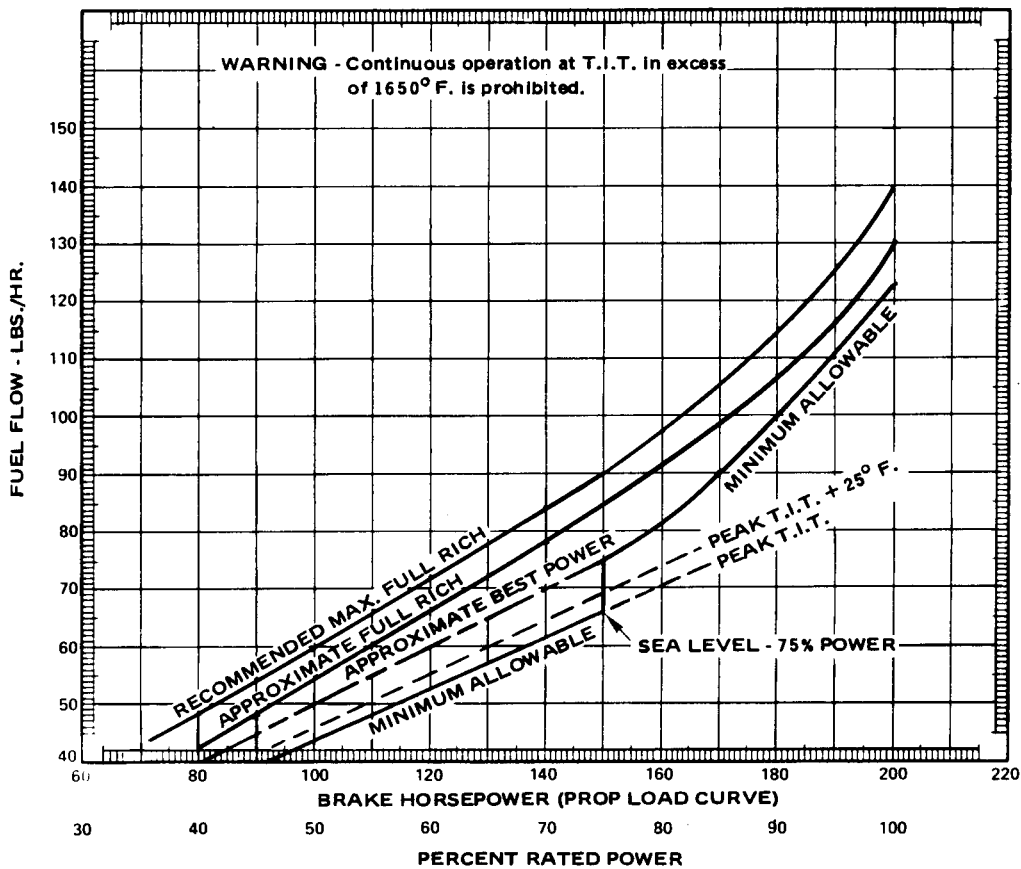

CHART VIII-II. LIMITS - FUEL FLOW VS. BRAKE H.P.

CHEROKEE ARROW III SERVICE MANUAL

TABLE VIII-III. TROUBLESHOOTING CHART (ENGINE)

Trouble	Cause	Remedy
<p>Engine will not start.</p>	<p>No fuel gauge pressure - no fuel to engine.</p> <p>Have gauge pressure - engine flooded.</p> <p>Have gauge pressure - no fuel to engine.</p>	<p>Check fuel control for proper position, auxiliary pump "ON" and operating, feed valves open. Fuel filters open and tank fuel level.</p> <p>Turn off auxiliary pump and ignition switch; set throttle to "FULL OPEN" and fuel control to "IDLE CUTOFF," and crank engine to clear cylinders of excess fuel. Repeat starting procedure.</p> <p>Check for bent or loose fuel lines. Loosen line at fuel nozzle. If no fuel shows, replace fuel manifold valve.</p>
<p>Engine starts but fails to keep running.</p>	<p>Inadequate fuel to fuel manifold valve.</p> <p>Defective ignition system.</p>	<p>Set fuel control in "FULL RICH" position; turn auxiliary pump "ON," check to be sure feed lines and filters are not restricted. Clean or replace defective components.</p> <p>Check accessible ignition cables and connections. Tighten loose connections. Replace defective spark plugs.</p>
<p>Engine runs rough at idle.</p>	<p>Improper idle mixture adjustment.</p> <p>Fouled spark plugs.</p> <p>Discharge nozzle air vent manifold restricted or defective.</p>	<p>Readjust idle setting. Turn adjustment screw clockwise to lean mixture and counterclockwise to richen mixture.</p> <p>Remove and clean plugs, adjust gaps. Replace defective plugs.</p> <p>Check for bent or loose connections. Tighten loose connections. Check for restrictions and replace defective components.</p>

CHEROKEE ARROW III SERVICE MANUAL

TABLE VIII-III. TROUBLESHOOTING CHART (ENGINE) (cont.)

Trouble	Cause	Remedy
<p>Engine has poor acceleration.</p>	<p>Idle mixture too lean.</p> <p>Incorrect fuel-air mixture, worn control linkage or restricted air cleaner.</p> <p>Defective ignition system.</p> <p>Malfunctioning turbocharger.</p>	<p>Readjust idle mixture.</p> <p>Tighten loose connections. Service air cleaner.</p> <p>Check accessible cables and connections. Replace defective spark plugs.</p> <p>Check operation; listen for unusual noise. Check exhaust bypass screw and for exhaust system defects. Tighten loose connections.</p>
<p>Engine runs rough at speeds above idle.</p>	<p>Improper fuel-air mixture.</p> <p>Restricted fuel nozzle.</p> <p>Ignition system and spark plugs defective.</p>	<p>Check manifold connections for leaks. Tighten loose connections. Check fuel control for setting and adjustment. Check fuel filters and screens for dirt. Check for proper pump pressure and readjust as necessary.</p> <p>Remove and clean all nozzles.</p> <p>Clean and regap spark plugs. Check ignition cables for defects. Replace defective components.</p>
<p>Engine lacks power, reduction in maximum manifold pressure or critical altitude.</p>	<p>Incorrectly adjusted throttle control, "sticky" linkage or dirty air cleaner.</p> <p>Improperly adjusted waste gate valve.</p>	<p>Check movement of linkage by moving control from idle to full throttle. Make proper adjustments and replace worn components. Service air cleaner.</p> <p>Check exhaust bypass screw adjustment. (Refer to Paragraph 8-61.)</p>

CHEROKEE ARROW III SERVICE MANUAL

TABLE VIII-III. TROUBLESHOOTING CHART (ENGINE) (cont.)

Trouble	Cause	Remedy
Engine lacks power, reduction in maximum manifold pressure or critical altitude. (cont.)	Defective ignition system.	Inspect spark plugs for fouled electrodes, heavy carbon deposits, erosion of electrodes, improperly adjusted electrode gaps and cracked porcelains. Test plugs for regular firing under pressure. Replace damaged or misfiring plugs. Spark plug gap to be 0.015 to 0.019 in.
	Loose or damaged exhaust system.	Inspect entire exhaust system to turbocharger for cracks and leaking connections. Tighten connections and replace damaged parts.
	Loose or damaged intake manifold.	Inspect entire manifold system for possible leakage at connections. Replace damaged components; tighten all connections and clamps.
	Fuel nozzles defective.	Inspect fuel nozzle vent manifold for leaking connection. Tighten and repair as required. Check for restricted nozzles and lines and clean or replace as necessary.
	Malfunctioning turbocharger.	Check for unusual noise in turbocharger. If malfunction is suspected, remove exhaust and/or air inlet connections and check rotor assembly for possible rubbing in housing, damaged rotor or defective bearings. Replace turbocharger if damage is noted.
	Exhaust system gas leakage.	Inspect exhaust system for gas leakage, gaskets at turbine inlet flanges, etc., and correct.

CHEROKEE ARROW III SERVICE MANUAL

TABLE VIII-III. TROUBLESHOOTING CHART (ENGINE) (cont.)

Trouble	Cause	Remedy
<p>Low fuel pressure.</p>	<p>Restricted flow to fuel metering valve.</p> <p>Fuel nozzle vent system defective causing improper pressure regulation.</p> <p>Fuel control lever interference.</p> <p>Incorrect fuel injector pump adjustment and operation.</p> <p>Defective fuel injector pump relief valve.</p> <p>Air leakage in fuel pump pressurization line.</p>	<p>Check mixture control for full travel. Check for restrictions in fuel filters and lines; adjust control and clean filters. Replace damaged parts.</p> <p>Check venting system for leaks at connections and other defects. Tighten connections and replace defective parts.</p> <p>Check operation of throttle control and for possible contact with cooling shroud. Adjust as required to obtain correct operation.</p> <p>Check and adjust using appropriate equipment. Replace defective pump.</p> <p>Replace pump if cleaning and lapping valve does not correct problem.</p> <p>Locate cause of leakage and correct.</p>
<p>High fuel pressure.</p>	<p>Restricted flow beyond fuel control assembly.</p> <p>Defective relief valve operation in fuel injector</p>	<p>Check for restricted fuel nozzles or fuel manifold valve. Clean or replace nozzles. Replace defective fuel manifold valve.</p> <p>Check fuel injector pump control line from turbo-charger for loose connections and defects. Tighten connections, replace damaged line.</p>

CHEROKEE ARROW III SERVICE MANUAL

TABLE VIII-III. TROUBLESHOOTING CHART (ENGINE) (cont.)

Trouble	Cause	Remedy
<p>High fuel pressure. (cont.)</p>	<p>Restricted re-circulation passage in fuel injector.</p> <p>Air leakage in fuel gauge vent pressurization line.</p>	<p>Replace pump.</p> <p>Locate cause of leakage and eliminate.</p>
<p>Fluctuating fuel pressure.</p>	<p>Vapor in fuel system.</p> <p>Fuel gauge line leak or improperly purged lines.</p>	<p>Normally operating the auxiliary pump will clear system. Operate auxiliary pump and purge system.</p> <p>Purge gauge line and tighten connections.</p>
<p>Low oil pressure on engine gauge.</p>	<p>Insufficient oil in oil sump, oil dilution or using improper grade oil for prevailing ambient temperature.</p> <p>High oil temperature.</p> <p>Leaking, damaged or loose oil line connections- Restricted screens and filter.</p>	<p>Add oil or change oil to proper viscosity.</p> <p>Defective vernatherm valve in oil cooler; oil cooler restriction. Replace valve or clean oil cooler.</p> <p>Check for restricted lines and loose connections, and for partially plugged oil filter and screens. Clean parts, tighten connections, and replace defective parts.</p>

CHEROKEE ARROW III SERVICE MANUAL

TABLE VIII-III. TROUBLESHOOTING CHART (ENGINE) (cont.)

Trouble	Cause	Remedy
Low oil pressure on engine gauge. (cont.)	Leaking oil seal in turbocharger. Defective check valve in turbocharger oil supply line.	Check for oil in turbocharger exhaust outlet. Replace turbocharger. Disassemble and clean valve or replace.
Poor engine idle cutoff.	Engine getting fuel.	Check fuel control for being in full "IDLE CUTOFF" position. Check auxiliary pump for being "OFF." Check for leaking fuel manifold valve. Replace defective components.
White smoke exhaust.	Turbo coking oil forced through seal in turbine housing.	Clean or change turbocharger.

**SECTION VIII
POWER PLANT [LYCOMING]**

Aerofiche
Grid No.

Paragraph	Aerofiche Grid No.
8A-1. Introduction	2C19
8A-1a. Standard Practices-Engine.....	2C19
8A-2. Description	2C20
8A-3. Troubleshooting.....	2C20
8A-4. Propeller	2C20
8A-5. Removal of Propeller.....	2C20
8A-6. Cleaning, Inspection and Repair of Propeller.....	2C22
8A-7. Installing Propeller	2C23
8A-8. Blade Track.....	2C23
8A-9. Propeller Governor.....	2C23
8A-10. Removal of Propeller Governor	2C23
8A-11. Installation of Propeller Governor.....	2C23
8A-12. Rigging and Adjustment of Propeller Governor	2C24
8A-13. Engine.....	2D1
8A-13a. Installation of Bushings and Pins for Fiberglass Type Cowlings.....	2D1
8A-14. Removal of Engine.....	2D2
8A-15. Installation of Engine	2D3
8A-15a. Installation of Oil Cooler.....	2D6
8A-16. Adjustment of Throttle and Mixture Controls.....	2D6
8A-17. Induction Air Filter.....	2D7
8A-18. Alternate Air Door.....	2D8
8A-19. Fuel Injector.....	2D8
8A-20. Fuel Injector Maintenance.....	2D8
8A-21. Adjustment of Idle Speed and Mixture	2D10
8A-22. Fuel-Air Bleed Nozzle.....	2D10
8A-23. Removal of Fuel-Air Bleed Nozzle.....	2D10
8A-24. Cleaning and Inspection of Fuel-Air Bleed Nozzle.....	2D10
8A-25. Ignition System Maintenance.....	2D12
8A-26. Magneto.....	2D12
8A-27. Inspection of Magneto.....	2D12
8A-28. Removal of Magneto.....	2D14
8A-29. Timing Procedure (Internal Timing).....	2D14
8A-30. Installation and Timing Procedure (Timing Magneto to Engine).....	2D16
8A-31. Harness Assembly.....	2D18
8A-32. Inspection of Harness.....	2D18
8A-33. Removal of Harness	2D20
8A-34. Maintenance of Harness	2D20
8A-35. Installation of Harness.....	2D24
8A-36. Spark Plugs.....	2D24
8A-37. Removal of Spark Plugs.....	2D24
8A-38. Inspection and Cleaning of Spark Plugs.....	2E1
8A-39. Installation of Spark Plugs.....	2E2
8A-40. Lubrication System.....	2E2
8A-41. Oil Pressure Relief Valve.....	2E2
8A-42. Engine Oil Quick Drain Valve.....	2E2

SECTION VIIIA

POWER PLANT LYCOMING (PA-28R-201)

WARNING

When servicing or inspecting vendor equipment installed in Piper Aircraft, it is the user's responsibility to refer to the applicable vendor publication.

8A-1. INTRODUCTION. This section covers the power plant used in PA-28R-201 airplanes and is comprised of instructions for the removal, minor repair, service and installation of the propeller, propeller governor, engine, induction system, fuel injector, fuel air bleed nozzle, ignition system and lubrication system.

For further instructions on major repairs, consult the appropriate publication of the engine or component manufacturer.

8A-1a. STANDARD PRACTICES-ENGINE. The following suggestions should be applied wherever they are needed when working on the power plant.

The following suggestions should be applied wherever they are needed when working on the power plant.

- a. To ensure proper reinstallation and/or assembly, tag and mark all parts, clips, and brackets as to their location prior to their removal and/or disassembly.
- b. During removal of various tubes or engine parts, inspect them for indications of scoring, burning or other undesirable conditions. To facilitate reinstallation, observe the location of each part during removal. Tag any unserviceable part and/or units for investigation and possible repair.
- c. Extreme care must be taken to prevent foreign matter from entering the engine, such as lockwire, washers, nuts, dirt, dust, etc. This precaution applies whenever work is done on the engine, either on or off the aircraft. Suitable protective caps, plugs, and covers must be used to protect all openings as they are exposed.

NOTE

Dust caps used to protect open lines must always be installed OVER the tube ends and NOT IN the tube ends. Flow through the lines may be blocked off if lines are inadvertently installed with dust caps in the tube ends.

- d. Should any items be dropped into the engine, the assembly process must stop and the item removed, even though this may require considerable time and labor. Ensure that all parts are thoroughly clean before assembling.
- e. Never reuse any lockwire, lockwashers, tablocks, tabwashers or cotter pins. All lockwire and cotter pins must fit snugly in holes drilled in studs and bolts for locking purposes. Cotter pins should be installed so the head fits into the castellation of the nut, and unless otherwise specified, bend one end of the pin back over the stud or bolt and the other end down flat against the nut. Use only corrosion resistant steel lockwire and/or cotter pins. Bushing plugs shall be lockwired to the assembly base or case. Do not lockwire the plug to the bushing.
- f. All gaskets, packings and rubber parts must be replaced with the new items of the same type at reassembly. Ensure the new nonmetallic parts being installed show no sign of having deteriorated in storage.
- g. When installing engine parts which require the use of a hammer to facilitate assembly or installation, use only a plastic or rawhide hammer.

CHEROKEE ARROW III SERVICE MANUAL

- h. Anti-seize lubrication should be applied to all loose-fit spline drives which are external to the engine and have no other means of lubrication. For certain assembly procedures, molybdenum disulfide in either paste or powdered form mixed with engine oil or grease may be used.

—CAUTION—

Ensure that Anti-seize compounds are applied in thin even coats, and that excess compound is completely removed to avoid contamination of adjacent parts.

8A-2. DESCRIPTION. The PA-28R-201 is powered by an Avco-Lycoming IO-360-C1C6 engine of 200 horsepower. (Refer to Power Plant Specifications in Table II-I.) The engine is furnished with starter, 60 ampere, 14-volt alternator, voltage regulator, shielded ignition systems, vacuum pump drive, fuel pump, fuel injector and dry paper type induction air filter. An alternate air door that will open automatically in the event of air stoppage through the filter or may be operated manually with the use of a control in the cockpit is provided in the induction system.

The exhaust system is constructed of stainless steel, directing gases inboard to a muffler located directly under the engine. The large muffler with a heater shroud provides heat for both the cabin and defrosting.

The engine is provided with a constant speed propeller controlled by a governor mounted on the engine supplying oil through the propeller shaft at various pressures.

8A-3. TROUBLESHOOTING. Troubles peculiar to the power plant are listed in Table VIIIA-II along with their probable causes and suggested remedies. When troubleshooting the engine, ground the magneto primary circuit before performing any checks of the engine.

8A-4. PROPELLER.

8A-5. REMOVAL OF PROPELLER.

- a. Insure master and magneto switches are off.
- b. Move fuel selector to off position.
- c. Place mixture control in idle cut-off.

NOTE

Before removing spinner components, reference each mating part to facilitate in alignment for reassembly.

- d. Remove spinner by removing attaching screws.
- e. Remove propeller assembly by the following procedure:
 - 1. Support propeller assembly with appropriate sling and hoist.
 - 2. Place drip pan under the propeller to catch oil spillage.
 - 3. Remove safety wire from propeller mounting nuts. Loosen the nuts about 1/4 inch and pull propeller assembly forward against the nuts to allow oil to drain from the propeller and engine cavities.

CHEROKEE ARROW III SERVICE MANUAL

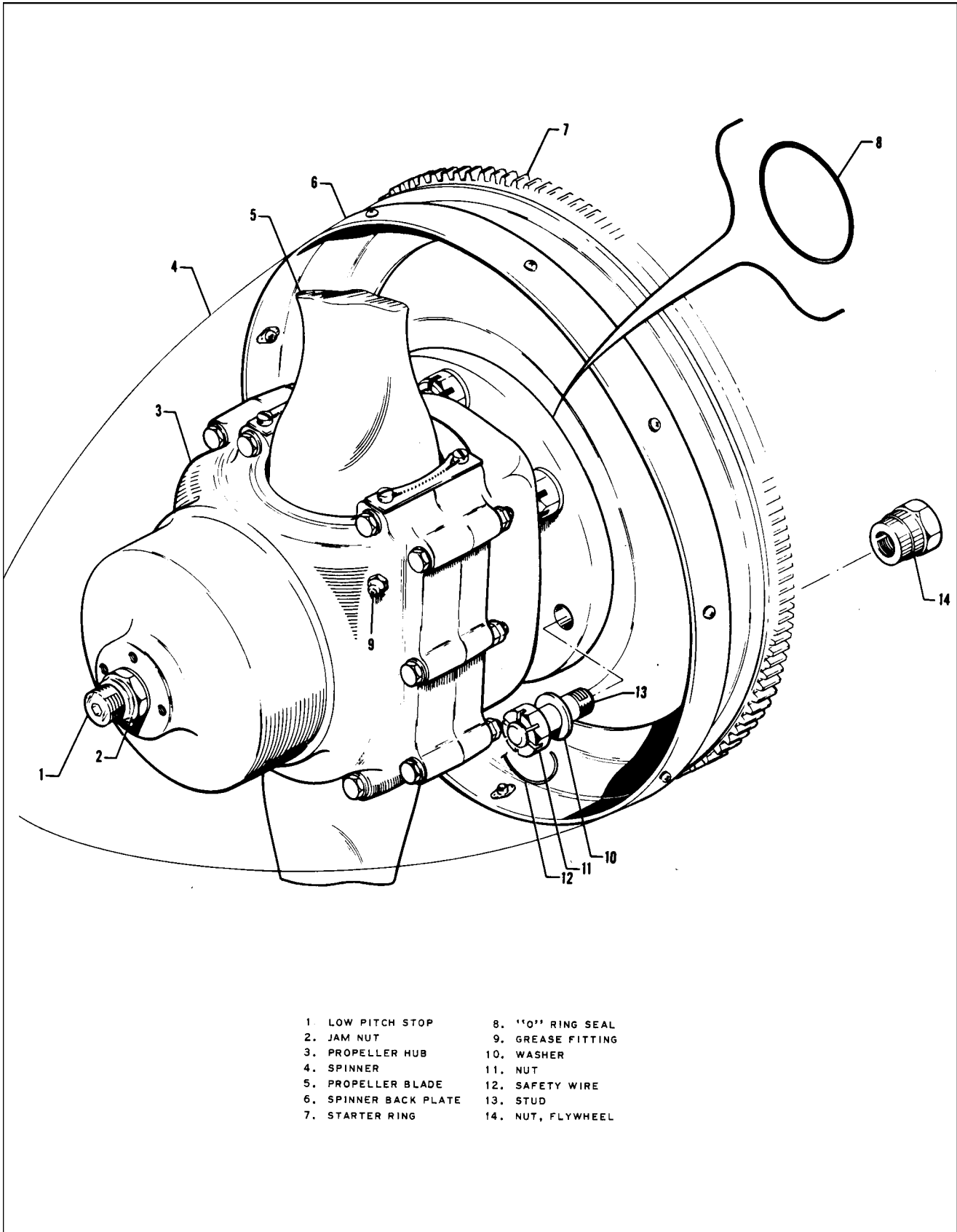

Figure 8A-1. Propeller Installation (Hartzell)

CHEROKEE ARROW III SERVICE MANUAL

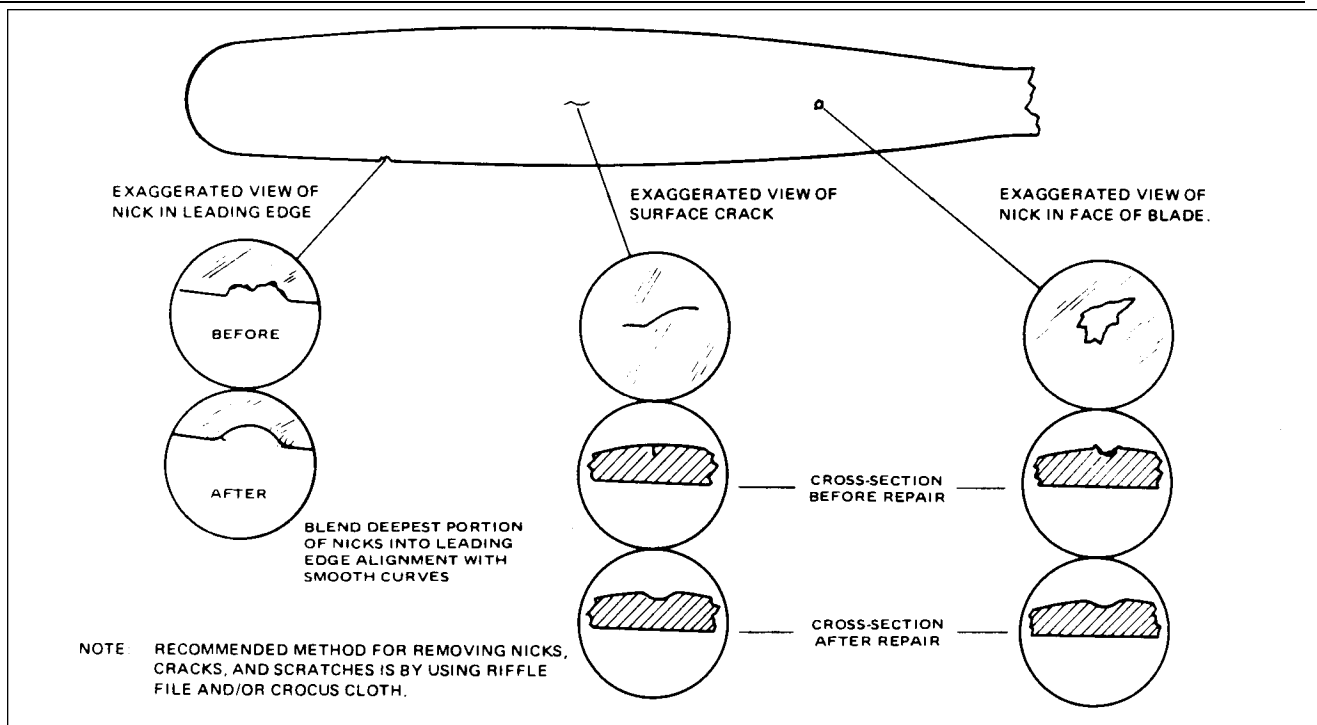

Figure 8A-2. Propeller Blade Minor Repair

NOTE

Nuts with studs will have to be backed out evenly so that propeller may be pulled forward (approx. 1/4-inch at a time) until all studs are disengaged from the engine crankshaft flange.

4. Cap engine flange to prevent contamination.

8A-6. CLEANING, INSPECTION AND REPAIR OF PROPELLER.

- a. Check for oil leaks.
- b. Clean spinner and propeller assembly with a non-corrosive solvent.
- c. Inspect spinner and propeller hub components for cracks.
- d. Check all visible components for wear and safety.
- e. Inspect blades for nicks and cracks. Refer to Figure 8A-2, for propeller blade minor repair. Nicks in leading edges of blades should be filed out and all edges rounded, as cracks sometimes start from such places. Use fine emery cloth for finishing.
- f. Hartzell propellers require grease to the blade hub through zerk fittings. Remove one of the two fittings for each propeller blade, alternate the next time. Apply grease through the zerk fitting until fresh grease appears at the fitting hole of the removed fitting. This care should be taken to avoid blowing out hub gaskets.
- g. Check for freedom of blade movement in propeller hub by rocking each blade back and forth through the slight movement allowed by the pitch change mechanism. Blades that will not allow this movement indicate internal damage.
- h. If internal or major external damage is apparent, the propeller assembly should be referred to an appropriate repair facility.
- i. Check condition of propeller mounting nuts on studs.

CHEROKEE ARROW III SERVICE MANUAL

8A-7. INSTALLING PROPELLER.

- a. Assure master switch and magneto switches are in the off position.
- b. Make certain the fuel selector is in the off position and the mixture control is in idle cut-off.
- c. Wipe crankshaft and the interior of the propeller hub to assure no foreign matter entered the propeller mechanism.
- d. Check propeller hub for proper seating of "O" ring. Cover "O" ring with a light film of engine oil.
- e. Install rear spinner bulkhead. Refer to Table VIIIA-I for torque specification.
- f. Align propeller mounting studs with proper holes and the extended bushing in the engine crankshaft flange, and slide propeller carefully over crankshaft pilot until studs can be started in crankshaft flange bushing.
- g. Secure propeller assembly by tightening the mounting studs in a sequence not to allow the propeller hub to cock on the engine crankshaft.
- h. Torque propeller mounting studs and safety. Refer to Table VIIIA-I for torque specification.
- i. Attach forward spinner bulkhead to propeller. Refer to Table VIIIA-I for torque specifications on Hartzell propellers.
- j. Attach the propeller spinner by aligning the reference mark on the spinner with the mark on the rear spinner bulkhead. Secure with attaching screws to specification. Refer to Table VIIIA-I.

8A-8. **BLADE TRACK.** Blade track is the ability of one blade tip to follow the other, while rotating, in almost the same plane. Excessive difference in blade track-more than .0625 inch-may be an indication of bent blades or improper propeller installation. Check blade track as follows:

- a. With the engine shutdown and blades vertical, secure to the aircraft a smooth board just under the tip of the lower blade. Move the tip fore and aft through its full "blade-shake" travel, making small marks with a pencil at each position. Then center the tip between these marks and scribe a line on the board for the full width of the tip.
- b. Carefully rotate propeller by hand to bring the opposite blade down. Center the tip and scribe a pencil line as before and check that lines are not separated more than .0625 inch.
- c. Propellers having excess blade track should be removed and inspected for bent blades, or for parts of sheared "O" ring, or foreign particles, which have lodged between hub and crankshaft mounting faces. Bent blades will require repair and overhaul of assembly.

8A-9. PROPELLER GOVERNOR.

8A-10. REMOVAL OF PROPELLER GOVERNOR.

- a. Remove the upper engine cowl.
- b. Disconnect the control cable end from the governor control arm.
- c. Remove the governor mounting stud nuts. It will be necessary to raise the governor as the nuts are being removed before the nuts can be completely removed.
- d. Remove the mounting gasket. If the governor is to be removed for a considerable length of time and another unit not substituted, it is advisable to cover the mounting pad to prevent damage caused by foreign matter.

8A-11. INSTALLATION OF PROPELLER GOVERNOR.

- a. Clean the mounting pad thoroughly, making very certain that there are no foreign particles in the recess around the drive shaft.
- b. Place the governor mounting gasket in position with the raised portion of the screen facing away from the engine.
- c. Align the splines on the governor shaft with the engine drive and slide the governor into position.
- d. With the governor in position, raise the governor enough to install washers and start mounting nuts. Torque nuts even.
- e. Connect the control cable end to the governor control arm. The ball stud is installed in the innerhole of the control arm.
- f. Adjust governor control per Paragraph 8A-12.
- g. Install engine cowl.

CHEROKEE ARROW III SERVICE MANUAL

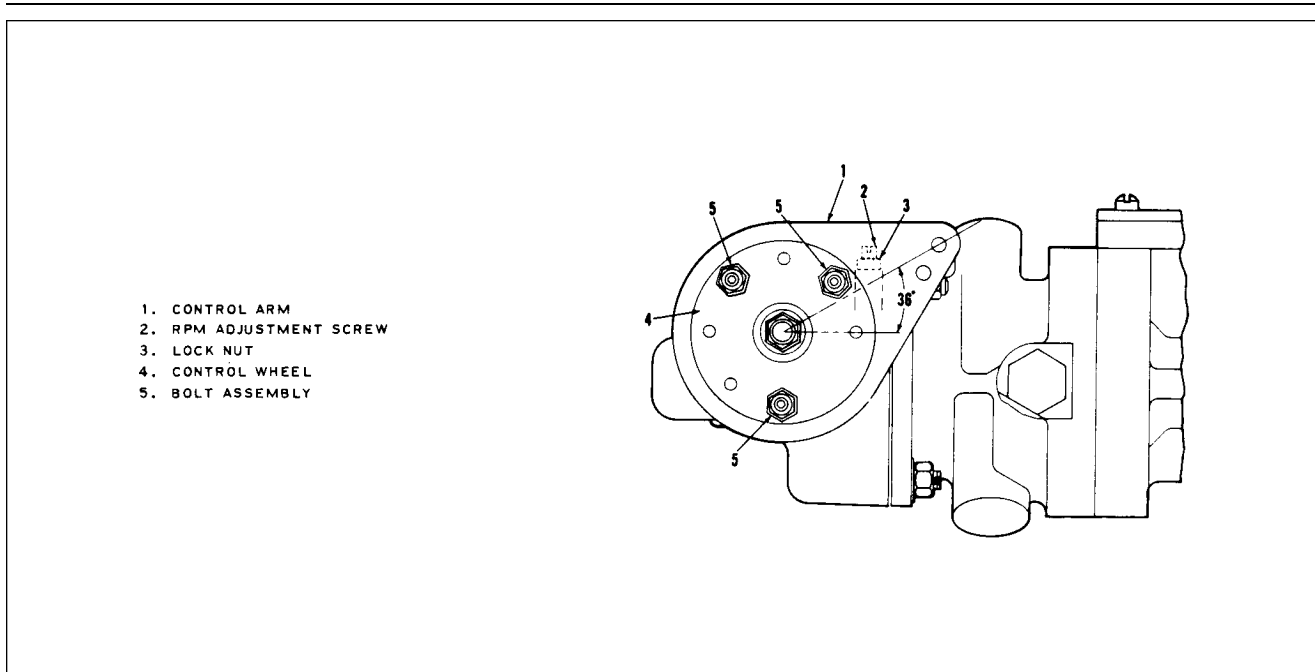

Figure 8A-3. Propeller Governor

8A-12. RIGGING AND ADJUSTMENT OF PROPELLER GOVERNOR. (Refer to Figure 8A-3.)

- a. Start engine, park 90° to wind direction and warm in normal manner.
- b. To check high RPM, low pitch setting, move the propeller control all the way forward. At this position the governor speed control arm (1) should be against the high RPM fine adjusting screw (2). With the throttle full forward, observe engine RPM, which should be 2700 RPM with high RPM properly adjusted.
- c. Should engine RPM not be as required, the high RPM setting should be adjusted as follows:
 1. Shut down the engine and remove the upper engine cowl.
 2. Adjust the governor by means of the fine adjustment screw (2) for 2700 RPM. To do this, loosen the high RPM fine adjustment screw locknut and turn the screw in a clockwise direction to decrease engine speed or in a counterclockwise direction to increase engine speed.

NOTE

One revolution of the fine adjustment screw will increase or decrease the engine speed approximately 20 RPM.

3. Reinstall upper engine cowl and repeat Step b to ascertain proper RPM setting.
 4. After setting the proper high RPM adjustment, run the self-locking nut on the fine adjustment screw against the base projection to lock.
 5. Ascertain that the governor control arm (1) is adjusted to the proper angle on the control wheel (4) as shown in Figure 8A-3.
- d. With the high RPM adjustment complete, the control system should be adjusted so that the governor control arm will contact the high RPM stop when the cockpit control knob is .032 to .047 of an inch from its full forward stop. To adjust the control knob travel, disconnect the control cable end from the control arm, loosen the cable end jam nut and rotate the end to obtain the desired level clearance. Reconnect the cable end and tighten jam nut.
 - e. It is usually only necessary to adjust the high RPM (low pitch) setting of the governor control system, as the action automatically takes care of the positive low RPM (high pitch) setting.

CHEROKEE ARROW III SERVICE MANUAL

TABLE VIIIA-I. PROPELLER SPECIFICATIONS

Blade Angle* *Measured at 30 inch station.	Low Pitch (High RPM) High Pitch (Low RPM)	Hartzell 14.0° ± 0.2° 29.0° ± 2°	McCauley 12.5° ± 0.2° 27.5° ± 0.5°
Propeller RPM Setting	Engine Static High RPM	2700 RPM Max.	
Propeller Torque Limits	Description	Required Torque (Dry)	
	Propeller Mounting Nuts	60-70 foot-pounds (Hartzell) 55-65 foot-pounds (McCauley)	
	Forward Bulkhead Attachment Bolts	30-35 inch-pounds (Hartzell)	
	Aft Bulkhead Attachment Bolts	50-70 inchpounds	
	Spinner Attachment Screws	20-25 inch pounds	

8A-13. ENGINE.

8A-13a. INSTALLATION OF BUSHINGS AND PINS FOR FIBERGLASS TYPE COWLINGS.

- a. With cowlings removed, locate bushings on lower cowling. (See Figure 8A-3a.)
- b. Using snap ring pliers, remove snap ring and old bushing.
- c. Install new bushing and new snap ring.

NOTE

Bushings should be inspected each 100 hours and should be replaced upon condition, but no later than 500 hours time in service.

- d. Locate pins in upper cowling.

NOTE

It should not be necessary to replace the pins unless bushing in lower cowling has worn enough to allow damage to the pin. Any noticeable notching or cutting of the pin requires replacement.

- e. If it is necessary to remove the pins, appropriate tools should be used to remove the fiberglass resin from around the pin and plate assembly. (A template or adequate measurements should be made to assure proper alignment of the new pin and plate assembly.)
- f. Remove pin and plate assembly
- g. To install new pin and plate assembly it will be necessary to prepare the fiberglass surface to accept the new plate. (See Paragraph 4-56, FIBERGLASS REPAIRS.)
 1. Clean area as required, and roughen.
 2. Prepare cowling surface by applying resin. Do not allow to harden.
 3. Install plate and pin.
 4. Lay in a layer of resin impregnated fiberglass cloth over the plate and surrounding fiberglass. (Use template or measurements from step e to assure alignment.) Allow to cure.

CHEROKEE ARROW III SERVICE MANUAL

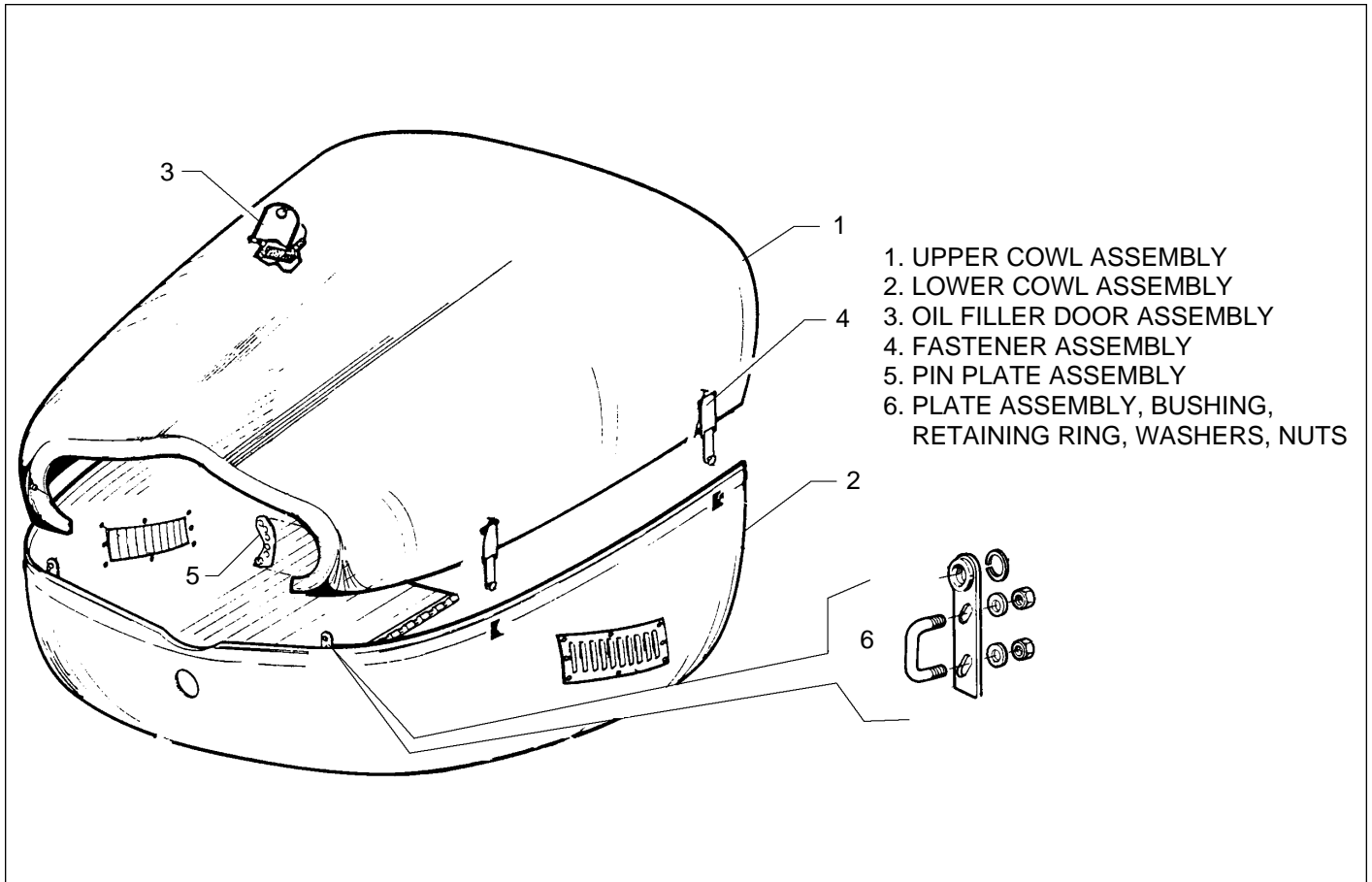

Figure 8A-3a. Engine Cowling Installation

8A-14. REMOVAL OF ENGINE.

- Turn off all electrical switches in the cockpit and then disconnect the battery ground wire at the battery.
- Move the fuel selector lever in the cockpit to OFF.
- Remove the engine cowling by the following procedure:
 - Release the cowl fasteners, two on each side of the cowl.
 - Life the aft end of the cowl and then slide it forward to release the two stud type front fasteners. Remove the top cowl.
 - Disconnect the landing light lead at the quick disconnect at the left rear side of the bottom cowl.
 - Disconnect the nose gear door rods by removing the nuts, washers, and bolts.
 - Remove the screws securing the bottom cowl at its aft end. Remove the bottom cowl.
- Remove the propeller. (Refer to Paragraph 8A-5.)
- Disconnect the starter positive and ground leads at the starter and their attachment clamps.
- Disconnect the governor control cable at the governor and cable attachment clamps.
- Disconnect the heater hose at the muffler.
- Disconnect the throttle and mixture cables at the injector. (The injector may be removed if desired.)
- Remove the air filter box by removing the bolts that secure the box to its attachment clamps. The cover may remain attached to the alternate air door control cable.
- Disconnect the fuel pump supply line at the left side of the pump. Disconnect the pump vent line.

CHEROKEE ARROW III SERVICE MANUAL

NOTE

Where a question may arise as where to reconnect hose, line or wire, the item at the separation should be identified (tagged) to facilitate reinstallation. Open fuel, oil, vacuum lines and fittings should be covered to prevent contamination.

- k. Disconnect both lines from the oil cooler.
- l. Disconnect the magneto "P" leads at the magnetos.
- m. Disconnect the engine vent tube at the engine.
- n. Disconnect the engine oil temperature lead at the aft end of the engine.
- o. Disconnect the tachometer drive cable at the engine.
- p. Untie the ignition harness, hoses and lines at the aft end of the engine.
- q. Disconnect the vacuum pump lines at pump and remove fittings from pump.
- r. Disconnect the oil pressure line at the engine.
- s. Disconnect the static and fuel flow line at the right rear engine baffle.
- t. Disconnect the manifold pressure line at the right rear side of the engine.
- u. Disconnect the injector line at the flow divider.
- v. Disconnect the alternator leads and the cable attachment clamps.
- w. Attach a one-half ton (minimum) hoist to the hoisting straps and relieve the tension from the engine mounts.

NOTE

Place a tail stand under the tail of the airplane before removing the engine.

- x. Check the engine for any attachments remaining to obstruct its removal.
- y. Drain the engine oil, if desired, and then close drain.
- z. Remove the four engine mount assemblies and swing the engine free, being careful not to damage any attaching parts.

8A-15. INSTALLATION OF ENGINE.

- a. Attach a one-half ton (minimum) hoist to the engine hoisting straps and swing the engine into alignment with its attaching points.
- b. Insert an engine mount bolt, with washer against head, in the engine mount and slide half of the mount assembly on the bolt. Repeat this procedure for the other three attachment points. (Refer to Figure 8A-4.)
- c. Position the mounting lugs of the engine so that they align with the engine mount attaching points, then move the engine rearward onto the mounts.
- d. Slide onto each mounting bolt a spacer washer, spacer and the forward half of the mount. Install washer and nut, and torque the nuts of the bolts to 450 to 500 inch-pounds.
- e. Connect the alternator leads and secure cable with clamps.
- f. Connect the injector line to the flow divider.
- g. Connect the manifold pressure line at the right rear side of the engine.
- h. Connect the static and fuel flow line at the right rear engine baffle.
- i. Connect the oil pressure line.
- j. Install the line fitting in the vacuum pump and install lines.
- k. Connect the tachometer drive cable.
- l. Connect the oil temperature lead.
- m. Connect the engine vent tube.

CHEROKEE ARROW III SERVICE MANUAL

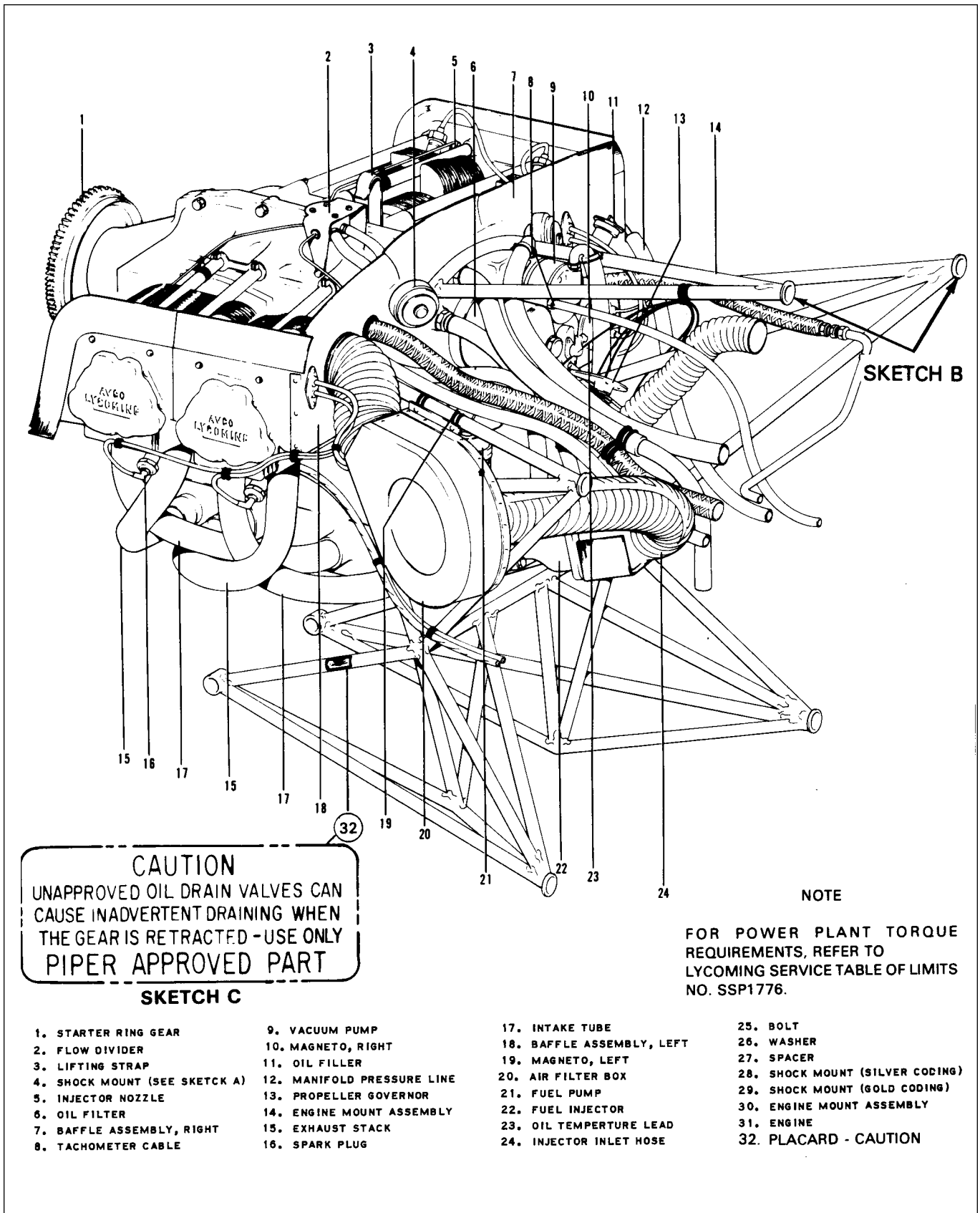
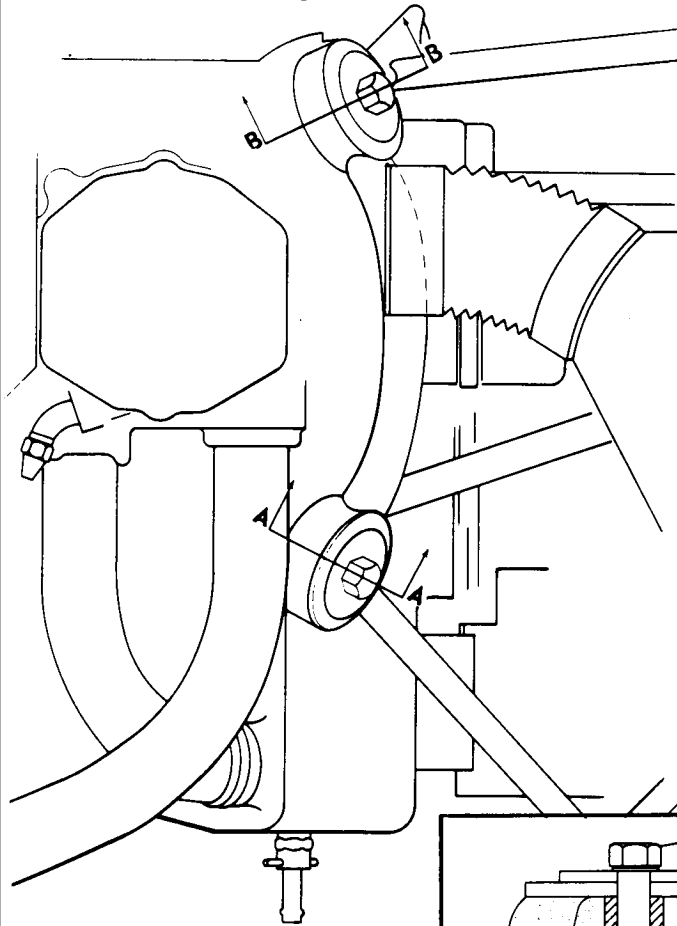

Figure 8A4. Engine Installation (PA-28R-201)

CHEROKEE ARROW III SERVICE MANUAL

CAUTION

Ground running with the cowling removed, maximum ground running is limited to **two (2) minutes** or cylinder head temperature of 450°F, whichever is reached first. Aircraft without cylinder head temperature gauge must not be operated at maximum power with cowling removed. Prolonged ground running with the cowling removed could cause local hot spots in the cylinders and irreversible engine damage.



SKETCH A

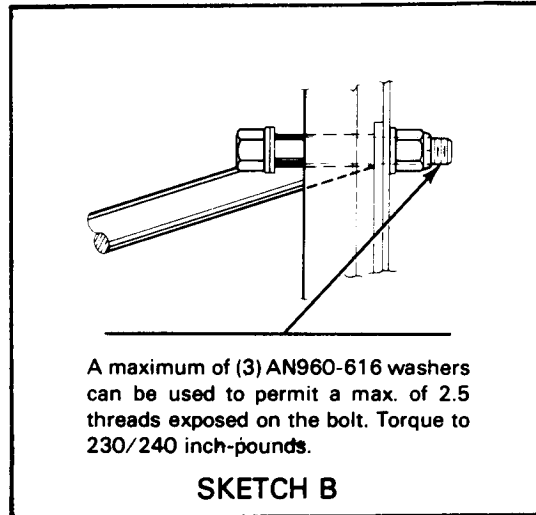

SKETCH B

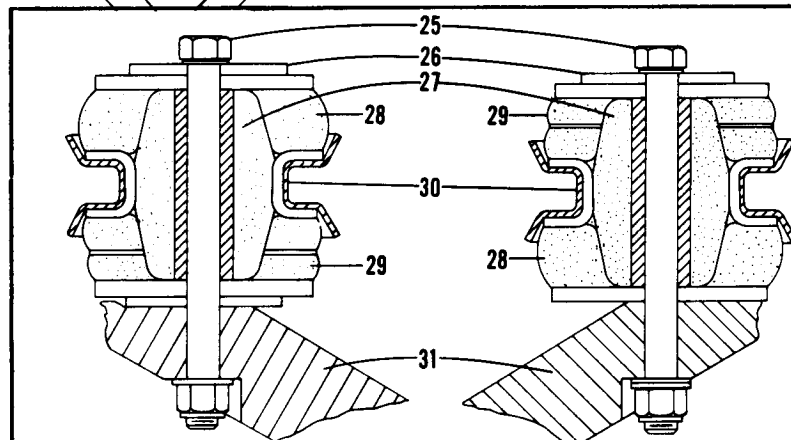

VIEW AA

VIEW BB

Figure 8A-4. Engine Installation (PA-28R-201) (cont)

CHEROKEE ARROW III SERVICE MANUAL

- n. Connect the oil cooler.
- o. Connect the magneto "P" leads. Check that magneto switch is "OFF."
- p. Connect the fuel pump supply and vent line.
- q. Install the injector.
- r. Connect the throttle and mixture cables to the injector. Check adjustment of the control by referring to Paragraph 8A-16.
- s. Connect the heater hose to the muffler.
- t. Install the air filter box, filter and box cover. Check adjustment of the alternate air door by referring to Paragraph 8A-18.
- u. Connect the governor control cable and secure with clamps.
- v. Connect the starter positive and ground leads and secure cables with clamps.
- w. Secure the ignition harness, lines, hoses, wires, etc., that may be loose.
- x. Install the propeller. (Refer to Paragraph 8A-7.)
- y. Install the cowling by attaching the bottom cowl to the firewall and then installing the top. Connect the electrical lead to the landing light.
- z. Connect the gear door retraction rods and secure with bolts, washers and nut.

NOTE

To avoid possible high speed bearing failure resulting from a lack of lubrication during initial starts, the engine should be pre-oiled in accordance with the latest revision of Lycoming Service Instruction No. 1241.

- aa. Install the proper grade and amount of engine oil.
- ab. Turn on the fuel valve; open the throttle full and turn on the electric fuel pump. Check the fuel lines for leaks.
- ac. Perform an engine operational check.

8A-15a. INSTALLATION OF OIL COOLER.

- a. When installing fittings in the oil coolers, care should be used to prevent excessive torque being applied to the cooler. When a rectangular fitting boss is provided, a backup wrench should be used, employing a scissors motion, so that no load is transmitted to the cooler. When the oil cooler has a round fitting boss, care should be taken not to permit excessive torque on the fittings.
- b. If a pipe thread fitting is used, it should be installed only far enough to seal with sealing compound.
- c. Apply Lubon No. 404 to all male pipe thread fittings; do not allow sealant to enter the system.
- d. If fitting cannot be positioned correctly using a torque of 10 to 15 foot-pounds, another fitting should be used.
- e. When attaching lines to the cooler, a backup wrench should be used.
- f. After installation, inspect the cooler for distorted end cups.
- g. Run-up engine. After run-up, check for oil leaks.

8A-16. ADJUSTMENT OF THROTTLE AND MIXTURE CONTROLS. (Refer to Figure 8A4a.) Throttle and mixture controls are adjusted so that when the throttle arm on the fuel injector is rotated forward against its full throttle stop and the mixture control is rotated forward against its full rich stop, the cockpit control levers of the throttle and mixture should have 0.010 to 0.030 of an inch spring back on instrument panel stop when in full throttle or full rich position.

- a. The throttle may be adjusted as follows:
 - 1. At the fuel injector, disconnect the rod end of the throttle control cable from the control arm. Loosen the jam nut that secures the rod end.

CHEROKEE ARROW III SERVICE MANUAL

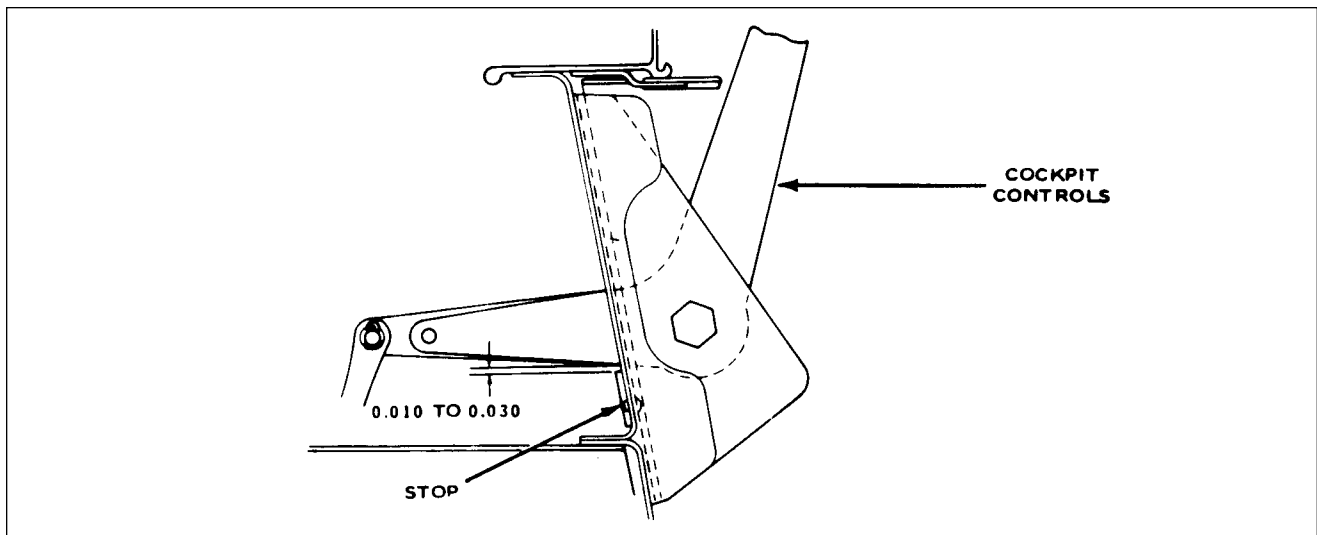

Figure 8A4a. Adjustment of Engine Controls

2. Adjust the linkage by rotating the rod end on the cable to obtain 0.010 to 0.0300 fan inch spring back on instrument panel stop when in full throttle position.
3. On aircraft equipped with air conditioning systems, a micro switch is located below the throttle control which is set to actuate in the full open position. With the throttle control adjusted to obtain a clearance of .010 to .030, adjust the micro switch to actuate at this point also.
4. Reconnect the rod end to the control arm and safety.
 - b. The mixture may be adjusted as follows:

NOTE: *Check the routing and security of the mixture cable to prevent interference between the cable and the gear linkage.*

1. At the fuel injector, disconnect the rod end of the mixture control cable from the control arm. Loosen the jam nut that secures the clevis end.
2. Adjust the linkage by rotating the rod end on the cable to obtain 0.010 to 0.030 of an inch spring back on the instrument stop when in full rich position.
3. Reconnect the rod end to the control arm and safety.
- c. Check security of cable casing attachments.
- d. Pull the throttle and mixture levers in the cockpit full aft to ascertain that the idle screw contacts its stop and the mixture control arm contacts its lean position. A mixture control lock is incorporated in the quadrant cover which prevents the mixture control from being moved to the idle cutoff position inadvertently. The lock must be depressed before the control can be moved completely aft. Ascertain that the lock operates freely without any tendency to bind or hang up.

8A-17. INDUCTION AIR FILTER.

- a. The filter should be cleaned daily when operating in dusty conditions. If any holes or tears are noticed, the filter must be replaced immediately.
- b. Remove the filter element and shake off loose dirt by rapping on a hard flat surface, being careful not to damage or crease the sealing ends.

CHEROKEE ARROW III SERVICE MANUAL

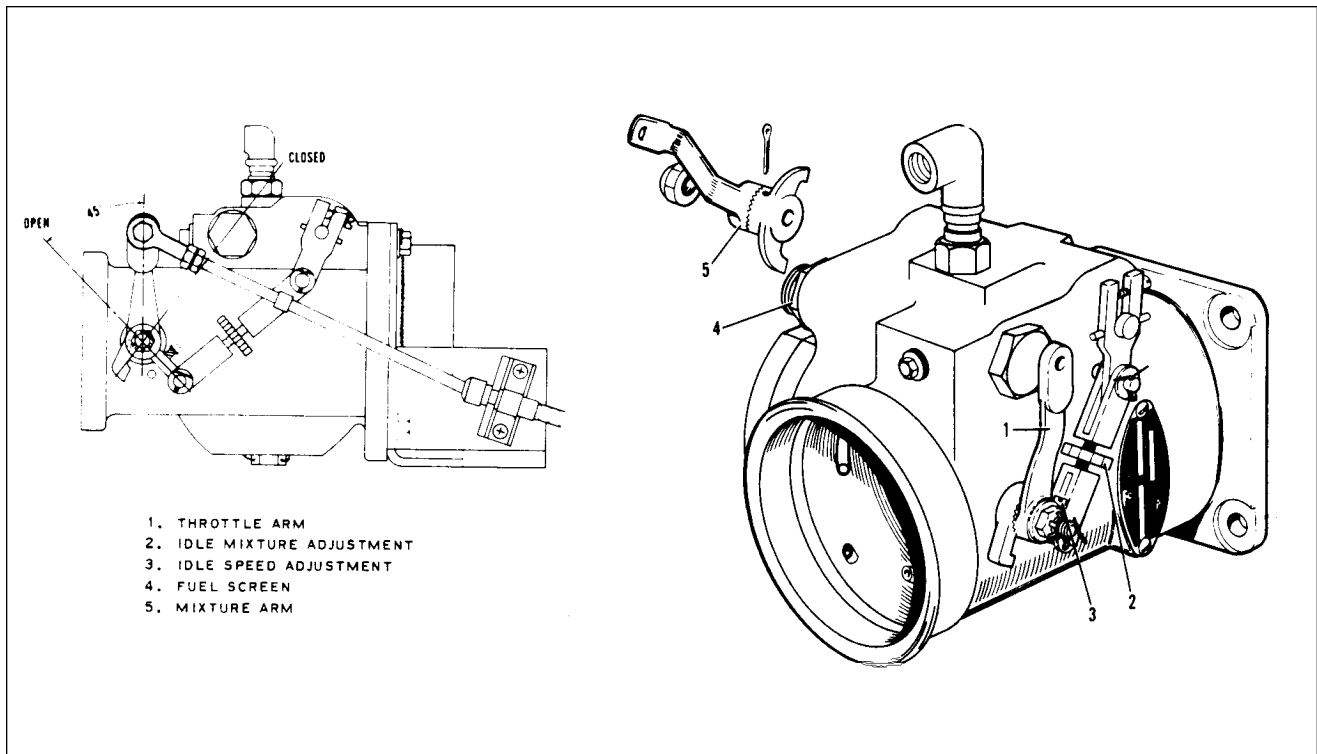

Figure 8A-5. Fuel Injector

CAUTION

Never wash the filter element in any liquid or soak it in oil. Never attempt to blow off dirt with compressed air.

- c. The filter housing can be cleaned by wiping with a clean cloth soaked in a suitable dry type solvent. When the housing is dry, reinstall and seal the filter element.

8A-18. ALTERNATE AIR DOOR. The alternate air door is located in the induction bracket mounted on the fuel injector. The door provides a source of air to the engine should there be an air stoppage through the filter system. The following should be checked during inspection:

- a. Check that air door seals are tight and hinge is secure.
- b. Ascertain that the spring tension of the door is tight enough to allow the door to remain closed at full engine RPM, yet should there be an air stoppage, it will be drawn open.
- c. Actuate the door by pushing in on it with the fingers to determine that it is not sticking or binding.
- d. Check the cockpit control cable for free travel.
- e. Check that when the control lever in the cockpit is in the open position, the cable is adjusted to allow approximately .0625 to .125 of an inch between the actuating arm roller and the door when fully closed.

8A-19. FUEL INJECTOR.

8A-20. FUEL INJECTOR MAINTENANCE.

- a. In general, little attention is required between injector overhauls. However, it is recommended that the following items be checked during periodic inspection of the engine.
 1. Check tightness and lock of all nuts and screws which fasten the injector to the engine, torquing all nuts to 135-150 inch-pounds.
 2. Seat the pal type locknuts and finger tighten them against the plain nuts. After this has been done tighten the locknuts an additional 1/3 to 1/2 turn.

CHEROKEE ARROW III SERVICE MANUAL

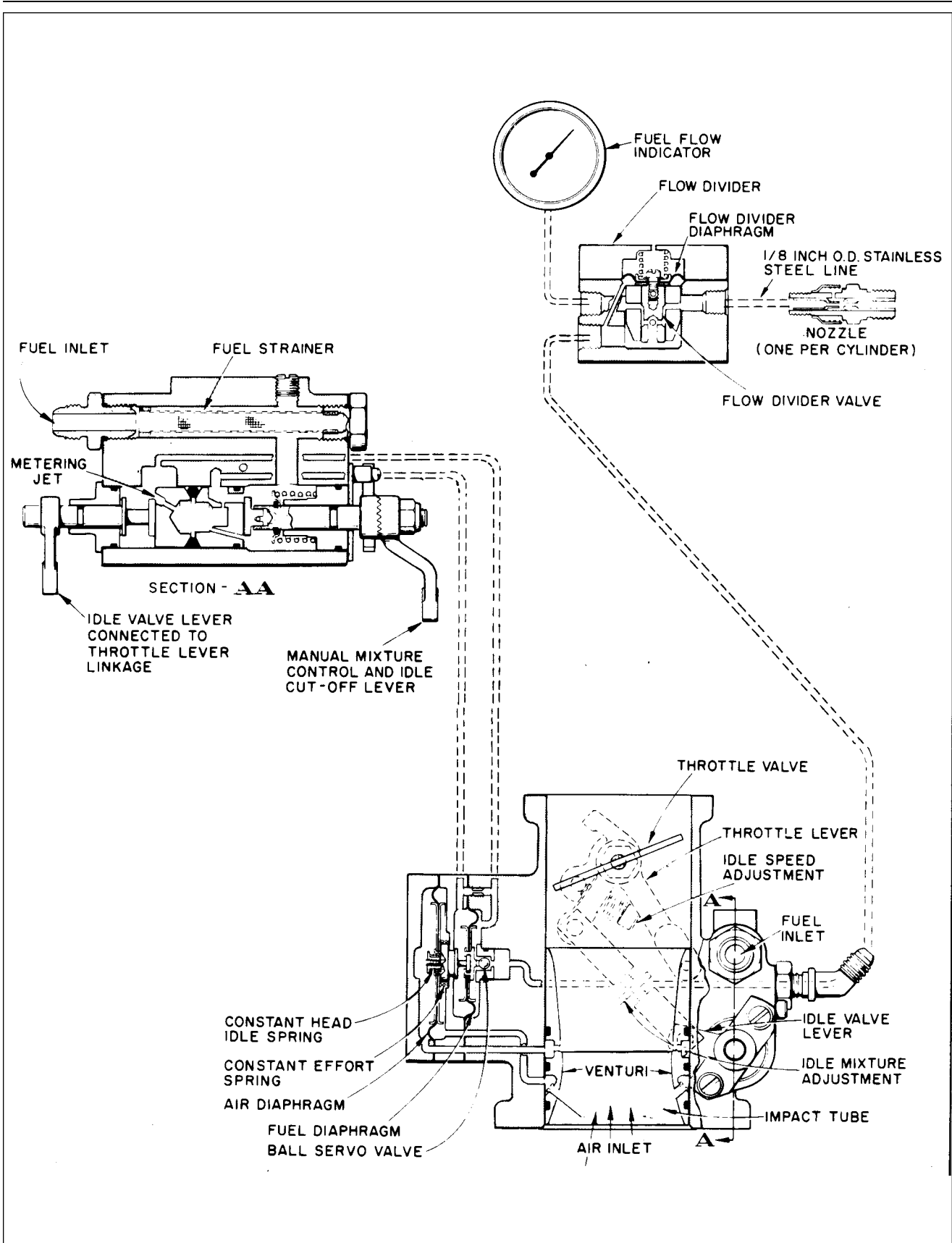

Figure 8A-6. Schematic Diagram of RSA Fuel Injection System

CHEROKEE ARROW III SERVICE MANUAL

3. Check all fuel lines for tightness and evidence of leakage. A slight fuel stain adjacent to the air bleed nozzles is not cause for concern.
4. Check throttle and mixture control rod ends and levers for tightness and lock.
5. Remove and clean the injector inlet strainer at the first 25 hours of operation and each 50 hour inspection thereafter. Check the screen for distortion or openings in the strainer. Replace for either of these conditions. Clean screen assembly in solvent and dry with compressed air. Damaged strainer "O" rings should be replaced. To install the screen assembly, place the gasket on the screen assembly and install the assembly in the throttle body and tighten to 35-40 inch-pounds torque.

8A-21. ADJUSTMENT OF IDLE SPEED AND MIXTURE.

- a. Start the engine and warm up in the usual manner until oil and cylinder head temperatures are normal.
- b. Check magnetos. If the "mag-drop" is normal, proceed with idle adjustment.
- c. Set throttle stop screw so that the engine idles at 550-600 RPM. If the RPM changes appreciable after making the mixture adjustment during the succeeding steps, readjust the idle speed to the desired RPM.
- d. When the idling speed has been stabilized, move the cockpit mixture control lever with a smooth, steady pull toward the "Idle-Cut-Off" position and observe the tachometer for any change during the leaning process. Caution must be exercised to return the mixture control to the "Full Rich" position before the RPM can drop to a point where the engine cuts out. An increase of more than 10 RPM while "leaning out" indicates an excessively rich idle mixture. An immediate decrease in RPM (if not preceded by a momentary increase) indicates the idle mixture is too lean.
- e. If the above indicates that the idle adjustment is too rich or too lean, turn the idle mixture adjustment in the direction required for correction, and check this new position by repeating the above procedure. Make additional adjustments as necessary until a check results in a momentary pick-up of approximately 5 (never more than 10) RPM. Each time the adjustment is changed, the engine should be run up to 2000 RPM to clear the engine before proceeding with the RPM check. Make final adjustment of the idle speed adjustment to obtain the desired idling RPM with closed throttle. The above method aims at a setting that will obtain maximum RPM with minimum manifold pressure. In case the setting does not remain stable, check the idle linkage; any looseness in this linkage would cause erratic idling. In all cases, allowance should be made for the effect of weather conditions and field altitude upon idling adjustment.

8A-22. FUEL-AIR BLEED NOZZLE.

8A-23. REMOVAL OF FUEL-AIR BLEED NOZZLE. The nozzles must be carefully removed as they or the cylinders may be damaged.

- a. Remove the lower engine cowl.
- b. Disconnect the fuel line from the nozzle.
- c. Carefully remove the nozzle, using the correct size deep socket.
- d. Clean and inspect the nozzle as given in Paragraph 8A-24.

8A-24. CLEANING AND INSPECTION OF FUEL-AIR BLEED NOZZLE.

- a. Clean the nozzle with acetone or equivalent and blow out all foreign particles with compressed air in the direction opposite that of fuel flow. Do not use wire or other hard objects to clean orifices. (Refer to latest revision Lycoming Service Instruction No. 1275.)
- b. Inspect the nozzle and cylinder threads for nicks, stripping or cross-threading.
- c. Inspect for battered or rounded hexagons.
- d. A test procedure for air bleed nozzles is described in latest revision Lycoming Service Instruction No. 1275.

CHEROKEE ARROW III SERVICE MANUAL

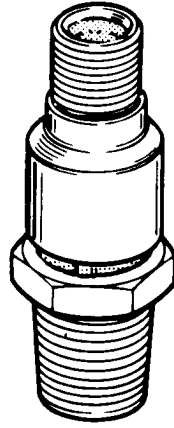

Figure 8A-7. Fuel - Air Bleed Nozzle

THIS SPACE INTENTIONALLY LEFT BLANK

CHEROKEE ARROW III SERVICE MANUAL

8A-25. IGNITION SYSTEM MAINTENANCE.

8A-26. MAGNETO.

CAUTION

Ascertain that the primary circuit of both magnetos is grounded before working on the engine.

8A-27. INSPECTION OF MAGNETO.

WARNING

When servicing or inspecting vendor equipment installed in Piper Aircraft, it is the user's responsibility to refer to the applicable vendor publication.

NOTE

Comply with latest revision of Bendix Service Bulletin No. 608 at first opportunity, but no later than next magneto overhaul. Install self-locking cam retaining screw (10-391213) and torque to 21-25 inchpounds. If self-locking screw is removed at any time always replace with new self-locking screw and torque to the specified value.

- a. After the first 25 hour and 50 hour periods, and periodically thereafter, the contact assemblies should be checked. Examine the points for excessive wear or burning. Points which have deep pits or excessively burned areas should be discarded. Examine the cam follower felt for proper lubrication. If necessary, points can be cleaned by using any hard finished paper. Clean breaker compartment with dry cloth.
- b. If engine operating troubles develop which appear to be caused by the ignition system it is advisable to check the spark plugs and wiring first before working on the magnetos.
- c. Should the trouble appear definitely associated with the magneto, the most effective measure is to install a replacement magneto which is known to be in satisfactory condition and send the suspected unit to the overhaul shop for test and repair.
- d. Should this not be possible, a visual inspection may disclose the source of trouble. Remove the harness outlet plate from the magneto. Inspect for the presence of moisture and foreign matter on the rubber grommet and high tension outlet side of the distributor block. Check height of block contact springs (0.422 maximum from top of the block tower to the spring). Also check for broken leads or damaged insulation. If either is present, remove magneto and replace with one known to be in satisfactory condition.
- e. Remove the breaker cover and harness securing screws and nuts and separate cover from magneto housing. Check contact assemblies to see that cam follower is securely riveted to its spring. Examine the contact points for excessive wear or burning. Figure 8A-8 shows how the average contact point will look when surfaces are separated for inspection. Desired contact surfaces have a dull gray, sand-blasted (almost rough) or frosted appearance, over the area where electrical contact is made. This means that points are worn in and mated to each other, thereby providing the best possible electrical contact and highest efficiency of performance.
- f. Minor irregularities or roughness of point surfaces are not harmful. (Refer to Figure 8A-8, center.) Neither are small pits or mounds, if not too pronounced. If there is a possibility of pit becoming deep enough to penetrate pad, Figure 8A-8, right, reject contact assembly.

CHEROKEE ARROW III SERVICE MANUAL

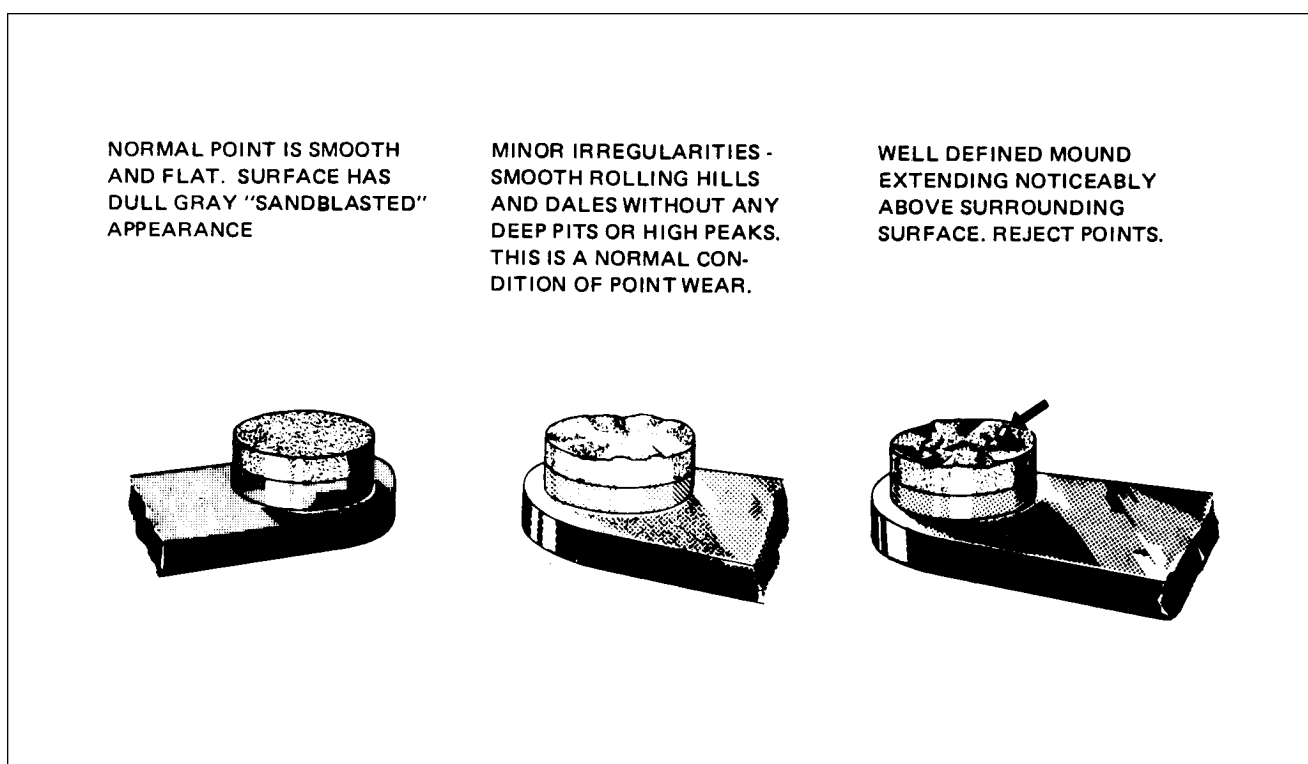

Figure 8A-8. Contact Points

NOTE

No attempt should be made to stone or dress contact points. Should contact assembly have bad points or show excessive wear, the complete contact assembly should be replaced.

- g. Check the condition of the cam follower felt. Squeeze felt tightly between thumb and forefinger. If fingers are not moistened with oil, re-oil using 2 or 3 drops of Scintilla 10-391200 lubricant. Allow approximately 30 minutes for felt to absorb the oil. Blot off the excess with a clean cloth. Too much oil may foul contact points and cause excessive burning.
- h. Check the capacitor mounting bracket for cracks or looseness. Using the Scintilla 11-1767-1, -2 or -3 Condenser Tester or equivalent, check capacitor for capacitance, series resistance and leakage. Capacitance shall be at least 0.30 microfarads.
- i. Check magneto to engine timing as follows:
 - 1. Connect Scintilla 11-851 Timing Light or equivalent across the contact assembly.
 - 2. Slowly bring the engine up to number one cylinder advance firing position as instructed in Paragraph 8A-30. At this instant the timing light should go out. If it does, the magneto is properly timed to the engine. If the timing light does not go out, removal of the magneto for internal timing check and inspection is recommended.

NOTE

The magneto service instructions in this manual are to cover minor repairs and timing. For further repairs and adjustments of the magneto, it is recommended that the manufacturer's recommended service instructions be followed.

CHEROKEE ARROW III SERVICE MANUAL

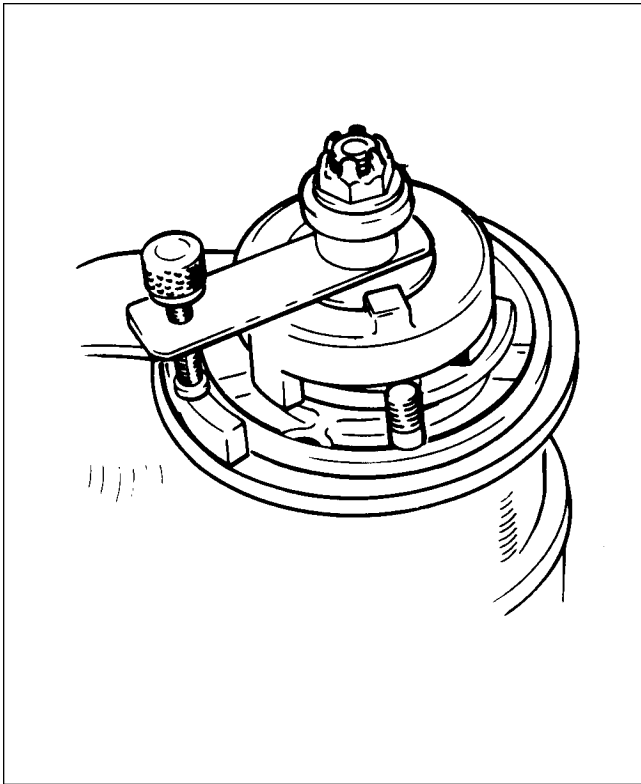

Figure 8A-9. Rotor Holding Tool Installed

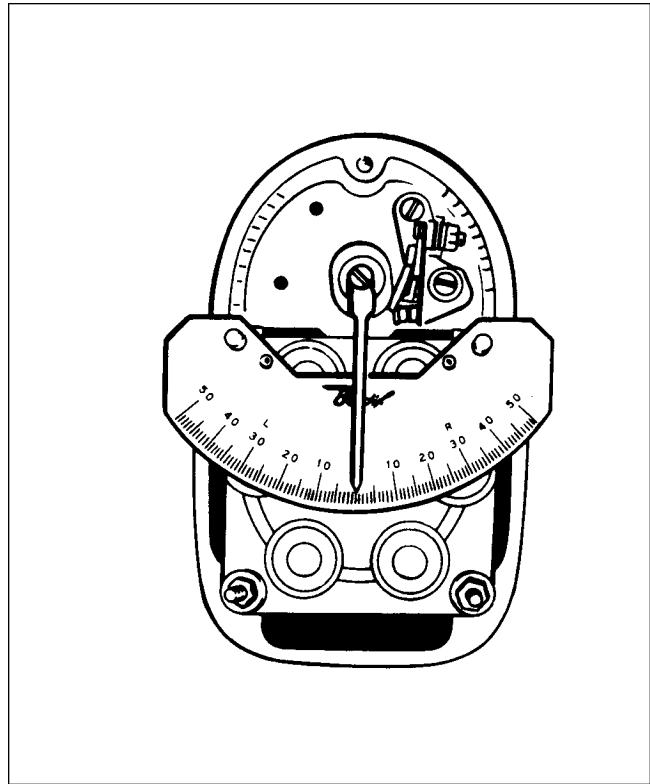

Figure 8A-10. Timing Kit Installed

8A-28. REMOVAL OF MAGNETO. Before removing the magneto, make sure magneto switches are off.

- a. Remove the harness assembly terminal plate from the magneto.

WARNING

The magneto is not internally grounded; when the ground lead is disconnected, the magneto is hot. Removing the harness assembly terminal plate first and installing them last minimizes the danger of starting the engine accidentally when the ground lead is removed from the magneto.

- b. Disconnect the ground lead at the magneto.
- c. Remove the nuts and washers and draw the magneto from the engine.

8A-29. TIMING PROCEDURE (INTERNAL TIMING).

- a. Remove the cover to the contact(s), distributor block, etc.
- b. To internally time the contact assembly of the single-breaker magnetos, proceed as follows:
 1. Loosen the nut securing the drive plate to the magneto shaft sufficiently in order to install the Scintilla 11-8465 Rotor Holding Tool under the nut and flat washer as shown in Figure 8A-9. Tighten the nut securely.
 2. Remove the timing inspection plug from the top of the magneto. Turn rotating magneto to proper neutral position. This position is determined by locating keyways on drive end of magnet shaft at 12 o'clock with respect to name plate on housing. Tighten adjusting knob of 11-8465 Rotor Holding Tool until pressure is applied on housing flange preventing magnet from turning.
 3. Loosen and rotate cam until cam follower of contact assembly rests on highest point of cam lobe. Adjust contact assembly to obtain the clearance of 0.016 of an inch. Tighten contact assembly securing screws to 20-25 inch-pounds.

CHEROKEE ARROW III SERVICE MANUAL

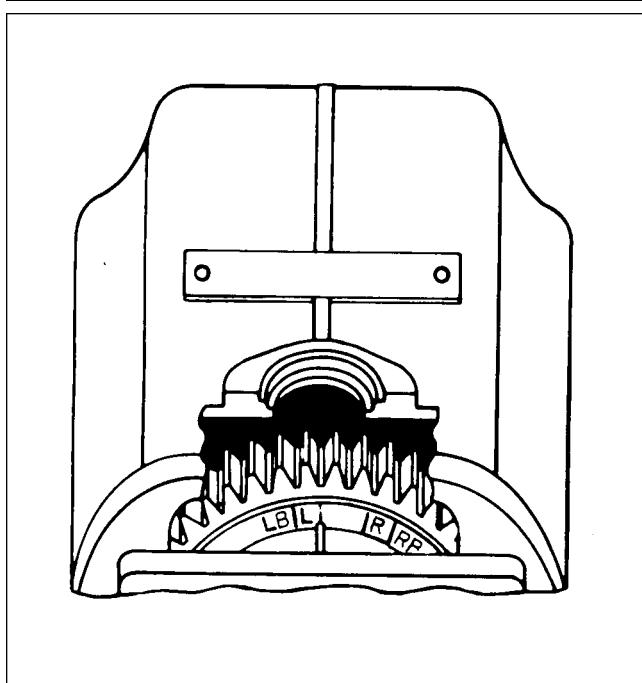

Figure 8A-11. Aligning Timing Marks

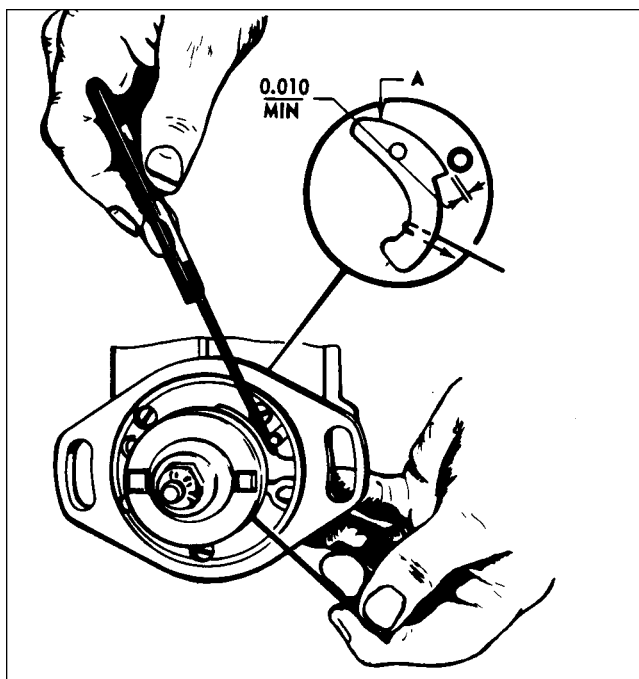

Figure 8A-12. Checking Flyweight Clearance of Impulse Coupling

4. Install the 11-8693 Timing Plate Assembly and the 11-8149 Pointer Assembly of the 11-8150 Scintilla Timing Kit to breaker compartment of magneto. (Refer to Figure 8A-10.) Align pointer assembly with the 0 mark on timing plate. Loosen adjusting knob of 11-8465 Rotor Holding Tool and turn rotating magnet in normal direction of rotation until pointer indexes with the respective E gap mark ($15^\circ \pm 2^\circ$). Tighten adjusting knob of 11-8465 Tool and remove the 11-8149 Pointer Assembly from magneto. Using a timing light, adjust contact points to just open. This adjustment shall be made by rotating cam, in opposite direction of rotation until contacts just open. While holding cam in this exact position, push cam on magnet shaft as far as possible with the fingers. Extreme care must be exercised in this operation. If cam adjustment is changed in the slightest degree, the timing of the magneto will be thrown off. Do not drive cam on shaft with a mallet or other instrument. Tighten the securing screw thereby drawing the cam down, evenly and tightly. Torque screw to 16-20 inch-pounds. Loosen the 11-8465 Rotor Holding Tool adjusting knob and return rotating magnet to neutral position. Reinstall the 11-8149 Pointer Assembly over 0 mark on timing plate. Rotate magnet shaft in normal direction of rotation and check for opening of main contact points at E gap setting ($15^\circ \pm 2^\circ$).
- c. If the distributor block was not removed from the housing, the internal timing may be checked by turning the magneto in the normal rotation to number one firing position (keyway up and points just opening). At this position, the reference line on the distributor block should line up between the L and LB marks on the gear. On single contact magnetos the line should favor the L mark, if possible.
- d. If the distributor block was removed from the housing, the distributor gear alignment and internal check may be accomplished as followed:
 1. Turn rotating magnet in direction of rotation until it is located in firing position (keyway up and points just opening). Tighten adjusting knob of 11-8465 Rotor Holding Tool. Apply a light coating of Bendix Grease P/N 10-27165 to teeth of distributor gear, if needed. The large distributor gear incorporates four timing marks, L and LB for left-hand rotation and R and RB for right-hand rotation.
 2. With distributor gear assembled to block, turn gear until raised rib on block lines up between the L and LB marks. Assemble block and gear into housing, meshing the distributor gears together. The rib should favor the L mark, if possible. (Refer to Figure 8A-11.)

CHEROKEE ARROW III SERVICE MANUAL

3. Secure distributor block to housing with studs and washers. Tighten studs finger tight. Loosen the 11-8465 Rotor Holding Tool and turn rotating magnet in reverse direction of rotation until timing light indicates contact assembly had just opened and check to make certain timing marks align within tolerance indicated above. Tighten block securing studs, first to 4-8 inch-pounds torque and then final torque to 20 inch-pounds.
4. Insert the tip of your small finger through timing hole in housing and against large distributor gear teeth. Rock distributor gear back and forth slightly. There must be perceptible backlash between teeth of large and small gears. This check should be made at three different points, 120° apart on gear. If backlash is not evident, replace large distributor gear.
5. Install the breaker cover and complete reassembly of the magneto. Refer to the manufacturer's publications for complete disassembly and reassembly procedures.
- e. On the magneto employing the impulse coupling, check clearance between each flyweight and each stop pin as follows:
 1. Bend the end of a stiff piece of wire into a right angle 1/8 inch long (maximum).
 2. Hold magneto as shown in Figure 8A-12. Pull heel of flyweight outward with the hooked wire and make certain that feeler gauge of 0.010 inch minimum thickness will pass between stop pin and the highest point of the flyweight.

NOTE

A true and accurate check of the clearance between flyweight and stop pin can only be obtained by pulling the flyweight outward as described above. Do not attempt the check by pushing in on flyweight at point "A."

- f. Install and time magneto, removed from engine, in accordance with Paragraph 8A-30.
- g. Secure external switch leads to the breaker cover terminals. Connect harness assembly to the magneto.

8A-30. INSTALLATION AND TIMING PROCEDURE (TIMING MAGNETO TO ENGINE). Although only the left magneto is equipped with an impulse coupling, the timing procedure, in the following paragraphs, is the same for both magnetos.

- a. Remove the spark plug from No. 1 cylinder and place a thumb over the spark plug hole. Rotate the crankshaft in direction of normal rotation until the compression stroke is reached, this is indicated by a positive pressure inside the cylinder tending to push the thumb off the spark plug hole. Continue rotating the crankshaft in direction of normal rotation until the advance timing mark (25) on the front face of the starter ring gear is in exact alignment with the small hole located at the two o'clock position on the front face of the starter housing. (Refer to Figure 8A-13.)

NOTE

The advance timing mark on the top face of the starter ring gear is marked at both 20° and 25° BTC. Use only the 25° BTC mark when timing the magnetos to the engine.

NOTE

If the crankshaft is accidentally turned in the direction opposite normal rotation, repeat the above procedure as accumulated backlash will make the final timing incorrect.

CHEROKEE ARROW III SERVICE MANUAL

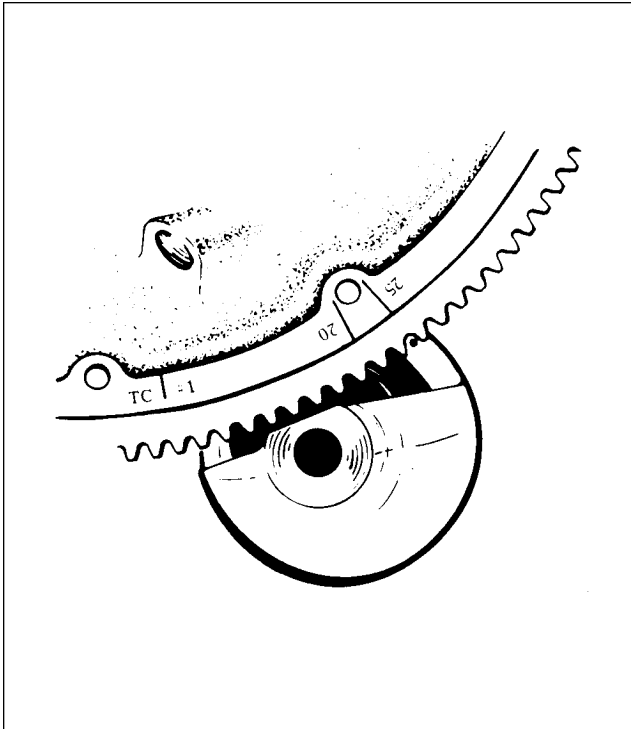

Figure 8A-13. Engine Timing Marks

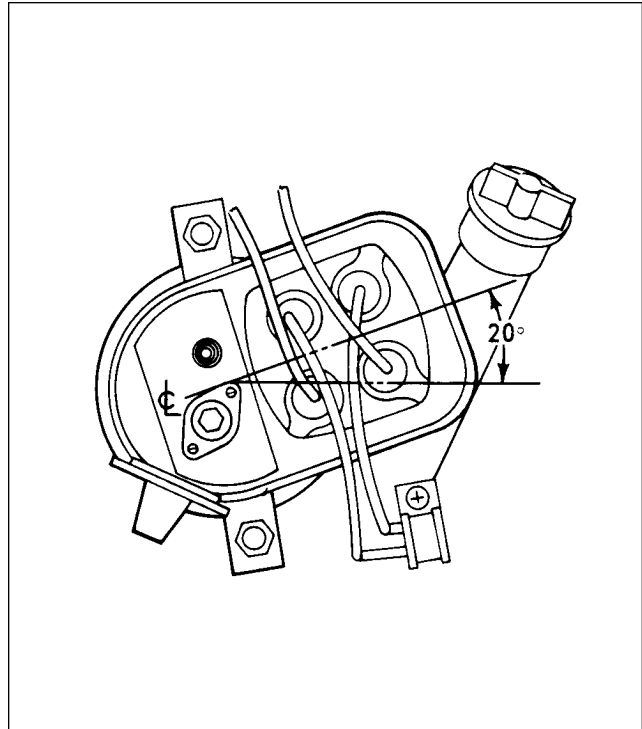

Figure 8A-14. Magneto Adjustment Limits

- b. At this point, the engine is ready for assembly of the magnetos. Remove the inspection plugs from both magnetos and turn the drive shafts in direction of normal rotation (counterclockwise facing the coupling), until the first painted chamfered tooth on the distributor gear is aligned in the center of the inspection window. (Refer to Figure 8A-15.) Being sure that the gear does not move from this position, install gaskets and magnetos on the engine. Secure with washers and nuts; tighten only finger tight.

NOTE

The magnetos are held in place by clamps which allows them to be timed in several positions. Since all positions will not give the required clearance between magneto and engine mount, the magnetos must be installed from the horizontal position to 20° above the horizontal as shown in Figure 8A-14. Improper installation of magnetos could cause damage or failure.

NOTE

In order to turn the shaft on an impulse coupling magneto, depress pawl on the impulse coupling with the finger.

- c. Using a battery powered timing light, attach the positive lead to a suitable terminal connected to the ground terminal of the magneto and the negative lead to any unpainted portion of the engine. Rotate the magneto in its mounting flange to a point where the light comes on, then slowly turn it in the opposite direction until the light goes out. Bring the magneto back slowly until the light just comes on. Repeat this with the second magneto.

NOTE

AC timing lights operate in the reverse manner as described above; the light goes out when the breaker points open.

CHEROKEE ARROW III SERVICE MANUAL

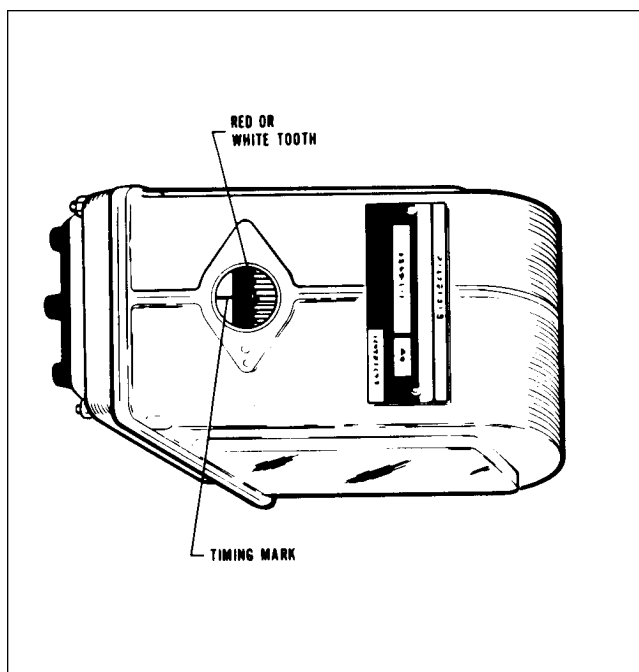

Figure 8A-15. Magneto Timing Marks

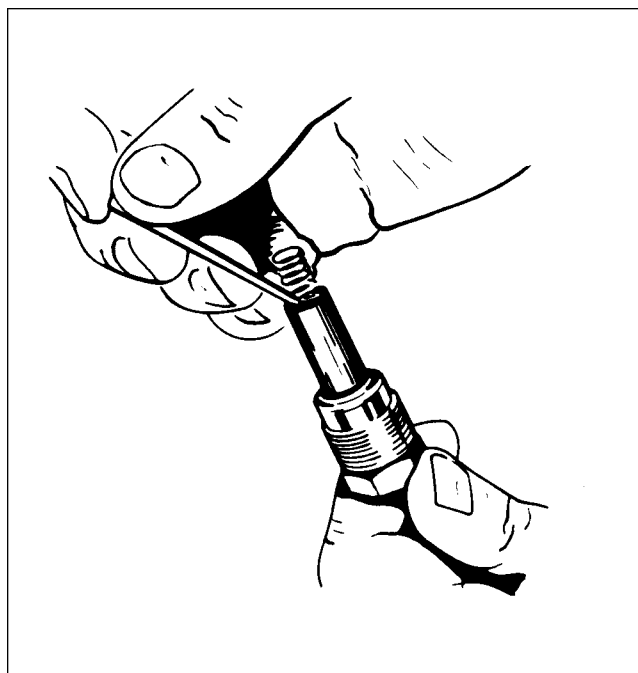

Figure 8A-16. Removing Spring From Lead Assembly

- d. After both magnetos have been timed, check, as described below, to ascertain that both magnetos are set to fire together.
- e. Back off the crankshaft a few degrees; the timing lights should go out. Bring the crankshaft slowly back in direction of normal rotation until the timing mark and the hole in the starter housing are in alignment. At this point, both lights should go on simultaneously. Tighten nuts to specified torque.
- f. After magnetos have been properly timed, replace breaker cover and secure.
- g. Install the ground lead and the retard spark lead on the left magneto.
- h. Place the harness terminal plate on the magneto and tighten nut around the plate alternately to seat cover squarely on magneto. Torque nuts to 18 to 22 inch-pounds.

8A-31. HARNESS ASSEMBLY.

8A-32. INSPECTION OF HARNESS.

- a. Check lead assemblies for nicks, cuts, mutilated braiding, badly worn section or any other evidence of physical damage. Inspect spark plug sleeves for chafing or tears and damaged or stripped threads on coupling nuts. Check compression spring to see if it is broken or distorted. Inspect grommet for tears. Check all mounting brackets and clamps to see that they are secure and not cracked.
- b. Using an ohmmeter, buzzer, or other suitable low voltage device, check each lead for continuity. If continuity does not exist, wire is broken and must be replaced.
- c. For electrical test of harness assembly, use a high voltage, direct current tester such as the TAKK Model 86 or 86A or an equivalent direct current high voltage tester capable of delivering a test potential of 10,000-volts. Connect ground lead to high voltage tester to outer shielding braid of a single lead. Connect plug terminal. Turn tester "ON" and apply 10,000-volts. The insulation resistance should be 100 megohms minimum. Proceed to check other leads of harness in same manner.
- d. Minor repair of the harness assembly, such as replacement of contact springs, spring retainer assemblies, insulating sleeves or of one lead assembly, can be accomplished with the harness assembly mounted on the engine. However, should repair require replacement of more than one lead assembly or of a cable outlet plate, the harness should be removed from the engine and sent to an overhaul shop.

CHEROKEE ARROW III SERVICE MANUAL

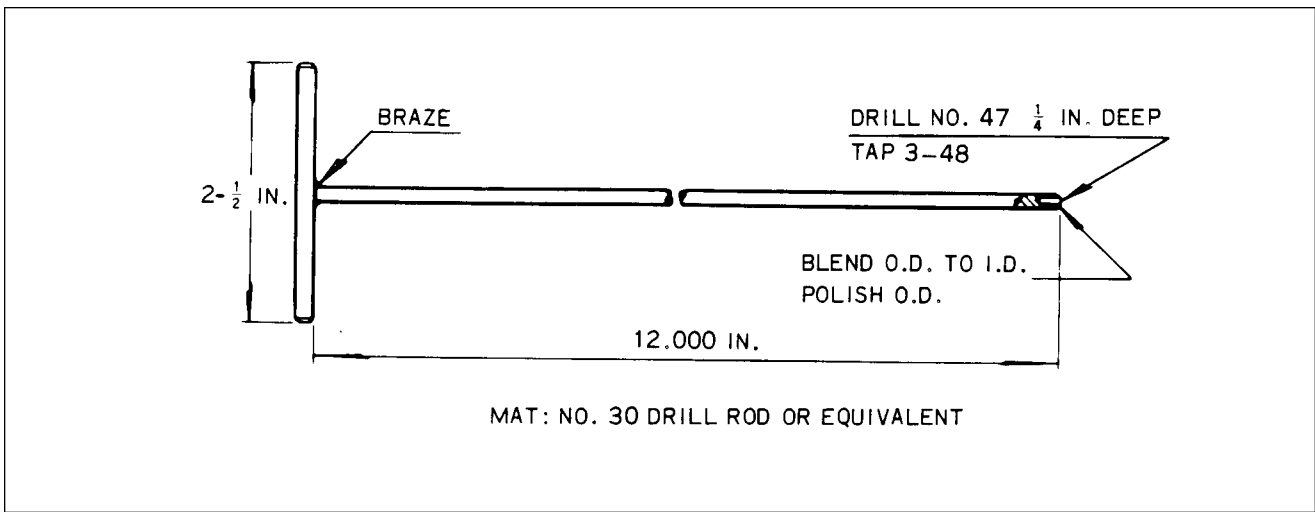

Figure 8A-17. Assembly Tool

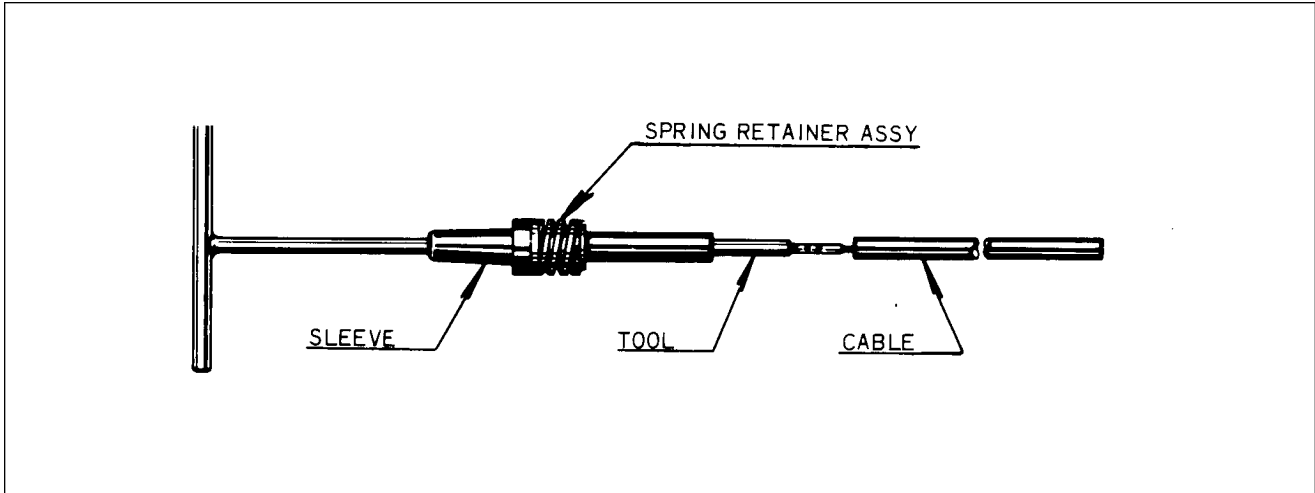

Figure 8A-18. Using Assembly Tool

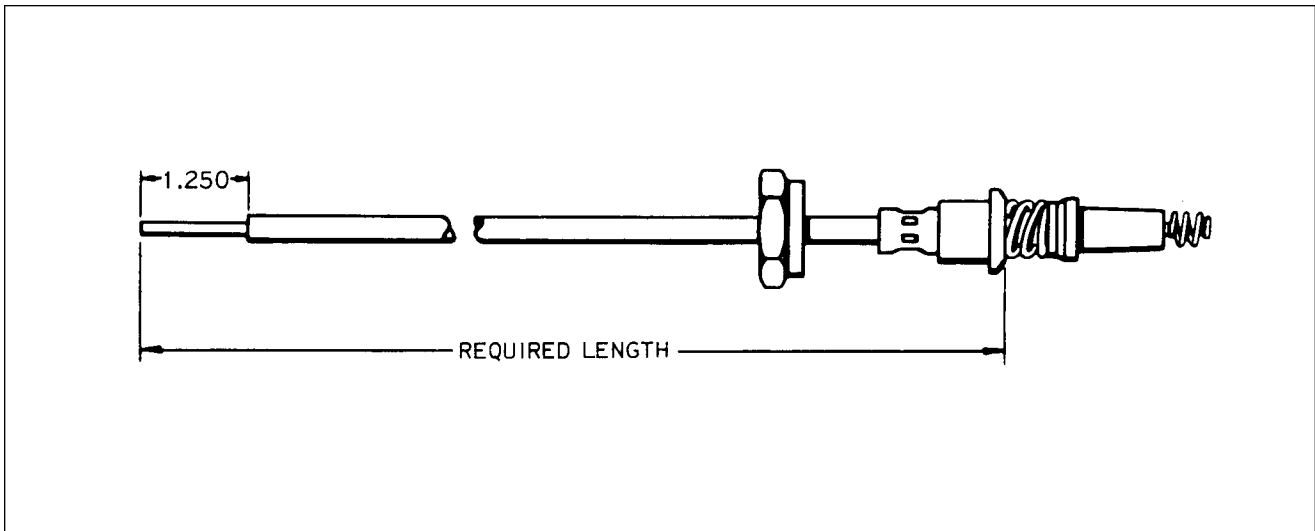

Figure 8A-19. Measuring Lead Assembly Length

CHEROKEE ARROW III SERVICE MANUAL

8A-33. REMOVAL OF HARNESS.

- a. Disconnect the clamps that secure the wires to the engine and accessories.
- b. Loosen the coupling nuts at the spark plugs and remove the insulators from the spark plug barrel well. Use caution when withdrawing the insulator not to damage the insulator spring.
- c. Place a guard over the harness insulators.
- d. Remove the harness assembly terminal plate from the magneto.
- e. Remove the harness from the airplane.

8A-34. MAINTENANCE OF HARNESS.

- a. To replace contact springs, spring retainer assemblies or insulating sleeves, proceed as follows:
 1. Using a Scintilla 11-7073 Needle or a mechanical pencil with the lead retracted, hook the end of the contact spring as shown in Figure 8A-16.
 2. Using the needle or pencil, unscrew the spring.
 3. Slide insulating sleeve and spring retainer assembly off end of lead assembly.
 4. Replace defective component and reassemble as follows:
 - (a) Fabricate a tool as shown in Figure 8A-17 for installing the insulating sleeves over cable terminals.
 - (b) Push the tool through insulating sleeve and spring retainer assembly as shown in Figure 8A-18. Screw the cable terminal into the tool.
 - (c) Work insulating sleeve and spring retainer assembly into position over the cable and unscrew the tool. Install contact spring on cable terminal.

NOTE

It may be necessary to lubricate cable and insulating sleeve with a thin firm of MC 200 (200,000 centistokes) or commercial grade alcohol to facilitate assembly.

- b. To replace one of the lead assemblies, proceed as follows:
 1. Remove clamps and brackets from applicable lead assembly. Cut cable ties from assembly and discard.
 2. Cut off condemned lead flush with outer surface of cable outlet plate.
 3. Grip eyelet of lead with a pair of pliers and pull short length of conductor out of grommet and cable outlet plate.
 4. Using a 3 inch long, 0.270 inch diameter drift, applied at outer surface of plate, drive out tapered ferrule and remaining pieces of insulation and shielding.
 5. To determine what length the new lead assembly should be cut to, proceed as follows:
 - (a) Measure the length of the condemned lead assembly. Move coupling nut back on lead assembly and measure from outer end-of ferrule at spark plug end. (Refer to Figure 8A-19.)
 - (b) To the length determined in Step (a), add 1-3/4 inches.

NOTE

Spare part leads are supplied in various lengths. Use a lead which is longer than, but nearest to, the desired length.

CHEROKEE ARROW III SERVICE MANUAL

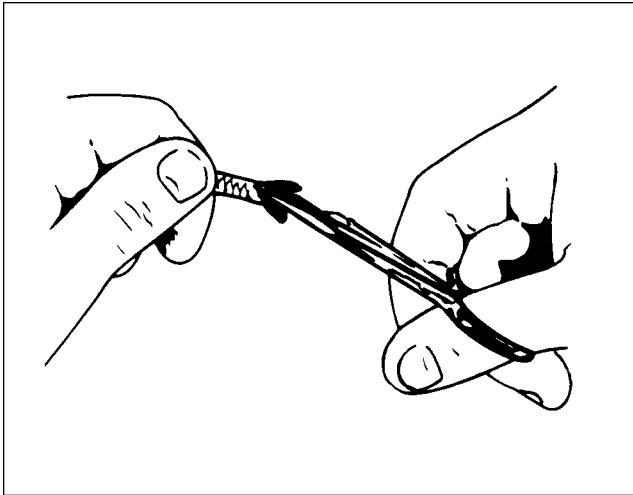

Figure 8A-20. Cutting Metallic Braid From End of Lead

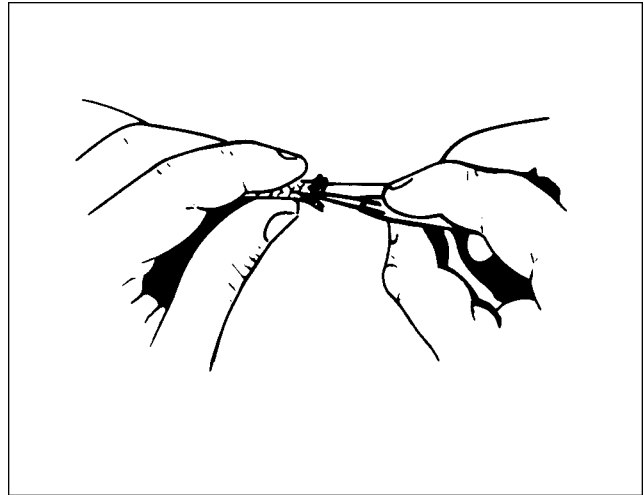

Figure 8A-21. Unbraiding Metallic Shielding

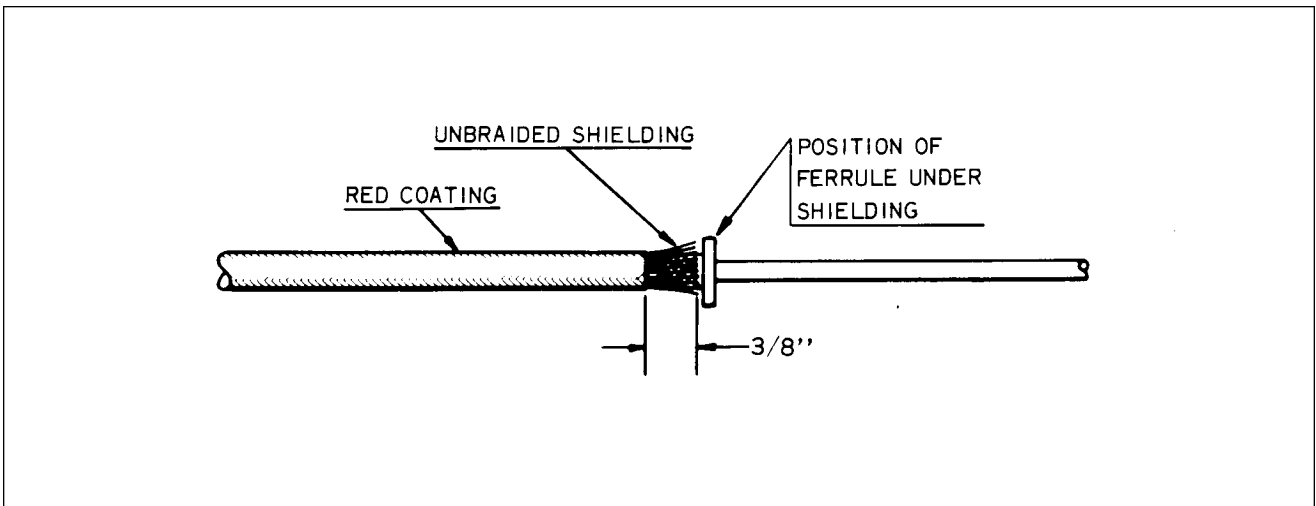

Figure 8A-22. Forming Shielding Around Ferrule

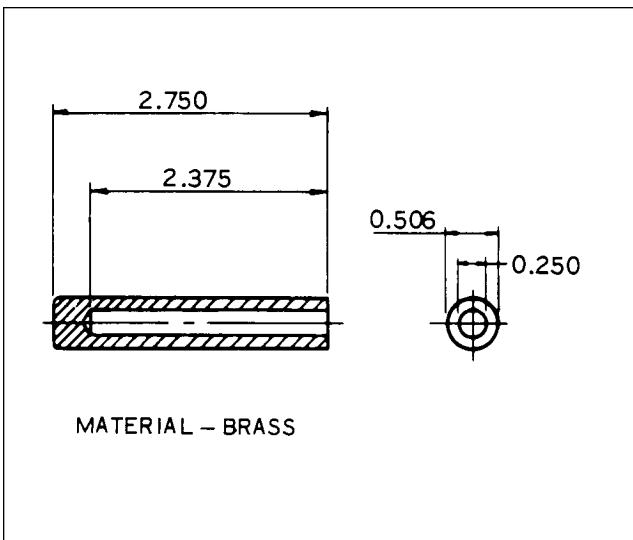

Figure 8A-23. Ferrule Seating Tool

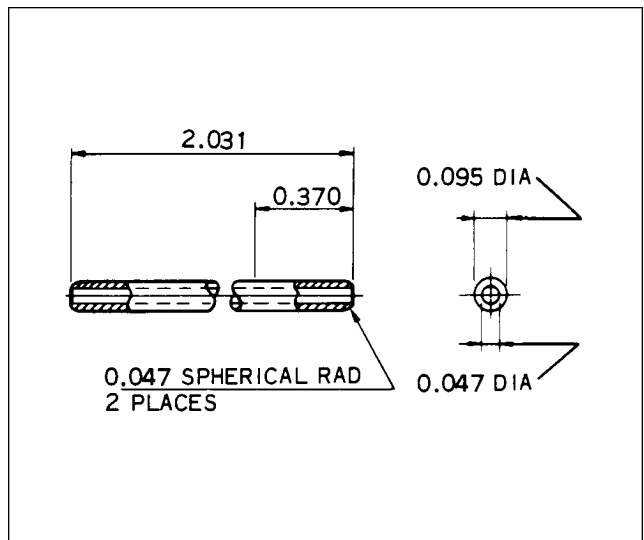

Figure 8A-24. Needle

CHEROKEE ARROW III SERVICE MANUAL

6. Cut lead assembly to the length determined in Step 5. Mark ferrule on spark plug end of lead with a metal stamp, scribe or rubber stamp to correspond with correct cylinder number.
7. Starting at spark plug location, thread new cable through grommets and clamps as necessary for correct routing of cut end of cable to magneto location.
8. Using electrician's scissors, carefully remove 1.250 inch of outer braid from end of lead. (Refer to Figure 8A-20.)

CAUTION

Use care not to nick or cut insulation when removing braid.

9. Using a scribe or similar pointed tool, unbraid 3/8 inch of braided shielding. (Refer to Figure 8A-21.) Wrap a single thickness of electrical tape around unbraided strands to facilitate insertion of lead end through hole in cable outlet plate.
10. Remove cable outlet plate from magneto. Support plate securely and, using suitable cutting pliers, split and remove eyelets from leads adjacent to lead being replaced. When splitting eyelet make certain that wire strands are not cut. Removal of eyelets on adjacent leads will allow grommet to be pulled away from outlet plate to facilitate insertion of new lead.
11. Pass the taped end of new lead through hole in outlet plate. Remove electrical tape from lead and install tapered end of ferrule under the unbraided strands of shielding. Form strands of shielding evenly as shown in Figure 8A-22 and pull lead assembly back through cable outlet plate until ferrule binds in the outlet well. Position the Scintilla 11-7074 Ferrule Seating Tool (Figure 8A-23) over the wire and firmly seat the ferrule by tapping the seating tool with a hammer or by using an arbor press.
12. Measure 1/2 inch from tapered ferrule and strip remaining insulation from wire. (Refer to Figure 8A-25.)
13. Insert Scintilla 11-7073 Needle (Figure 8A-24) through small hole of grommet and over stripped end of wire. (Refer to Figure 8A-26.) Slide grommet down needle until it seats tightly against the tapered ferrule.
14. Cut wire 3/8 inch from top of grommet outlet. (Refer to Figure 8A-27.) Double wire over as shown in A of Figure 8A-28. Slide eyelet over doubled wire until it is firmly seated in recess of grommet outlet.
15. Using the "AB" groove of Scintilla 114152 Crimping Tool, or equivalent, crimp eyelet to wire. Approximately 1/32 of an inch of wire should extend from end of eyelet after crimping. (Refer to B of Figure 8A-28.)

NOTE

If the crimping tool is not available, a satisfactory connection can be made by soldering with Kester Flux 709 or equivalent and a non-corrosive solder. After soldering, clean solder joints using denatured alcohol.

16. Install clamps and cable ties as necessary to secure lead to the engine.

CHEROKEE ARROW III SERVICE MANUAL

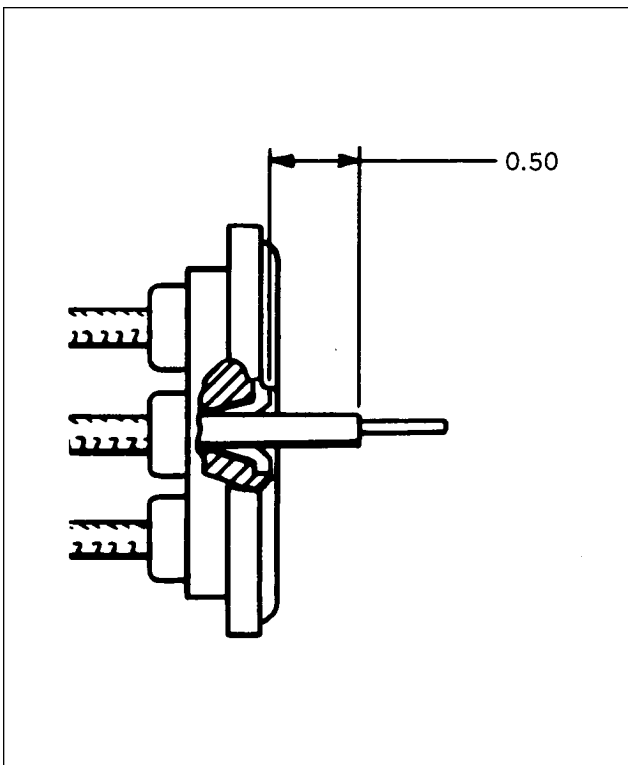

Figure 8A-25. Measuring Wire From Top of Ferrule

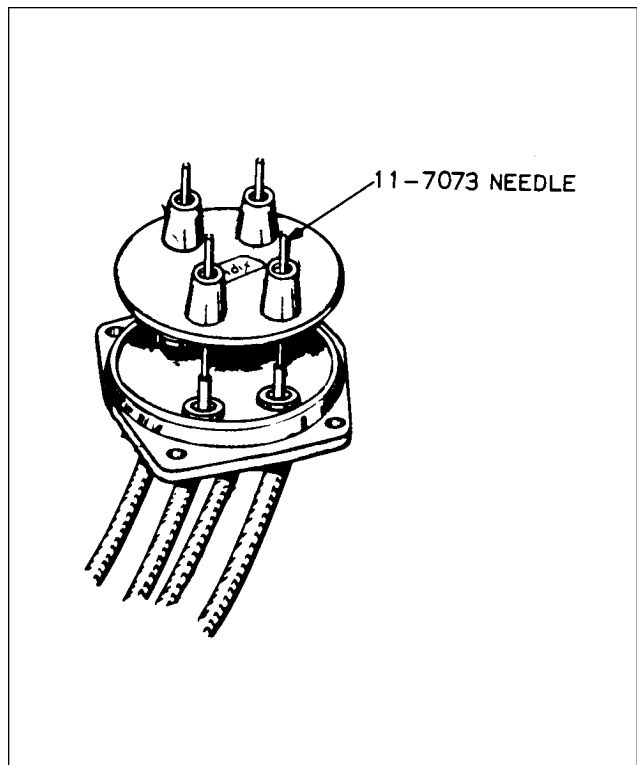

Figure 8A-26. Installing Grommet Over Lead Assemblies

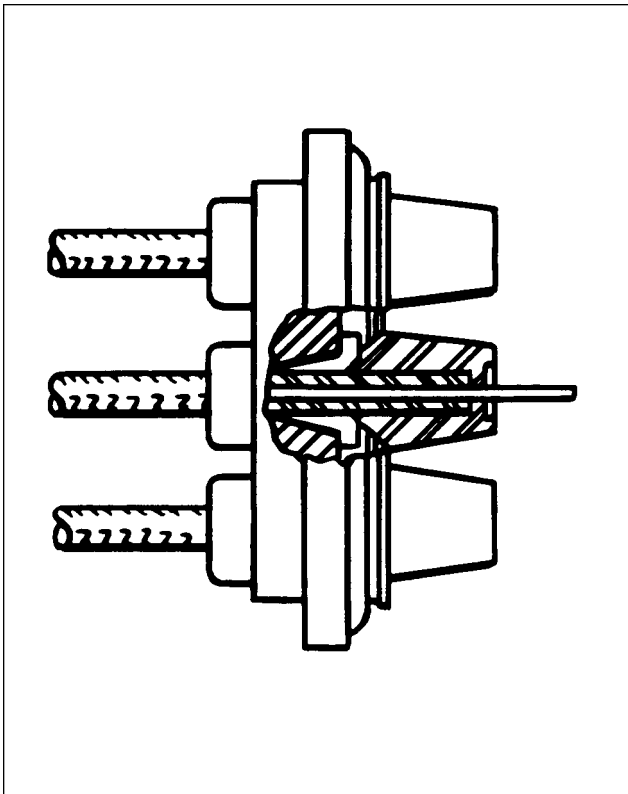

Figure 8A-27. Lead Assembly Installed in Grommet

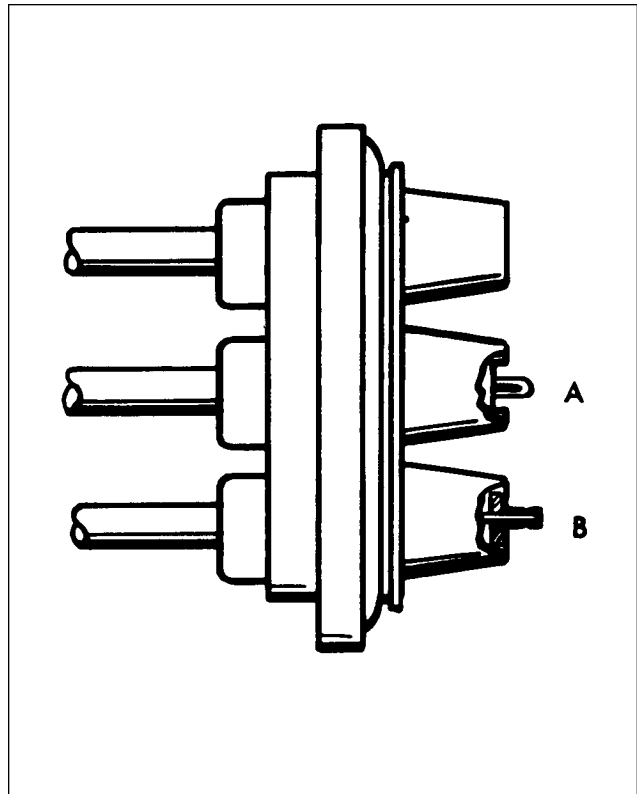

Figure 8A-28. Wire Doubled Over for Installation of Eyelet

CHEROKEE ARROW III SERVICE MANUAL

8A-35. INSTALLATION OF HARNESS. Before installing harness on magneto, check mating surfaces for cleanliness. Spray entire face of grommet with a light coat of Plastic Mold Spray, SM-OOTH Silicone Spray or equivalent. This will prevent harness grommet from sticking to magneto distributor block.

- a. Place the harness terminal plate on the magneto and tighten nuts around the plate alternately to seat cover squarely on magneto. Torque nuts to 18 to 22 inch-pounds.
- b. Route ignition wires to their respective cylinders.
- c. Clamp the harness assembly in position.
- d. Connect the leads to the spark plugs.

8A-36. SPARK PLUGS.

8A-37. REMOVAL OF SPARK PLUGS.

- a. Loosen the coupling nut on the harness lead and remove the terminal insulator from the spark plug barrel well.

NOTE

When withdrawing the ignition cable lead connection from the plug, care must be taken to pull the lead straight out and in line with the center line of the plug barrel; otherwise a side load will be applied, which frequently results in damage to the barrel insulator and connector. If the lead cannot be removed easily in this manner, the resisting contact between the neoprene collar and the barrel insulator will be broken by a rotary twisting of the collar. Avoid undue distortion of the collar and possible side loading of the barrel insulator.

- b. Remove the spark plug from the engine. In the course of engine operation, carbon and other combustion products will be deposited on the end of the spark plug and will penetrate the lower threads to some degree. As a result, greater torque is frequently required for removing a plug than for its installation. Accordingly, the torque limitations given do not apply to plug removal and sufficient torque must be used to unscrew the plug. The higher torque in removal is not as detrimental as in installation, since it cannot stretch the threaded section. It does, however, impose a shearing load on this section and may, if sufficiently severe, produce a failure in this location.

NOTE

Torque indicating handle should not be used for spark plug removal because of the greater torque requirement.

- c. Place spark plugs in a tray that will identify their position in the engine as soon as they are removed.

NOTE

Spark plugs should not be used if they have been dropped.

CHEROKEE ARROW III SERVICE MANUAL

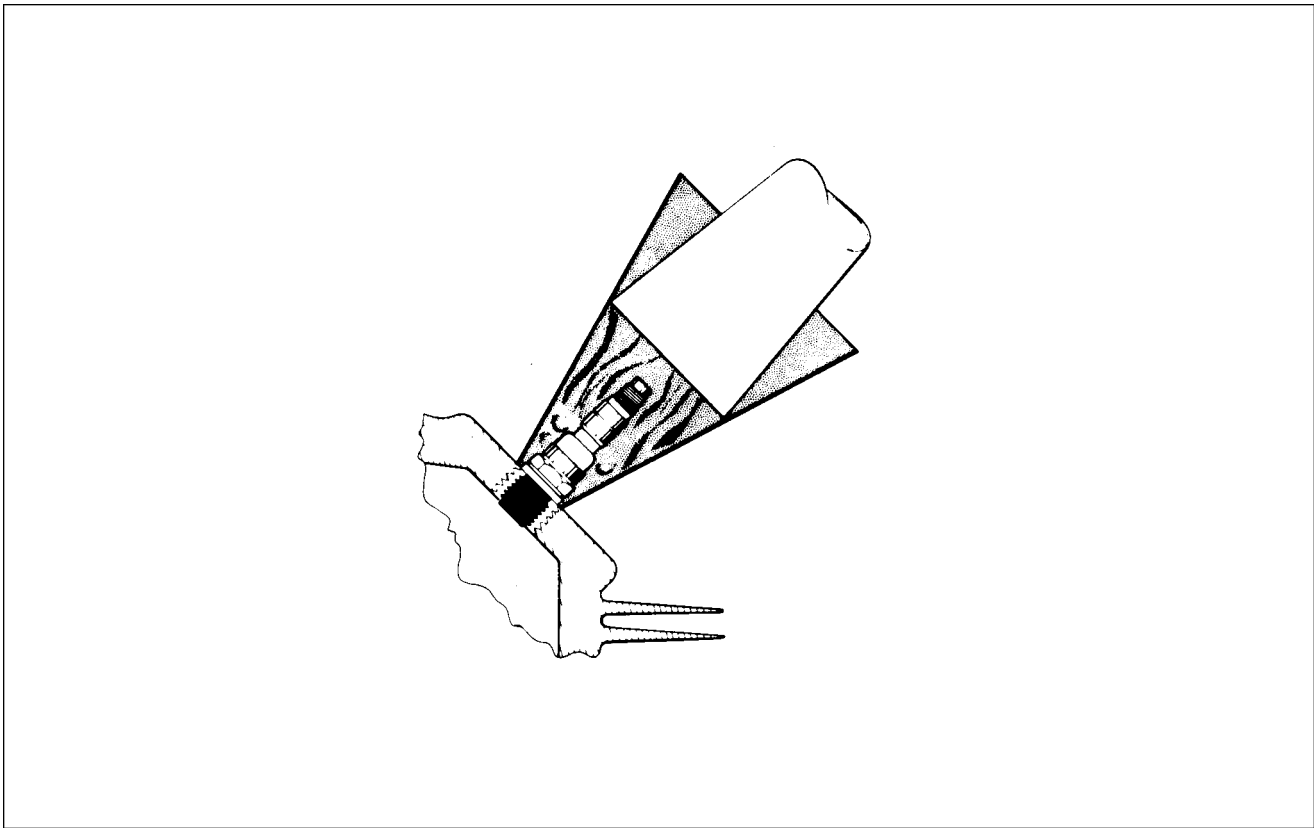

Figure 8A-29. Removing Spark Plug Frozen to Bushing

- d. Removal of seized spark plugs in the cylinder may be accomplished by application of liquid carbon dioxide by a Conical metal funnel adapter with a hole at the apex just large enough to accommodate the funnel of a CO2 bottle. (Refer to Figure 8A-29.) When a seized spark plug cannot be removed by normal means, the funnel adapter is placed over and around the spark plug. Place the funnel of the CO2 bottle inside the funnel adapter and release the carbon dioxide to chill and contract the spark plug. Break the spark plug loose with a wrench. A warm cylinder head at the time the carbon dioxide is applied will aid in the removal of an excessively seized plug.
- e. Do not allow foreign objects to enter the spark plug hole.

8A-38. INSPECTION AND CLEANING OF SPARK PLUG.

- a. Visually inspect each spark plug for the following non-repairable defects:
 - 1. Severely damaged shell or shield threads nicked up, stripped or crossthreaded.
 - 2. Badly battered or rounded shell hexagons.
 - 3. Out-of-round or damaged shielding barrel.
 - 4. Chipped, cracked or broken ceramic insulator portions.
 - 5. Badly eroded electrodes worn to approximately 50% of original size.
- b. Clean the spark plug as required, removing carbon and foreign deposits.
- c. Set the electrode gap at .015 to .018 inches.
- d. Test the spark plug both electrically and for resistance.

CHEROKEE ARROW III SERVICE MANUAL

8A-39. INSTALLATION OF SPARK PLUGS. Before installing spark plugs, ascertain that the threads within the cylinder are clean and not damaged.

- a. Apply anti-seize compound sparingly on the threads and install gasket and spark plugs. Torque 360 to 420 inch-pounds.

CAUTION

Make certain the deep socket is properly seated on the spark plug hexagon as damage to the plug could result if the wrench is cocked to one side when pressure is applied.

- b. Carefully insert the terminal insulator in the spark plug and tighten the coupling unit.

8A-40. LUBRICATION SYSTEM.

8A-41. OIL PRESSURE RELIEF VALVE. The function of the oil pressure relief valve, which is located between the upper right engine mounting lug and No. 3 cylinder, is to maintain engine oil pressure within specified limits by withdrawing a portion of the oil from the circulating system and returning the oil to the sump should the pressure become excessive. This valve is not adjustable; however, particles of metal or other foreign matter lodged between ball and seat will result in a drop in oil pressure. It is advisable, therefore, to disassemble, inspect and clean the relief valve if excessive pressure fluctuations are noted.

The oil pressure relief valve is by no means to be confused with the oil cooler by-pass which is located on the oil pressure screen housing mounting pad. The sole purpose of the by-pass valve is to serve as a safety measure, permitting pressure oil to by-pass the oil cooler entirely in case of an obstruction within the cooler.

8A-42. ENGINE OIL QUICK DRAIN VALVE. When replacing the engine oil quick drain, refer to the Piper Parts Catalog for the correct part number. Installation of an incorrect drain could lead to damage of the sump or the drain itself. This may result in loss of engine oil and a possible engine seizure.

CHEROKEE ARROW III SERVICE MANUAL

TABLE VIIIA-II. ENGINE TROUBLESHOOTING

Trouble	Cause	Remedy
<p>Failure of engine to start.</p>	<p>Lack of fuel.</p>	<p>Check fuel system for leaks. Fill fuel tank.</p> <p>Clean dirty lines, strainers or fuel valves.</p> <p>Check fuel selector valve for proper tank.</p> <p>Check fuel pressure with electric boost pump ON.</p> <p>Check mixture control knob for full rich.</p>
	<p>Overpriming.</p>	<p>Open throttle and “unload” engine by engaging starter. Mixture in idle-cut-off.</p>
	<p>Incorrect throttle setting.</p>	<p>Open throttle to one-eighth of its range.</p>
	<p>Defective spark plugs.</p>	<p>Clean and adjust or replace spark plugs.</p>
	<p>Defective ignition wire.</p>	<p>Check with electric tester and replace defective wires.</p>
	<p>Defective battery.</p>	<p>Replace with charged battery.</p>
	<p>Improper operation of magneto breaker.</p>	<p>Clean points. Check internal timing of magnetos.</p>
	<p>Lack of sufficient fuel flow.</p>	<p>Disconnect fuel line at fuel injector and check fuel flow.</p>

CHEROKEE ARROW III SERVICE MANUAL

TABLE VIIIA-II. ENGINE TROUBLESHOOTING (cont.)

Trouble	Cause	Remedy
Failure of engine to start. (cont.)	Internal failure.	Check oil screens for metal particles. If found, complete overhaul of engine may be indicated.
Failure of engine to idle properly.	<p>Incorrect idle mixture.</p> <p>Leak in the induction system.</p> <p>Incorrect idle adjustment.</p> <p>Uneven cylinder compression.</p> <p>Faulty ignition system.</p> <p>Insufficient fuel pressure.</p>	<p>Adjust mixture.</p> <p>Tighten all connections in the induction system. Replace any parts that are defective.</p> <p>Adjust throttle stop to obtain correct idle.</p> <p>Check condition of piston rings and valve seats.</p> <p>Check entire ignition system.</p> <p>Adjust fuel pressure.</p>
Lower power and uneven running.	<p>Mixture too rich; indicated by sluggish engine operation, red exhaust flame at night. Extreme cases indicated by black smoke from exhaust.</p> <p>Mixture too lean; indicated by overheating or backfiring.</p>	<p>Readjustment of fuel injector by authorized personnel is indicated.</p> <p>Check fuel lines for dirt or other restrictions. Check fuel injection nozzles.</p>

CHEROKEE ARROW III SERVICE MANUAL

TABLE VIIIA-II. ENGINE TROUBLESHOOTING (cont.)

Trouble	Cause	Remedy
<p>Low power and uneven running. (cont.)</p>	<p>Leaks in induction system.</p> <p>Defective spark plugs.</p> <p>Improper fuel.</p> <p>Magneto breaker points not working properly.</p> <p>Defective ignition wire.</p> <p>Defective spark plug terminal connectors.</p>	<p>Tighten all connections. Replace defective parts.</p> <p>Clean and gap or replace spark plugs.</p> <p>Fill tank with fuel of recommended grade.</p> <p>Clean points. Check internal timing of magnetos.</p> <p>Check wire with electric tester. Replace defective wire.</p> <p>Replace connectors on spark plug wire.</p>
<p>Failure of engine to develop full power.</p>	<p>Leak in the induction system.</p> <p>Throttle lever out of adjustment.</p> <p>Improper fuel flow.</p> <p>Restriction in air scoop.</p> <p>Improper fuel.</p>	<p>Tighten all connections and replace defective parts.</p> <p>Adjust throttle lever.</p> <p>Check strainer, gauge and flow at fuel injector inlet.</p> <p>Examine air scoop and remove restrictions.</p> <p>Drain and refill tank with recommended fuel.</p>

CHEROKEE ARROW III SERVICE MANUAL

TABLE VIIIA-II. ENGINE TROUBLESHOOTING (cont.)

Trouble	Cause	Remedy
Figure of engine to develop full power. (cont.)	Faulty ignition.	Tighten all connections. Check system with tester. Check ignition timing.
Rough engine.	Cracked engine mount.	Replace or repair mount.
	Defective mounting bushings.	Install new mounting bushings.
	Uneven compression.	Check compression.
Low oil pressure.	Insufficient oil.	Fill sump with recommended oil.
	Air lock or dirt in relief valve.	Remove and clean oil pressure relief valve.
	Leak in suction line or pressure line.	Check gasket between accessory housing and crankcase.
	Dirty oil strainers.	Remove and clean oil strainers.
	Defective pressure gauge.	Replace gauge.
	Stoppage in oil pump intake passage.	Check line for obstruction. Clean suction strainer.
	High oil temperature.	See "High Oil Temperature" in "Trouble" column.
High oil temperature.	Insufficient air cooling.	Check air inlet and outlet for deformation or obstruction.

CHEROKEE ARROW III SERVICE MANUAL

TABLE VIIIA-II. ENGINE TROUBLESHOOTING (cont.)

Trouble	Cause	Remedy
<p>High oil temperature. (cont.)</p>	<p>Insufficient oil supply.</p> <p>Low grade of oil.</p> <p>Clogged oil lines or strainers.</p> <p>Excessive blow-by.</p> <p>Failing or failed bearing.</p> <p>Defective temperature gauge.</p>	<p>Fill oil sump to proper level with specified oil.</p> <p>Replace with oil conforming to specifications.</p> <p>Remove and clean oil strainers.</p> <p>Usually caused by worn or stuck rings.</p> <p>Examine sump for metal particles. If found, overhaul of engine is indicated.</p> <p>Replace gauge.</p>
<p>Excessive oil consumption.</p>	<p>Low grade of oil.</p> <p>Failing or failed bearings.</p> <p>Worn piston rings.</p> <p>Incorrect installation of piston rings.</p> <p>Failure of rings to seat (new nitrided cylinders.)</p>	<p>Fill tank with oil conforming to specifications.</p> <p>Check sump for metal particles.</p> <p>Install new rings.</p> <p>Install new rings.</p> <p>Use mineral base oil. Climb to cruise altitude at full power and operate at 75% cruise power setting with high oil temperature until oil consumption stabilizes.</p>

SECTION IX

FUEL SYSTEM

Paragraph	Aerofiche Grid No.
9-1. Introduction	2E9
9-2. Description	2E9
9-3. Troubleshooting.....	2E14
9-4. Fuel Tanks.....	2E14
9-5. Removal of Fuel Tanks.....	2E14
9-6. Inspection and Repair of Fuel Tank.....	2E14
9-7. Installation of Fuel Tank.....	2E14
9-8. Fuel Quantity Transmitter Unit	2E17
9-9. Removal of Fuel Quantity Transmitter Unit.....	2E17
9-10. Installation of Fuel Quantity Transmitter Unit.....	2E17
9-11. Fuel Quantity Transmitter/Gauge Check (Installed).....	2E18
9-11a. Fuel Quantity Indicator.....	2E18
9-12. Fuel Selector Valve.....	2E19
9-13. Removal of Fuel Selector Valve.....	2E19
9-14. Installation of Fuel Selector Valve	2E19
9-15. Fuel Filter Bowl and Screen.....	2E19
9-16. Removal of Fuel Filter Bowl and Housing.....	2E19
9-17. Installation of Fuel Filter Bowl and Screen.....	2E20
9-18. Cleaning and Inspection of Filter Bowl Screen.....	2E20
9-19. Electric Fuel Pump (Airborne) (PA-28R-201T).....	2E20
9-20. Removal and Installation of Electric Fuel Pump.....	2E20
9-20a. Auxiliary Fuel Pump Adjustment (Installed).....	2E20
9-20b. Auxiliary Fuel Pump System Operational Check	2E22
9-21. Electric Fuel Pump (Weldon) (PA-28R-201).....	2E23
9-22. Removal of Fuel Pump.....	2E23
9-23. Disassembly, Repair and Assembly of Fuel Pump.....	2E23
9-24. Adjustment of Electric Fuel Pump (Bench Test).....	2E24
9-25. Adjustment of Electric Fuel Pump (In Airplane)	2E24
9-26. Installation of Fuel Pump	2E24
9-27. Cleaning Fuel System.....	2E24
9-28. Inspection and Tightening of Fuel Line Union Fittings	2F1
9-29. Replacement of Fittings.....	2F2

CHEROKEE ARROW III SERVICE MANUAL

SECTION IX

FUEL SYSTEM

9-1. INTRODUCTION. The fuel system components covered in this section consist of the fuel tanks, selector valves, filter screens, fuel pumps and quantity transmitter units. Instructions are given for remedying difficulties which may arise in the normal operation of the fuel system. The instructions are organized so the mechanic can refer to: Removal, Repair, Installation and Adjustment of each part of the system.

Maintenance for fuel injection may be found under Power Plant, Section VIII or VIIIA.

9-2. DESCRIPTION.

PA-28R-201 (Refer to Figure 9-1.)

The fuel system was designed with simplicity in mind. It incorporates two fuel tanks, one in each wing containing 38.5 U.S. gallons, giving a total capacity of 77 gallons, of which 72 gallons are usable. The tanks are attached to the leading edge of the wing with screws and are an integral part of the wing structure. This allows for removal for service. An auxiliary electric fuel pump is provided in case of a failure of the engine driven pump. A rocker type switch for controlling the electric pump is located on the switch panel above the throttle quadrant. The electric pump should be on for take-off, switching tanks and during landing.

The fuel tank selector, which allows the pilot to control the flow of fuel to the engine, is located on the left side wall below the instrument panel. It has three positions: OFF, LEFT TANK and RIGHT TANK. The arrow on the handle of the selector points to the tank which is supplying fuel to the engine. The valve also incorporates a safety latch which prevents inadvertently selecting the "OFF" position.

Each tank has an individual quick drain located at the bottom inboard rear corner. The fuel strainer also incorporates a quick drain which is located in the left front corner of the firewall. The quick drain protrudes from the cowling to allow easy draining of the fuel strainer. All three drains should be drained before every flight and checked for contamination.

The fuel tanks are vented individually by a vent tube which protrudes below the bottom of the wing at the rear outboard corner of each fuel tank. The vent should be checked periodically to ascertain that the vent is not obstructed and allows free passage of air.

Fuel quantity and pressure are indicated on gauges located in the instrument cluster to the left of the switch panel.

PA-28R-201T (Refer to Figure 9-2.)

The fuel system was designed with simplicity in mind. It incorporates two fuel tanks, one in each wing containing 38.5 U.S. Gallons, giving a total capacity of 77 gallons, of which 72 gallons are usable. The minimum fuel grade is 100/130 octane (green) or 100LL (blue). The tanks are attached to the leading edge of the wing with screws and are an integral part of the wing structure. This allows for removal for service. The tanks are vented individually by a vent tube which protrudes below the bottom of the wing at the rear inboard corner of each tank. The vents should be checked periodically to ascertain that the vent is not obstructed and will allow free passage of air.

Each fuel tank has as individual quick drain located at the bottom inboard rear corner. The fuel strainer also incorporates a quick drain, which is located on the left lower portion of the firewall. The quick drain protrudes thru the cowling to allow easy draining of the fuel strainer.

CHEROKEE ARROW III SERVICE MANUAL

A fuel tank selector allows the pilot to control the flow of fuel to the engine, and is located on the left side wall below the instrument panel. It has three positions: OFF, LEFT TANK and RIGHT TANK. The arrow on the handle of the selector points to the tank which is supplying fuel to the engine. The vapor return from the engine is also routed back to the tank selected. When the selector valve is in the OFF position, vapor return is routed back to the right fuel tank. The valve also incorporates a safety latch which prevents inadvertently selecting the "OFF" position.

The engine fuel injection system is a "continuous flow" type, which utilizes a vapor return line leading back to the fuel tanks. This line provides a route back to the tanks for vapor laden fuel that has been separated in the injector pump swirl chamber. The engine has an engine driven fuel pump that is a part of the fuel injection system. As auxiliary fuel system is provided. The purpose of the electrically powered auxiliary fuel system is to supply fuel to the engine in case of engine driven fuel pump shaft failure or malfunction, for ground and inflight engine starting, and for vapor suppression. The auxiliary fuel pump switch is located on the instrument panel above the engine control quadrant, and is a three position rocker switch; LO, HI and OFF. The LO auxiliary fuel pressure is selected by pushing the top of the switch. The HI auxiliary fuel pressure is selected by pushing the bottom of the switch, but this can be done only after unlatching the adjacent guard. When the HI auxiliary fuel pump is activated, an amber light near the annunciation panel is illuminated. This light dims whenever the pump pressure reduces automatically and manifold pressure is below approximately 21 inches.

In case of a failed engine-driven fuel pump, the auxiliary electric fuel pump should be set on HI. Adequate pressure and fuel flow will be supplied for up to approximately 75% power. Manual leaning to the correct fuel flow will be required at altitudes above 15,000 feet and for engine speeds less than 2300 RPM. An absolute pressure switch automatically selects a lower fuel pressure when the throttle is reduced below 21" Hg manifold pressure and the HI auxiliary fuel pump is on.

NOTE

Excessive fuel pressure and very rich fuel/air mixtures will occur if the HI position is energized when the engine fuel injection system is functioning normally.

Low auxiliary fuel pressure is available and may be used during normal engine operation both on the ground and inflight for vapor suppression should it be necessary as evidenced by unstable engine operation or fluctuating fuel flow indications during idle or at high altitudes.

A spring loaded OFF primer button switch, located on the instrument panel and is used to select HI auxiliary fuel pump operation for priming, irrespective of other switch positions. The primer button may be used for both hot or cold engine starts.

On airplanes equipped with an optional engine primer system (identified by Placard below primer button shown in Figure 9-4), the primer switch location and actuation is the same as the basic airplane. However, this system does provide a separate primer system as an integral part of the engine fuel system. An electrically operated diverter valve is located in the metered fuel supply line between the air throttle valve and the manifold valve. Other components are two primer nozzles, located in the intake manifold on each side of the engine, the interconnecting fuel lines, and fine wire spark plugs. Actuation of the engine primer switch operates the auxiliary electric fuel pump on HI and energizes the diverter valve which supplies fuel to each primer nozzle. The diverter valve does not shut off all fuel flow to the manifold valve, therefore some quantity of fuel is also supplied to each cylinder nozzle during priming. Operation of the auxiliary fuel pump on HI and LO is unchanged.

CHEROKEE ARROW III SERVICE MANUAL

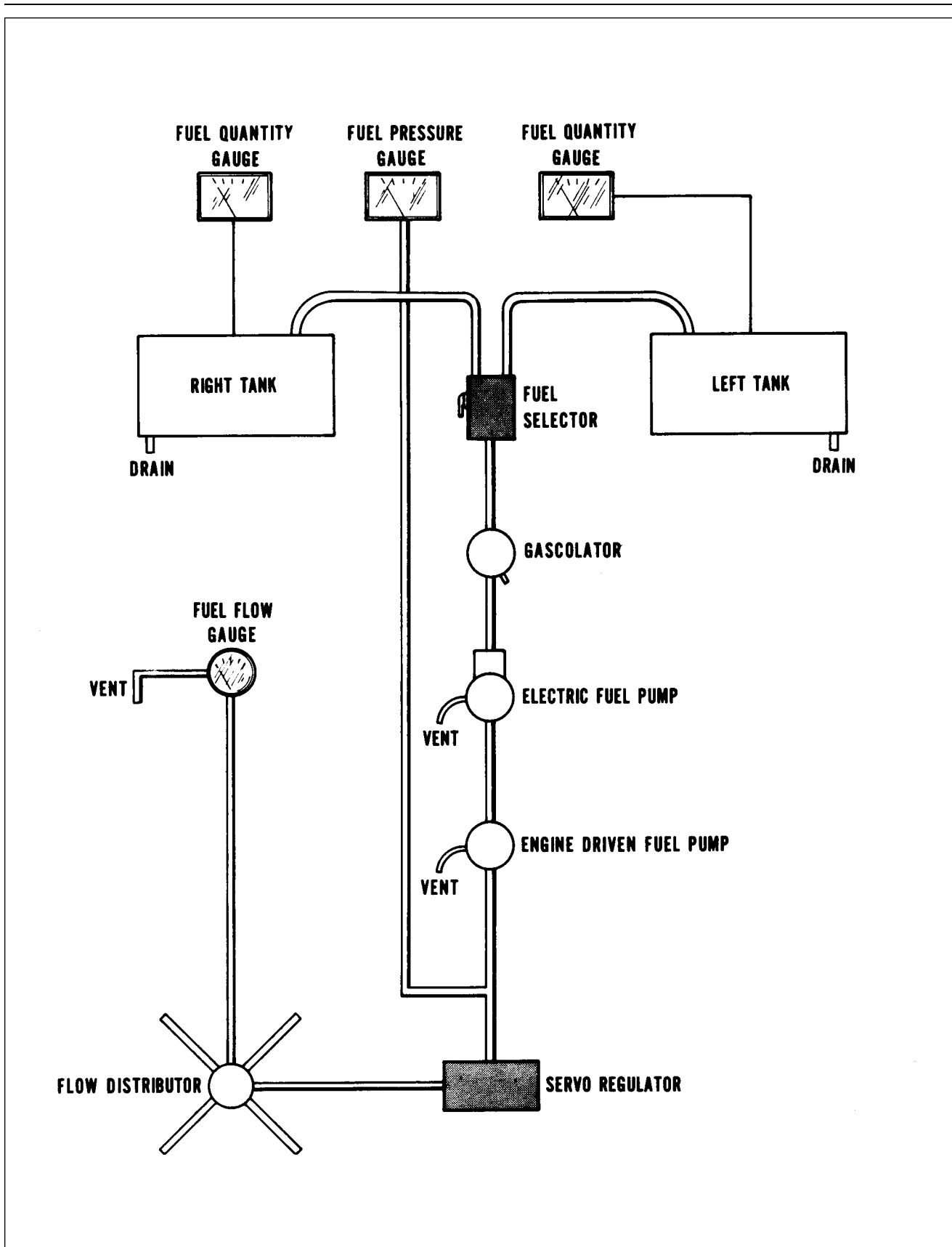

Figure 9-1. Fuel System Diagram (PA-28R-201)

CHEROKEE ARROW III SERVICE MANUAL

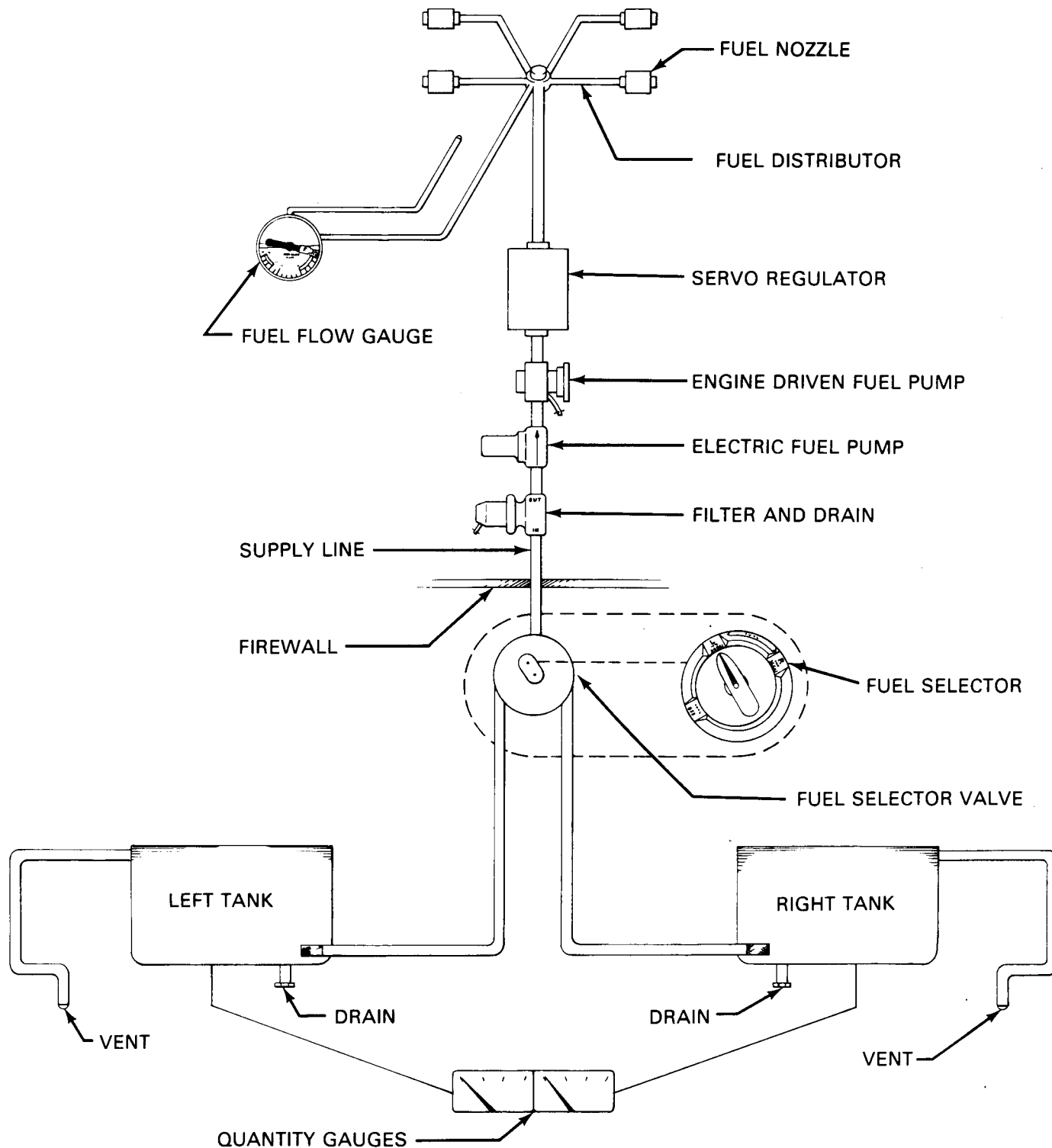

Figure 9-1a. Fuel System Diagram (PA-28R-201) S/N 2837001 and up

CHEROKEE ARROW III SERVICE MANUAL

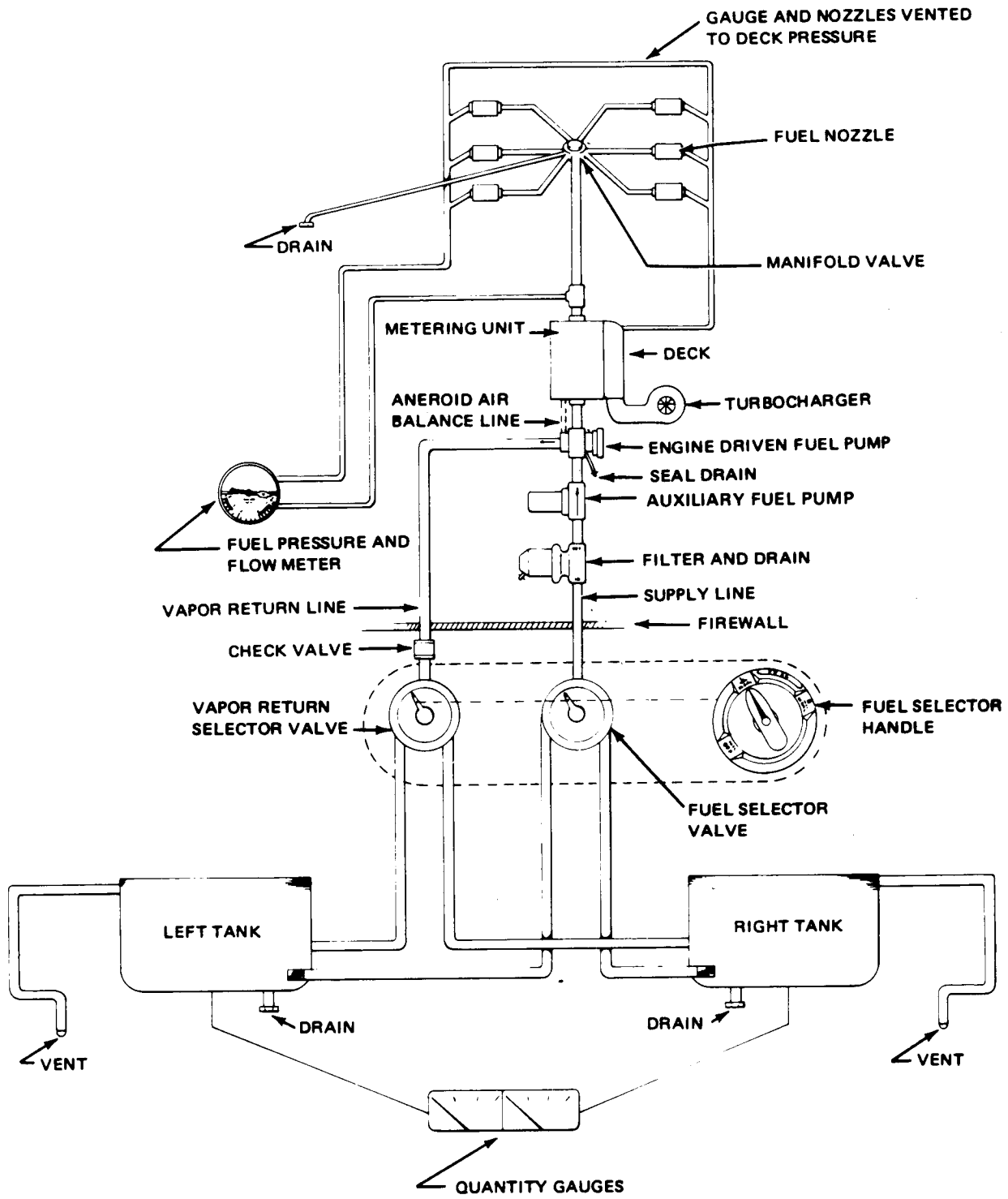

Figure 9-2. Fuel System Diagram (PA-28R-201T)

CHEROKEE ARROW III SERVICE MANUAL

9-3. TROUBLESHOOTING. Troubles peculiar to the fuel system are listed in Table IX-III along with their probable causes and suggested remedies. When troubleshooting, check from the power supply to the items affected. If no trouble is found by this method, the trouble probably exists inside individual pieces of equipment; they may be removed from the airplane and an identical unit or units, tested and known to be good, installed in their place.

9-4. FUEL TANKS.

9-5. REMOVAL OF FUEL TANKS.

- a. Drain the fuel from the fuel tank. (Refer to Draining Fuel System, Section II.)
- b. Remove the screws from around the perimeter of the tank assembly.
- c. Disconnect fuel line attached to tank. On PA-28R-201, disconnect vapor return line.
- d. Pull the tank away from the wing assembly far enough to gain access for removal of the sender wires.
- e. The tank is now free to be removed.

9-6. INSPECTION AND REPAIR OF FUEL TANK. If the fuel tank was previously sloshed, the entire interior of the tank should be inspected for peeling of small areas of the sloshing compound. Indications are that in the majority of cases, the peeling is started just inside the filler neck as a result of the metal nozzle of the gas filler hose nicking the compound. The following items are recommended:

- a. The entire interior of the main tanks should be inspected with the tanks drained. This is accomplished with a mirror and inspection light through the filler neck. Small scrapes in the film adjacent to the filler neck may be disregarded provided there is no indication of peeling.
- b. If peeling has occurred and separated material is found, the fuel tank should be removed and resloshed in accordance with the instructions included with each can of Randolph Sloshing Sealer, 802, Piper part number 757 572V. (Approved under Mil. Spec. MIL-L-G0478.) One gallon of sloshing compound is required per tank. After sloshing the tank, apply 1.5 lbs. air pressure and using a soap and water solution, check for leaks.
- c. After resloshing, reinspect as above at intervals of 100 hours. These inspections may be discontinued after the second inspection if no peeling is discovered.

NOTE

The fuel tank should be replaced if the tank is damaged to the extent it cannot be repaired by the above method.

9-7. INSTALLATION OF FUEL TANK

- a. Slide the tank partly into position and connect the sender wires. On PA-28R-201T, connect vapor return line.
- b. Slide the tank completely into place and secure with screws around its perimeter.
- c. Connect the fuel line.
- d. Fill the fuel tank and check for leaks, unrestricted fuel flow and proper sender indications on the quantity gauge (refer to paragraph 9-11).

WARNING

Inspect aircraft for compliance with Piper Service Bulletin No. 625A, Fuel and Vapor Return Lines Support. Failure to comply may lead to failure of either line resulting in fuel leakage and possible engine failure.

CHEROKEE ARROW III SERVICE MANUAL

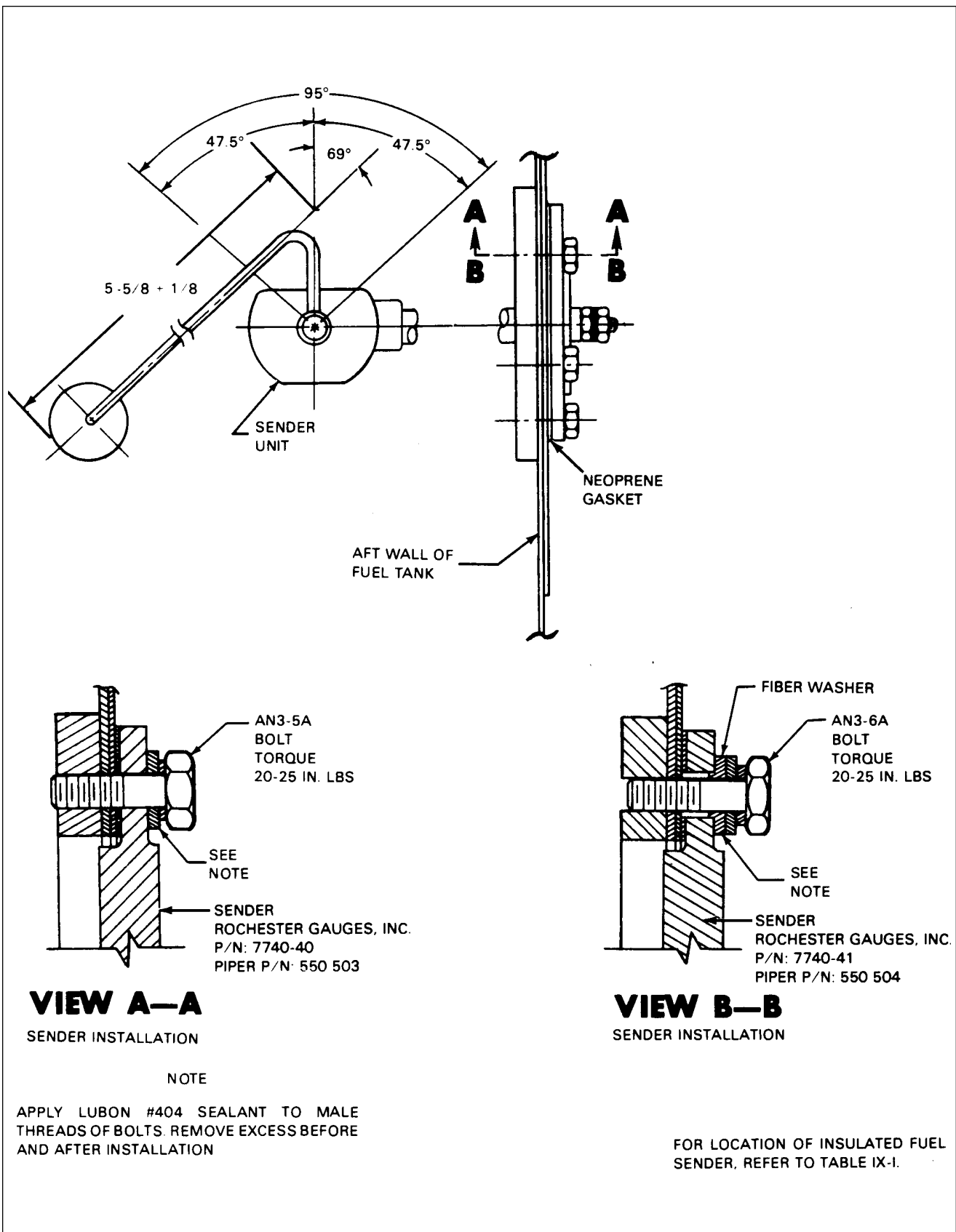

Figure 9-3. Fuel Sender Units Installation

CHEROKEE ARROW III SERVICE MANUAL

TABLE IX-I. FUEL SENDER LOCATIONS

	Piper P/N: 550 504 Rochester P/N: 774041 See Note	Piper P/N: 550 503 Rochester P/N: 7740-40
PA-28R-201 S/N: 28R-7737002 to 28R-7737161 inclusive PA-28R-201T S/N: 28R-7703001 to 28R-7703380 inclusive	Inboard	Outboard
PA-28R-201 S/N: 28R-7737162 and up PA-28R-201T S/N: 28R-7703381 and up	Outboard	Inboard
Note: Fuel quantity sender Piper P/N: 550 504 requires fiber washer insulators. Refer to Figure 9-3, View B-B.		

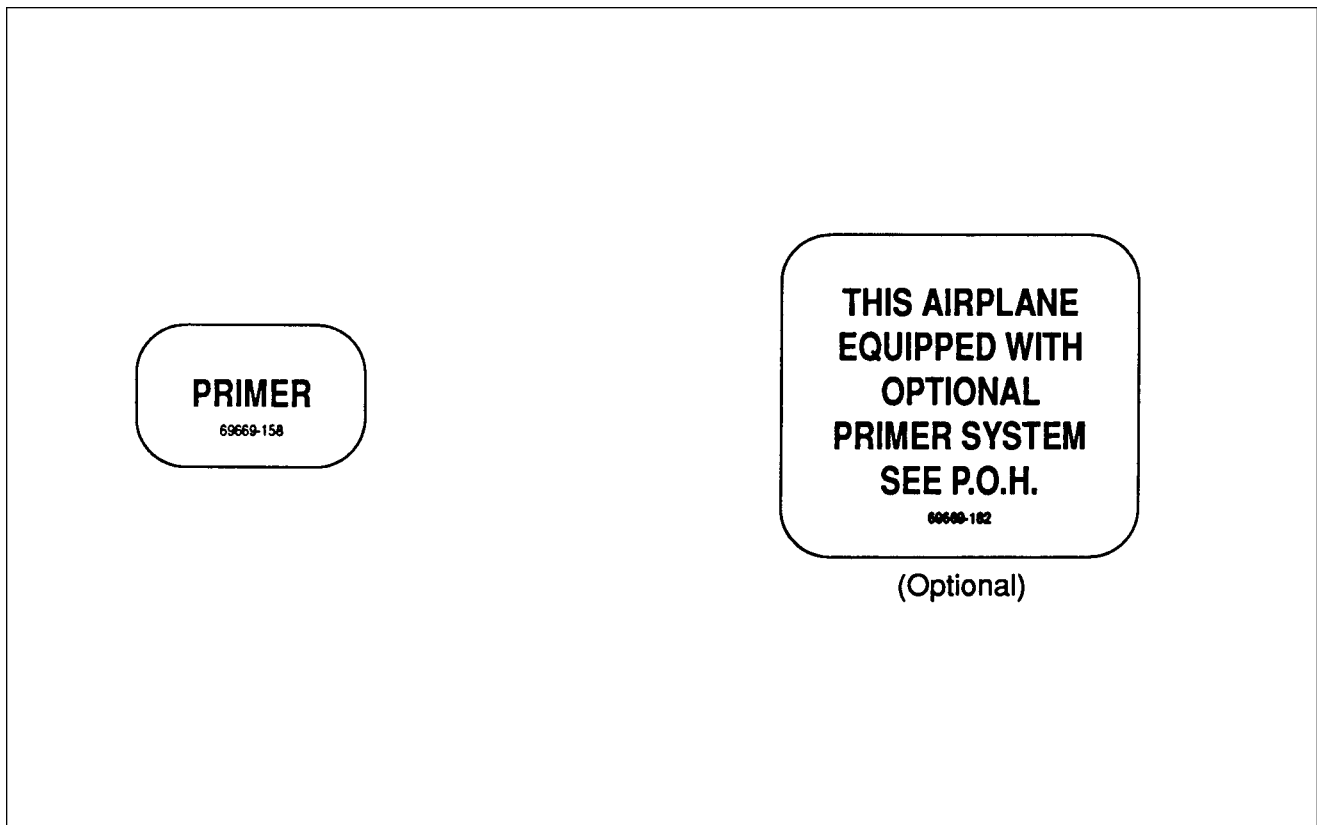

Figure 9-4. Engine Primer System Placard (PA-28R-201T)

9-8. FUEL QUANTITY TRANSMITTERS

9-9. REMOVAL OF TRANSMITTERS. (Refer to Figure 9-3.)

- a. Ascertain that the fuel tank of the particular unit is empty.
- b. Remove the access panel on the lower surface of the wing below the sender unit being serviced at Wing Station 92-75.
- c. Reaching through the access opening, disconnect the electrical lead(s) from the sender unit(s).

NOTE

The inboard and outboard senders are different units in that one unit (Piper P/N 550 504) requires fiber insulating washers. When removing the bolts and washers from this unit, be careful not to damage the fiber insulating washers and make sure when reinstalling the sender, to use the correct bolts and washers. The fiber washers insulate the unit from the tank assembly. Refer to Table IX-I for proper fuel sender location.

- d. Reaching through the access opening, remove the five bolts and washers securing the sender unit to the rear surface of the tank.

9-10. INSTALLATION OF TRANSMITTERS. (Refer to Figure 9-3.)

- a. Position the sender unit with its gasket on the aft surface of the fuel tank and align the mounting holes of the unit and mounting plate.

NOTE

If both sender units were removed from the same fuel tank, ensure the correct repositioning upon reinstallation.

- b. Apply Lubon No. 404 sealant to the male threads of the five bolts and secure the sender unit to the tank. Remove any excess sealant from the bolts before and after installation.

NOTE

Ascertain that the correct arrangement of washers and insulators are used upon installation of sender units. Torque bolts 20-25 inchpounds.

- c. By reaching through the access opening on the lower surface of the wing, connect the electrical leads to the units.

CHEROKEE ARROW III SERVICE MANUAL

- d. Fill the fuel tank with fuel. During filling check for proper fuel quantity gauge readings. Check for any leaks around the sender unit attachment surface by looking through the access opening on the lower surface of the wing.
- e. Upon completion of the leak check, install the lower access panel and secure with required attachment screws.

9-11. FUEL QUANTITY TRANSMITTER/GAUGE CHECK. Fuel quantity transmitter units and gauges may be checked, while installed in the airplane, by the following procedure:

NOTE

To externally check the float assembly, see Figure 9-3 and Table IX-II. When using the following procedure, the electrical system should apply 14-volts to the gauge.

- a. Turn the fuel selector valve off.
- b. Completely drain the fuel tank that relates to the gauge to be checked.
- c. Level the airplane longitudinally and laterally.
- d. Turn the master switch on and observe the fuel quantity gauge. It should read empty. Refer to Table IX-II for tolerances that are permitted between the fuel gauge reading and the actual fuel in the tank.
- e. Add fuel to the tank in the amount of five U.S. gallon increments until the tank is full and observe gauge readings.

NOTE

It is permissible to adjust the float assembly to obtain specified tolerances. This adjustment should be accomplished per instructions titled Check and Adjustment of Fuel Quantity Transmitters.

9-11a. FUEL QUANTITY INDICATOR.

The two fuel quantity gauges are mounted in the console on the instrument panel. These instruments are calibrated in fractional divisions of one fourth, one half, three fourths and full. Two transmitter units are installed in each fuel cell. These units contain a resistance strip and a movable control arm. The position of this arm is controlled by a float in the fuel cell and this position is transmitted electrically to the indicator gauge to show the amount of the fuel in the cell.

TABLE IX-II. FUEL QUANTITY TRANSMITTER CALIBRATION TOLERANCES

UNIT IDENTIFICATION (See Note)	FLOAT POSITION	RESISTANCE
550 503 Piper 550 504	Empty	0 to 1.0 ohm max
7740-40 Rochester 7740-41	0.9 in. above Empty	6.5 ± 0.5 ohms
	Full	45 ± 2 ohms
NOTE: Refer to Table IX-I for appropriate fuel sender location.		

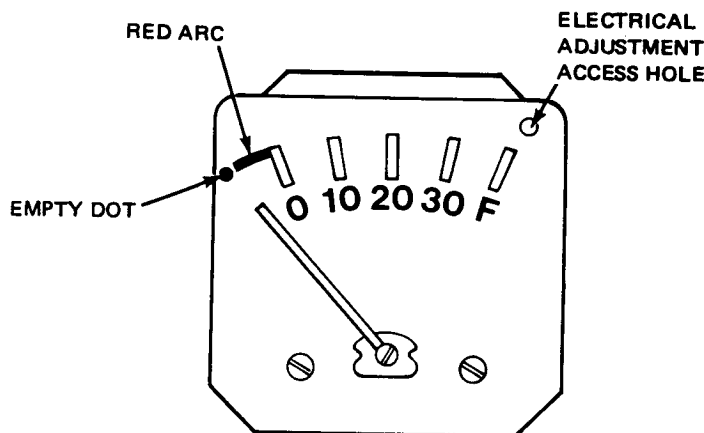

Figure 9-5. Fuel Quantity Indicator

9-12. FUEL SELECTOR VALVE.

9-13. REMOVAL OF FUEL SELECTOR VALVE.

- a. Remove three screws holding selector cover and the screw holding the handle. It will be necessary to remove side panel to gain access to the selector valve.
- b. Remove selector handle and cover.
- c. Disconnect fuel lines from the selector valve.
- d. Remove fuel valve assembly by removing attaching screws.

9-14. INSTALLATION OF FUEL SELECTOR VALVE.

- a. Secure the valve to the bulkhead attachment location with attaching screws.
- b. Connect the fuel lines to the valve.
- c. Install side panel.
- d. Install the selector cover with attaching screws.
- e. Install the valve control handle with attaching screws.

9-15. FUEL FILTER BOWL AND SCREEN. (Refer to Figure 9-6.)

9-16. REMOVAL OF FUEL FILTER BOWL AND HOUSING.

- a. Ascertain that the fuel shutoff is in the off position.
- b. Remove the engine cowlings by releasing the cowl fasteners or the attaching screws, depending on the type installed. Be certain that all electrical leads are disconnected prior to removal of the cowl.
- c. Disconnect the fuel lines from the filter bowl housing.
- d. Cut the safety wire, loosen the bail nut, move the bail wire to the side and remove the bowl.
- e. Remove the housing of the filter bowl by spreading the ends of the bail wire allowing the housing to be lifted from the bracket.

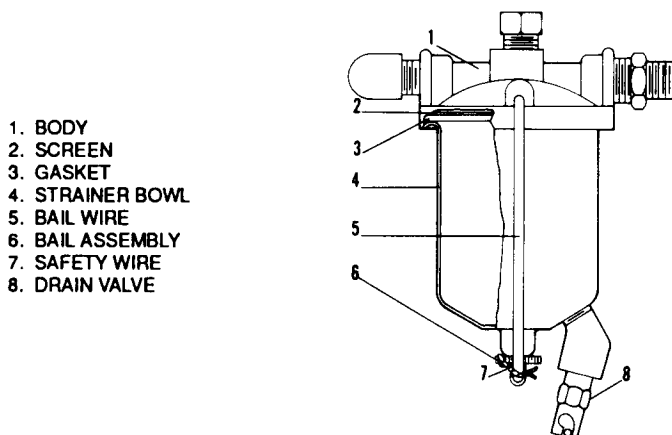

Figure 9-6. Fuel Filter Bowl and Screen

9-17. INSTALLATION OF FUEL FILTER BOWL AND SCREEN.

- a. Position the top of the filter bowl to the bracket and connect the fuel lines.
- b. Spread the bail wire ends and insert them through the holes in the side of the mounting bracket and the top of the filter bowl.
- c. Position the bowl and bail wire and tighten the bail nut.
- d. Safety the bail nut and the bail wire assembly.
- e. Install the engine cowling.

9-18. CLEANING AND INSPECTION OF FILTER BOWL SCREEN.

- a. Follow steps a, b and d of paragraph 9-16 for removal of the filter bowl.
- b. Remove the gasket and screen from the filter housing.
- c. Clean the screen and bowl with acetone or a suitable dry type solvent. If damaged, replace screen.
- d. Replace the screen followed by a new gasket.
- e. Position the bowl and bail wire and tighten the bail nut.
- f. Safety the bail nut and the bail wire assembly.

9-19. ELECTRIC FUEL PUMP. (AIRBORNE) (PA-28R-201T)

9-20. REMOVAL AND INSTALLATION OF ELECTRIC FUEL PUMP. The electric rotary vane type fuel pump is mounted in a bracket on the forward side of the firewall. To remove pump, proceed as follows:

- a. Remove engine cowl to gain access to the pump.
- b. Remove fuel lines from the pump and disconnect the electrical leads.
- c. Remove straps holding pump in position.
- d. Do not attempt to disassemble or repair the fuel pump. If fuel pump proves to defective, it should be replaced.
- e. Reinstall pump in reverse order of removal.

9-20a. AUXILIARY FUEL PUMP SYSTEM ADJUSTMENT. (INSTALLED)

- a. Install a calibrated pressure gauge in the fuel line between the electric fuel pump and engine.
- b. Remove the aft access panel in the baggage compartment. The slider resistor is located at station 165.5 attached to the plate containing the voltage and overvoltage relays.

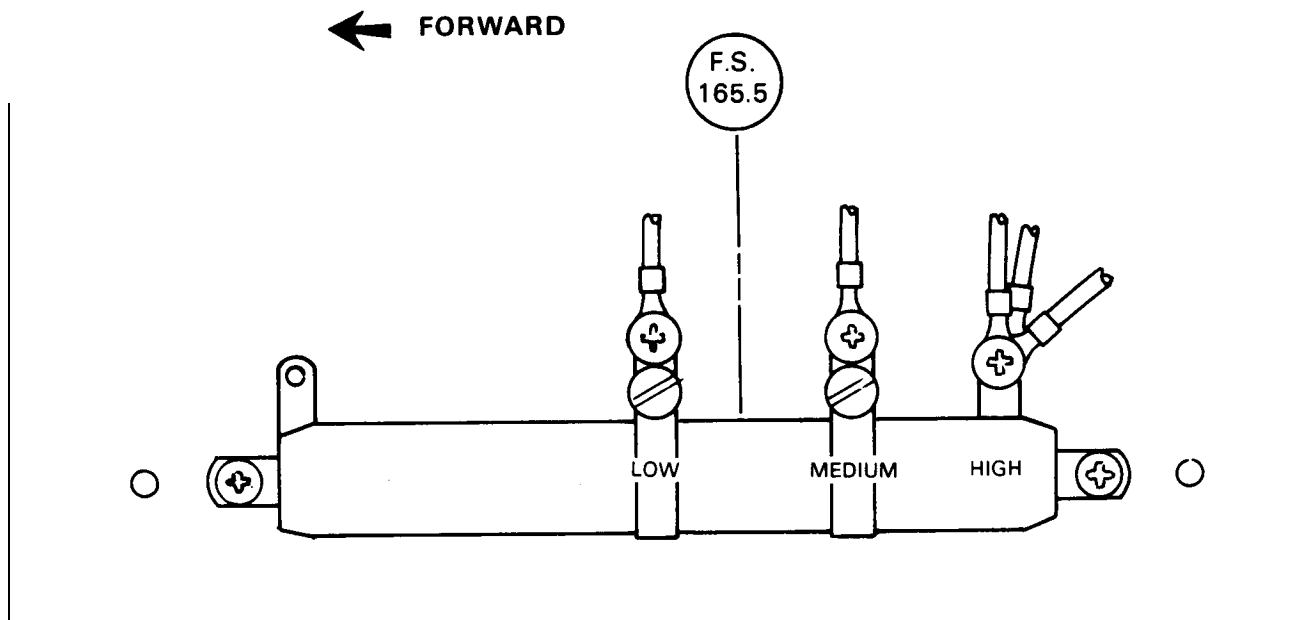

Figure 9-7. Aux Fuel Pump Variable Resistor

- c. Disconnect the wire from the auxiliary pump circuit breaker.
- d. From an external power source containing a voltmeter, connect the negative lead to ground and the positive lead to the slide resistor high terminal.
- e. Connect a calibrated voltmeter across the auxiliary fuel pump and adjust the external power source until 12.0 to 12.5 volts direct current is indicated. Record the voltage reading from the external power source.
- f. Check the calibrated pressure gauge. At least 31 to 37 psi should be indicated.
- g. Connect the positive lead to the LOW power terminal of the slide resistor.
- h. Adjust the power supply voltage level to obtain that recorded in step e.
- i. Slide the LOW terminal on the resistor to obtain a pump pressure of 8 to 10 psi.
- j. Readjust power supply and LOW terminal to ensure a pump pressure of 8 to 10 psi at a power supply voltage of the previously recorded in step e.
- k. Secure the LOW terminal slider.
- l. Connect the positive lead to the MEDIUM power terminal of the slide resistor and adjust the power supply voltage level to that recorded in step e.
- m. Position the MEDIUM terminal on the resistor to obtain a pump pressure of 23.5 to 24.5 psi and readjust the power supply and terminal to ensure that pressure at a power supply voltage recorded in step e.
- n. Secure the MEDIUM power terminal and attach disconnected wires.
- o. If the aircraft is equipped with a fuel diverter valve, operate the primer switch and ensure the valve is being energized. Release the primer switch and operate the fuel pump switch in the HI-BOOST position and ensure that the pump operates and that the diverter valve does not.

CHEROKEE ARROW III SERVICE MANUAL

9-20b. AUXILIARY FUEL PUMP SYSTEM OPERATIONAL CHECK.

- a. Install a calibrated fuel pressure gauge in the fuel line between the electric fuel pump and the engine and disconnect the electrical leads to the manifold pressure switch located on the firewall.
- b. Turn all cockpit controllable switches off. **WARNING** Due to possible fuel overflow, conduct this operation in a no-smoking, well ventilated area.
- c. With the master switch in the on position, place the electric fuel pump switch in the LOW position. The calibrated fuel pressure gauge should indicate a pressure increase, indicating pump operation. The pressure should not exceed 10 psi.
- d. Set electric fuel pump switch in the HIGH position. Record the pressure indicated on the calibrated pressure gauge. The pressure on the gauge should be higher than that recorded in step c but not more than 24.5 psi.
- e. Switch off Master Switch and reconnect leads to the Manifold Pressure Switch.
- f. Ascertain that the fuel pump switch is still in the HIGH position and return the master switch to the on position. Record the pressure registered on the calibrated pressure gauge. The pressure attained in this step should be higher than that recorded in step d, but not in excess of 37 psi.
- g. Place the fuel pump switch in the off position and depress the prime switch. Record the pressure indicated and check against that recorded in step d. The pressure attained in this step should be higher than that recorded in step d, but not in excess of 37 psi.

THIS SPACE INTENTIONALLY LEFT BLANK

CHEROKEE ARROW III SERVICE MANUAL

TABLE IX-III. TRANSMITTER/FUEL GAUGE TOLERANCES

Actual Fuel in Tank (U. S. Gal)	Tolerance Gauge Reading (U.S. Gal)	(Plus or Minus) (Needle-Widths)
Full	F	2
32.5	30	2
22.5	20	2
12.5	10	1
2.5	Zero	Plus 0 - Minus 1
0 Empty	Empty Dot	1/2

9-21. ELECTRIC FUEL PUMP. (WELDON) (PA-28R-201)

9-22. REMOVAL OF FUEL PUMP.

- a. Remove the cowling by releasing the cowl fasteners and removing the screws around the nose gear and across the aft edge of the cowl.
- b. Ascertain the fuel shutoff is in the off position.
- c. Disconnect the electrical leads from the pump.
- d. Disconnect the fuel lines from the pump.
- e. Remove the cap screws, washers and plate and remove the pump from the airplane.

9-23. DISASSEMBLY, REPAIR AND ASSEMBLY OF FUEL PUMP. Overhaul of the fuel pump is not recommended because of special tools needed. If overhaul is necessary, the pump should be returned to:

The Weldon Tool Company
3000 Woodhill Road
Cleveland, Ohio 44104

However, some repairs may be accomplished as follows:

- a. Replacement of shaft seal.
 1. Separate the pump end assembly from the motor by removing the four machine screws. Note the relationship of the pump and motor before separation.
 2. The shaft seal is assembled with a light press fit into the insert. It can be pried loose from the insert without disassembly of the pump.
 3. Check the shaft for burrs, scratches or any defects which might cause the seal to wear. Any defect would be cause for pump replacement.
 4. Position a new seal on the shaft and press into place.
 5. Assemble the pump end assembly to the motor in the original position. Install the four machine screws and safety.
- b. Repair of the relief valve.
 1. Remove the adjusting screw from the pump end assembly. Do not change the position of the jam nut.
 2. Remove the valve plunger and spring.
 3. Inspect the valve seat, plunger and spring for condition and wear. If the valve seat is damaged, the pump should be replaced.
 4. Reassemble the plunger, spring, if installed, and adjusting screw to the pump.
 5. Adjust the pump pressure as described in paragraph 9-24 or 9-25.

CHEROKEE ARROW III SERVICE MANUAL

9-24. ADJUSTMENT OF ELECTRIC FUEL PUMP (BENCH TEST).

- a. Ascertain that the pump is sufficiently lubricated to prevent damage if run dry for a period greater than five minutes.
- b. Connect the electric leads to a 14-volt dc power source.
- c. Using a suitable container with a proper octane fuel, connect a fuel line from a container to the inlet side of the pump.
- d. Connect another line from the outlet side of the pump to a pressure gauge and bypass valve and back to the container.
- e. Run the pump with the bypass valve open until a steady flow of fuel is obtained. Then close the bypass valve and check the pressure gauge for a proper reading of 26 to 29 psi, no flow. Do not keep the bypass valve closed for more than one minute during pump operation and adjustment.
- f. Loosen the locknut and turn the adjusting screw until there is a reading of 29 psi maximum, no flow, on the gauge. Repeat steps e and f until the proper pressure is obtained.
- g. Disconnect the power source from the pump and lock the adjustment screw with the locknut. Remove the fuel lines from the pump.

9-25. ADJUSTMENT OF ELECTRIC FUEL PUMP (IN AIRPLANE).

- a. With the access panel removed and the fuel selector in the OFF position, remove the fuel line from the outlet end of the pump.
- b. Connect a test line with a bypass valve and pressure gauge to the outlet end of the pump.
- c. Place a container below the pump to catch any fuel from the test line during the adjustment of the pump.
- d. Turn the fuel selector on, open the bypass valve on the test line and start the pump.
- e. When a steady flow of fuel is obtained, close the bypass valve and check the reading on the pressure gauge. It should read 26 to 29 psi, no flow. Do not keep bypass valve closed for more than one minute during pump operation and adjustment.
- f. Loosen locknut on adjusting screw and turn screw to obtain the proper pressure of 29 psi maximum, no flow. Repeat step g and h until adjustment is complete. Lock adjusting screw with locknut.
- g. Turn off fuel pump and close fuel selector. Remove the test line from the pump.
- h. Reconnect the original fuel line to the pump. Open fuel selector and run the pump to check for any fuel leaks.
- i. Shut off the pump, close the fuel selector and replace and secure the access panel.

9-26. INSTALLATION OF FUEL PUMP.

- a. Position the fuel pump inside the cover assembly and secure with cap screws, washers and plate.
- b. Connect the fuel lines to the fuel pump.
- c. Connect the electrical leads to the pump.
- d. Turn the fuel selector on and operate the fuel pump. Check the line fittings for leakage.
- e. Install the cowling.

9-27. CLEANING FUEL SYSTEM.

- a. To flush the fuel tanks and selector valve, disconnect the fuel line at the injector.
- b. Select a fuel tank, turn on the electric fuel pump and flush fuel through the system until it is determined there is no dirt and foreign matter in the fuel valve or tank. During this operation, agitation of the fuel within the tank will help pick up and remove any dirt.
- c. Repeat this procedure for each tank.
- d. When tanks are flushed, clean all filters.

CHEROKEE ARROW III SERVICE MANUAL

9-28. INSPECTION AND TIGHTENING OF FUEL LINE UNION FITTINGS.

- a. Remove the aft inboard inspection panel from the lower surface of the right and left wing.
- b. Remove the pilot's seat and left cabin side panel. Fold back the carpeting that covers the forward side of the spar box and remove the cover from the fuel line(s). On the PA-28R-201T, pull back the carpeting from the side of the cabin at the lower aft corner of the door to gain access to the 1/4" fuel vent tubing.
- c. Inspect all union fittings used in the fuel system for signs of leakage. Note any leaking fittings for later recheck.
- d. Using a torque wrench and tubing crow's feet, carefully tighten each union fitting to the torques listed below:

Tube Size	Applied Torque	
1/4 in. OD 3/8 in. OD	75-95 inch-pounds 175-195 inch-pounds	Using a Tubing Crow's Foot

CAUTION

Using a crow's foot adapter other than a tubing type will result in deformation or severe damage to the union nut and will probably cause a leak which will require replacement of the union and tubing.

NOTE

If during the torque check a galled nut and union are suspected, back off the nut and inspect the threads. If the union is serviceable, apply a thread lube such as Slip Spray Lubricant (DuPont) or Ferrulube (Parker-Hannifin) and torque the nut to the proper values as listed in step d. If the union is unserviceable, it must be replaced per instructions given in paragraph titled Replacement of Fittings following this paragraph.

When applying thread lubricant, ensure its application to the male connector threads only. Care should be taken that no lubricant enters the throat of the connector seat or contacts the ferrule seat face.

- e. After torquing each fitting, measure the distance between the face of the union nut and face of tubing nut. Refer to Figure 9-8 for tolerance.
- f. Any fitting found out of tolerance must be replaced in accordance with instructions given in paragraph titled Replacement of Fittings.
- g. After all unions have been checked for proper tightness and all repairs (if any) have been made, ensure that the airplane is full of fuel and run the engine for three to five minutes on each tank. Ensure engine operation in a safe manner and location.
- h. After engine shut down, wiggle all unions. If any fittings are found leaking, repairs must be accomplished in accordance with paragraph titled Replacement of Fittings.
- i. When system is found leak free, replace the side panel, carpet, access plates and seat.
- j. Make an appropriate logbook entry.

CHEROKEE ARROW III SERVICE MANUAL

9-29. REPLACEMENT OF FITTINGS.

NOTE

Defueling of airplane may be required for union and/or tubing replacement.

- a. If fittings show evidence of galling, or does not meet the dimensional requirements of Figure 9-8 or continues to leak after being tightened, it must be repaired.
- b. The recommended repair is to remove the leaking union and replace it using a standard AN fitting as outlined in AC43.13-1A, paragraph 392. This will require cutting off the swaged ferrule and adding a short length of tubing.
- c. If a replacement tube and union purchased from Piper is being used, the ferrule is pre-swaged onto the tube. Install the pre-fabricated tube as follows:
 1. Apply a thread lube as recommended in step d of paragraph titled Inspection and Tightening of Fuel Line Union Fittings to the threads of the union.
 2. Carefully align the tube into the union and snug up the nut using a wrench.
 3. Then using the wrench, tighten the nut one to two flats ($1/6$ to $1/3$ of a turn).
- d. If a repair is being made using a Parker-Hannifin unions and tubes without pre-swaged ferrules they should be installed as follows:
 1. Cut off the tubing at a convenient location back from the fitting.
 2. De-burr the end of the tube and prepare a short length of tube to splice into the line.
 3. Screw the nut and ferrule onto the union until solidly finger tight.
 4. Insert the tubes into the unions, being careful to ensure proper straight alignment of the tubing and union.
 5. Using a tubing wrench, tighten the nut one and one-quarter ($1-1/4$) turns.
- e. After corrective action has been completed, perform leak test as outlined in steps g and h of paragraph titled Inspection and Tightening of Fuel Line Union Fittings.

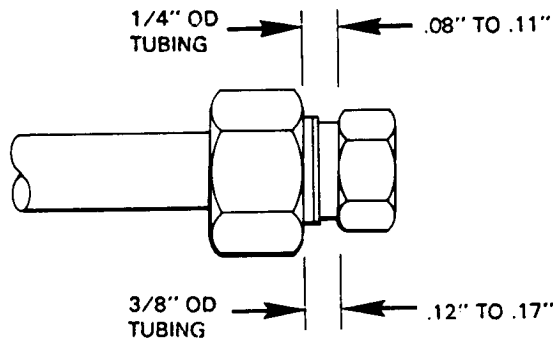

Figure 9-8. Tolerances, Union Nut and Tubing Nut

CHEROKEE ARROW III SERVICE MANUAL

TABLE VIX-IV. TROUBLESHOOTING CHART. (FUEL SYSTEM)

Trouble	Cause	Remedy
Failure of fuel to flow.	Fuel line blocked. Fuel vent cap blocked. Mechanical or electrical fuel pump failure. Fuel selector valve in improper position. Damaged fuel selector valve.	Flush fuel system. Check and clean vent hole in cap. Check and replace if necessary. Reposition as required. Replace fuel selector valve.
Fuel quantity gauge fails to operate.	Broken wire. Gauge inoperative. Circuit breaker open. Float and arm assembly of fuel sender sticking. Bad ground.	Check and repair. Replace gauge. Check and reset. Check. Check for good contact at ground lip or rear of gauge.

CHEROKEE ARROW III SERVICE MANUAL

TABLE VIX-IV. TROUBLESHOOTING CHART. (FUEL SYSTEM) (cont)

Trouble	Cause	Remedy
<p>No fuel pressure indication.</p>	<p>Fuel selector valve stuck.</p> <p>Fuel tanks empty.</p> <p>Defective pump.</p> <p>Defective gauge.</p> <p>Fuel selector valve in improper position.</p>	<p>Check fuel selector valve.</p> <p>Check fuel tanks and fill.</p> <p>Replace pump.</p> <p>Replace gauge.</p> <p>Reposition fuel selector valve lever.</p>
<p>Low pressure or pressure surges.</p>	<p>Obstruction in inlet side of pump.</p> <p>Air in line to pressure gauge.</p>	<p>Trace lines and locate obstruction.</p> <p>Bleed line.</p>
<p>NOTE</p> <p><i>Refer to Table VIII-III for additional Fuel Troubleshooting on PA-28R-201T airplanes.</i></p>		

SECTION X

INSTRUMENTS

Paragraph	Aerofiche Grid No.
10-1. General	2F8
10-2. Non-Electrical Instruments.....	2F8
10-3. Vacuum System Description and Operation.....	2F8
10-4. Vacuum System Service Tips	2F8
10-5. Hoses and Clamps	2F8
10-6. Vacuum Gauges.....	2F9
10-7. Gyro Filters.....	2F9
10-8. Vacuum Regulator.....	2F10
10-9. Engine Driven Vacuum Pump.....	2F10
10-10. Removal of Engine Driven Vacuum Pump	2F10
10-11. Installation of Engine Driven Vacuum Pump.....	2F10
10-12. Auxiliary Vacuum Pump	2F15
10-13. Vacuum Regulator Valve.....	2F18
10-14. Adjustment of Vacuum Regulator Valve.....	2F18
10-15. Removal and Replacement of Regulator Valve.....	2F18
10-16. Suction Gauge	2F20
10-17. General	2F20
10-18. Troubleshooting.....	2F20
10-19. Pitot-Static System	2F21
10-20. Directional Gyro.....	2F22
10-21. General	2F22
10-22. Troubleshooting.....	2F22
10-23. Removal and Replacement.....	2F23
10-24. Gyro Horizon.....	2F23
10-25. General	2F23
10-26. Troubleshooting.....	2F23
10-27. Removal and Replacement.....	2F23
10-28. Rate of Climb Indicator.....	2F23
10-29. General	2F23
10-30. Troubleshooting.....	2F24
10-31. Removal and Replacement.....	2G1
10-32. Sensitive Altimeter.....	2G1
10-33. General	2G1
10-34. Troubleshooting.....	2G1
10-35. Removal and Replacement.....	2G3

Paragraph	Aerofiche Grid No.
10-36. Airspeed Indicator	2G3
10-37. General	2G3
10-38. Troubleshooting.....	2G3
10-39. Removal and Replacement.....	2G4
10-40. Magnetic Compass	2G4
10-41. General	2G4
10-41a. Adjustment of Compass	2G4
10-42. Troubleshooting.....	2G5
10-43. Manifold Pressure Gauge.....	2G6
10-44. General	2G6
10-45. Troubleshooting.....	2G6
10-46. Removal and Replacement.....	2G6
10-47. Tachometer Indicator.....	2G7
10-48. General	2G7
10-49. Troubleshooting.....	2G7
10-50. Removal and Replacement.....	2G7
10-51. Engine Oil Pressure Gauge.....	2G8
10-52. General	2G8
10-53. Troubleshooting.....	2G8
10-54. Removal and Replacement.....	2G8
10-55. Fuel Pressure Gauge.....	2G8
10-56. General	2G8
10-57. Troubleshooting.....	2G9
10-58. Removal and Replacement.....	2G9
10-59. Electrical Instruments.....	2G10
10-60. Turn and Bank Indicator.....	2G10
10-61. General	2G10
10-62. Troubleshooting.....	2G10
10-63. Removal and Replacement.....	2G10
10-64. Fuel Quantity Indicator.....	2G10
10-65. General	2G10
10-66. Troubleshooting.....	2G11
10-67. Removal and Replacement.....	2G11
10-68. Oil Temperature Indicator	2G11
10-69. General	2G11
10-70. Troubleshooting.....	2G12
10-71. Removal and Replacement.....	2G12
10-72. Ammeter.....	2G12
10-73. General	2G12
10-74. Troubleshooting.....	2G12
10-75. Removal and Replacement.....	2G12

Paragraph	Aerofiche Grid No.
10-76. Removal and Replacement of Face Mounted Instruments.....	2G12
10-77. General	2G12
10-78. Removal and Replacement of Cluster Mounted Instruments.....	2G13
10-79. General	2G13
10-80. Gyro Fitting Installation Procedure.....	2G13
10-81. Cylinder Head Temperature Gauge.....	2G13
10-82. General	2G13
10-83. Troubleshooting.....	2G14
10-84. Removal and Replacement.....	2G14
10-85. Piper Auto Control System.....	2G14
10-86. Annunciator Panel.....	2G14
10-87. General	2G14
10-88. Troubleshooting.....	2G14
10-89. Removal and Replacement.....	2G14

CHEROKEE ARROW III SERVICE MANUAL

SECTION X

INSTRUMENTS

WARNING

When servicing or inspecting vendor equipment installed in Piper aircraft, it is the user's responsibility to refer to the applicable vendor publications.

10-1. GENERAL. The instrumentation is designed to give a quick and actual indication of the attitude, performance and condition of the airplane. Maintenance, other than described in these sections, shall be done by the instrument manufacturer or an authorized repair station.

The two types of instruments have been classified in this section as non-electrical and electrical. The first part of this section will pertain to maintenance and troubleshooting of all the instruments and their systems which depend on non-electrical sources for their operation.

10-2. NON-ELECTRICAL INSTRUMENTS.

10-3. VACUUM SYSTEM DESCRIPTION AND OPERATION. The following information is provided to familiarize field service personnel with a means to diagnose vacuum systems malfunctions on those components which are serviced by removal or replacement, along with recommended service practices. This system operates the gyro instruments and consists of an engine driven dry vacuum pump, a vacuum regulator and filter, and necessary hoses and lines that connect these components. Serial numbers 2837001 and up of the PA-28R-201 and serial numbers 2803001 and up of the PA-28R-201T have auxiliary electrically operated dry vacuum pumps incorporated in the system that provides a back-up source to operate the gyro flight instruments if the engine driven pump fails. A vacuum gauge is used to constantly monitor the system.

CAUTION

DO NOT USE PIPE DOPE or any anti-seize tape or compound. The AIRBORNE fittings are cadmium plated and need no other anti-seize materials. Any ingested anti-seize materials may cause premature system service. If a thread lubricant is required, use a powdered moly sulfide or graphite in dry form or in an evaporating vehicle; or employ a silicone spray. Apply sparingly to external threads of fittings only.

10-4. VACUUM SYSTEM SERVICE TIPS. (Refer to Table 10-1 for Troubleshooting Tips.)

CAUTION

Failure to inspect vacuum system hoses, clamps, and other components periodically for leaks and security, will result in unreliable gyro instrument indications.

10-5. HOSES AND CLAMPS. (Refer to Table 10-1 for Troubleshooting Instructions.)

- a. Hoses and clamps should be examined periodically and inspected carefully when engine maintenance activities cause hose disconnections to be made at the pump(s), regulating valve, gyro instruments, or vacuum gauge.

CHEROKEE ARROW III SERVICE MANUAL

CAUTION

Slivers of rubber from the hoses can become detached and sucked into the pump, causing damage and a shorter pump life.

- b. Examine the ends of the hoses for rubber separation and slivers on the inside diameter. The slivers can detach, enter the vacuum pump, filter, and cause premature pump service.
- c. Replace any hoses, clamps, or fittings that are broken, damaged, or corroded.

CAUTION

Immediately plug holes with shipping plugs after removing any component, opening any line, or removing any gyro instrument, or warranty will be voided due to contamination.

10-6. VACUUM GAUGES. (Refer to Table 10-1 for Troubleshooting Instructions.)

NOTE

Vacuum gauges are replaced when malfunctions occur. The failure of the gauge does not impair safety of flight.

- a. If the vacuum gauge malfunctions in a manner to cause an incorrect reading in normal cruise power conditions, the gauge must be checked by comparing the reading with a gauge of known accuracy. If the gauge is indicating correct and the system vacuum level is not in accordance with the specific vacuum; then and only then should the regulator be adjusted.
- b. Visually examine gauge performance as follows:
 1. When the engine not operating and no vacuum is applied to the gauge, the pointer on the gauge should rest against the internal stop in the 9 o'clock position. If the gauge pointer appears in any other position, the gauge is faulty and requires replacement.
 2. A slight overshoot during engine startup, not to exceed one half inch of mercury is normal and is not cause to replace the gauge.
 3. With the engine running at normal cruise power rpm, the indication on the gauge should read 4.8 to 5.2 inches of mercury.
 4. At 1200 rpm, the vacuum gauge indication should read in excess of four inches of mercury.

10-7. GYRO FILTERS. (Refer to Table 10-1 for Troubleshooting Instructions.)

CAUTION

Service gyro filters per Piper recommended scheduled basis, but no later than 100 hours, or sooner as conditions may require. Operations in dusty conditions, or if heavy concentrations of smoking occur in the aircraft, are conditions that warrant sooner inspection considerations.

NOTE

The vacuum system has a large central filter and a differential vacuum gauge that monitors the filter condition while gaining vacuum indication.

CAUTION

The central filter combined with a differential vacuum gauge will give a decline in panel gauge indication when filter is clogged and vacuum declines below recommended adjustment settings. Filters should be replaced when gauge indication declines below the recommended adjustment setting; do not readjust the regulator because accurate adjustment can only be obtained with clean system filters.

10-8. VACUUM REGULATOR. (Refer to Table 10-1 for Troubleshooting Instructions.)

The vacuum regulator is mounted up under the instrument panel for easy maintenance access.

CAUTION

If the gauge is found to be accurate, all filters clean, and the vacuum gauge still does not indicate within 4.8 to 5.2 inches of mercury range, the regulator valve must be replaced.

- a. Symptoms that indicate regulator replacement are:
 1. Rapid fluctuation of the vacuum gauge indication pointer.
 2. Audible sound or chatter with fluctuation indication.
 3. Non-repeatability of vacuum gauge indication when gauge is not suspect.

NOTE

Regulator malfunctions tend to increase vacuum power to the gyro instruments. Although this excess of vacuum is applied, a loss of vacuum does occur. Gyro instruments themselves act as limiting devices to keep vacuum power from exceeding safe limits.

10-9. ENGINE DRIVEN VACUUM PUMP. (Refer to Table 10-1 for Troubleshooting Tips.) The engine driven vacuum is a dry rotary vane positive displacement type, located on the rear accessory section of the engine. It consists of an aluminum housing that contains a tempered sleeve in which an offset rotor is incorporated. The assembly is driven by a series of engine driven gears mated to a coupling on the pump

10-10. REMOVAL OF ENGINE DRIVEN VACUUM PUMP.

- a. Remove top engine cowling. (Refer to Chapter 71.)
- b. Loosen hose clamp and remove hose from pump fitting.
- c. Remove the four retainer nuts, lockwashers, plain washers that secure the pump to the accessory section of the engine.
- d. Remove the pump, plug the open hose and cap the open pump line.

10-11. INSTALLATION OF ENGINE DRIVEN VACUUM PUMP.

CAUTION

Never install a pump that has been dropped or damaged.

CHEROKEE ARROW III SERVICE MANUAL

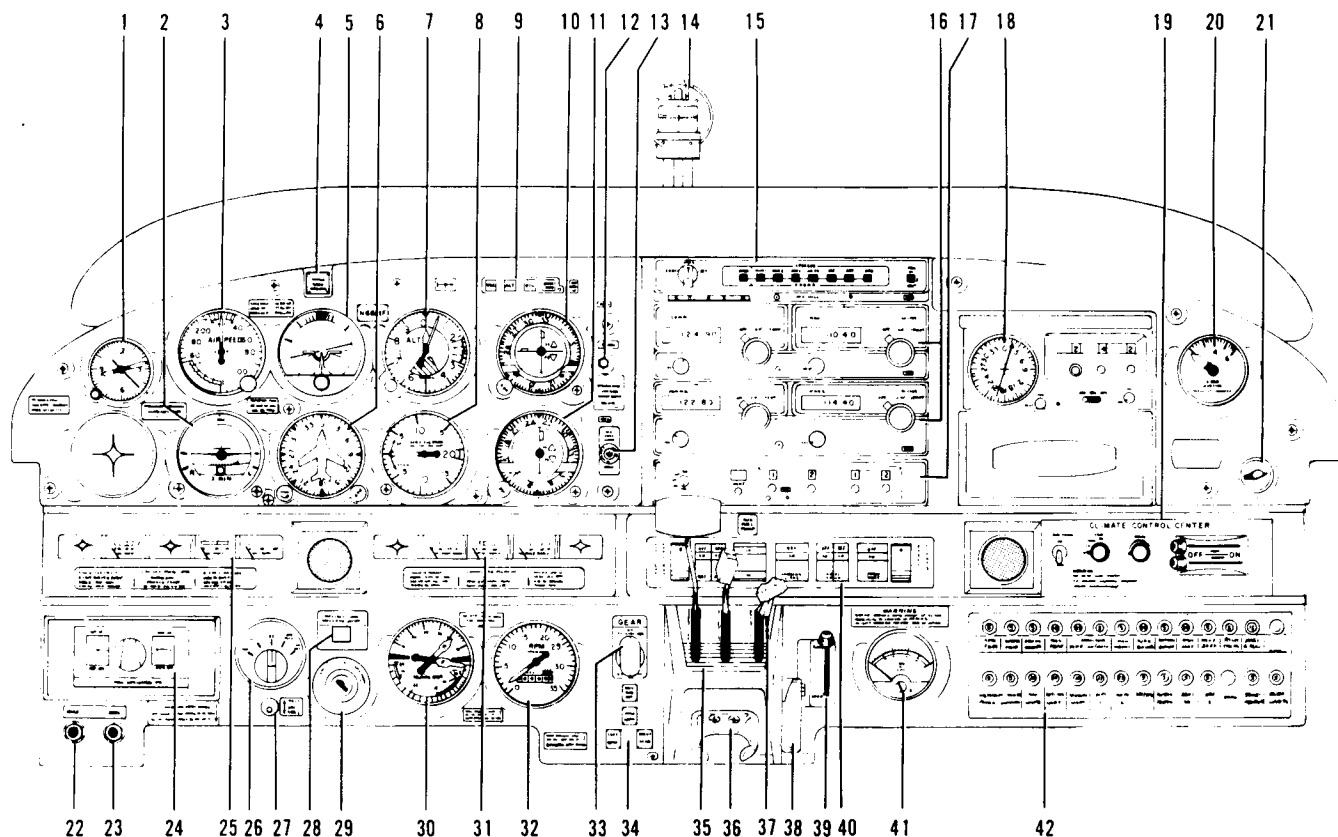

- | | | |
|---|---|---|
| <ol style="list-style-type: none"> 1. CLOCK 2. TURN COORDINATOR 3. AIRSPEED INDICATOR 4. WARNING - GEAR UNSAFE LIGHT 5. ATTITUDE GYRO 6. DIRECTIONAL GYRO 7. ALTIMETER 8. VERTICAL SPEED INDICATOR 9. ANNUNCIATOR DISPLAY 10. OMNI AND GLIDE SLOPE INDICATOR 11. OMNI INDICATOR 12. PRIMER BUTTON 13. AIR CONDITIONER DOOR LIGHT 14. COMPASS 15. AUDIO CONTROL PANEL | <ol style="list-style-type: none"> 16. COMMUNICATIONS TRANSCEIVERS 17. TRANSPONDER 18. ADF 19. CLIMATE CONTROL CENTER 20. GYRO SUCTION GAUGE 21. CIGAR LIGHTER 22. MIKE JACK 23. PHONE JACK 24. AUTOPILOT - AUTOCONTROL IIIB 25. CLUSTER GAUGES 26. OMNI COUPLER 27. NAV 1, NAV 2 SWITCH 28. ELECTRICAL TRIM SWITCH 29. IGNITION SWITCH | <ol style="list-style-type: none"> 30. MANIFOLD PRESSURE/ FUEL FLOW GAUGE 31. CLUSTER GAUGE 32. TACHOMETER 33. GEAR SELECTOR SWITCH 34. GEAR INDICATOR LIGHTS 35. CONTROL QUADRANT 36. MIKE ATTACHMENT 37. MIXTURE CONTROL LOCK 38. FRICTION LOCK 39. ALTERNATE AIR 40. CONTROL SWITCHES 41. EGT 42. CIRCUIT BREAKER PANEL |
|---|---|---|

Figure 10-1, Instrument Panel (Typical)

CHEROKEE ARROW III SERVICE MANUAL

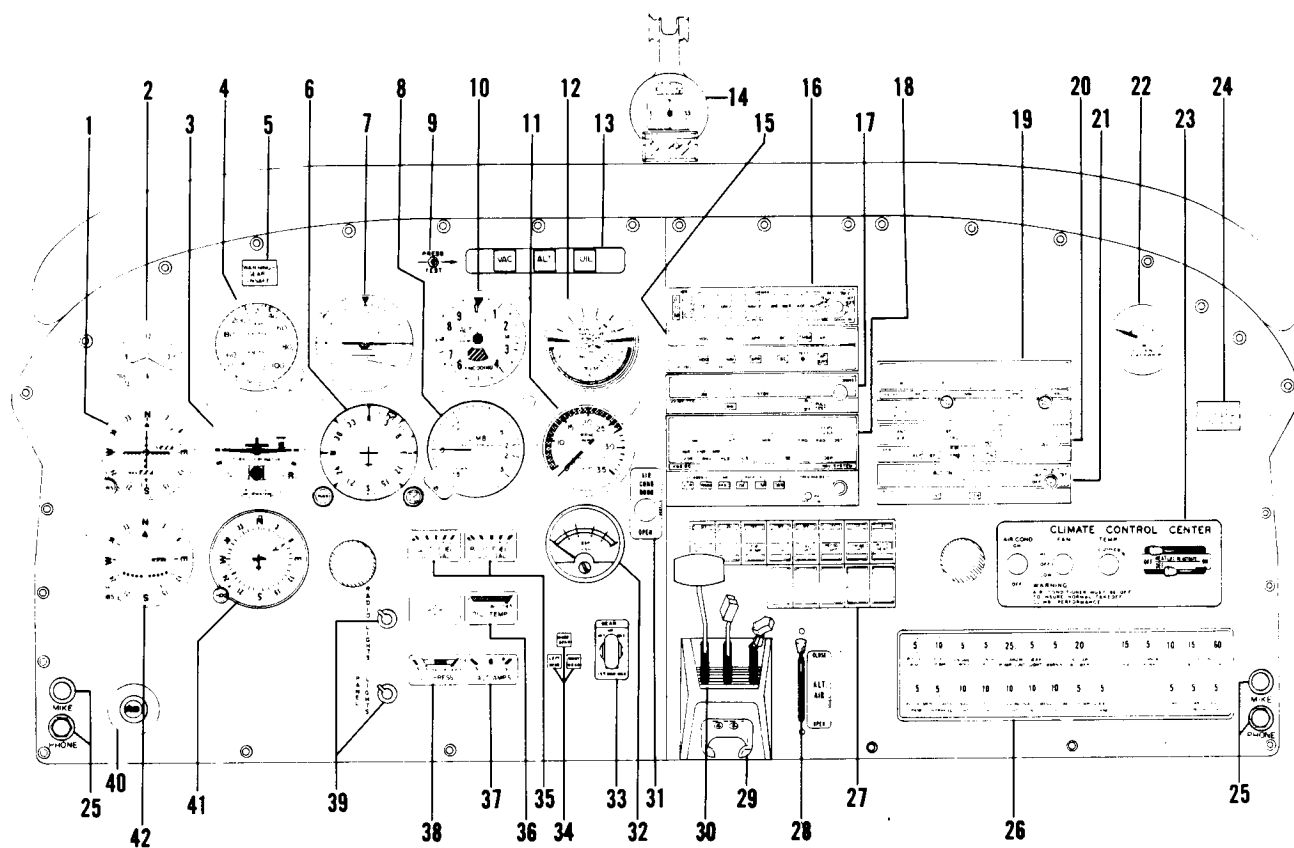

PA28R-201 ARROW

- | | | |
|--|--|--|
| <ol style="list-style-type: none"> 1. VOR/LOC/GLIDESLOPE INDICATOR 2. CLOCK 3. TURN COORDINATOR 4. AIRSPEED INDICATOR 5. WARNING - GEAR UNSAFE LIGHT 6. DIRECTIONAL GYRO 7. ATTITUDE GYRO 8. VERTICAL SPEED INDICATOR 9. ANNUNCIATOR TEST SWITCH 10. ALTIMETER 11. TACHOMETER 12. MANIFOLD PRESSURE AND FUEL FLOW/PRESSURE GAUGE 13. ANNUNCIATOR LIGHTS 14. MAGNETIC COMPASS | <ol style="list-style-type: none"> 15. AUTOPILOT 16. AUDIO CONTROL PANEL 17. COMMUNICATIONS TRANSCEIVER 18. AREA NAVIGATION RECEIVER 19. NAVIGATION/COMMUNICATIONS TRANSCEIVER 20. ADF RECEIVER 21. RADAR TRANSPONDER 22. GYRO SUCTION GAUGE 23. CLIMATE CONTROL CENTER 24. HOUR METER 25. MIKE/PHONE JACKS 26. CIRCUIT BREAKERS 27. ELECTRICAL SWITCHES 28. ALTERNATE AIR CONTROL | <ol style="list-style-type: none"> 29. MICROPHONE HOLDER 30. ENGINE CONTROLS QUADRANT 31. AIR CONDITIONER DOOR LIGHT 32. E.G.T. GAUGE 33. LANDING GEAR SELECTOR 34. LANDING GEAR POSITION 35. LEFT AND RIGHT FUEL GAUGES 36. OIL TEMPERATURE GAUGE 37. AMMETER 38. OIL PRESSURE GAUGE 39. RADIO/SWITCH/INSTRUMENT LIGHTS CONTROL 40. IGNITION (MAGNETO) SWITCH 41. RADIO COMPASS (ADF) 42. VOR/LOC INDICATOR |
|--|--|--|

Figure 10-1a. Instrument Panel (PA-28R-201 S/N 2837001 and up)

CHEROKEE ARROW III SERVICE MANUAL

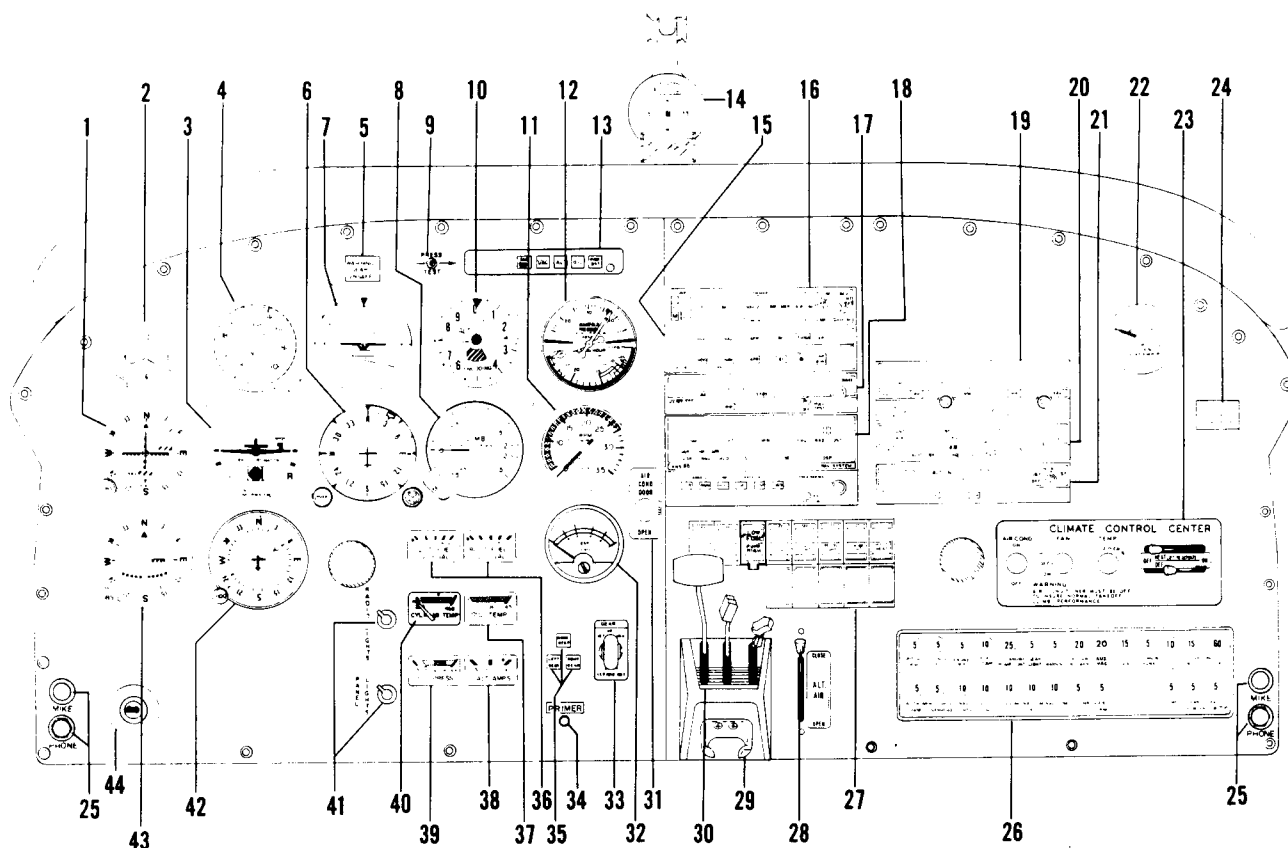

PA28R-201T ARROW TURBO

- | | | |
|--|--|--|
| <ul style="list-style-type: none"> 1. VOR/LOC/GLIDESLOPE INDICATOR 2. CLOCK 3. TURN COORDINATOR 4. AIRSPEED INDICATOR 5. WARNING - GEAR UNSAFE LIGHT 6. DIRECTIONAL GYRO 7. ATTITUDE GYRO 8. VERTICAL SPEED INDICATOR 9. ANNUNCIATOR SPEED INDICATOR 10. ALTIMETER 11. TACHOMETER 12. MANIFOLD PRESSURE AND FUEL FLOW/PRESSURE GAUGE 13. ANNUNCIATOR LIGHTS 14. MAGNETIC COMPASS | <ul style="list-style-type: none"> 15. AUTOPILOT 16. AUDIO CONTROL PANEL 17. COMMUNICATIONS TRANSCEIVER 18. AREA NAVIGATION RECEIVER 19. NAVIGATION/COMMUNICATIONS TRANSCEIVER 20. ADF RECEIVER 21. RADAR TRANSPONDER 22. GYRO SUCTION GAUGE 23. CLIMATE CONTROL CENTER 24. HOUR METER 25. MIKE/PHONE JACKS 26. CIRCUIT BREAKERS 27. ELECTRICAL SWITCHES 28. ALTERNATE AIR CONTROL | <ul style="list-style-type: none"> 29. MICROPHONE HOLDER 30. ENGINE CONTROLS QUADRANT 31. AIR CONDITIONER DOOR LIGHT 32. E.G.T. GAUGE 33. LANDING GEAR SELECTOR 34. ENGINE PRIMER 35. LANDING GEAR POSITION 36. LEFT AND RIGHT FUEL GAUGES 37. OIL TEMPERATURE GAUGE 38. AMMETER 39. OIL PRESSURE GAUGE 40. CYLINDER HEAD TEMPERATURE GAUGE 41. RADIO/SWITCH/INSTRUMENT LIGHTS CONTROL 42. RADIO COMPASS (ADF) 43. VOR/LOC INDICATOR 44. IGNITION (MAGNETO) SWITCH |
|--|--|--|

Figure 10-1b. Instrument Panel (PA-28R-201T S/N 2803001 and up)

CHEROKEE ARROW III SERVICE MANUAL

- 1. ALTIMETER
- 2. VERTICAL SPEED INDICATOR
- 3. AIRSPEED INDICATOR
- 4. STATIC SOURCE PICKUP
- 5. HEATED PITOT SWITCH (OPTIONAL)
- 6. ALTERNATE STATIC SOURCE VALVE
- 7. PITOT AND STATIC DRAINS
- 8. PITOT HEAD

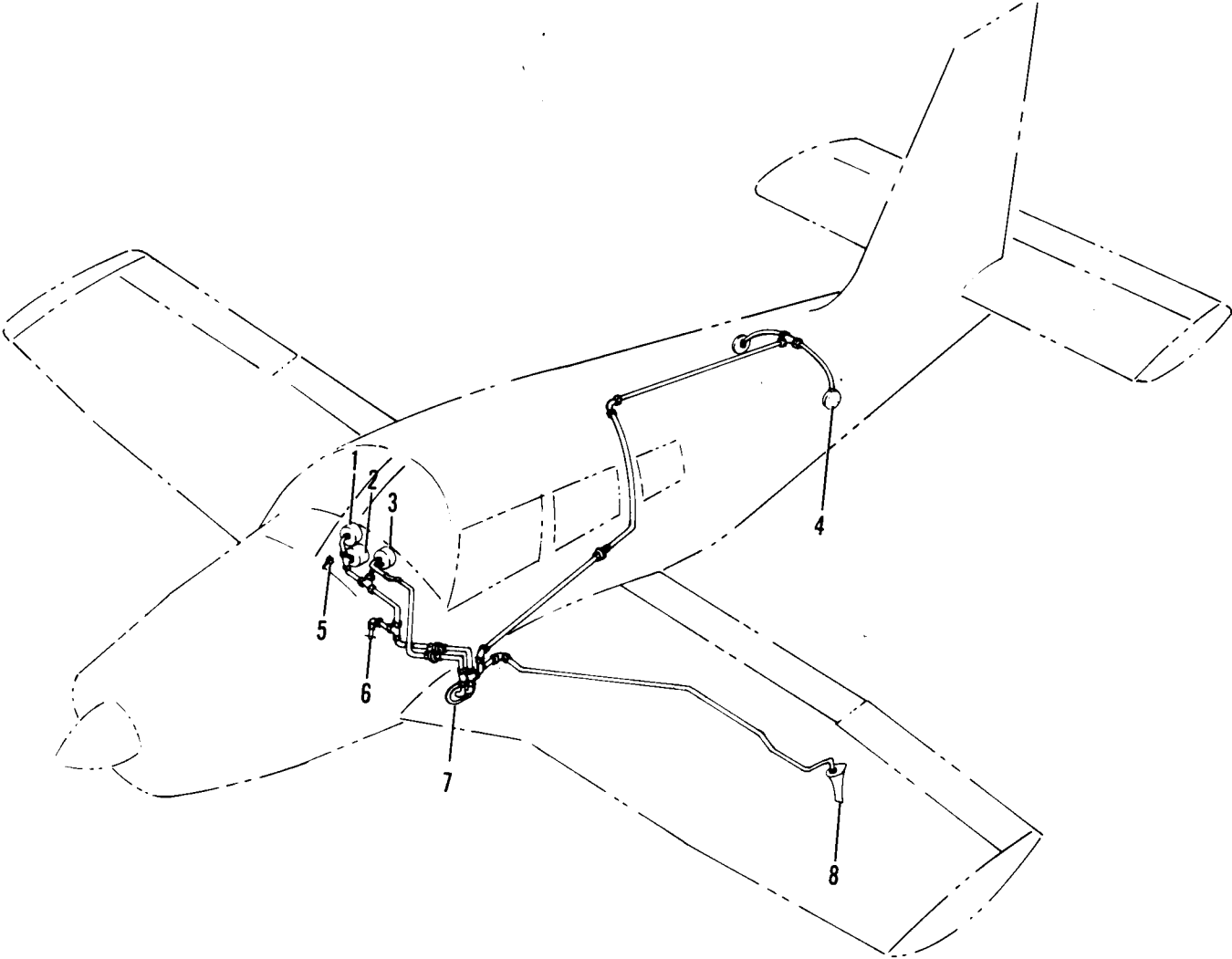

Figure 10-2. Pitot Static System

CHEROKEE ARROW III SERVICE MANUAL

- a. Before installing any fittings on the pump, check for thread damage.

CAUTION

Do not secure the pump in the raw steel jaws of a vice for installation of fittings. Caution must be taken to avoid pump damage by installing protective sleeves to the vice and using only enough pressure to hold the pump firmly. Do not apply vise pressure to the outside diameter or overall length of the pump.

- b. With the pump properly secured, insert fittings into the ports and hand tighten firmly; then using a wrench, tighten each fitting from one-half to two additional turns.

CAUTION

The only pump mounting gasket authorized and approved for use on the AIRBORNE vacuum pump is AIRBORNE gasket B3-1-2, Piper Part Number 751 859. Any other gasket could result in oil seepage or leakage at the mounting flange.

- c. Place pump gasket in place and align spline on pump drive with spline on engine drive assembly.
- d. Secure pump to engine with four plain washers, lockwashers, and retaining nuts.
- e. Tighten the four nuts to a torque of 50 to 70 inch-pounds.
- f. Snug one locknut on each of the four retaining nuts.
- g. Remove all plugs and caps from the fittings and hoses and secure the hoses to the pump with clamps.
- h. After a functional operation check, replace the top cowling.

10-12. AUXILIARY VACUUM PUMP (Serial Numbers 2837001 and up of PA-28R-201 and 2803001 and up of PA-28R-201R models). (Refer to Table 10-1 for Troubleshooting Instructions.)

CAUTION

When replacement of the auxiliary pump is required, the complete pump and motor must be replaced with a new operational unit. It is important that repair is made by authorized maintenance personnel only for proper operation.

- a. The auxiliary vacuum pump is mounted on the right side of the firewall and serves as a backup to the engine operated pump if it should fail to operate the gyro instruments. There is a 20 amp circuit breaker in the system that protects the pump motor and a 5 amp circuit breaker that protects the annunciator light switch.
- b. Auxiliary Vacuum Pump Engine Off Operational Check.

CAUTION

Excessive running of the auxiliary pump will weaken the battery to an unreliable charge level. Ensure that all electrical equipment is off before beginning engine off operational check. Operate system as short a time as possible.

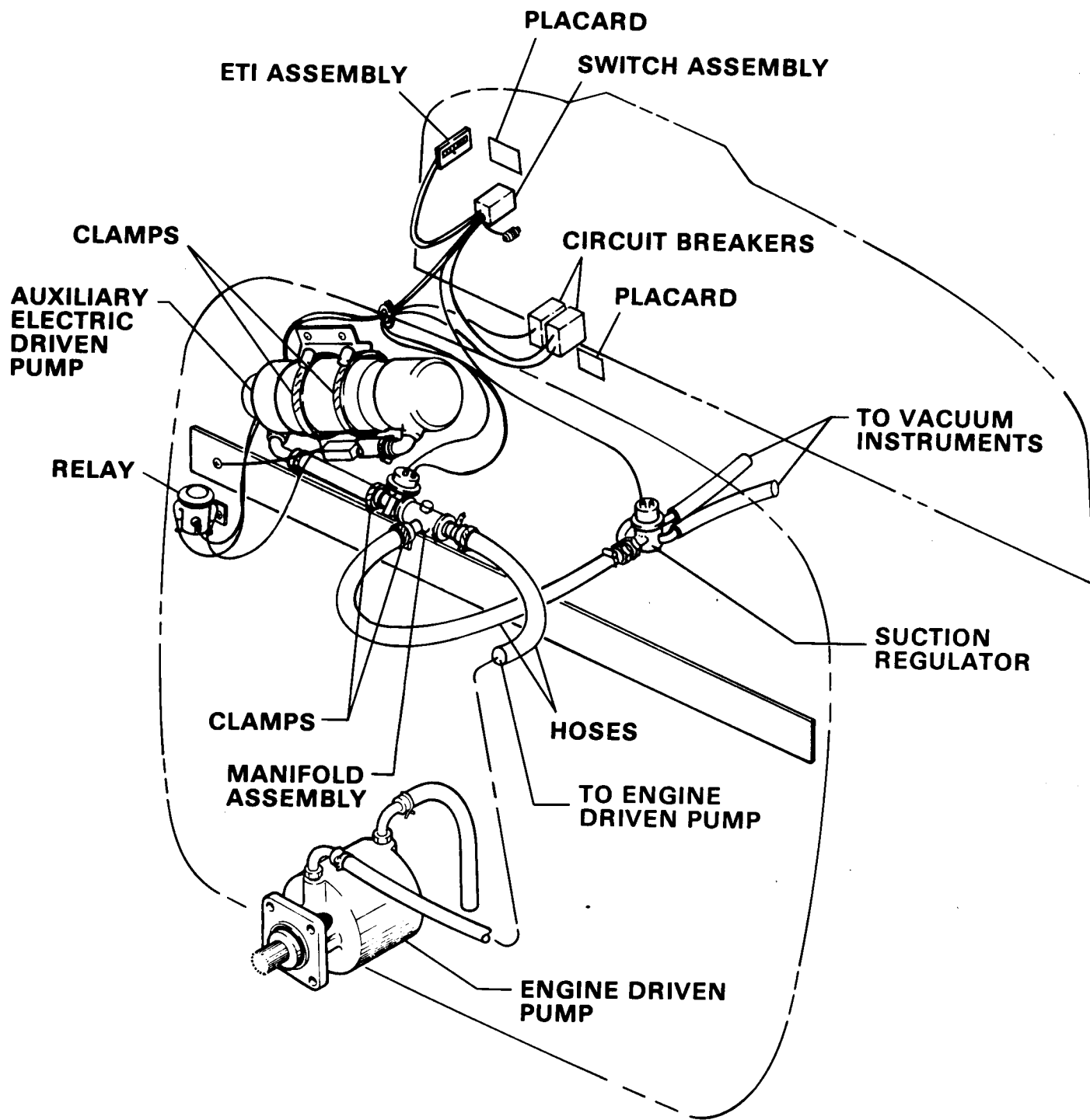

Figure 10-3. Vacuum-Auxiliary Vacuum Installation

CHEROKEE ARROW III SERVICE MANUAL

1. Press battery master switch ON. Check the VAC OFF annunciator illuminates.
 2. Press VAC OFF/AUX ON annunciator switch. Ensure that AUX ON annunciator illuminates and VAC OFF annunciator goes out. Observe that the vacuum gauge indicates between 4.8 and 5.2 in. Hg.
 3. Press VAC OFF/AUX ON annunciator switch to cycle it to the OFF position. Ensure that AUX ON annunciator goes out and VAC OFF annunciator illuminates.
 4. Press the battery master switch to OFF.
- c. Removal of Auxiliary Vacuum Pump.

WARNING

Verify that the battery master switch is in the OFF position.

CAUTION

The auxiliary vacuum pump and motor are one sealed assembly and must be removed and replaced with another sealed assembly. The elapsed time indicator is matched to the pump/motor assembly and must be removed and replaced with the pump/motor assembly as one unit. Insulate and secure all electrical leads that remain loose, if replacement is not installed immediately.

1. Remove the top cowling.
 2. Disconnect hoses from pump/motor assembly.
 3. Disconnect electrical leads at terminals of the pump/motor assembly.
 4. Insulate and secure disconnected electrical leads.
 5. Loosen the band clamps and remove pump/motor from firewall brackets.
 6. Locate the elapsed time indicator under the right instrument panel; disconnect the electrical leads.
 7. Remove the elapsed time indicator.
 8. Insulate and secure the electrical leads at the elapsed time indicator.
 9. If a replacement auxiliary pump is not installed now, place protective plugs or caps over open ends of vacuum hoses and secure them. Install the top cowling.
- d. Installation of Auxiliary Vacuum Pump Assembly.

WARNING

Verify that the battery master switch is OFF.

CAUTION

Never install an auxiliary pump assembly that has been dropped or damaged. The matched elapsed time indicator must be installed with the matched pump/motor assembly.

1. Remove temporary insulators and connect elapsed time indicator to two-pin connector on the leads coming from the back of the switch, at rear right side of instrument panel.
2. Secure elapsed time indicator to wire harness with a strap (zip strip). Ensure that elapsed time indicator can be easily located and inspected.

3. Secure all excess lead wire.
4. Now remove the top engine cowling.
5. Mount auxiliary vacuum pump/motor assembly with band clamps. Do not tighten the clamps at this time because adjustments may be necessary.
6. Attach and secure electrical leads to terminals on pump/motor assembly.
7. Measure hoses to obtain proper length. Allow some slack, then cut as necessary.
8. Remove all caps and plugs then attach and secure hoses to ports on pump/motor assembly.
9. Position pump/motor assembly per Figure 10-3 instructions.
10. Tighten clamps and install engine top cowling.

10-13. VACUUM REGULATOR VALVE. (Refer to Table X-I for Troubleshooting Instructions.) One vacuum regulator valve is incorporated in the system to control vacuum pressure to the gyro instruments. The regulator valve is located under the instrument panel. Access to the valve for maintenance and adjustment is gained from below the instrument panel.

10-14. ADJUSTMENT OF VACUUM REGULATOR VALVE.

WARNING

Do not attempt adjustment of this valve with engine in operation. This procedure may be done with the engine running provided a qualified pilot or maintenance person is at the controls, but is considered dangerous and not recommended by Piper.

CAUTION

Before any adjustments are made to the vacuum regulator, verify that the system filters and lines are clean.

- a. Bend locking tabs up (if applicable) then loosen locking nut or remove protective cap from valve per type installed.
- b. Start the engine and allow for engine warm-up at a medium rpm setting.
- c. With the engine running at medium rpm, the suction gauge should indicate 5.0 ± 0.2 inches of mercury. If the indication is not within this range, shut down the engine and adjust regulator (clockwise to increase pressure or counterclockwise to decrease pressure).
- d. Again, start the engine and repeat this procedure until an indication of 5.0 ± 0.2 inches of mercury is obtained at a medium power setting.

NOTE

If airplane is not equipped with a suction gauge, connect a temporary gauge of known accuracy by removing the plug from back of the artificial horizon and attaching it there.

- e. After satisfied that pressure is adjusted correctly to 5.0 ± 0.2 inches of mercury, remove gauge and install plug; replace protective cap and tighten locknut per type valve installed.

10-15. REMOVAL AND REPLACEMENT OF REGULATOR VALVE.

- a. Disconnect the three lines and remove mounting nut. Remove valve from airplane.
- b. Install regulator in reverse order of removal.
- c. Verify that complete vacuum system is operational.

CHEROKEE ARROW III SERVICE MANUAL

TABLE X-I. TROUBLESHOOTING CHART (VACUUM SYSTEM)

Trouble	Cause	Remedy
No vacuum gauge indication at instrument.	Open vacuum line.	Locate and repair.
	Faulty instrument.	Replace.
No vacuum gauge indication at instrument of source.	Faulty gauge or malfunctioning pump.	Replace gauge or replace pump.
Low vacuum system indication.	Filter dirty.	Clean or replace filter.
	Vacuum regulator valve not adjusted properly.	Adjust regulator valve per adjustments in this section.
	Gyro to filter line restricted.	Repair or replace line.
	Pump to gyros line leaking.	Check all lines and fittings.
Abnormal gyro precession - vacuum gauge reading correct or a maximum pressure.	Dirty filter.	Replace filter first, then adjust regulator.
Normal vacuum indication but sluggish operation of instruments.	Faulty instrument.	Replace instrument.
	Dirty or clogged filter or vacuum line kinked.	Replace filter. Replace damaged lines.
High system vacuum.	Vacuum regulator incorrectly adjusted.	Adjust regulator.
	Dirty or clogged filter.	Replace filter.
	Vacuum lines kinked or restricted.	Repair or replace lines.
	Vacuum regulator sticking or dirty screen.	Clean and check operation of regulator.
Regulator cannot be adjusted for correct vacuum pressure.	Lines leaking.	Check lines and fittings.
	Vacuum pump malfunctioning.	Replace pump.
Vacuum connect on ground but not normal at altitude.	Vacuum pump malfunctioning.	Replace pump.
	Regulator sticky.	Clean or replace regulator.

CHEROKEE ARROW III SERVICE MANUAL

TABLE X-I. TROUBLESHOOTING CHART (VACUUM SYSTEM) (cont)

Trouble	Cause	Remedy
Vacuum correct but pilot reports erratic indication of complete loss in flight.	Regulator sticky. Oil in pump due to leaky engine flange seal or cleaning fluid blown into pump while cleaning engine.	Clean regulator. Replace pump.
Vacuum can only be maintained at full throttle on ground.	Leak in system. Worn pump. Stuck regulator.	Repair or replace lines. Replace pump. Clean or replace regulator.
AUX ON selected on ground check and auxiliary vacuum pump will not run.	Circuit breaker open. Faulty electric motor. Faulty contactor. Loose or broken wire connections.	Reset circuit breaker(s). Isolate and check operation. Replace pump motor assembly if required. Tighten all wire connections and terminals. Check all wire for open breaks; repair as needed.
AUX ON selected on ground check and little or no vacuum is indicated. AUX ON annunciator will not illuminate.	Leak in vacuum system. Restriction in hose lines. Dirty filter. Faulty bulb. Regulator not adjusted properly.	Tighten clamps and check hoses. Replace if necessary. Inspect and repair hose lines. Replace if necessary. Replace filter. Replace bulb. Adjust properly.
VAC OFF AUX ON annunciator switch will not engage auxiliary vacuum pump system.	Open circuit breaker. Faulty switch.	Push circuit breaker(s) in. Test switch for operation. Replace if necessary.
Auxiliary vacuum pump maintains correct pressure on the ground but not at altitude.	Auxiliary vacuum pump is worn out. Regulator is sticky.	Replace auxiliary vacuum pump assembly. Clean or replace regulator.

CHEROKEE ARROW III SERVICE MANUAL

10-16. SUCTION GAUGE.

10-17. GENERAL. The suction gauge is mounted in the right side of the instrument panel to the left and up from the cigar lighter. This gauge is calibrated in inches of mercury and has a direct pressure line and vent line. Therefore, the gauge indicates the differential pressure or actual pressure being applied to the gyro instruments. As the system filter becomes clogged or lines obstructed, the gauge will show a decrease in pressure. Do not reset the regulator until the filter and lines have been checked.

10- 18. TROUBLESHOOTING. For troubleshooting of this instrument, refer to Table X-I of this section.

NOTE

For ease of pitot line installations in later models, changes of some lines have been made, but in no way change the design or operation of the system.

10-19. PITOT-STATIC SYSTEMS. (Refer to Figure 10-2.) Pitot pressure for the airspeed indicator is sensed by the pitot mast mounted under the left wing. Static pressure for the altimeter, vertical speed and airspeed indicators is sensed by two static pressure units, one located on each side of the rear part of the fuselage.

A drain is provided in the lower left front side panel to drain moisture from the pressure line running between the pitot mast and the instrument panel.

When installed, an alternate static source control valve is located below the instrument panel to the right of the power quadrant. If one or more of the pitot static instruments malfunctions these pressure systems should be checked for leaks, dirt or water. If moisture is present, the static system can be drained by turning on the alternate static system. The selector valve is located at the low point of the system.

At any time an instrument fitting, line, pitot head or static button is disconnected, tests must be performed prior to the next flight. Refer to AC43.13- 1 A for the testing procedures.

TABLE XI-II. DIRECTIONAL GYRO INDICATOR

Trouble	Cause	Remedy
Excess drift in either direction.	Setting error. Defective instrument. High or low vacuum. If vacuum is not correct, check for the following: a. Relief valve properly adjusted. b. Incorrect gauge reading. c. Pump failure. d. Vacuum line kinked of leaking.	Reset per paragraph 10-19. Replace instrument. a. Adjust. b. Replace gauge. c. Repair or replace. d. Check and repair. Check for collapsed inner wall or hose.
Dial spins during turn.	Limits (55° bank) of gimball exceeded.	Recage gyro in level flight.
Dial spins continuously.	Defective mechanism.	Replace.

CHEROKEE ARROW III SERVICE MANUAL

10-20. DIRECTION GYRO.

10-21. GENERAL. The directional gyro is a flight instrument incorporating an air driven gyro stabilized in the vertical plane. The gyro is rotated at high speed by lowering the pressure in the air tight case and simultaneously allowing atmospheric air pressure to enter the instrument against the gyro buckets. Due to gyroscopic inertia, the spin axis continues to point in the same direction even though the aircraft yaws to the right or left. This relative motion between the gyro and the instrument case is shown on the instrument dial which is similar to a compass card. The dial, when set to agree with the airplane magnetic compass provides a positive indication free from swing and turning error. However, the directional gyro has no sense of direction and must be set to the magnetic compass, since the magnetic compass is subject to errors due to magnetic fields, electric instruments, etc., the directional gyro is only accurate for the heading it has been set for. If the gyro is set on 270°, for instance, and the aircraft is turned to some other heading, there can be a large error between the gyro and the magnetic compass due to the error in compass compensation, the will appear as gyro precession. The gyro should only be checked on the heading on which it was first set, also due to internal friction, spin axis error, air turbulence and airflow, the gyro should be set at least every 15 minutes for accurate operation, whether it has drifted or not.

10-22. TROUBLESHOOTING.

TABLE X-II. GYRO HORIZON INDICATOR

Trouble	Cause	Remedy
Bar fails to respond.	Insufficient vacuum.	Check pump and tubing.
	Filter dirty.	Clean or replace filter.
Bar does not settle.	Insufficient vacuum.	Check line and pump. Adjust valve.
	Incorrect instrument.	Check part number.
	Defective instrument.	Replace.
Bar oscillates or shimmies continuously.	Instrument loose in panel.	Tighten mounting screws.
	Vacuum too high.	Adjust valve.
	Defective mechanism.	Replace instrument.

CHEROKEE ARROW III SERVICE MANUAL

TABLE X-III. GYRO HORIZON INDICATOR (cont)

Trouble	Cause	Remedy
Instrument tumbles in flight.	Low vacuum. Dirty filter. Line to filter restricted. Plug missing or loose in instrument	Reset regulator. Clean or replace filter. Replace line. Replace or tighten plug.
Instrument does not indicate level flight.	Instrument not level in panel.	Loosen screws and level instrument.
Bar high after 180° turn.	Aircraft out of trim. Normal, if it does not exceed 1/16 inch.	Trim aircraft.

10-23. REMOVAL AND REPLACEMENT. (Refer to Paragraphs 10-74 and 10-78 of this section.)

10-24. GYRO HORIZON.

10-25. GENERAL. The gyro horizon is essentially an air driven gyroscope rotating in a horizontal plane and is operated by the same principal as the directional gyro. Due to the gyroscopic inertia, the spin axis continues to point in the vertical direction, providing a constant visual reference to the attitude of the airplane relative to pitch and roll axis. A bar across the face of the indicator represents the horizon and aligning the miniature airplane to the horizon bar simulates the alignment of the airplane to the actual horizon. Any deviation simulates the deviation of the airplane from the true horizon. The gyro horizon is marked for different degrees of bank.

10-26. TROUBLESHOOTING.

10-27. REMOVAL AND REPLACEMENT. (Refer to Paragraphs 10-74 and 10-78 of this section.)

10-28. RATE OF CLIMB INDICATOR.

10-29. GENERAL. The rate of climb indicator measures the rate of change in static pressure when the airplane is climbing or descending. By means of a pointer and dial, this instrument will indicate the rate of ascent or descent of the airplane in feet per minute. But due to the lag of the instrument, the aircraft will be climbing or descending before the instrument starts to read and the instrument will continue to read after the aircraft has assumed level flight. In rough air, this should not be considered a malfunction.

CHEROKEE ARROW III SERVICE MANUAL

10-30. TROUBLESHOOTING.

TABLE X-IV. RATE OF CLIMB INDICATOR

Trouble	Cause	Remedy
Pointer does not set on zero.	Aging of diaphragm.	Reset pointer to zero by means of setting screw. Tap instrument while resetting.
Pointer fails to respond.	Obstruction in static line. Pitot head frozen over. Water in static line. Obstruction in pitot head.	Disconnect all instruments connected to the static line. Clear line. Check individual instruments for obstruction in lines. Clean lines and head.
Pointer oscillates.	Leaks in static lines. Defective mechanism.	Disconnect all instruments connected to the static line. Check individual instruments for leaks. Reconnect instruments to static line and test installation for leaks. Replace instrument.
Rate of climb indicates when aircraft is banked.	Water in static line.	Disconnect static lines and blow out lines from cockpit out to pitot head.
Pointer has to be set before every flight.	Temperature compensator inoperative.	Replace instrument.

CHEROKEE ARROW III SERVICE MANUAL

TABLE X-IV. RATE OF CLIMB INDICATOR (cont)

Trouble	Cause	Remedy
Pointer cannot be reset to zero.	Diaphragm distorted.	Replace instrument.
Instrument reads very low during climb or descent.	Case of instrument broken or leaking.	Replace instrument.

NOTE

When any connections in the static system are opened for checking, system must be rechecked per Part 23.1325.

10-31. REMOVAL AND REPLACEMENT. (Refer to Paragraph 10-74 of this section.)

10-32. SENSITIVE ALTIMETER.

10-33. GENERAL. The altimeter indicates pressure altitude in feet above sea level. The indicator has three pointers and dial scale, the long pointer is read in hundreds of feet. the middle pointer in thousands of feet and the short pointer in ten thousands of feet. A barometric pressure window is located on the right side of the indicator dial and is set by the knob located on the lower left corner of the instrument. The altimeter consists of a sealed diaphragm that is connected to the pointers through a mechanical linkage. The instrument case is vented to the static air system and as static air pressure decreases, the diaphragm expands, causing the pointers to move through the mechanical linkage.

10-34. TROUBLESHOOTING.

TABLE X-V. ALTIMETER

Trouble	Cause	Remedy
Excessive scale error.	Improper calibration adjustment.	Replace instrument.
Excessive pointer oscillation.	Defective mechanism.	Replace instrument.

CHEROKEE ARROW III SERVICE MANUAL

TABLE X-V. ALTIMETER (cont)

Trouble	Cause	Remedy
Altimeter sticks at altitude or does not change with change of altitude.	Water or restriction in static line.	Remove static lines from all instruments, blow line clear from cockpit to pitot head.
Altimeter changes reading as aircraft is banked.	Water in static line.	Remove static lines from all instruments, and blow line clear from cockpit to pitot head.
Altimeter requires resetting frequently.	Temperature compensator inoperative.	Change instrument.
High or low reading.	Improper venting.	Eliminate leak in static pressure system and check alignment of airspeed tube.
Setting knob is hard to turn.	Wrong lubrication or lack of lubrication.	Replace instrument.
Inner reference marker fails to move when setting knob is rotated.	Out of engagement.	Replace instrument.
Setting knob set screw loose or missing.	Not tight when altimeter when reset.	Tighten instrument screw, if loose. Replace instrument, if screw is missing.
Cracked or loose cover glass.	Case gasket hardened.	Replace instrument.
Dull or discolored markings.	Age.	

CHEROKEE ARROW III SERVICE MANUAL

TABLE X-V. ALTIMETER (cont)

Trouble	Cause	Remedy
Barometric scale and reference markers out of synchronism.	Slippage mating parts.	Replacement instrument.
Barometric scale and reference markers out of synchronism with pointers.	Drift in mechanism.	Refer to latest revision of AC43.13-1A.

NOTE

When any connections in the static system are opened for check, system must be rechecked per Part 23.1325.

10-35. REMOVAL AND REPLACEMENT. (Refer to Paragraph 10-76 of this section.)

10-36. AIRSPEED INDICATOR.

10-37. GENERAL. The airspeed indicator provides a means of indicating the speed of the airplane passing through the air. The airspeed indication is the differential pressure reading between pitot air to pressure and static air pressure. This instrument has the diaphragm vented to the pitot air source and the case is vented to the static air system. As the airplane increases speed, the pitot air pressure increases, causing the diaphragm to expand. A mechanical linkage picks up this motion and moves the instrument pointer to the indicated speed. The instrument dial is calibrated in knots and miles per hour and also has the necessary operating range markings for safe operation of the airplane.

10-38. TROUBLESHOOTING.

TABLE X-VI. AIRSPEED TUBES AND INDICATOR

Trouble	Cause	Remedy
Pointers of static instruments do not indicate properly.	Leak in instrument case or in pitot lines.	Check for leak and seal.
Pointer of instrument oscillates.	Defective mechanism.	Replace instrument.

CHEROKEE ARROW III SERVICE MANUAL

TABLE X-VI. AIRSPEED TUBES AND INDICATOR (cont)

Trouble	Cause	Remedy
Instrument reads high.	Pointer not on zero.	Replace instrument.
	Leaking static system.	Find leak and correct.
Instrument reads low.	Pointer not on zero.	Replace instrument.
	Leaking static system.	Find leak and correct.
	Pitot head not aligned correctly.	Realign pitot head.
Airspeed changes as aircraft is banked.	Water in pitot line.	Remove lines from static instruments and blow out lines from cockpit to pitot head.

NOTE

When any connections in static system are opened for checking, system must be checked per Part 23.1325.

10-39. REMOVAL AND REPLACEMENT. (Refer to Paragraph 10-76 of this section.)

10-40. MAGNETIC COMPASS.

10-41. GENERAL. The magnetic compass is a self-contained instrument. This instrument has an individual light which is connected to the instrument lighting circuit. The compass correction card is located in the card holder mounted on the instrument. The compass should be swung whenever instruments or radios are changed and at least once a year.

10-41a. ADJUSTMENT OF COMPASS. Before attempting to compensate compass, every effort should be made to place the aircraft in simulated flight conditions; check to see that the doors are closed, flaps in retracted position, engine running, throttle set at cruise position and aircraft in level flight attitude. Aircraft master switch, alternator switch and all radio switches should be in the ON position. All other cockpit controlled electrical switches should be in the OFF position.

- a. Set adjustment screws of compensator on zero. Zero position of adjusting screws is when the dot of the screw is lined up with the dot of the frame.
- b. Head aircraft on a magnetic North heading. Adjust N-S adjustment screw until compass reads exactly North.
- c. Head aircraft on a magnetic East heading and do the same as step b, adjusting E-W adjusting screw.
- d. Head aircraft on a magnetic South heading and note resulting South error. Adjust N-S adjusting screw until one-half of this error has been removed.

CHEROKEE ARROW III SERVICE MANUAL

- e. Head aircraft on magnetic West and do same as step d, adjusting E-W adjusting screw.
- f. Head aircraft in successive magnetic 30° headings and record compass readings on appropriate deviation card. Deviations must not exceed $\pm 10^\circ$ on any heading.

10-42. TROUBLESHOOTING.

TABLE X-VII. MAGNETIC COMPASS

Trouble	Cause	Remedy
Excessive card error.	Compass not properly compensated.	Compensate instrument. (Refer to Paragraph 10-41a.)
	External magnetic interference.	Locate magnetic interference and eliminate if possible.
Excessive card oscillation.	Insufficient liquid.	Replace instrument.
Card sluggish.	Wear card magnet.	Replace instrument.
	Excessive pivot friction or broken jewel.	Replace instrument.
Liquid leakage.	Loose bezel screws.	Replace instrument.
	Broken cover glass.	Replace instrument.
	Defective sealing gaskets.	Replace instrument.
Discolored markings.	Age.	Replace instrument.
Defective light.	Burned out lamp or broken circuit.	Check lamp or continuity or wiring.
Card sticks.	Altitude compensating diaphragm collapsed.	Replace instrument.
Card does not move when compensating screws are turned.	The gears that turn compensating magnets are stripped.	Replace instrument.

CHEROKEE ARROW III SERVICE MANUAL

TABLE X-VII. MAGNETIC COMPASS (cont)

Trouble	Cause	Remedy
Compass swings erratically when radio transmitter is keyed.	Normal.	

10-43. MANIFOLD PRESSURE GAUGE.

10-44. GENERAL. The manifold pressure gauge is a vapor proof, absolute pressure type instrument. Pressure from the intake manifold of the engine is transmitted to the instrument through a line. A pointer indicates the manifold pressure available at the engine in inches of mercury.

10-45. TROUBLESHOOTING.

TABLE X-VIII. MANIFOLD PRESSURE INDICATOR

Trouble	Cause	Remedy
Excessive error at existing barometric pressure.	Pointer shifted.	Replace instrument.
Excessive error when engine is running.	Line leaking.	Tighten line connections.
Sluggish or jerky pointer movement.	Defective instrument.	Replace instrument.
Dull or discolored marking.	Age.	Replace instrument.
Incorrect reading.	Moisture or oil in line.	Disconnect lines and blow out.

10-46. REMOVAL AND REPLACEMENT. (Refer to Paragraph 10-76 of this section.)

CHEROKEE ARROW III SERVICE MANUAL

10-47. TACHOMETER INDICATOR.

10-48. GENERAL. The tachometer is connected to the engine accessory by a flexible cable and provides an indication of crankshaft speed in revolutions per minute. The instrument has a recording mechanism for recording the time that the engine is in actual operation.

10-49. TROUBLESHOOTING.

TABLE X-IX. TACHOMETER

Trouble	Cause	Remedy
No reading on indicator either permanent or intermittent.	Broken shaft	Replace instrument.
	Loose cable connections.	Tighten cable.
Pointer oscillates excessively.	Rough spot on, or sharp bend in shaft.	Repair or replace.
	Excessive friction in instrument.	Replace instrument.
Indicator changes in climb.	Excessive clearance in speed cup.	Replace instrument.
pointer goes all the way to stop, more noticeable in cold weather.	Excessive lubricant in instruments.	Replace instruments.
Pointer jumps at idle.	Speed cup hitting rotating magnet.	Replace instrument.
Tachometer cable breaks.	Cable bent too sharply.	Reroute cable.

10-50. REMOVAL AND REPLACEMENT. (Refer to Paragraph 10-76 of this section.)

CHEROKEE ARROW III SERVICE MANUAL

10-51. ENGINE OIL PRESSURE GAUGE.

10-52. GENERAL. The oil pressure gauge is mounted in the cluster on the instrument panel. This gauge will indicate the amount available at the pressurized engine oil passage.

10-53. TROUBLE SHOOTING.

TABLE X-X. ENGINE OIL PRESSURE GAUGE

Trouble	Cause	Remedy
Excessive error at zero.	Pointer loose on shaft. Overpressure or seasoning of bourdon tube.	Replace instrument.
Excessive scale error.	Improper calibration adjustment.	Replace instrument.
Excessive pointer oscillation.	Air in line or rough engine relief.	Disconnect line and fill with light oil. Check for leaks. If trouble persists, clean and adjust relief valve.
Sluggish operation of pointer or pressure fails to build up.	Engine relief valve open.	Clean and check.

10-54. REMOVAL AND REPLACEMENT. (Refer to Paragraph 10-78 of this section.)

10-55. FUEL PRESSURE GAUGE.

10-56. GENERAL. The fuel pressure gauge instrument is mounted in the cluster on the instrument panel. This gauge is connected to the fuel system at the carburetor fuel inlet fitting.

CHEROKEE ARROW III SERVICE MANUAL

10-57. TROUBLESHOOTING.

TABLE X-XI. FUEL PRESSURE GAUGE

Trouble	Cause	Remedy
No fuel pressure indication.	Fuel valve stuck. No fuel in tanks. Defective fuel pump. Defective gauge.	Check valve. Check fuel, full. Check pump for pressure buildup. Check diaphragm and relief valve in engine pump. Check for obstruction in electric pump. Check bypass valve. Air leak in intake lines. Replace gauge.
Pressure low or pressure surges.	Obstruction in inlet side of pump. Faulty bypass valve. Faulty diaphragm.	Trace lines and locate obstruction. Replace. Replace or rebuild pump.
Needle fluctuation.	Purge dome or pump filled with fuel. Air in line.	Remove and empty. Loosen line at gauge, turn on electric pump. Purge line of air and retighten.
High fuel pressure with engine shut off right after flight.	Fuel in line expanding due to heat build up in cowling.	Normal.

10-58. REMOVAL AND REPLACEMENT. (Refer to Paragraph 10-78 of this section.)

CHEROKEE ARROW III SERVICE MANUAL

10-59. ELECTRICAL INSTRUMENTS.

10-60. TURN AND BANK INDICATOR.

10-61. GENERAL. The turn and bank indicator is an electrical instrument. The turn portion of the indicator is driven by a permanent magnet DC governor controlled gyro motor. Damping action is provided by a precision air dashpot. The indicator is designed to indicate the rate of turn and roll; which means, if the aircraft is rolled right and left rapidly, the indicator will move, indicating a turn, but if the aircraft is held in a bank, by applying rudder, the indicator will come back to zero indicating no turn. The bank portion of the indicator is a ball sealed in a curved glass tube filled with damping fluid. In an improperly coordinated turn, the ball is forced from the center of the tube, thus indicating attitude error.

10-62. TROUBLESHOOTING.

TABLE X-XII. TURN AND BANK INDICATOR

Trouble	Cause	Remedy
Pointer fails to respond.	Foreign matter lodged in instrument.	Replace instrument.
Incorrect sensitivity.	Out of calibration.	Replace instrument.
Incorrect turn rate.	Out of calibration. Aircraft not in coordinated turn	Replace instrument. Center ball in turn.
Instrument will not run.	No Dower to instrument. Instrument malfunction.	Check circuit and repair. Replace instrument.

10-63. REMOVAL AND REPLACEMENT. (Refer to Paragraph 10-76 of this section.)

10-64. FUEL QUANTITY INDICATOR.

10-65. GENERAL. The two quantity gauges are mounted in the cluster on the instrument panel. These instruments are calibrated in divisions of 10, 20, 30 gallons and full. Two transmitter units are installed in each fuel cell. These units contain a resistance strip and a movable control arm. The position of this arm is controlled by a float in the fuel cell and this position is transmitted electrically to the indicator gauge to show the amount of fuel in the cell.

CHEROKEE ARROW III SERVICE MANUAL

10-66. TROUBLESHOOTING.

TABLE X-XIII. FUEL QUANTITY INDICATORS

Trouble	Cause	Remedy
Fuel gauge fails to indicate.	Broken wiring.	Check and repair
	Gauge not operating.	Replace.
Fuel gauge indicates empty when tanks are full.	Incomplete ground.	Check ground connections at fuel transmitter in wings.
Fuel gauge indicates full with tanks empty.	Incomplete ground.	Check ground at instrument.
	Float arm stuck.	Replace fuel transmitter.
Fuel gauge indicated incorrectly.	Intermittent electrical connection.	Check ground at grounded transmitter and electrical connections.
	Float arm sticky.	Replace fuel transmitter.
	Insulated transmitter grounded.	Remove transmitter and sealant. Check for metal particles in sealant. Reseal to prevent ground.

10-67. REMOVAL AND REPLACEMENT. (Refer to Paragraph 10-78 of this section.)

10-68. OIL TEMPERATURE INDICATOR.

10-69. GENERAL. The oil temperature indicator is mounted in the instrument cluster on the instrument panel. This instrument will provide a temperature indication of the engine oil in degrees Fahrenheit. The instrument has a temperature bulb located in the oil screen assembly on engines with screens, and on the top of the oil cooler mounting flange on engines with an oil filter, located on the engine accessory section.

CHEROKEE ARROW III SERVICE MANUAL

10-70. TROUBLESHOOTING.

TABLE X-XIV. OIL TEMPERATURE INDICATORS

Trouble	Cause	Remedy
Instrument fails to show any reading.	Broken or damaged bulb. Wiring open.	Check engine unit and wiring to instrument.
Excessive scale error.	Improper calibration adjustment.	Repair or replace.
Pointer fails to move as engine is warmed up.	Broken or damaged bulb or open wiring.	Check engine unit and wiring.
Dull or discolored marking.	Age.	Replace instrument.

10-71. REMOVAL AND REPLACEMENT. (Refer to Paragraph 10-78 of this section.)

10-72. AMMETER.

10-73. GENERAL. The ammeter is mounted in the instrument panel. This instrument measures the output of the alternator into the entire electrical system including the battery charging demand.

10-74. TROUBLESHOOTING. (Refer to Section XI, Alternator Section.)

10-75. REMOVAL AND REPLACEMENT. (Refer to Paragraph 10-76 of this section.)

10-76. REMOVAL AND REPLACEMENT OF FACE MOUNTED INSTRUMENTS.

10-77. GENERAL. Since all instruments are mounted in a similar manner, a description of a typical removal and installation is provided as a guide for the removal and installation of the instruments. Special care should be taken when any operation pertaining to the instruments is performed.

- a. Remove the face panel by removing the screws from around the perimeter of the panel.
- b. With the face panel removed, the mounting screws for the individual instruments will be exposed. Remove the connections to the instrument prior to removing the mounting screws of the instrument to be removed.

NOTE

Tag instrument connections for ease of installation.

- c. Installation of the instruments will be in the reverse given for removal. After the installation is completed and before replacing the instrument face panel, check all components for security and clearance of the control column.

CHEROKEE ARROW III SERVICE MANUAL

10-78. REMOVAL AND REPLACEMENT OF CLUSTER MOUNTED INSTRUMENTS.

10-79. GENERAL. A cluster, located on the instrument panel, contains five individual instruments. Removal of these instruments can be accomplished by the following procedure:

- a. Remove the face panel by pulling from retaining channels at top and bottom.
- b. With the face panel removed, the clear plastic cover on the cluster assembly will be exposed. Remove the cover and cluster by removing the two mounting screws.
- c. Remove the connection to the individual instrument to be removed and remove the instrument from the cluster assembly.
- d. Replace instrument in the reverse order of removal. Check all mountings and connections for security.

10-80. GYRO FITTING INSTALLATION PROCEDURE. The following procedure applies to those aircraft having the Edo-Aire air driven gyro installation. The use of teflon tape on fitting threads is recommended.

CAUTION

Permit no oil, grease, pipe compound or any foreign material to enter ports prior to installation of fittings. Make certain all air lines are clean and free of foreign particles and/or residue before connecting lines to gyro.

NOTE

Use of thread lube on fittings or in ports will create a warranty void condition.

- a. Carefully lay teflon tape on the threads allowing one thread to be visible from the end of the fitting. Hold in place and wrap in the direction of the threads so tape will remain tight when fitting is installed.
- b. Apply sufficient tension while winding to assure that tape forms into thread grooves. One full wrap plus 1/2 inch overlap is sufficient.
- c. After wrap is completed, maintain tension and tear tape by pulling in direction of wrap. The resulting ragged end is the key to the tape staying in place.
- d. Press the tape well into the threads.
- e. Screw fitting into port being careful not to exceed torque requirements as noted on decal on gyro cover.

10-81. CYLINDER HEAD TEMPERATURE GAUGE.

10-82. GENERAL. The cylinder head temperature gauge is in the instrument cluster, located on the instrument panel. This instrument measures the cylinder head temperature using a sender located in a cylinder head. The head location is determined by the manufacturer. It is an electrical instrument and is wired thru the instruments circuit breaker.

CHEROKEE ARROW III SERVICE MANUAL

10-83. TROUBLESHOOTING.

TABLE X-XV. CYLINDER HEAD TEMPERATURE GAUGE

Trouble	Cause	Remedy
Instrument shows no indication.	Power supply wire broken.	Repair wire.
	Defective instrument.	Replace instrument.
	Master switch off	
Instrument goes all the way to upper stop.	Wire broken between sender and gauge.	Repair wire.
	Defective sender.	Replace sender.

10-84. REMOVAL AND REPLACEMENT. (Refer to Paragraph 10-78 of this section.)

10-85. PIPER AUTOCONTROL SYSTEM. (See AutoControl Service Manual.)

10-86. ANNUNCIATOR PANEL.

10-87. GENERAL. The annunciator panel for both the PA-28R-201 and the PA-28R-201T consists of three amber lights and a push-button test switch located on the upper left center portion of the instrument panel. Two additional amber lights come with the PA-28R-201T model. (Refer to Figure 10-1.) The panel monitors alternator output, oil pressure and the vacuum system. The ALT warning light will illuminate when alternator output is zero; the VAC light when the pressure difference is below 3.5 in. Hg; OIL light when the oil pressure is below 35 psi on PA-28R-201 or 30 psi on PA-28R-201T and the over BST light (PA-28R-201T only) when the engine manifold pressure exceeds $40.75 + .15$ in. Hg. A smaller light (PA-28R-201T only) indicates when the auxiliary fuel pump is on. A test Button is included to check the operation of all the lights except for the auxiliary fuel pump light. Refer to Section XI for service information.

10-88. TROUBLESHOOTING. (Refer to Table XI-I.)

10-89. REMOVAL AND REPLACEMENT. (Refer to Paragraph 10-76.)

SECTION XI

ELECTRICAL SYSTEM

Paragraph	Aerofiche Grid No.
11-1. Introduction	2G18
11-2. Description	2G18
11-3. Troubleshooting.....	2G18
11-4. Alternator System.....	2G18
11-5. Alternator System (Chrysler)	2G20
11-6. Alternator System Test Procedure.....	2G20
11-7. Bench Testing Alternator.....	2G20
11-8. Field Current Draw.....	2G20
11-9. Testing Alternator Internal Field Circuit for a Ground.....	2G21
11-10. Inspection	2G21
11-11. Testing Rectifiers (Positive)	2G22
11-12. Testing Rectifiers (Negative).....	2G23
11-13. Removing and Installing Rectifiers.....	2G24
11-14. Removing Rectifiers.....	2H1
11-15. Installing Rectifiers	2H1
11-16. Testing Stator Coils for Ground.....	2H3
11-17. Testing Alternator Capacitors.....	2H3
11-18. Removing Needle Bearing from End Shield.....	2H4
11-19. Installing Needle Bearing in End Shield.....	2H4
11-20. Removing Drive Pulley.....	2H5
11-21. Removing Drive End Bearing.....	2H5
11-22. Replacing Slip Rings.....	2H5
11-23. Removing Slip Rings.....	2H6
11-24. Installation of Slip Rings.....	2H6
11-25. Installing Grease Retainer	2H7
11-26. Installing Drive End Bearing.....	2H7
11-27. Installing Pulley.....	2H8
11-28. Assembling End Shield Sub-Assemblies	2H8
11-29. Bench Run-Up Test	2H9
11-30. Bench Hot Stabilization Output Test.....	2H9
11-31. Checking Alternator Belt Tension.....	2H10
11-32. Alternator System (Prestolite).....	2H11
11-33. Alternator Nomenclature.....	2H11
11-34. Alternator Precautions.....	2H11
11-35. Description of Alternator.....	2H12
11-36. Overhaul of Alternator	2H13
11-37. Disassembly of Alternator.....	2H13
11-38. Inspection and Testing of Components	2H14

Paragraph	Aerofiche Grid No.
11-39. Assembly of Alternator	2H15
11-40. Testing of Alternator.....	2H17
11-41. Alternator Service Test Specifications	2H17
11-42. Checking Alternator Belt Tension (PA-28R-201 only).....	2H19
11-43. Voltage Regulator (Wico).....	2H19
11-44. Checking Voltage Regulator.....	2H19
11-45. Overvoltage Relay (Wico).....	2H20
11-46. Checking Overvoltage Relay.....	2H20
11-47. Starting Motors (Prestolite).....	2H20
11-48. Description	2H20
11-49. Operation.....	2H20
11-50. Maintenance	2H21
11-51. Overhaul.....	2H22
11-52. Removal.....	2H22
11-53. Disassembly.....	2H23
11-54. Brushes.....	2H24
11-55. Armature.....	2H24
11-56. Field Coils	2H24
11-57. Brush Holders.....	2H24
11-58. Gear and Pinion Housing (PA-28R-201).....	2I1
11-59. Bendix Drive (PA-28R-201).....	2I1
11-60. Assembly.....	2I1
11-61. Bench Tests.....	2I2
11-62. Starting Motor Control Circuit.....	2I2
11-63. Starting Motor Service Test Specification.....	2I2
11-64. Battery	2I2
11-65. Servicing Battery.....	2I2
11-66. Removal of Battery.....	2I2
11-67. Installation of Battery.....	2I3
11-68. Charging Battery.....	2I3
11-69. Battery Box Corrosion Prevention	2I4
11-70. Starting Through External Power Receptacle with Airplane's Battery Nearly Depleted	2I4
11-71. Landing and Taxi Light	2I5
11-72. Description	2I5
11-73. Removal.....	2I5
11-74. Installation.....	2I5
11-75. Navigation Lights.....	2I5
11-76. Description	2I5
11-77. Removal of Wing Navigation Lights.....	2I5
11-78. Installation of Wing Navigation Lights.....	2I5

Paragraph	Aerofiche Grid No.
11-79. Removal of Tail Navigation Light.....	2I6
11-80. Installation of Tail Navigation Light.....	2I6
11-81. Anti-Collision (Strobe).....	2I6
11-82. Description	2I6
11-83. Removal of Wing Tip Strobe Light.....	2I6
11-84. Installation of Wing Tip Strobe Light.....	2I6
11-85. Removal of Strobe Power Supply	2I6
11-86. Installation of Strobe Power Supply.....	2I6
11-87. Troubleshooting Procedure.....	2I9
11-88. Instrument and Panel Lights.....	2I10
11-89. Removal of Dimmer Control Assembly.....	2I10
11-90. Installation of Dimmer Control Assembly.....	2I10
11-91. Annunciator Panel.....	2I10
11-92. Description	2I10
11-93. Removal of Oil Pressure Sensor.....	2I10
11-94. Installation of Oil Pressure Sensor.....	2I11
11-95. Removal of Vacuum Sensor	2I11
11-96. Installation of Vacuum Sensor.....	2I11
11-97. Ignition Switch	2I11
11-98. Removal of Ignition Switch.....	2I11
11-99. Installation of Ignition Switch.....	2I11

CHEROKEE ARROW III SERVICE MANUAL

SECTION XI

ELECTRICAL SYSTEM

WARNING

When servicing or inspecting vendor equipment installed in Piper aircraft, it is the user's responsibility to refer to the applicable vendor publication.

11-1. Introduction. This section contains instructions and schematics for correcting difficulties which may arise in the operation of the electrical system in PA-28R-201 and PA-28R-201T airplanes.

The instructions are organized so the mechanic can refer to: Description and Principles of Operation for a basic understanding of the various electrical system; Troubleshooting for a methodical approach in locating the difficulty; Corrective Maintenance of removal, repair and installation of components; and adjustments and tests for operation of the repaired system. Schematics for the individual systems are located at the end of this section. For information concerning electronic equipment, refer to Section XII, Electronics.

11-2. DESCRIPTION. Electrical power is supplied by a 14 volt, direct current, negative ground electrical system. A 12 volt battery is incorporated into the system to furnish power for starting and as a reserve power source in case of alternator failure. Access to the battery is through the aft side of the baggage compartment.

The electrical generating system consists of an engine driven 60 amp alternator for the PA-28R-201 or a 65 amp alternator for the PA-28R-201T. A solid state voltage regulator maintains the system bus voltage at 14 volts. Also incorporated is an overvoltage relay, which prevents damage to electrical and avionics equipment in case of a regulator malfunction. The loads from the electrical bus systems are protected by manual reset type circuit breakers mounted on the lower right hand side of the instrument panel.

The master switch must be ON before any electrical equipment will operate. The master switch controls the battery relay and field circuit. This switch is a double pole single throw type.

The lighting system for night time operation is optional equipment and consists of a landing light, anticollision lights and navigation lights.

11-3. TROUBLESHOOTING. Troubles peculiar to the electrical system are listed in Table XI-V at the back of this section along with their probable causes and suggested remedies. The wiring diagrams included at the end of this section will give physical breakdown of the different electrical circuits used in these airplanes.

After the trouble has been corrected, check the entire system for security and operation of its components.

WARNING

All checks and adjustments of the alternator and/or its components should be made with the engine stopped. Therefore, to complete some checks or adjustments, it will be necessary to remove these units from the airplane and place on a test stand.

11-4. ALTERNATOR SYSTEM. The PA-28R-201 alternator is located on the front lower right side of the engine and utilizes a belt drive from the engine crankshaft. The PA-28R-201T alternator is mounted on the accessory case at the rear of the engine. Many advantages, both in operation and maintenance, are derived from this system. The main advantage is that full electrical power output is available regardless of engine rpm.

CHEROKEE ARROW III SERVICE MANUAL

The alternator has no armature or commutator and only a small pair of carbon brushes, which make contact with a pair of copper slip rings. The rotating member of the alternator, known as the rotor, is actually the field windings. The rotor draws only 1/20th of the current output. Therefore, there is very little friction and negligible wear and heat in this area. The alternating current is converted to direct current by diodes pressed into the end bell housing of the alternator. The diodes are highly reliable solid state devices, but are easily damaged if current flow is reversed through them.

The alternator system does not require a reverse current relay, because of the high back resistance of the diodes and the inability of the alternator to draw current or motorize. A current regulator is unnecessary because the windings have been designed to limit the maximum current available. Therefore, the voltage regulator is the only control needed.

An additional latching circuit is used to help keep the master solenoid closed when the battery voltage is low and the engine starter is being operated. This circuit transfers voltage from the alternator to the master solenoid coil, thus holding the master solenoid in the closed position and allowing the starter to function. This circuit will also supply some voltage to the battery. A diode is placed into this circuit to prevent the reverse flow of current from the battery to the alternator.

The circuit breaker panel contains a 5-ampere circuit breaker marked ALT FIELD. If the field circuit breaker trips it will result in a complete shutdown of power from the generating system. After a one or two minute cool-down period, the breaker can be reset manually. If tripping recurs and holding the breaker down will not prevent continual tripping, then a short exists in the alternator field.

Unlike previous systems, the ammeter does not indicate battery discharge, but displays the load in amperes placed on the generating system. With all electrical equipment off, except the master switch, the ammeter will indicate the amount of charging current demanded by the battery. This amount will vary, depending on the percentage of charge in the battery at the time. As the battery becomes charged, the amount of current displayed on the ammeter will reduce to approximately two amperes. The amount of current shown on the ammeter will tell immediately whether or not the alternator system is operating normally, if the following principles are kept in mind.

NOTE

The amount of current shown on the ammeter is the load in amperes that is demanded by the electrical system from the alternator. As a check, take for example a condition where the battery is demanding 10-amperes charging current, then switch on the landing light. Note the value in amperes placarded on the panel for the landing light fuse (10 amps) and multiply this by 80 percent, you will arrive at a current of 8-amperes. This is the approximate current drawn by the light. Therefore, when the light is switched on, there will be an increase of current from 10 to 18-amperes displayed on the ammeter. As each unit of electrical equipment is switch on, the currents will add up and the total, including the battery, will appear on the ammeter.

CHEROKEE ARROW III SERVICE MANUAL

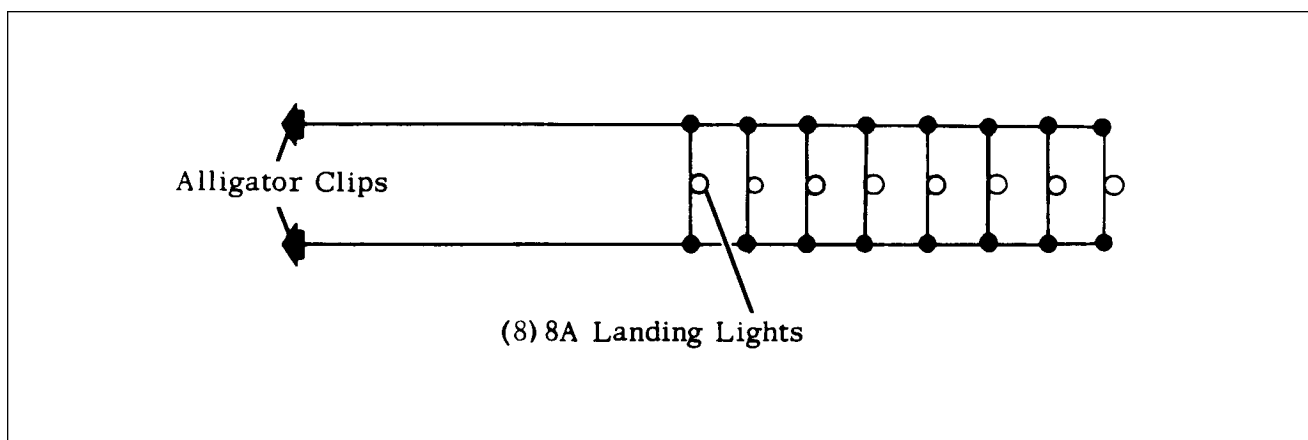

Figure 11-2. Lamp-Bank Load

11-5. ALTERNATOR SYSTEM (Chrysler).

WARNING

When servicing or inspecting vendor equipment installed in Piper aircraft, it is the user's responsibility to refer to the applicable vendor publication.

11-6. ALTERNATOR SYSTEM TEST PROCEDURE.

- a. Start engine and set throttle for 1000 to 1200 rpm.
- b. Switch on the following loads and observe the ammeter output increase as indicated:
 1. Rotating beacon - 3 to 6 amps.
 2. Navigation and instrument lights (bright position) - 4 to 6 amps.
 3. Landing light - 7 to 9 amps.
 4. VHF radio - 4 to 6 amps each. If alternator does not meet above indications, refer to Troubleshooting Chart. (Follow troubleshooting procedure outlined on chart in a step-by-step fashion checking each cause and isolation procedure under a given trouble before proceeding with the following cause and isolation procedure.)

On airplanes without night flying equipment, load required by test can be simulated by connecting a lamp bank load consisting of 8 landing lights wired in parallel from main bus (+) to airframe ground (-) (refer to Figure 11-2) or 14, 3-ohm, 100-watt resistors.

11-7. BENCH TESTING ALTERNATOR.

11-8. FIELD CURRENT DRAW. Connect a test ammeter in series between a 12-volt battery positive post and the alternator field terminal. (Refer to Figure 11-3.) Connect a jumper wire to a machined surface on one of the alternator end shields (ground) and to the negative battery post. The reason for connecting to the machined surface is to ensure a good electrical connection. The end shields are treated to oppose corrosion. The material used to treat the end shields is not a good electrical conductor.

Observe the ammeter to determine the current flowing through the rotor coil and connected circuit and record the amount. Slowly rotate the rotor with the pulley while watching the meter. The current will be a little less while rotating the rotor than when stationary. However, if the slip rings are clean and the brushes are making good contact, the reading should be fairly even. A slight fluctuation will be normal due to variation in turning speed when operated by hand.

The current draw should not be less than 2.3-amperes nor more than 2.7-amperes. A reading of less than 2.3-amperes indicated high resistance due to poorly soldered coil leads at the slip rings, dirty, oily slip rings or poor brush contact. A reading higher than 2.7-amperes indicates shorted coil windings.

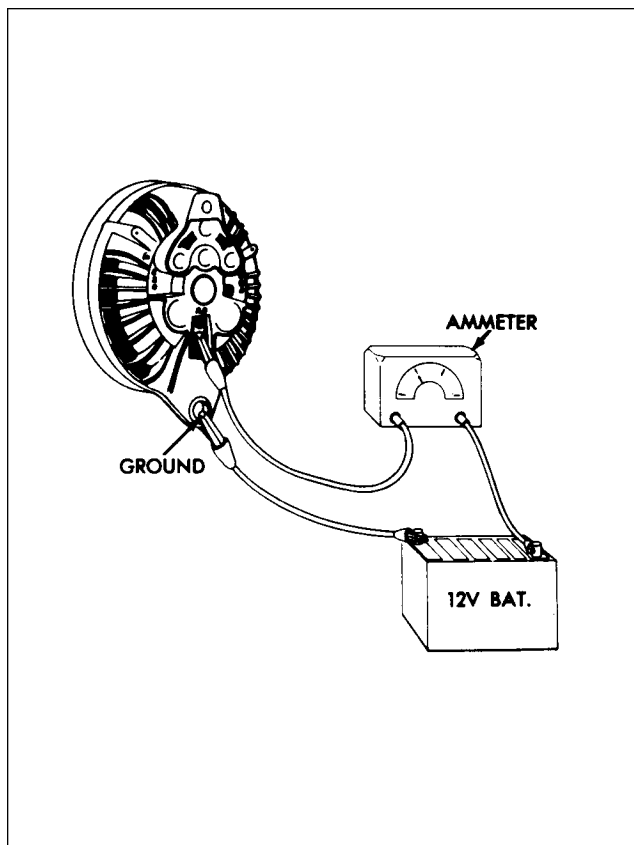
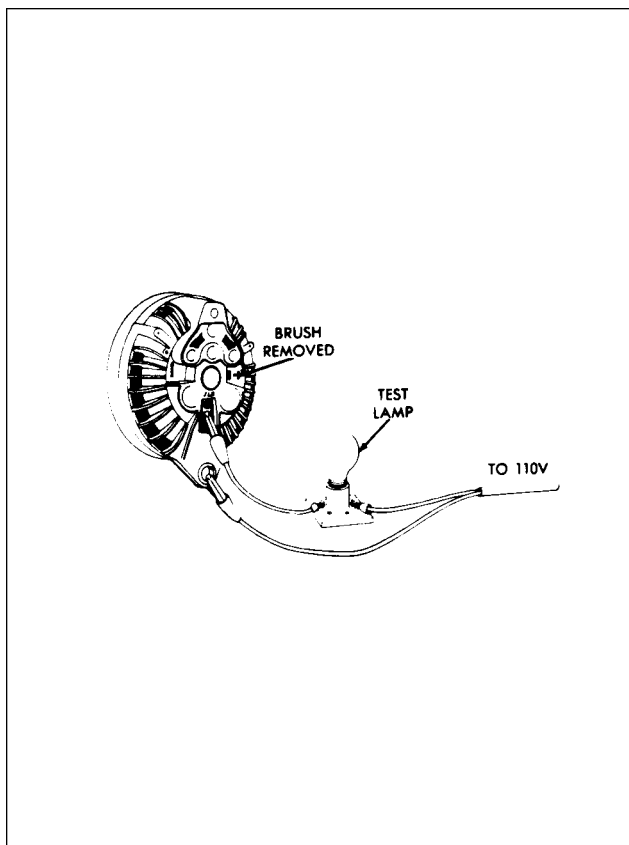

Figure 11-3. Checking Field



Circuit Figure 11-4. Testing Field Circuit

11-9. TESTING ALTERNATOR INTERNAL FIELD CIRCUIT FOR A GROUND. To test the alternator internal field circuit for a short circuit foreground, proceed as follows:

- a. Remove the ground brush and using a 110-volt test lamp, place one test probe to the field terminal and the remaining test probe to a machined surface at one of the alternator end shields. (Refer to Figure 11-4.) The test lamp should not light.

If the test lamp lights, carefully observe the order in which the parts were installed as you remove the insulated brush assembly. Remove the three through bolts. Then, separate the two end shield assemblies. Touch one of the test lamp probes to one of the slip rings and the remaining test probe to the rotor shaft. The lamp should not light. If the lamp lights, the rotor assembly is grounded and requires replacement.

If the test lamp does not light, the ground condition was in the insulated brush assembly and the parts were either assembled wrong or damaged and short circuiting through to ground. Inspect the brush holder and insulated washer. Replace if damaged. The stack of parts attaching the insulated brush holder assembly to the end shield must always be installed in the proper sequence as follows: Insulated brush holder, "FLD" terminal, insulating washer, lockwasher and attaching screw.

11-10. INSPECTION. Inspect the condition of the alternator components paying special attention to the condition of the slip rings for indications of oil, being burnt or worn. Inspect brushes for signs of sticking in holder or shield and for wear.

Inspect the bearing surface of the rotor shaft and the roller bearings at the rectifier end. Rotate the rotor in the drive end shield to feel roughness in the drive end bearing. Inspect the grease retainer. Inspect the rectifier leads especially at connections for a good solder joint, also inspect insulation. Rectifier/stator lead must be pushed down into the slots that are cast into the end shield and cemented with MoPar Cement #2299314.

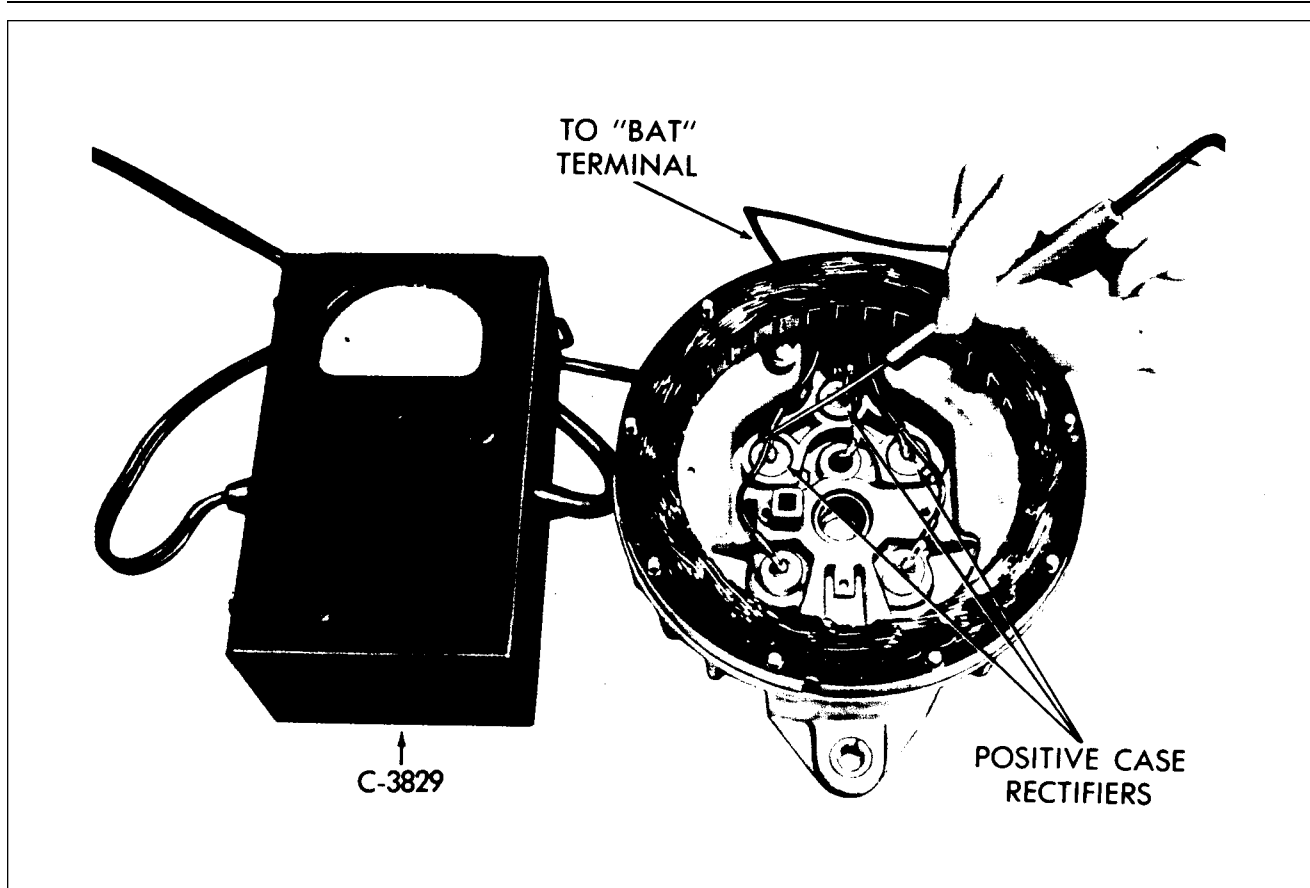

Figure 11-5. Testing Rectifiers (Positive)

11-11. TESTING RECTIFIERS (POSITIVE). (Refer to Figure 11-5.) Special test box tool C-3829 has been developed to test the diode rectifiers without opening the “Y” connection as is necessary where the test lamp method is used.

Due to the short leads at the “Y” connection, it is quite difficult to separate and reconnect them properly. This tool, C-3829, will save much time and is accurate.

Insulate alternator from metal bench and plug tester tool C-3829 into a 110-volt supply. Connect the alligator clip of tool C-3829 to the alternator “BAT” terminal and touch the bare metal of each of the positive case rectifier lead wires in the heat sink at the rectifiers.

The meter reading for each of the rectifiers should be the same. Always contact the connection nearest the rectifiers.

Do not break the sealing on the rectifier lead wire or on the top of the rectifiers. The sealing material is used for corrosion protection.

The reading on the meter will indicate 1.7 or over for good rectifiers. Where two of the rectifiers are good and one is shorted, the reading taken at the good rectifiers will show low. The reading at the shorted rectifier will be zero. Cut the lead at the bad rectifier and the reading at the two good rectifiers will come up to normal. Where one of the rectifiers is open, it will read low (1 amp or less) the two good rectifiers will show normal.

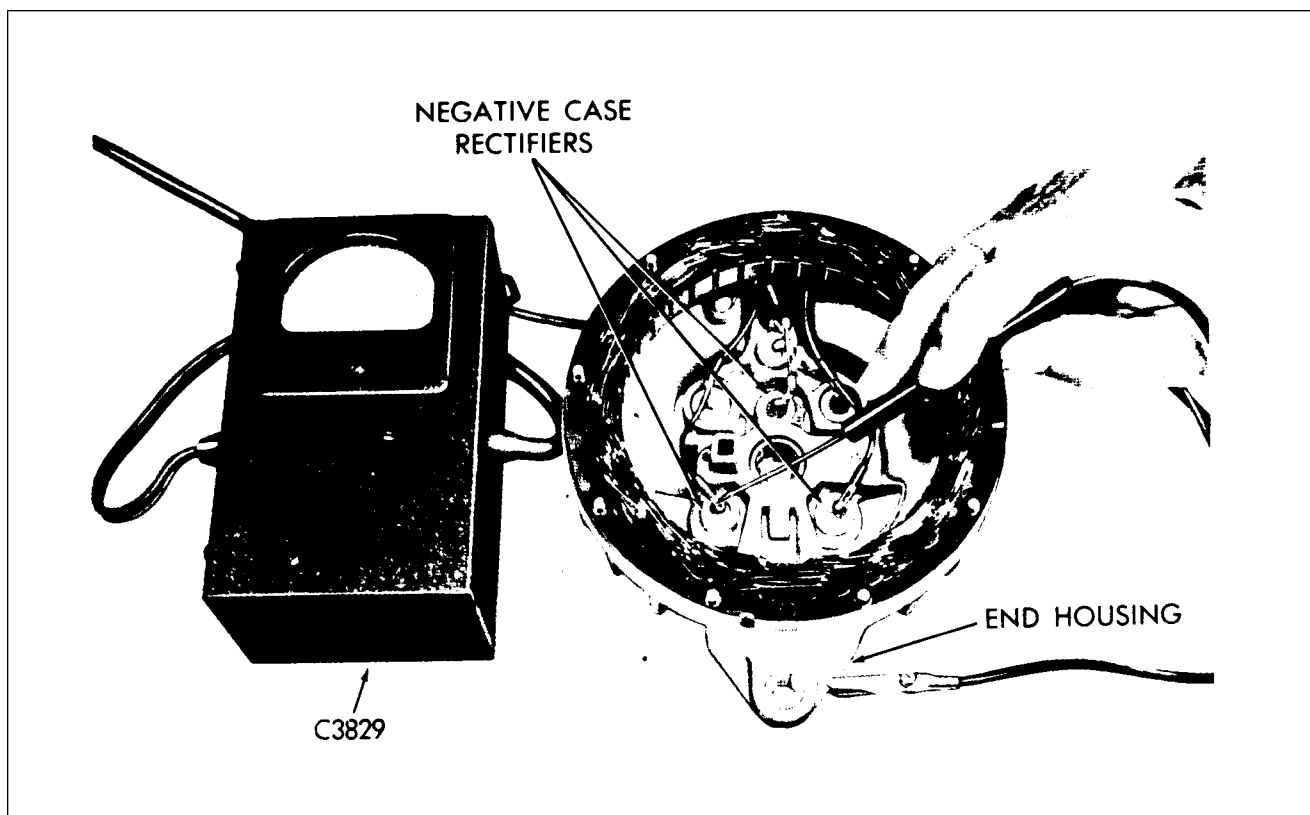

Figure 11-6. Testing Rectifiers (Negative)

NOTE

Any tools called out by a "C" or "SP" number in this section may be purchased from:

Miller Special Tools
 A Division of Utica Tool Company, Inc.
 32612 Park Lane
 Garden City, Michigan 48135 Phone: (313) 522-6717

11-12. TESTING RECTIFIERS (NEGATIVE). To test the negative case rectifiers in the end shield, connect the alligator clip of tool C-3829 to the end shield.

Touch the test prod to the bare wire of the rectifier leads at the rectifiers in the end shield. The meter will indicate the condition of the rectifier.

The test indications are the same for the negative case rectifiers in the end shield as they are for the positive case rectifiers in the heat sink. However, the meter will read at the opposite end of the scale.

NOTE

If all three of the negative rectifiers read low, before condemning the rectifiers, test for a grounded stator. A grounded stator will cause the negative rectifiers (in the end shield) to read low.

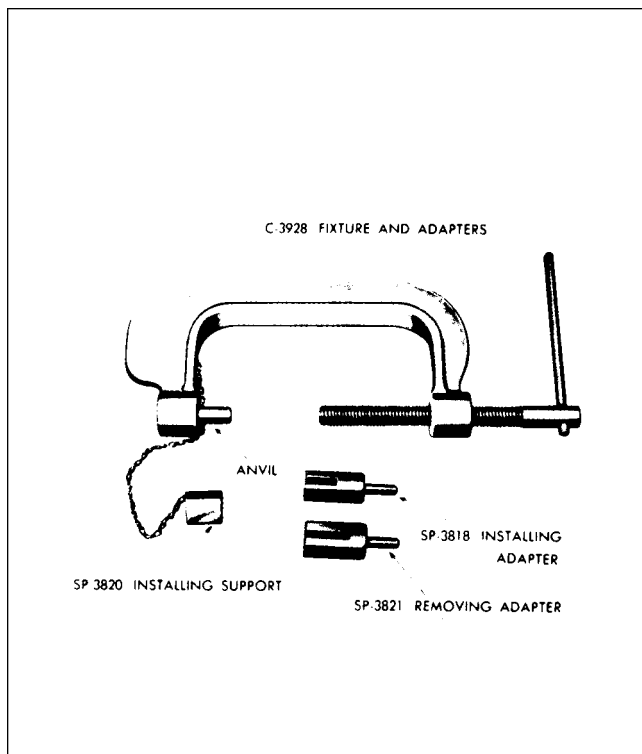

Figure 11-7. C-3928 Fixture and Adapters

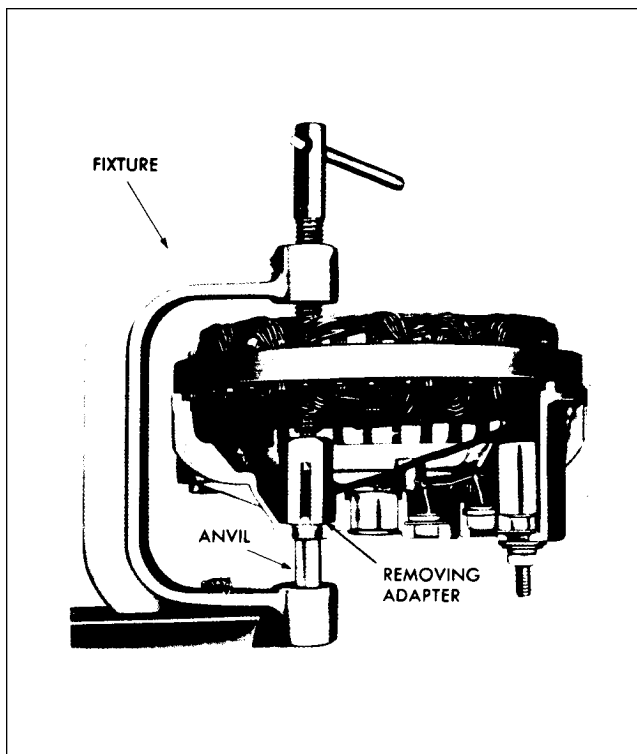

Figure 11-8. Removing Rectifiers

NOTE

A common cause of an open or a shorted rectifier is a defective capacitor or a battery that has been installed in reverse polarity. If the battery is installed properly and the rectifiers are open, test the capacitor with a condenser tester.

11-13. REMOVING AND INSTALLING RECTIFIERS. The use of proper tools for the removal and installation of rectifiers cannot be over emphasized. A special tool kit has been developed to remove and replace new rectifiers without damage.

NOTE

Only new rectifiers should be installed. It is not recommended to reinstall rectifiers once they have been removed.

The tool kit can be used on all Chrysler built alternators. A press is not required when using the C-3928 tool kit for removing or installing rectifiers. Three diode rectifiers are pressed into the heat sink and three in the end shields.

The new tool consists of a clamp type fixture with special adapters. This tool makes it unnecessary to use a press.

The tool assembly consists of the following components:

- C-3928 - Fixture and Adapters
- SP-3821 - Removing Adapter
- SP-3818 - Installing Adapter
- SP-3820 - Installing Support

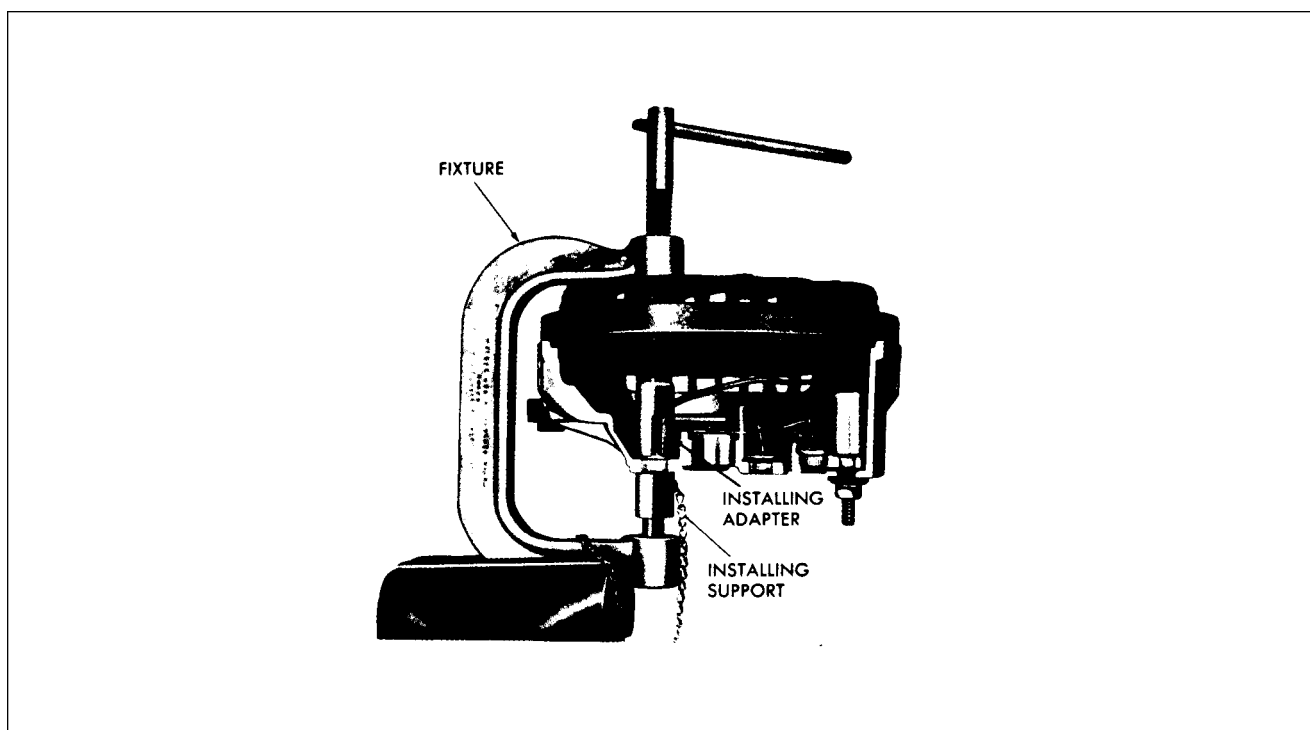

Figure 11-9. Installing Rectifiers

11-14. REMOVING RECTIFIERS. After cutting the lead from the malfunctioning rectifier, position the fixture with the rectifier to be removed over the fixture anvil.

Position the removing adapter SP-3821 around the rectifier. Rotate the threaded screw clockwise. As the screw approaches the removing adapter, guide its shank into the hole in the end of the screw.

Just before the downward motion of the screw bottoms, recheck the adapter to be sure it is in the proper position. Then continue to rotate the screw until the rectifier is free of the end shield or heat sink.

Reverse the screw by rotating it counterclockwise. Remove adapter and old rectifier.

Remove the end shield assembly from the fixture and position SP-3820 installing support on the fixture anvil.

11-15. INSTALLING RECTIFIERS. Start the new rectifier as squarely as possible into the hole the old rectifier was removed from after first checking to be sure it is of the proper polarity. The negative rectifiers are marked with black numerals and the positive with red.

Reposition the end shield in the fixture, locating the hole over the installing support.

With the installing adapter SP-3818 positioned on the rectifier, rotate the screw clockwise.

Guide the shank of the adapter into the screw. Continue to move the screw downward until just before bottoming.

CAUTION

Check carefully to be certain that the adapter is positioned properly over the rectifier and the rectifier is started squarely in the hole.

Rotate the screw clockwise pressing the rectifier in place until it bottoms. When the rectifier bottoms, it can easily be felt. Remove the end shield assembly from the fixture and inspect to see that rectifier is installed properly.

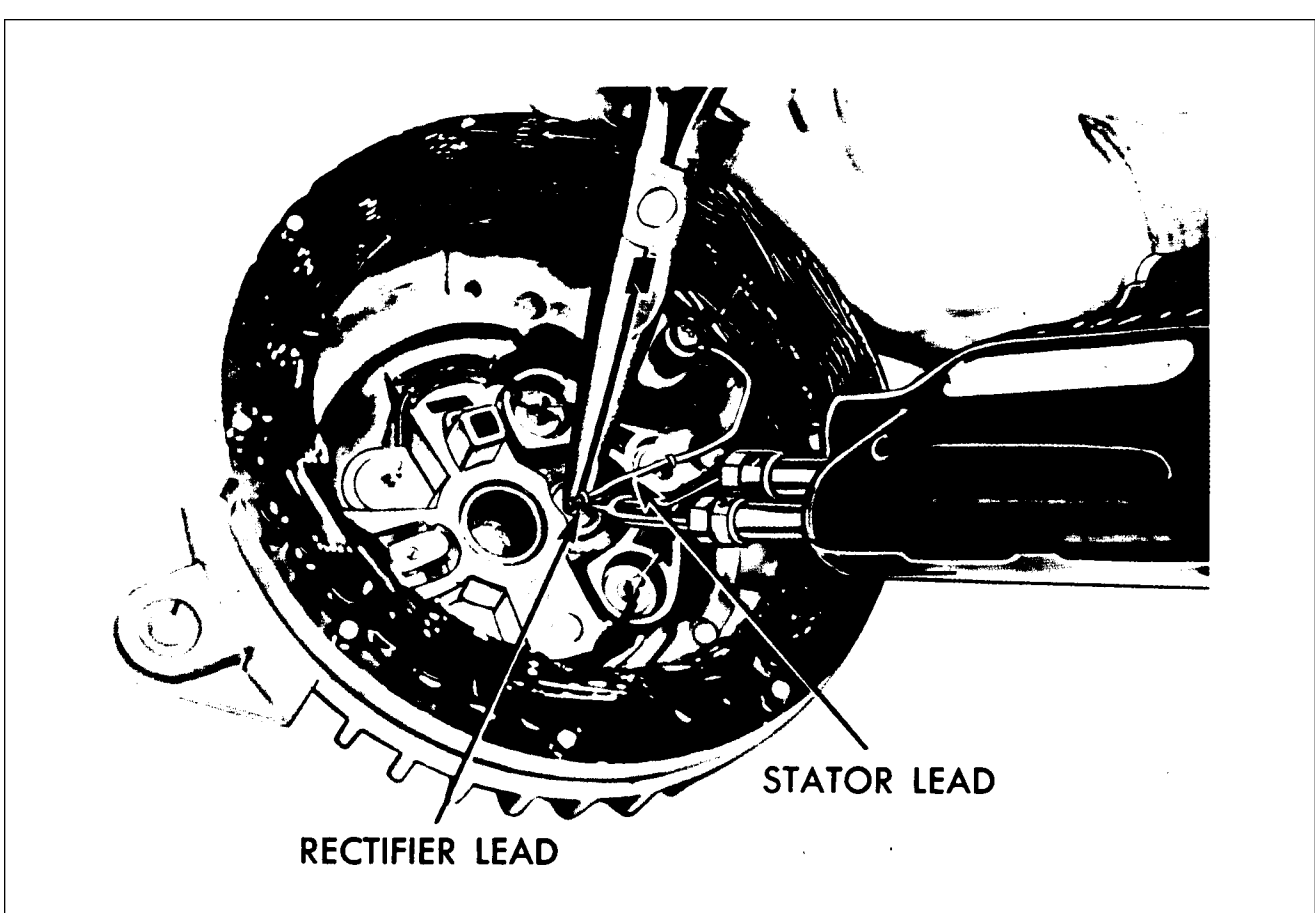

Figure 11-10. Soldering Rectifier Lead

NOTE

Clean all wires before soldering. Form the rectifier lead around the connector, being very careful not to crack the seal. To protect the rectifier from overheating, grip the rectifier lead between the rectifier and the point being soldered with a pair of long nose pliers. The pliers absorb heat to protect the rectifier. Under no circumstances use acid flux or acid core solder. Use rosin core solder only. The solder must be hot enough to flow and form a positive connection. Cold solder joints will break open. A good solder connection will be smooth while a poor solder joint (cold) will be rough and pitted.

NOTE

After soldering, to quickly cool the soldered connection, touch a dampened cloth against it. This will aid in forming a solid joint.

With the rectifier properly installed, test to ensure that the rectifier has not been damaged while installing. If the lead wires have been pulled away from the end shield, recement them.

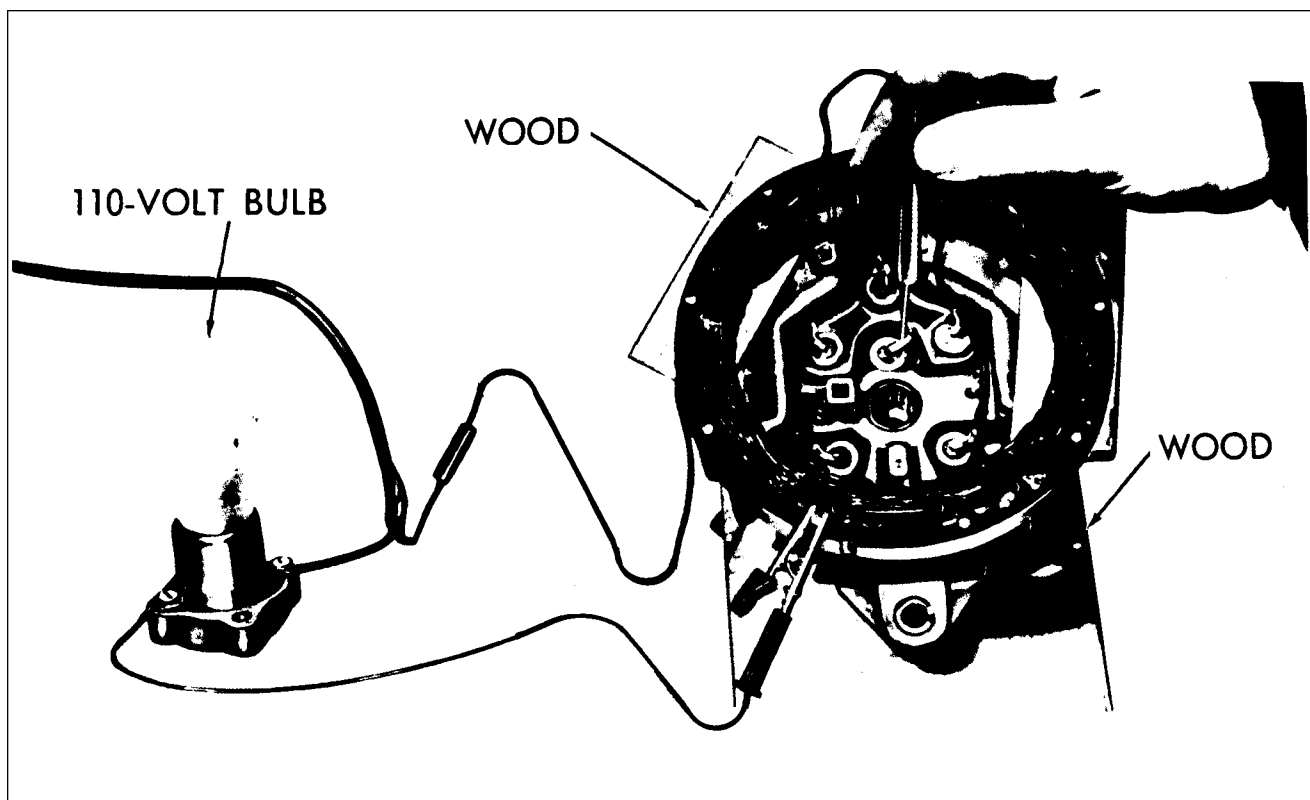

Figure 11-11. Testing Stator Coils

11-16. TESTING STATOR COILS FOR GROUND. The stator coils are insulated from the core. A break in the installation, allowing the bare wire to touch the core, will ground the coil and result in no output.

To test the stator for a ground (end shields separated), lift the stator away from the end shield and place wooden blocks approximately .50 inch thick between the stator and the shield to keep them separated.

Using a 110-volt test lamp, place one test probe on the core and the other test probe to one of the rectifier leads, making certain to have good electrical connections at both test probes. The lamp should not light. If the lamp lights, it is an indication that the coil windings are grounded to the core and a replacement of the stator is required.

11-17. TESTING ALTERNATOR CAPACITORS. Capacitors are used in connection with alternators to suppress any transient peak voltage that may occur. It is essential, therefore to test the capacitor when servicing the alternator.

This is especially true where diode rectifiers test open or short circuited.

The capacitor is connected to the inner end of the alternator "BAT" terminal screw and to the inner surface of the rectifier end shield (Ground).

Connect the capacitor tester to the alternator "BAT" terminal screw and the disconnected ground lead.

CAUTION

Do not allow the tester probes or clips to touch the end shield or the rectifier leads while the test is in progress or damage to the rectifiers may occur.

The specified capacity for the alternators (capacitor part of terminal screw) is $.5 \pm .1$ MFD (min.). Replace capacitors with low capacity, shorted or with high series resistance.

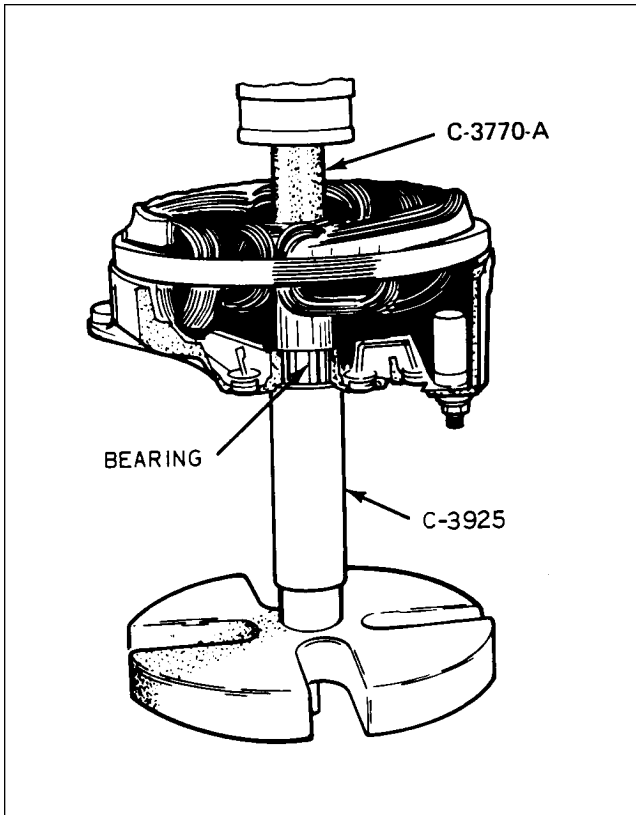

Figure 11-12. Removing End Bearing

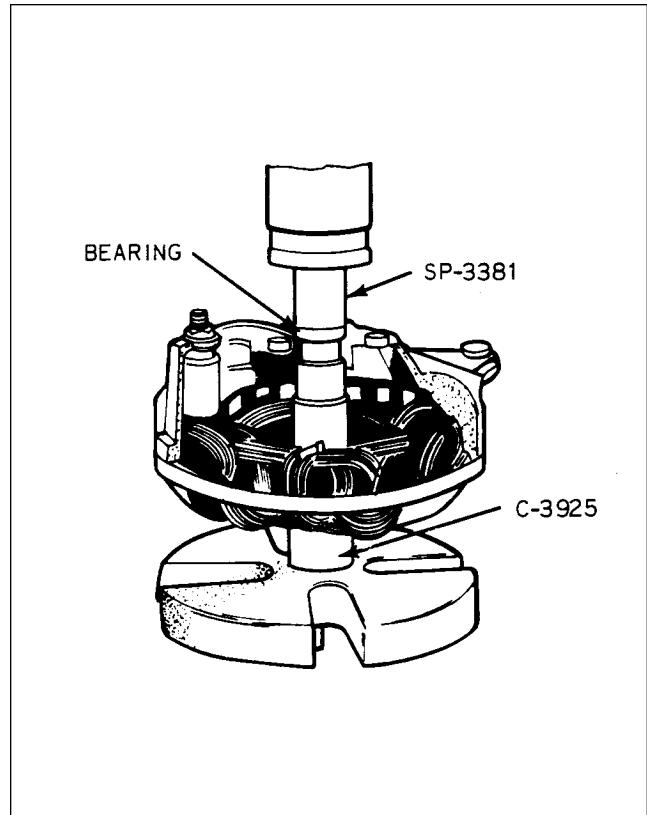

Figure 11-13. Installing End Bearing

11-18. REMOVING NEEDLE BEARING FROM END SHIELD. (Refer to Figure 11-12.) If inspection indicates that the needle bearing is faulty, it may be replaced.

The bearing is a press fit in the end shield. To protect the end shield, it is necessary to support it with tool C-3925 while pressing the bearing out with tool C-3770-A.

NOTE

Tool C-3925 is a double end tool. One end will only fit into the counterbore on alternators provided with the grease retainer. The opposite end is used as a support for end shields without the grease retainer counterbore.

11-19. INSTALLING NEEDLE BEARING IN END SHIELD. (Refer to Figure 11-13.) Support the end shield on the C-3925 tool and press the bearing into the end shield with tool SP-3381. Tool SP-3381 has a concaved end that is shaped to fit over the end of the bearing case. It is essential to use this tool to prevent damage to the bearing.

The face of the tool has been relieved to prevent pressure being applied on the center of the bearing. The use of a flat object to press in the bearing can cause the bearing to become distorted and result in a noisy bearing. Tool SP-3381 will also position the bearing properly. When the tool contacts the end shield the bearing is in the end shield, the proper distance.

NOTE

New bearings are prelubricated, additional lubrication is not required and should not be used.

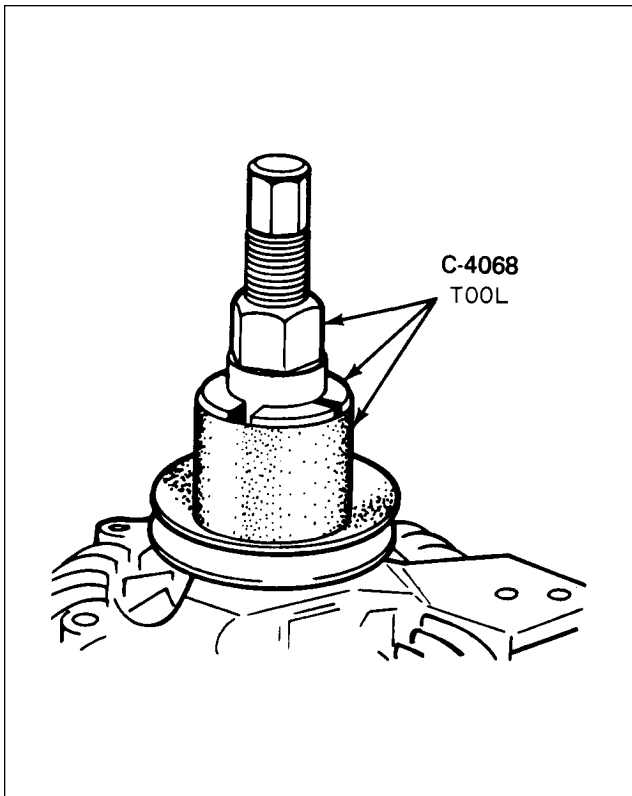

Figure 11-14. Removing Drive Pulley

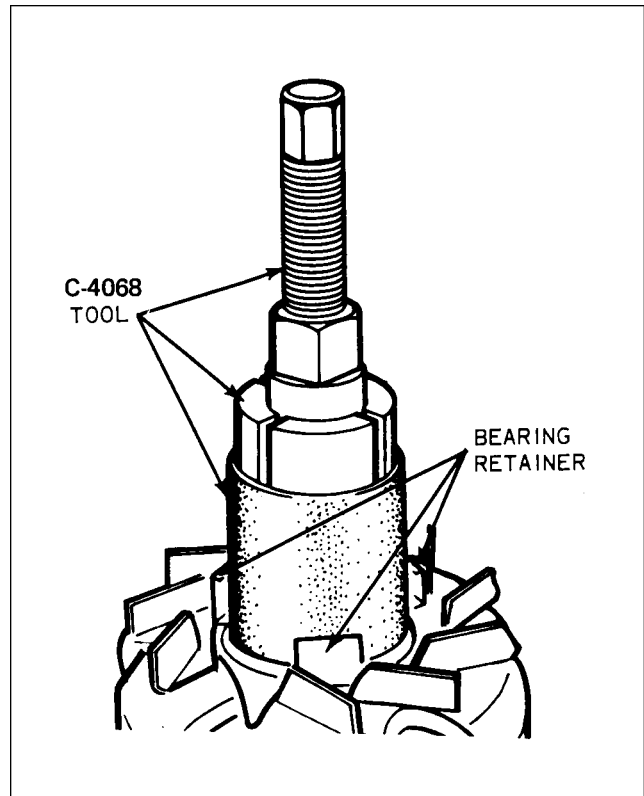

Figure 11-15. Removing Drive End Bearing

11-20. REMOVING DRIVE PULLEY. The drive pulley is an interference fit on the rotor shaft. The pulley is removed with puller C-4068. The use of this puller set to remove the pulley will prevent damage to the pulley.

11-21. REMOVING DRIVE END BEARING. The drive end bearing is an interference fit on the rotor shaft. It is also retained in the end shield by a retainer. The retainer is of spring steel construction and three integral fingers snap over a shoulder on the end shield.

Remove the drive end shield from the bearing by removing either the three retaining nuts from the retainer studs or by unsnapping the spring retainer fingers with a screwdriver. The end shield may then be removed by tapping on the end of the rotor shaft with a soft hammer while holding the end shield.

Remove the drive end bearing from the rotor shaft with puller C-4068 and special adapters as follows:

- a. Position the center screw of tool C-4068 on the rotor shaft.
- b. Place the thin lower end of the adapters SP-3375 under the bearing equally spaced and the upper end of the adapters around the center screw.
- c. Hold adapters and center screw in position with the tool sleeve.

CAUTION

Tool sleeve must bottom on bearing, otherwise adapters may be damaged.

- d. Turning the center screw while holding the outer body of the tool will withdraw the bearing from the shaft.

11-22. REPLACING SLIP RINGS. Slip rings that are damaged may be replaced. Rotor shafts are knurled and the slip rings are pressed on the knurled surface of the shaft. The rotor shaft has a grease retainer and an insulator. The retainer is pressed on over the insulator ahead of the slip rings.

CHEROKEE ARROW III SERVICE MANUAL

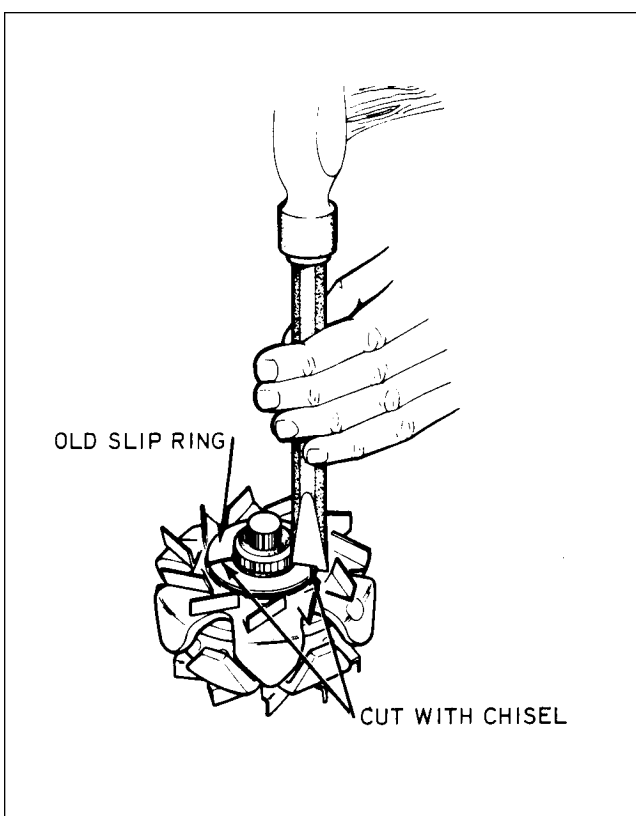

Figure 11-16. Removing Slip Ring

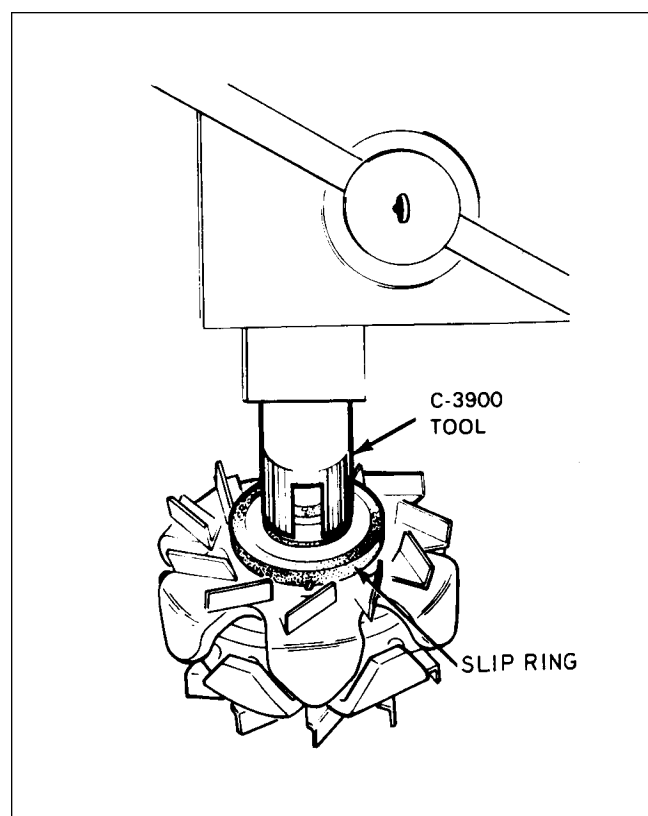

Figure 11-17. Installing Slip Ring

11-23. REMOVING SLIP RINGS. (Refer to Figure 11-16.)

- Unsolder the rotor coil (field) leads from the solder lugs.
- Remove grease retainer with a pair of diagonal pliers.
- Cut through the copper of both slip rings at opposite points (180° apart) with a chisel.
- Break the insulator and remove the ring.
- Clean away any dirt and all particles of the old ring.
- Scrape the face of the fan to be sure it is smooth.
- Clean the shaft surface on the area that contacts the inner diameter of the ring and also the ends of the rotor coil leads.

11-24. INSTALLATION OF SLIP RINGS. (Refer to Figures 11-17 and 11-18.)

- Position the slip ring on the rotor shaft so the solder lugs align with the rotor coil leads.
- Place assembly tool C-3900 over rotor shaft and slip ring.
- Position assembly in an arbor press and press the slip ring on the shaft until it bottoms on the rotor fan.
- Coil the insulated brush slip ring lead around the solder lug and solder securely with rosin core solder.
- Coil the ground brush ring field lead around the solder lug located 180° from the slip ring lug and solder with rosin core solder.
- Test slip rings for ground with 110-volt test lamp by touching one test probe to rotor pole shoe and remaining probe to slip rings. Test lamp should not light. If lamp lights, slip rings are shorted to ground, possible due to grounding insulated field lead when installing slip ring. If rotor is not grounded, lightly clean up slip ring surface with -00- sandpaper and assemble alternator.

CHEROKEE ARROW III SERVICE MANUAL

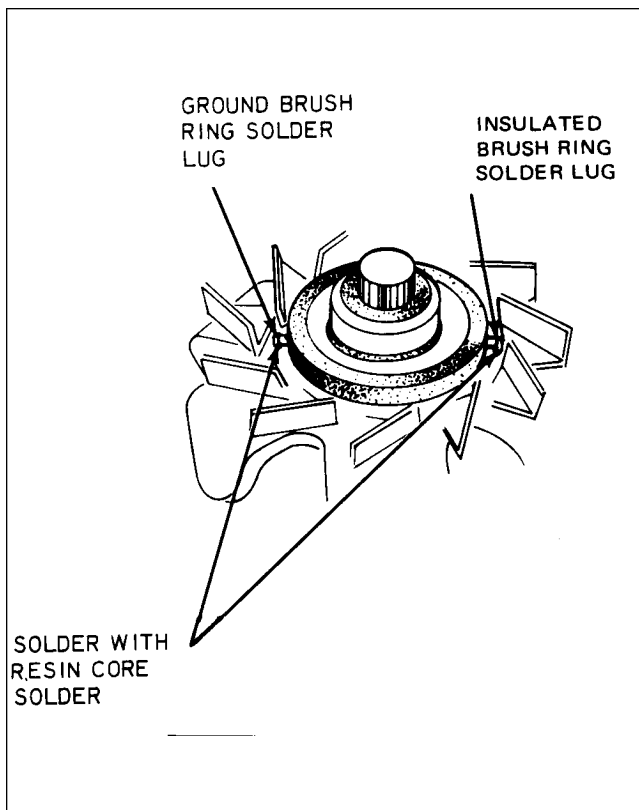

Figure 11-18. Solder Points

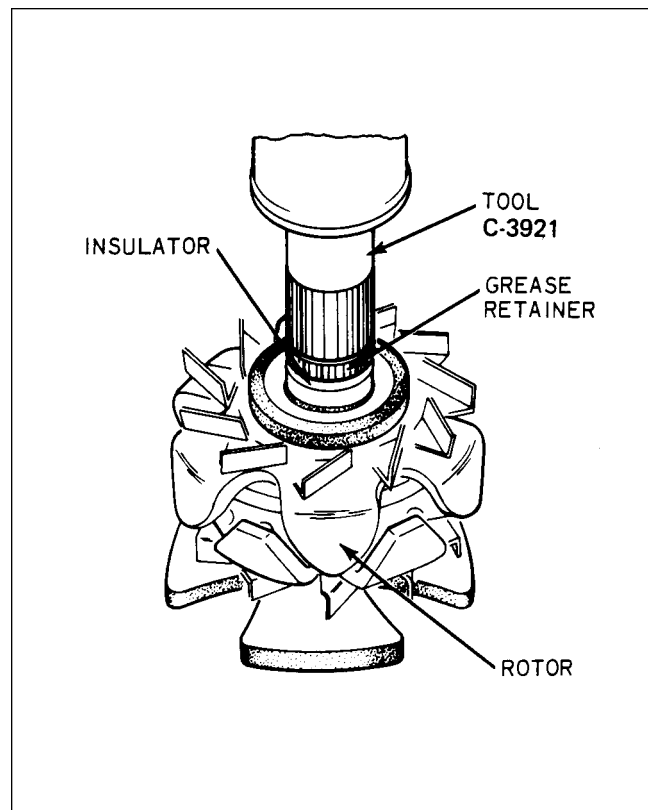

Figure 11-19. Installing Retainer

CAUTION

Under no circumstance use acid core solder. A short circuit may result and corrosion will definitely occur.

11-25. INSTALLING GREASE RETAINER. (Refer to Figure 11-19.) If the solder connection where the rotor field coil lead is soldered to the insulated brush ring lug has a sharp point or if the blob solder is excessive, smooth with a scraper or file before installing the grease retainer insulator. If smooth, place fibre insulator on shaft and press the retainer (cupped side to end of shaft) on the shaft with tool C-3921 in an arbor press.

11-26. INSTALLING DRIVE END BEARING. (Refer to Figure 11-20.) Insert the sealed drive end bearing in the drive end shield and install the bearing retainer. Install the washers and nuts to hold the bearing in place on all early production. Snap the spring steel retainer fingers in place on all later production models.

If the rotor and its components require no service, position the bearing and the drive end shield assembly on the rotor shaft and while supporting the parts on the end of the rotor shaft, press the bearing and end shield assembly in position on the rotor shaft using an arbor press and tool C-3858.

CAUTION

Make sure that the bearing is installed squarely at the start; otherwise, damage to the bearing will result. Press the bearing on the rotor shaft until the bearing contacts the shoulder on the rotor shaft.

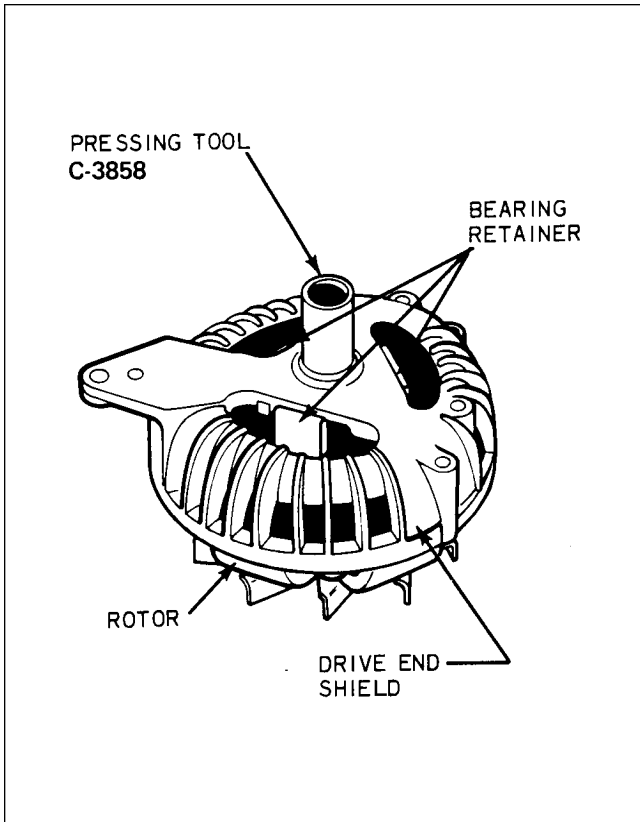

Figure 11-20. Installing Drive End Shield and Bearing (Typical)

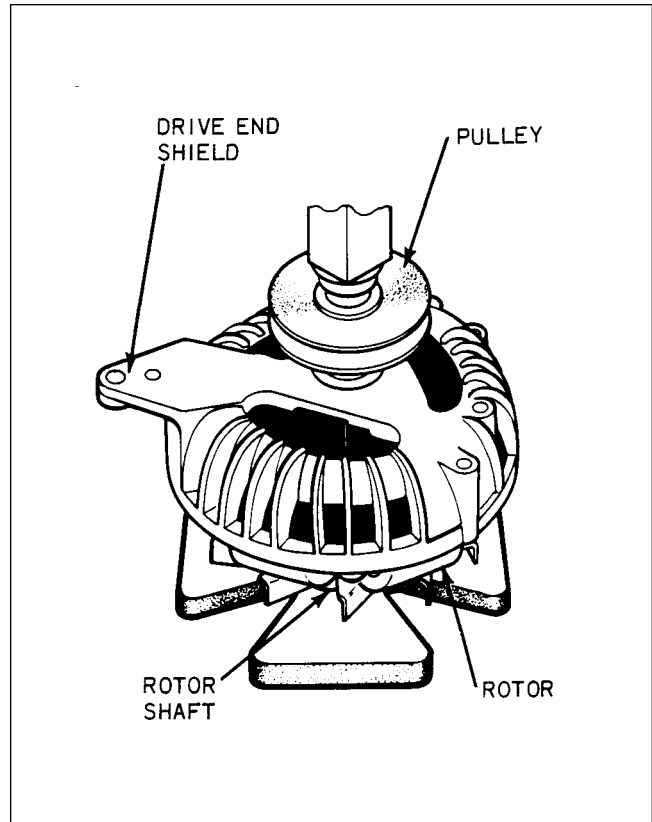

Figure 11-21. Installing Pulley

11-27. **INSTALLING PULLEY.** (Refer to Figure 11-21.) Install pulley on the rotor shaft using an arbor press before the rectifier end shield is assembled to the drive end shield.

WARNING

Do not press pulley on with a vise. Use a press.

The shaft must be the support while the pulley is pressed on with the pressure being applied to the pulley hub.

NOTE

Do not exceed 6800 pounds pressure. Press the pulley on the rotor shaft until the pulley contacts the inner face of the drive end bearing.

11-28. **ASSEMBLING END SHIELD SUB-ASSEMBLIES.** Position the rotor and drive end shield assembly on the rectifier end shield. Align the through bolt holes through the drive end shield, stator and the rectifier end shield.

Compress stator and both end shields by hand and install the through bolts.

Install the insulated brush and holder, terminal, insulating washer, lockwasher and terminal attaching screw. Install the ground brush and attaching screw.

Rotate the pulley slowly by hand to be sure that the rotor fans do not hit the rectifiers and stator connectors.

After installing the alternator on the engine, always test the complete charging system to be certain it is functioning properly.

NOTE

New through bolt locking tabs should be installed at each alternator disassembly. Torque through bolts evenly to 25 inch pounds and bend both ears of the locking tabs against bolt head. Check proper belt tension.

11-29. BENCH RUN-UP TEST. This test is to be performed at room ambient conditions and consists of four checks which are to be made quickly to avoid heating of the windings. These are as follows:

NOTE

For test c and d, external field excitation may be used but must be removed and self excitation used to obtain output amperes. (Refer to Figure 11-22 for meter connections.)

- a. With the alternator at rest, supply 15-volts between the alternator battery terminal and ground with polarity such that the rectifiers will block current flow (positive of supply to positive of the alternator). Monitor rectifier reverse current which shall be not more than 1 milliampere.
- b. With the alternator at rest, apply 15-volts to the field circuit and monitor field current. This shall be between the limits of 3.3-amperes minimum and 3.6-amperes maximum.
- c. Drive the alternator at 1500 rpm with an electrical load connected to the alternator. Adjust the load to obtain 15-volts. Net output (not including field current) shall be not less than 26.5-amperes.
- d. Drive the alternator at 2500 rpm with an electrical load connected to the alternator. Adjust the load to obtain 15-volts. Net output (not including field current) shall be not less than 49.0-amperes.

11-30. BENCH HOT STABILIZATION OUTPUT TEST. To determine the hot stabilized output, the alternator must be driven with a suitable driving mechanism. During this test, the following shall be monitored: (Refer to Figure 11-22 for meter connections.)

- a. Alternator output voltage.
- b. Alternator output current.
- c. Field current.
- d. Alternator rpm.

Drive the alternator at sufficient rpm to obtain 14-volts at the alternator battery terminal. Alternator shall be self excited, otherwise no external load shall be applied. An external DC power source may be used to polarize the field but must be removed as soon as the alternator is self sustaining. Maintain 14-volts at no load by adjusting rpm for a period of 15 minutes, at which time record the above specified data.

Apply an electrical load to the alternator and increase speed so as to obtain 5-amperes output (not including field excitation) at 14-volts. Maintain this condition for 15 minutes by adjusting the rpm. At the end of this period, record the above specified data.

Maintain output voltage at 14-volts and vary the load in 5-ampere intervals. At each 5-amp intervals, allow a 15 minute stabilization period maintaining output by varying rpm. Record the required data at each interval. Continue this procedure through the maximum output (approximately 10,000 rpm).

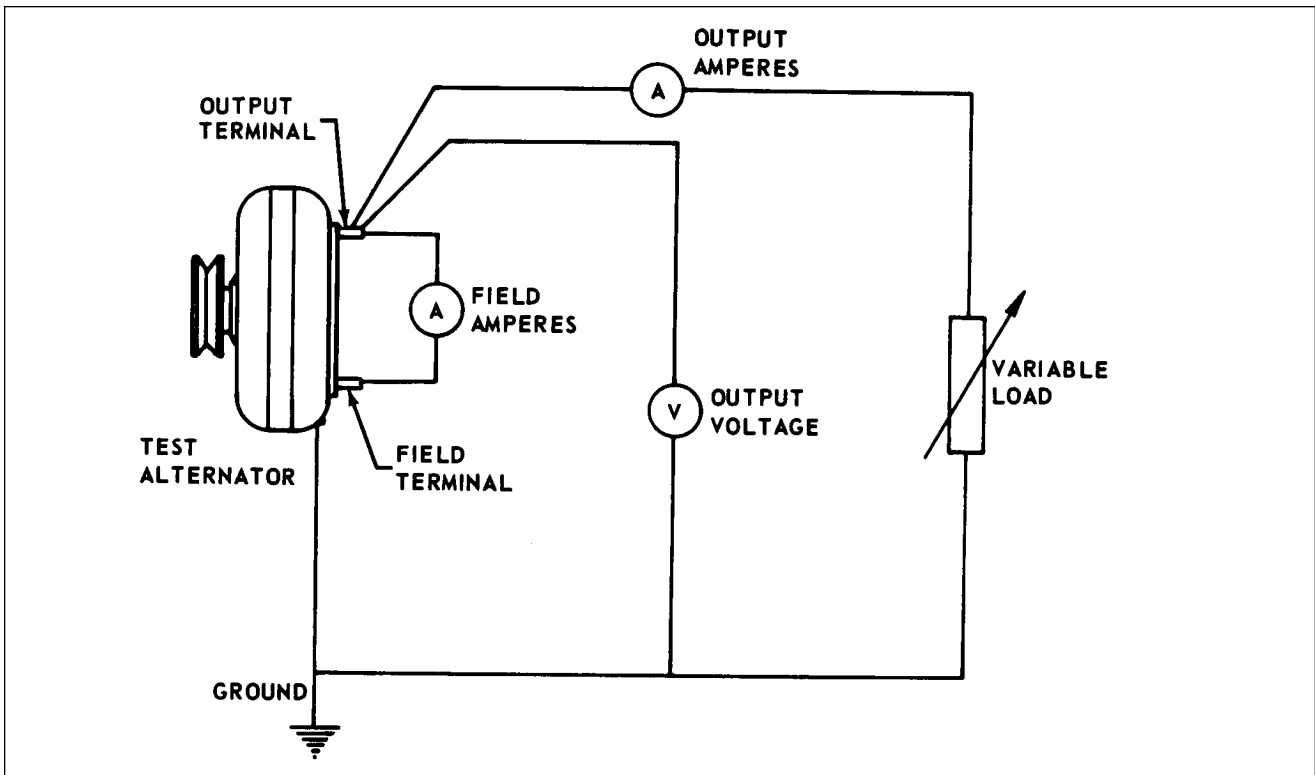

Figure 11-22. Meter Connections for Alternator Performance Test

11-31. CHECK ALTERNATOR BELT TENSION. If properly installed, tensioned and checked periodically, the alternator drive belt will give very satisfactory service. However, an improperly tensioned belt will wear rapidly and may slip and reduce alternator output. Consequently, a belt should be checked for proper tension at the time it is installed, again after 25 hours operation and at each 100 hour inspection thereafter.

The torque method for checking alternator belt tension is given as follows:

- a. Apply a torque indicating wrench to the nut that attaches the pulley to the alternator and turn it in a clockwise direction. Observe the torque shown on the wrench at the instant the pulley slips.
- b. Check the torque indicated in step "a" with torque specified in the following chart. Adjust tension accordingly.

TABLE XI-I. ALTERNATOR BELT TENSION

Width of Belt	Condition	Torque indicated at alternator pulley
3/8 inch	New	11 to 13 ft.-lbs.
3/8 inch	Used	7 to 9 ft.-lbs.

CHEROKEE ARROW III SERVICE MANUAL

NOTE

The higher tension specified for a new belt is to compensate for the initial stretch that takes place as soon as it is operated. These higher tension values should not be applied to belts which have previously been used.

11-32. ALTERNATOR SYSTEM (PRESTOLITE).

WARNING

When servicing or inspecting vendor equipment installed in Piper aircraft, it is the user's responsibility to refer to the applicable vendor publication.

- a. Bearings: These units have a sealed ball bearing at the drive end and a two-piece roller bearing at the slip ring end. The inner race is pressed onto the rotor shaft and the rest of the bearing is in the slip ring end head. When the unit is assembled, the inner race aligns with the bearing. When the bearing is replaced, the new inner race must be installed on the rotor shaft.
- b. Lubrication: The slip ring end bearing should be lubricated whenever the alternator is disassembled. The bearing should be thoroughly cleaned and repacked with Shell Alvania No. 2 or an equivalent bearing lubricant. The cavity behind the bearing should be packed one-third to one-half full with the same lubricant.
- c. Brushes: These units have a separate brush holder assembly that is installed after the alternator has been assembled. The brush holder has a small hole that intersects the brush cavities. Use a pin or a piece of wire, as shown in Figure 11-35, to hold the brushes in the holder during assembly. Remove the pin after the brush holder retaining screws have been tightened. Make a continuity check to be sure the brushes are seated against the slip rings.
- d. Drive Pulley: On PA-28R-201, torque the drive pulley retaining nut to 35 foot-pounds.

11-34. ALTERNATOR SERVICE PRECAUTIONS. Since the alternator and regulator are designed for use on only one polarity system, the following precautions must be observed when testing or servicing the electrical system. Failure to observe these precautions will result in serious damage to the electrical equipment.

- a. Disconnect the battery before connecting or disconnecting test instruments (except voltmeter) or before removing or replacing any unit or wiring. Accidental grounding or shorting at the regulator, alternator, ammeter or accessories, will cause severe damage to the units and/or wiring.
- b. The alternator must not be operated on open circuit with the rotor winding energized.
- c. Do not attempt to polarize the alternator. No polarization is required. Any attempt to do so may result in damage to the alternator, regulator or circuits.
- d. Grounding of the alternator output terminal may damage the alternator and/or circuit and components.
- e. Reversed battery connections may damage the rectifiers, wiring or other components of the charging system. Battery polarity should be checked with a voltmeter before connecting the battery. Most aircraft are negative ground.
- f. If a booster battery or fast charger is used, its polarity must be connected correctly to prevent damage to the electrical system components.
- g. When using an auxiliary power unit, make sure the voltage and polarity are set to correspond with the aircraft system voltage and polarity.

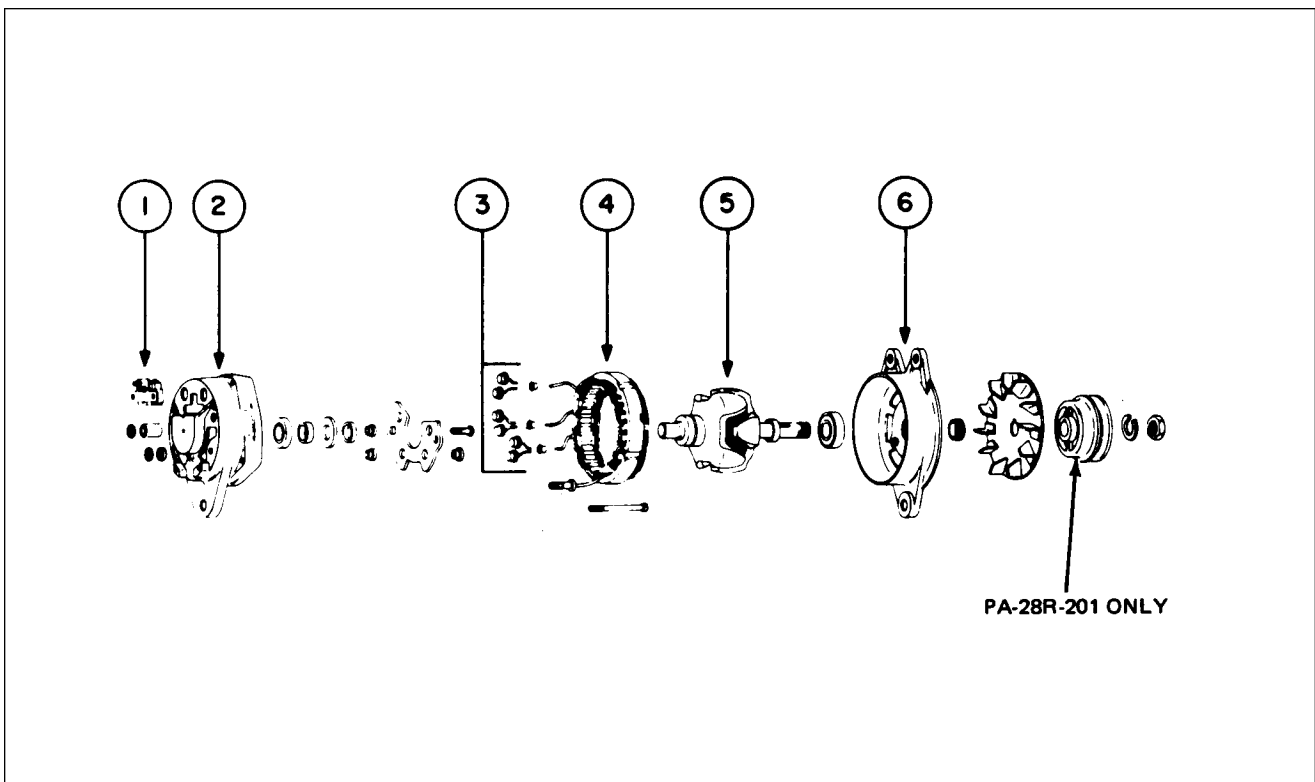

Figure 11-23. Exploded View of Alternator.

11-35. DESCRIPTION OF ALTERNATOR. (Refer to Figure 11-23.)

The principal components of the alternator are the brush holder assembly (1), the slip ring end head (2), the rectifiers (3), the stator (4), the rotor (5) and the drive end head (6).

- a. The brush holder assembly contains two brushes, two brush springs, a brush holder and insulator. One brush is connected to a terminal stud and is insulated from ground. The other brush is connected to ground through the brush holder. The brush and holder assembly can easily be removed for inspection or brush replacement purposes.
- b. The slip ring end head provides the mounting for the rectifiers and rectifier mounting plate, output and auxiliary terminal studs, and the brush and holder assembly. The slip ring end head contains a roller bearing and outer race assembly and a grease seal.
- c. The rectifiers used in these units are rated at 150 peak inverse voltage (P.I.V.) minimum for transient voltage protection. Three positive rectifiers are mounted in the rectifier mounting plate while the three negative rectifiers are mounted in the slip ring end head. Each pair of rectifiers is connected to a stator lead with high temperature solder. The stator leads are anchored to the rectifier mounting plate with epoxy cement for vibration protection.
- d. The stator contains a special lead which is connected to the center of the three phase windings. The stator has been treated with a special epoxy varnish for high temperature resistance.
- e. The rotor contains the slip ring end bearing inner race and spacer on the slip ring end of the shaft. The rotor winding and winding leads have been specially treated with a high temperature epoxy cement to provide vibration and temperature resistance characteristics. High temperature solder is used to secure the winding leads to the slip rings.
- f. The drive end head supports a sealed, prelubricated ball bearing in which the drive end of the rotor shaft rotates.

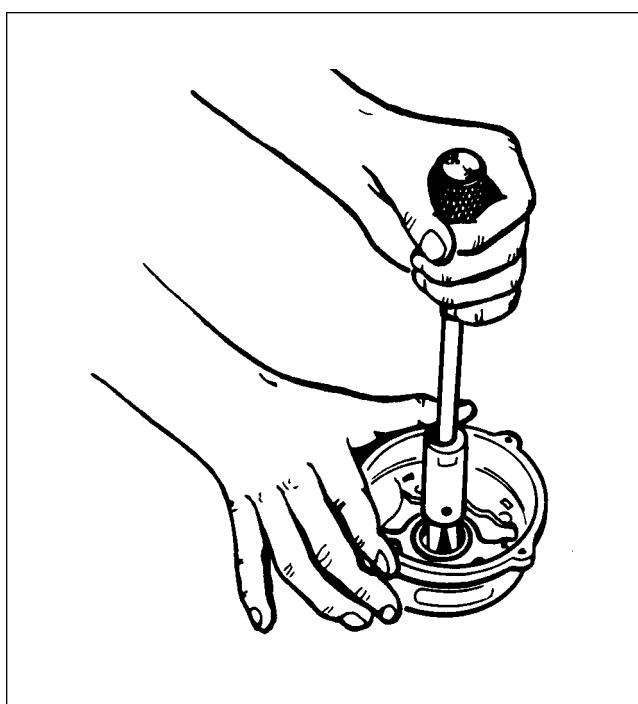

Figure 11-24. Removal of Slip Ring End Bearing

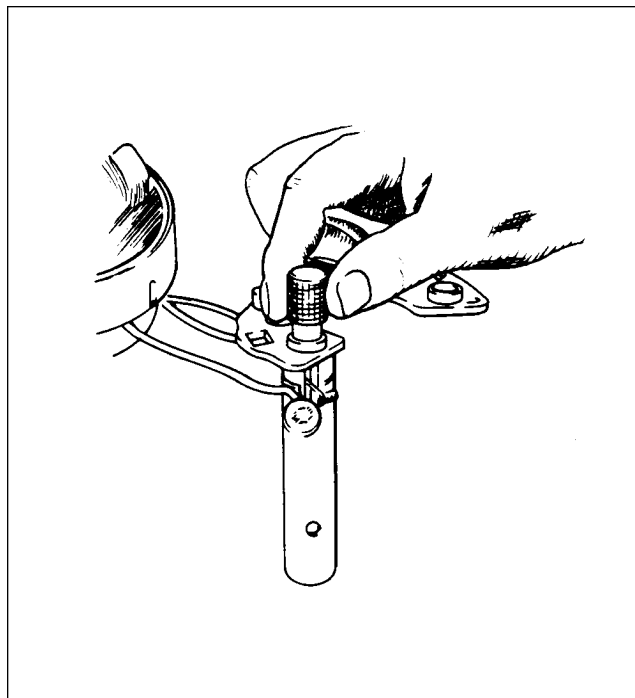

Figure 11-25. Removal of Rectifier

11-36. OVERHAUL OF ALTERNATOR. When repairing the alternator, complete disassembly may not be required. In some cases, it will only be necessary to perform those operations which are required to effect the repair. However, in this section, the complete overhaul is covered step-by-step to provide detailed information on each operation. In actual service practice, these operations may be used as required.

11-37. DISASSEMBLY OF ALTERNATOR.

- a. Remove the two Number 10-24 screws holding the brush holder assembly in the slip ring end head. Remove the brush and holder assembly from the end head.
- b. Remove the safety wire from the through bolts.
- c. On PA-28R-201, hold the pulley with a strap wrench and remove the pulley nut. The pulley must be removed with a puller. Remove the fan, woodruff key and spacer from the shaft.
- d. Remove the four through bolts and tap the drive end head lightly to separate the drive end head and rotor, as a unit, from the stator and slip ring end head.
- e. Remove the nuts, lockwashers, flat washers and insulators from the output and auxiliary terminal studs. Note carefully the correct assembly of the insulator washers and bushings. Using the special tools shown in Figure 11-25, support the end head and press out the three negative rectifiers. The end head can now be separated from the stator assembly.
- f. To remove the slip ring end bearing and grease seal, it will be necessary to have a hook type or impact type bearing puller as shown in Figure 11-24. Do not remove the bearing unless replacement is necessary.

NOTE

The inner race of the slip ring end bearing is pressed onto the rotor shaft. When bearing replacement is necessary, always replace the complete bearing assembly, including the inner race.

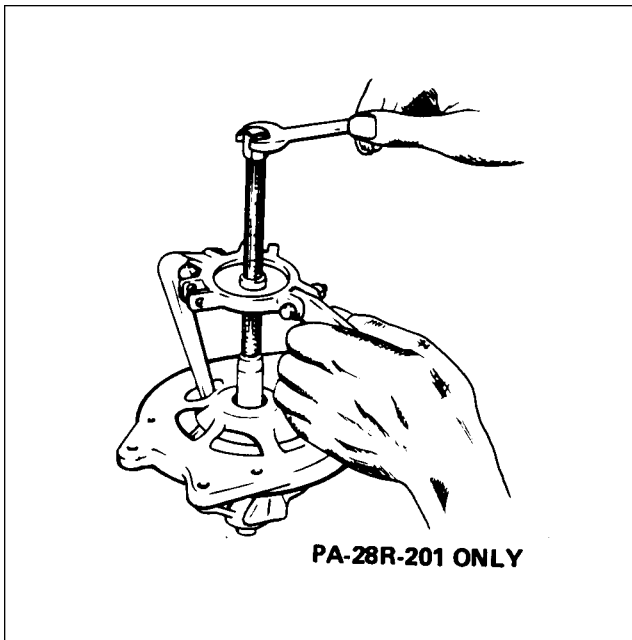

Figure 11-26. Removal of Drive End Head

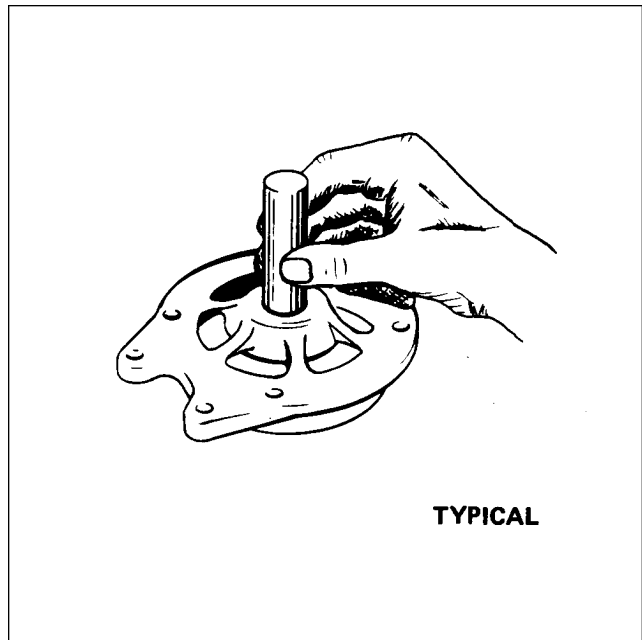

Figure 11-27. Removal of End Head Bearing

- g. On PA-28R-201 models, to remove the drive end head from the rotor shaft, use a puller that grips on the bearing retainer plate as shown in Figure 11-26. Do not attempt to remove by supporting the end head and pressing on the shaft as this may result in distortion of the end head or stripping of the retainer plate screws. Remove the three retainer plate screws and press the bearing out of the end head. (Refer to Figure 11-27.) On PA-28R-201T models, support the drive end head and carefully press out the rotor assembly. Remove the three retainer plate screws and press the bearing from the end head. (Refer to Figure 11-27.)

11-38. INSPECTION AND TESTING OF COMPONENTS. Upon completion of the disassembly, all parts should be cleaned and visually inspected for cracks, wear or distortion and any signs of overheating or mechanical interference.

- a. Rotor: The rotor should be tested for grounded or shorted windings. The ground test can be made with test probes, connected in series with a 110-volt test lamp, an ohmmeter or any type of continuity tester. (Refer to Figure 11-28.) There must not be any continuity between the slip rings and the rotor shaft or poles. To test for shorted turns in the rotor windings, connect a voltmeter, ammeter and rheostat as shown in Figure 11-29, or use an ohmmeter. Rotor current draw and resistance are listed in the Alternator Service Test Specifications paragraph. Excessive current draw or a low ohmmeter reading indicates shorted windings. No current draw or an infinite ohmmeter reading would indicate an open winding.
- b. Rectifiers: A diode rectifier tester will detect and pin point open or shorted rectifiers without going through the operation of disconnecting the stator leads. However, if a tester is not available, test probes and a No. 57 bulb, connected in series with a 12-volt battery, can be used in the following manner. Touch one test probe to a rectifier heat sink and the other test probe to a lead from one of the rectifiers in that heat sink. Then reverse the position of the leads. The test bulb should light in one direction and not light in the other direction. If the test bulb lights in both directions, one or more of the rectifiers in the heat sink is shorted. To pin point the defective rectifier, the stator leads must be disconnected and the above test repeated on each rectifier. Open rectifiers can only be detected, when using the test bulb, by disconnecting the stator leads. The test bulb will fail to light in either direction if the rectifier is open.

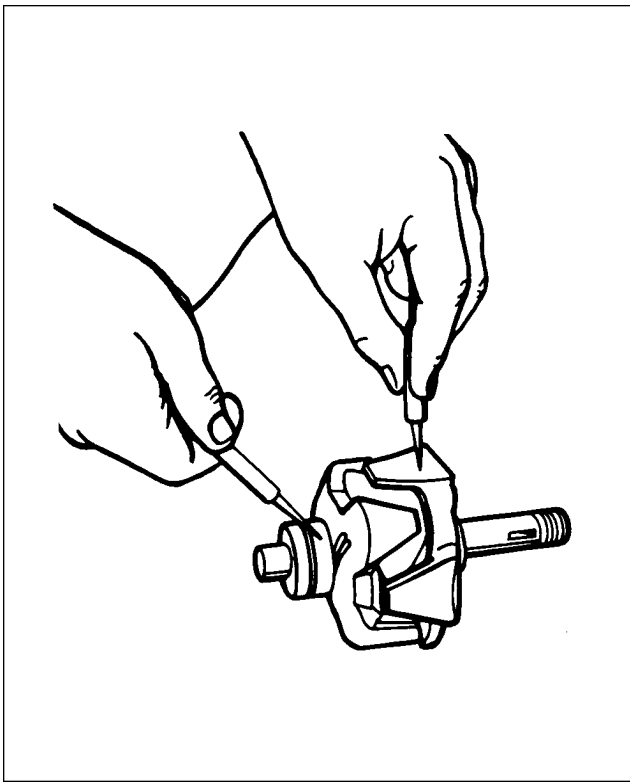

Figure 11-28. Testing Rotor for Ground

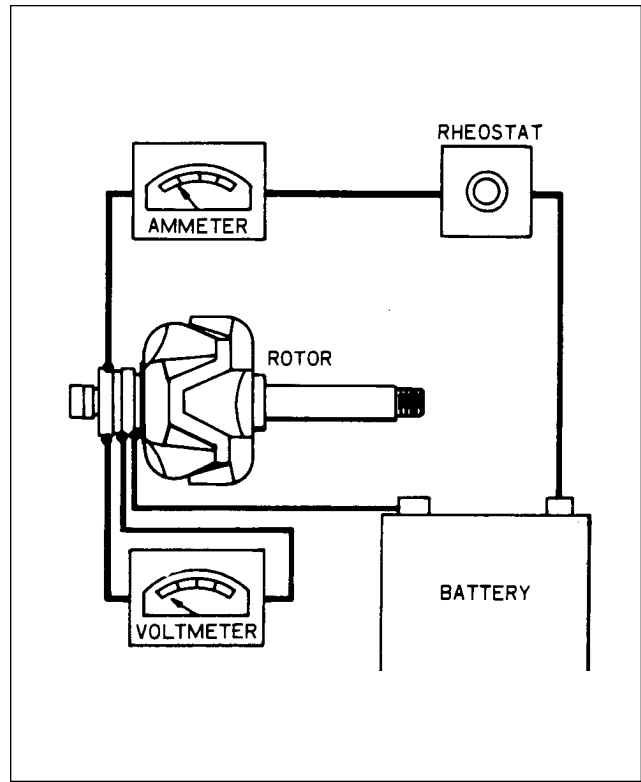

Figure 11-29. Testing Rotor for Shorts

- c. Stator: The stator can be tested for open or grounded windings with a 12-volt test bulb, described in the rectifier section, or an ohmmeter, in the following manner. Separate the stator from the slip ring end head just far enough to insert a fold of rags or blocks of wood. In other words, insulate the stator from the end head. To test for grounded windings, touch one test bulb or ohmmeter probe to the auxiliary terminal or any stator lead and the other test bulb or ohmmeter probe to the stator frame. If the test bulb lights, or the ohmmeter indicates continuity, the stator is grounded. To test for open windings, connect one test probe to the auxiliary terminal or the stator winding center connection and touch each of the three stator leads. The test bulb must light or the ohmmeter must show continuity. Due to the low resistance in the stator windings, shorted windings are almost impossible to locate. However, shorted stator windings will usually cause the alternator to “growl” or be noisy during operation and will usually show some signs of overheating. If all other electrical checks are normal and alternator fails to supply its rated output, the stator should be replaced to determine whether or not it is the faulty component.
- d. Bearings and Seals: Whenever the alternator is overhauled, new bearings and oil or grease seals are recommended, even though the bearings and seals appear to be in good condition. A faulty seal can cause an alternator to fail within a very short period of time.

11-39. ASSEMBLY OF ALTERNATOR.

- a. Press the ball bearing into the drive end head using a flat block approximately two inch square so that the pressure is exerted on the outer race of the bearing. Install the retainer plate. With the snap ring and retainer cup in place on the rotor shaft, use a tool that fits over the shaft and against the inner bearing race, and press until the inner bearing race is against the snap ring retainer cup. (Refer to Figure 11-30.)
- b. Carefully install the rectifiers in the slip ring end head or rectifier mounting plate by supporting the unit and using the special tools illustrated in Figure 11-31.



Figure 11-30. Installation of Drive End Head

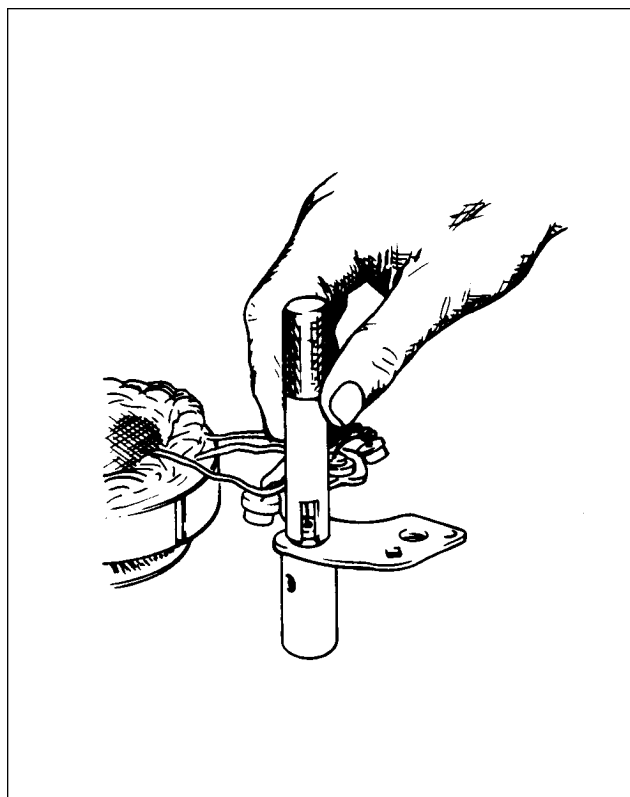

Figure 11-31. Installation of Rectifier

CAUTION

Use an arbor press, do not hammer. Reconnect the stator leads to the rectifiers. When soldering these connections, use pliers as a heat dam on the lead between the solder point and the rectifier. Too much heat will damage the rectifiers.

- c. Reassemble the rectifier mounting plate studs and insulators, making sure they are in the correct order. (Refer to Figure 11-32.)
- d. After the slip ring end head is completely assembled, the stator and rectifier leads must be secured to the rectifier mounting plate with epoxy. Make sure the stator leads are positioned so that they do not interfere with the rotor.
- e. Install the slip ring end bearing and oil seal. Make sure the lip of the oil seal is toward the bearing. Stake the seal in place. Correct assembly of bearing, seal, inner race and spacer as shown in Figure 11-33.
- f. Assemble the alternator and install the through bolts. Spin the rotor to make sure there is no mechanical interference. Torque the through bolts to 30 to 35 inch-pounds. Safety wire should be installed after the unit has been bench tested for output.
- g. On PA-28R-201, install spacer, woodruff key, fan, pulley, lockwasher and nut. Torque the nut to 35 foot pounds, using a strap wrench to hold the pulley.
- h. Install the brush and holder assembly and retaining screws. Spin the rotor and check for interference between the brush holder and rotor. Check between the field terminal and ground with an ohmmeter. The ohmmeter must indicate the amount of rotor resistance listed with paragraph 11-41, Alternator Service Test Specifications.

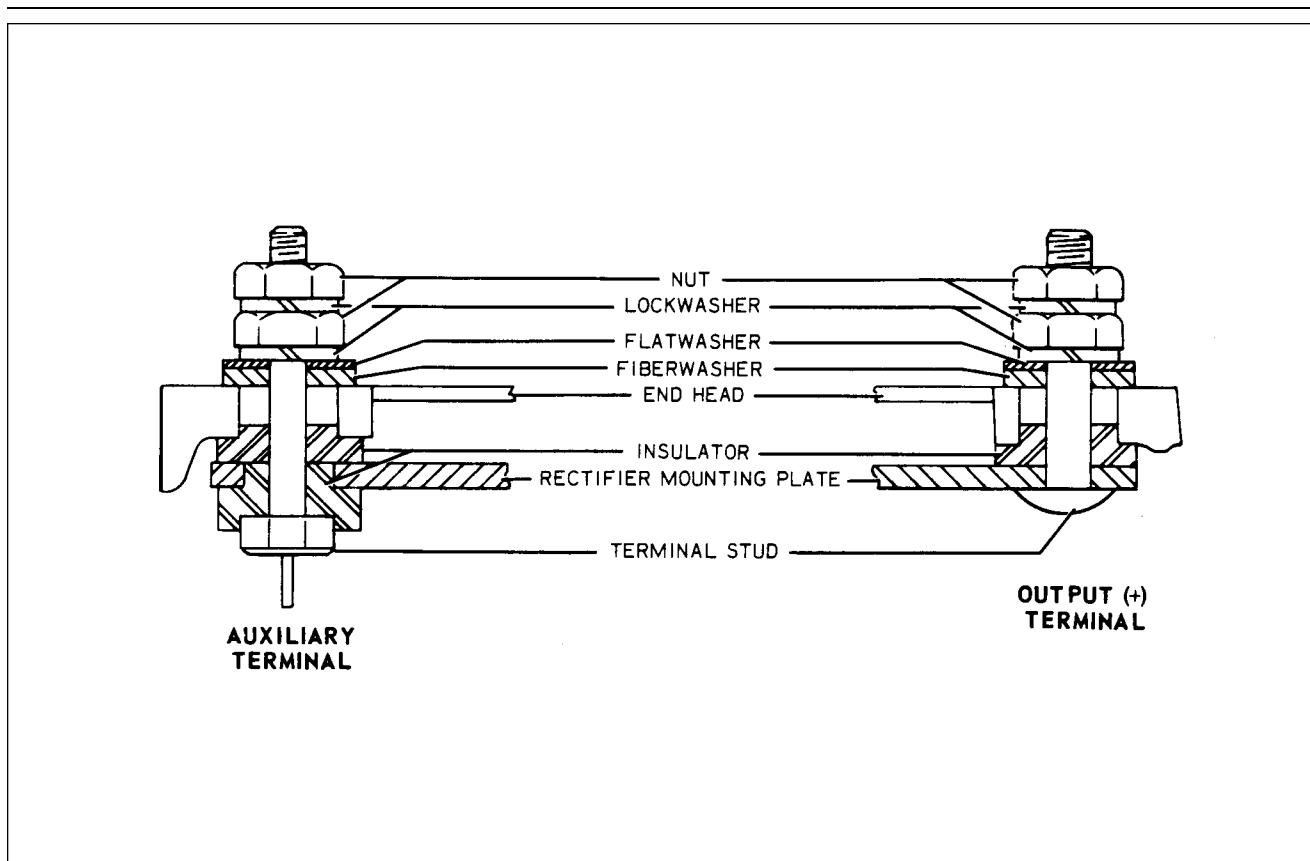

Figure 11-32. Terminal Assembly

11-40. TESTING OF ALTERNATOR.

- a. Wiring connections for bench testing the alternator are shown in Figure 11-34. Refer to the individual specification pages for output test figures. Adjust the carbon pile, if necessary, to obtain the specified voltage.
- b. After bench testing the alternator, install the safety wire and install the alternator on the engine.

NOTE

Always refer to the wiring diagram when installing the alternator or testing the alternator.

CAUTION

Do not test alternators used on PA-28R-201T at full rated output for more than 30 seconds unless adequate-air pressure for cooling is supplied.

11-41. ALTERNATOR SERVICE TEST SPECIFICATION. Prestolite specifications for the 14-volt alternators installed on PA-28R-201T. Prestolite alternators are also used on PA-28R-201 airplanes equipped with air conditioning.

CHEROKEE ARROW III SERVICE MANUAL

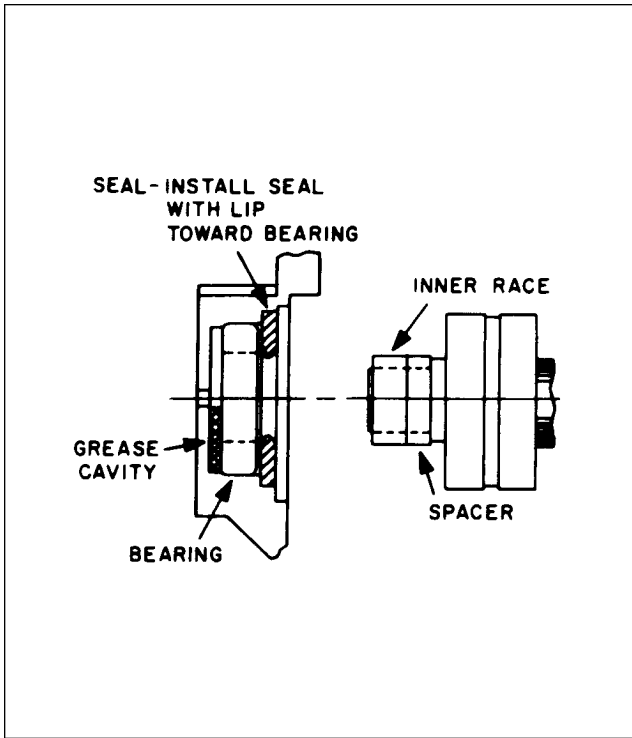

Figure 11-33. Slip Ring End Bearing Assembly

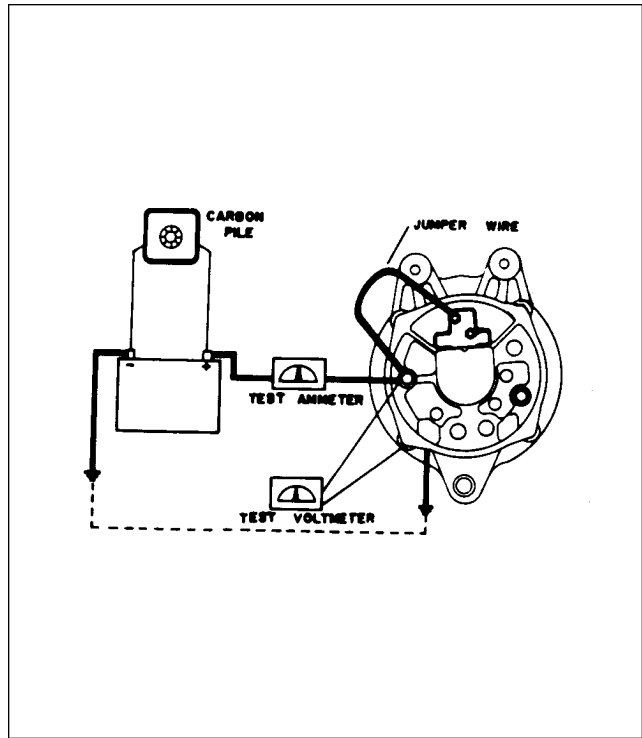

Figure 11-34. Testing Alternator

TABLE XI-II. ALTERNATOR SPECIFICATIONS

<u>Aircraft Model</u> Alternator Model	<u>PA-28R-201</u> ALY 6422	<u>PA-28R-201T</u> ALX 9425A
Voltage	12-volts	12-volts
Rated Output	60 amperes	65 amperes
Ground Polarity	Negative	Negative
Rotation	Bi-Directional	Bi-Directional
Rotor Current Draw (77°F) Resistance (77°F)	3.0 to 3.3 amps @ 12.0-volts 3.6 to 3.9 ohms	2.4 to 4.0 amps @ 12.0-volts 3.0 to 5.0 ohms
Output Test (77°F) Volts Amperes Output Field Amperes Alternator RPM	12.8 14.2 10.0 65.2 3.15 3.45 1730 min. 5000 min.	

CHEROKEE ARROW III SERVICE MANUAL

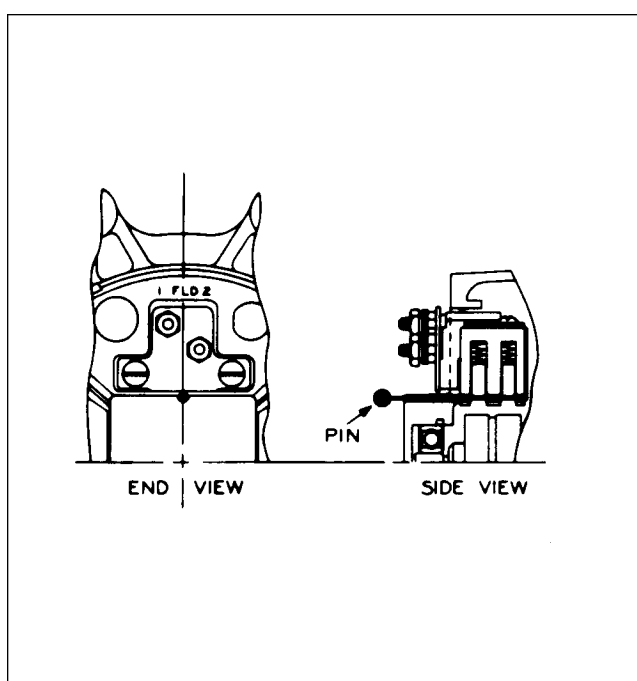

Figure 11-35. Brush Installation

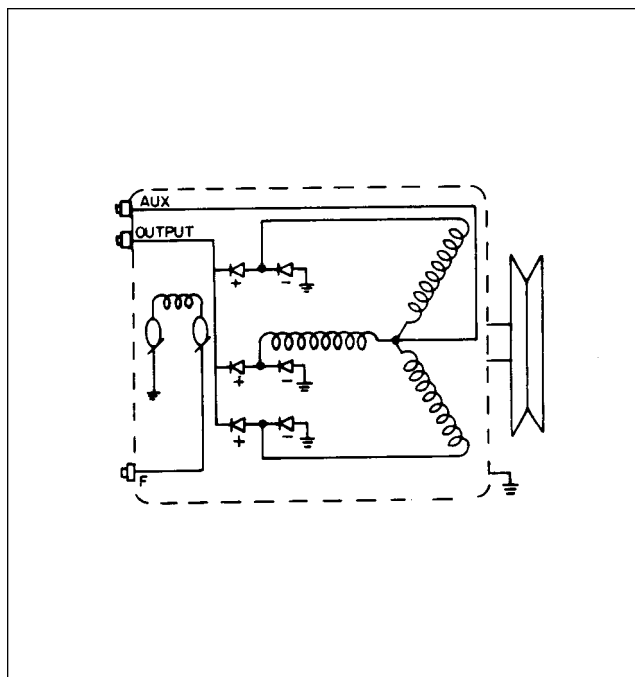

Figure 11-36. Internal Wiring Diagram

11-42. CHECK ALTERNATOR BELT TENSION. PA-28R-201. For aircraft with air conditioning installed, see Paragraph 14-22, Section XIV, Replacement of Compressor and/or Alternator Drive Belts.

11-43. VOLTAGE REGULATOR. (Wico)

11-44. CHECKING VOLTAGE REGULATOR. The regulator is a fully transistorized unit in which all of the components are encapsulated in epoxy, which makes field repair of the unit impractical, and if it does not meet the specifications, it must be replaced. The regulator may be tested by the following procedure:

- a. Be sure that the battery is fully charged and in good condition.
- b. Check the alternator according to the manufacturer's instructions to determine if it is functioning properly. This test must be done with the regulator out of the circuit. After completing this test, reconnect the regulator into the circuit.
- c. Use a good quality accurate voltmeter with at least a 15-volt scale.
- d. Connect the positive voltmeter lead to the red wire at the regulator harness connector or terminal block. Connect the negative voltmeter lead to the regulator housing. (Note) Do not connect the voltmeter across the battery because the regulator is designed to compensate for resistance contained within the wiring harness.
- e. With the alternator turning at sufficient rpm to produce a half load condition, or approximately 25 amperes output, the voltmeter should read between 13.6 and 14.3-volts. The ambient temperatures surrounding the voltage regulator should be between 50°F to 100°F while this test is being made.
- f. The voltage regulator heat sink, or case, is the ground connection for the electronic circuit. Therefore, if this unit is tested on the bench it is most important that a wire, No. 14, be connected between the regulator case and the alternator. If the regulator does not regulate between 13.6 and 14.4-volts, one of the following conditions may exist:
 1. Regulates, but out of specification. The regulator is out of calibration and must be replaced.
 2. The voltmeter continues to read battery voltage.
 - a. Poor or open connections within the wiring harness.
 - b. The regulator is open.

CHEROKEE ARROW III SERVICE MANUAL

3. Voltage continues to rise.
 - a. Regulator housing not grounded.
 - b. Regulator shorted, must be replaced.
- g. These are some of the things to look for in case of failure:
 1. Poor or loose connections.
 2. Poor ground on the regulator housing.
 3. Shorted alternator windings.
 4. A grounded yellow wire. (This will cause instantaneous failure.)
 5. Disconnecting the regulator while the circuit energized.
 6. Open circuit operation of the alternator. (The battery disconnected.)

11-45. OVERVOLTAGE RELAY. (Wico)

11-46. CHECK OVERVOLTAGE RELAY. The relay may be tested with the use of a good quality, accurate voltmeter, with a scale of at least 20-volts and a suitable power supply, with an output of at least 20-volts, or sufficient batteries with a voltage divider to regulate voltage. The test equipment may be connected by the following procedure:

- a. B+ is connected to BAT of the overvoltage control.
- b. B- is connected to the frame of the overvoltage control.
- c. Be sure both connections are secure and connected to a clean, bright surface.
- d. Connect the positive lead of the voltmeter to the BAT terminal of the overvoltage control.
- e. Connect the negative lead of the voltmeter to the frame of the overvoltage control.
- f. The overvoltage control is set to operate between 16.2-volts to 17.3-volts. By adjusting the voltage, an audible click may be heard when the relay operates.
- g. If the overvoltage control does not operate between 16.2 and 17.3-volts, it must be replaced.

11-47. STARTING MOTORS. (Prestolite)

WARNING

When servicing or inspecting vendor equipment installed in Piper aircraft, it is the user's responsibility to refer to the applicable vendor publication.

11-48. DESCRIPTION. On PA-28R-201 airplanes, the gear reduction starting motor consists of six major components: the commutator end head assembly, the armature, the frame and field assembly, the gear housing, the pinion housing, and the Bendix drive assembly. (Refer to Figure 11-37.) On PA-28R-201T, the starting motor consists of five major components: the commutator end head assembly, the brush set and plate assembly, the frame and field assembly, the armature, and the drive end head assembly. (Refer to Figure 11-38.)

11-49. OPERATION. When the starting circuit is energized, battery current is applied to the starting motor terminal. Current flows through the field coils creating a strong magnetic field. At the same time, current flows through the brushes to the commutator, through the armature windings to ground. The magnetic force created in the armature combined with that created in the field windings begins to turn the armature.

The following information concerning starting motors operation, refer to the PA-28R-201 only. The gear cut on the drive end of the armature shaft extends through the gear housing, where it is supported by a roller bearing. The gear mates with the teeth of the reduction gear that drives the Bendix shaft. The shaft is keyed to the reduction gear. The Bendix drive is held in position on the shaft by a spirol pin. The shaft is supported in the gear housing by a closed end roller bearing and in the pinion housing by a graphitized bronze bearing.

When the armature turns the reduction gear, the Bendix drive pinion meshes with the flywheel ring gear by inertia and action of the screw threads within the Bendix sleeve. A detent pin engages in a notch in the screw threads which prevents demeshing if the engine fails to start when the starting circuit is de-energized.

CHEROKEE ARROW III SERVICE MANUAL

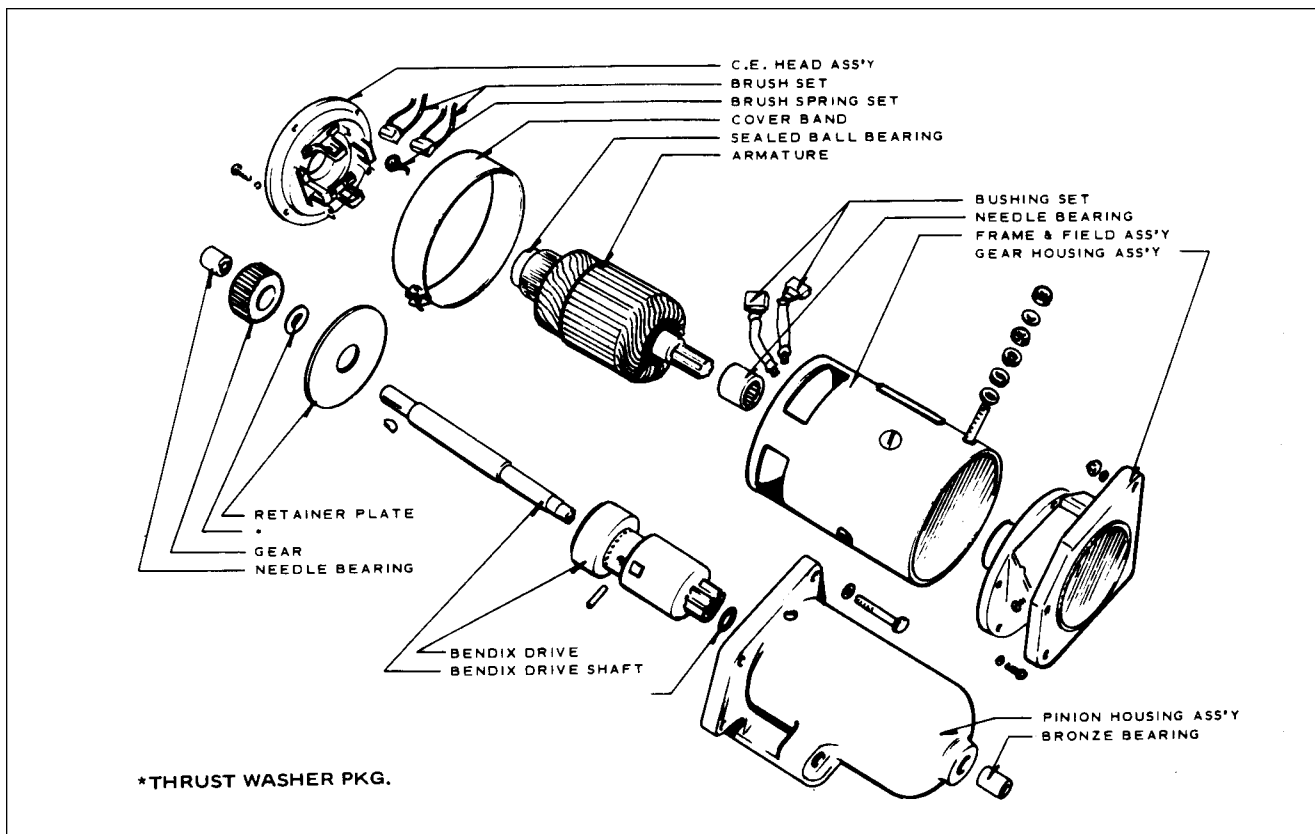

Figure 11-37. Exploded View of Gear Reduction Starting Motor (PA-28R-201)

When the engine reaches a predetermined speed, centrifugal action forces the detent pin out of the notch in the screw shaft and allows the pinion to demesh from the flywheel.

11-50. MAINTENANCE. The starting circuit should be inspected at regular intervals, the frequency of which should be determined by the amount of service and the conditions under which the aircraft is operated. It is recommended that such inspection be made at each 100 hours and include the following:

- a. The battery should be checked with a hydrometer to be sure it is fully charged and filled to the proper level with approved water. A load test should be made to determine battery condition. If dirt and corrosion have accumulated on the battery, it should be cleaned with a solution of baking soda and water. Be sure none of the solution enters the battery cells.
- b. The starting circuit wiring should be inspected to be sure that all connections are clean and tight and that the insulation is sound. A voltage loss test should be made to locate any high-resistance connections that would affect starting motor efficiency. This test is made with a low-reading voltmeter while cranking the engine or at approximately 100 amperes and the following limits should be used:
 1. Voltage loss from insulated battery post to starting motor terminal -0.3-volt maximum.
 2. Voltage loss from battery ground post to starter frame -0.1-volt maximum.

NOTE

If voltage loss is greater than the above limits, additional tests should be made over each part of the circuit to locate the high-resistance connections.

CHEROKEE ARROW III SERVICE MANUAL

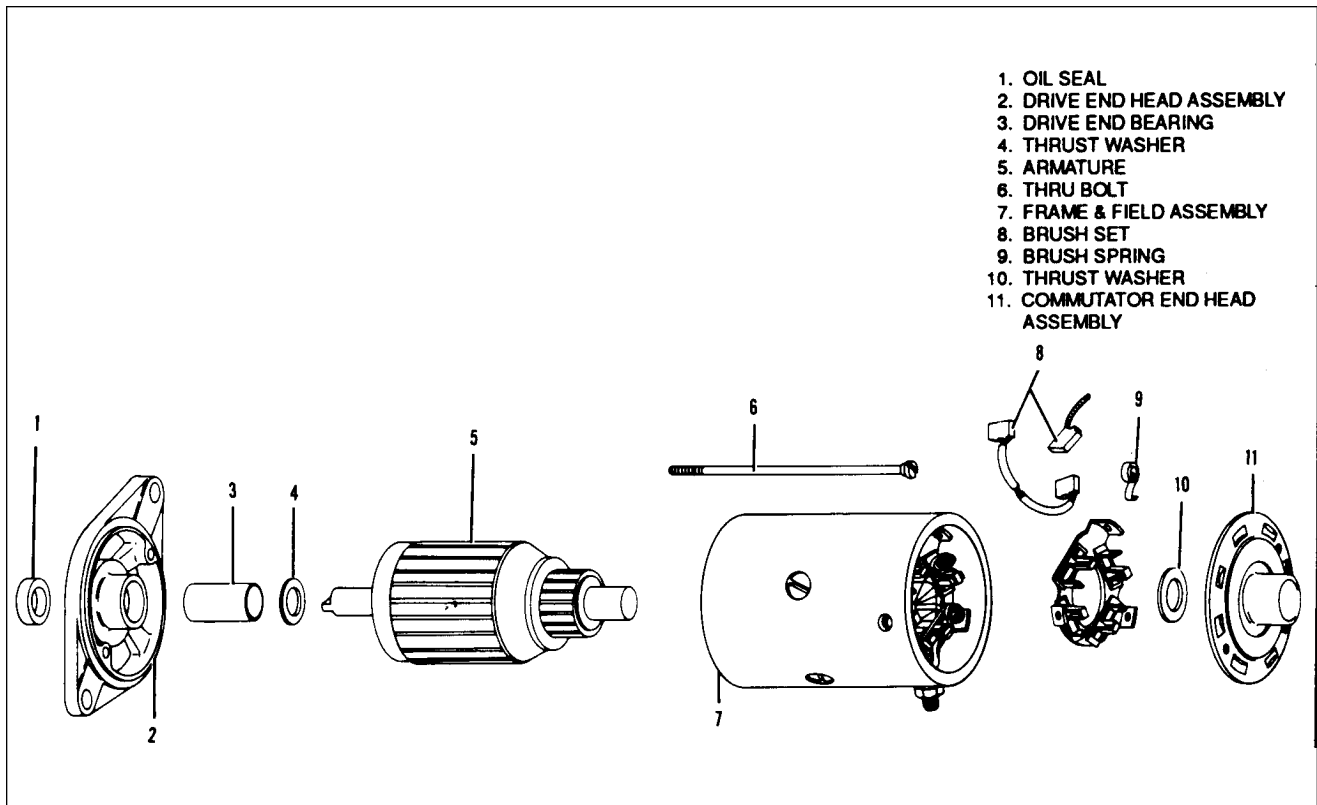

Figure 11-38. Exploded View of Starting Motor (PA-28R-201T)

- c. On PA-28R-201 airplanes, no lubrication is required on the starter motor except at the time of overhaul. Then lubricate the entire shaft under Bendix drive, fill grooves in armature shaft at drive end and pack gear box with 1.3 to 2.0 ounces of lithium soap base grease No. 1925 Molytex "O" or equivalent.
- On PA-28R-201T airplanes, no lubrication is required on the starting motor except at the time of overhaul. Soak new absorbent bronze bearings in SAE 20 oil before installation. Saturate the felt oiling pad in the commutator end head with SAE 20 oil. Allow excess oil to drain out before installing end head on motor. Put a light film of Lubriplate 777 on the drive end of the armature shaft before and after installing the drive end head.
- d. The starting motor should be operated for a few seconds with the ignition switch off. This is to determine that the starter engages properly and that it turns freely without binding or excessive noise. Start the engine two or three times to check the starter drive assembly.

NOTE

Refer to Bendix for service information concerning the starter drive mechanism.

11-51. OVERHAUL. If during the above inspection any indication of starting motor difficulty is noted, the starting motor should be removed from the engine for cleaning and repair.

11-52. REMOVAL. To remove the starting motor from the engine, first disconnect the ground cable from the battery post to prevent short circuiting. Disconnect the lead from the starting motor terminal, then take out the mounting bolts. The motor can then be lifted off and taken to the bench for overhaul.

CHEROKEE ARROW III SERVICE MANUAL

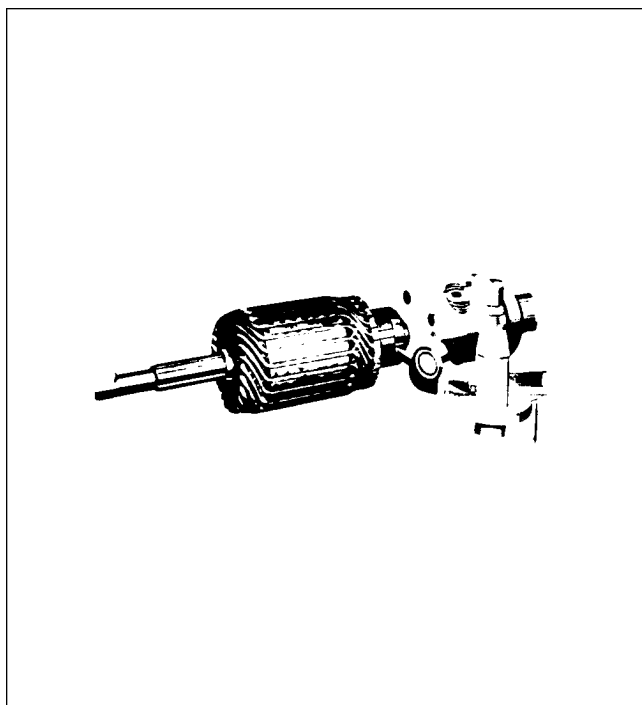

Figure 11-39. Turning Starting Motor Commutator

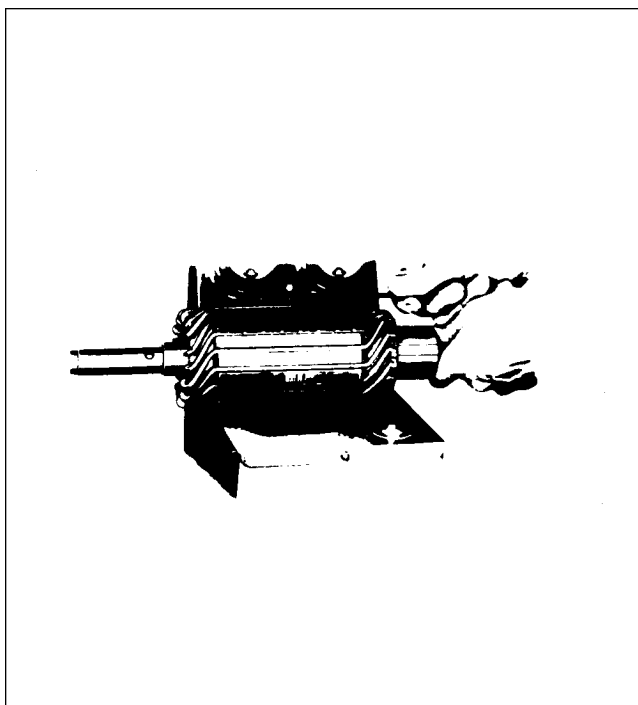

Figure 11-40. Testing Motor Armature for Short

11-53. DISASSEMBLY.

- a. Disassembly of starter motor used on PA-28R-201 airplanes is as follows:
 1. Remove the frame screws from the commutator end head and pull end head and armature from frame. Lift the brushes and lock in elevated position with brush springs. Use a puller to remove the end head from the armature. Use a special bearing puller to remove the sealed ball bearing from the armature shaft
 2. Remove the frame screws that secure the gear housing to the frame. Remove bolts and nuts holding the gear housing to the pinion housing and separate the two units. Pull Bendix shaft from pinion housing. Do not lose the steel spacer that is located on the pinion end of the shaft. Remove reduction gear, woodruff key and steel spacer from shaft.
 3. Turn the Bendix pinion until it locks in the extended position. Locate spirol pin and use a punch to remove. Slide drive assembly off the shaft. Do not attempt to disassemble the drive and do not dip it in cleaning solvent.
 4. To remove the roller bearings from the gear housing, use an arbor press and the correct bearing arbor. **DO NOT HAMMER OUT**. Each part should be cleaned and inspected for excessive wear or damage. Bearings should be checked for proper clearance and evidence of roughness or galling. Oil and dirt should be removed from insulation and the condition of the insulation checked.
- b. Disassembly of starter motor used on PA-28R-201T airplanes is as follows:
 1. Remove the safety wire and thru bolts from the commutator end and pull the end head from the frame.
 2. Pull the drive end head and armature from the frame and separate the drive end head from the armature.
 3. The drive end bearing may be removed by pressing out of the drive end head.
 4. Each part should be cleaned and inspected for excessive wear or damage. Bearing should be checked for proper clearance and evidence of roughness or galling. Oil and dirt should be removed from insulation and the condition of the insulation checked.

CHEROKEE ARROW III SERVICE MANUAL



Figure 11-41. Testing Motor Field for Grounds

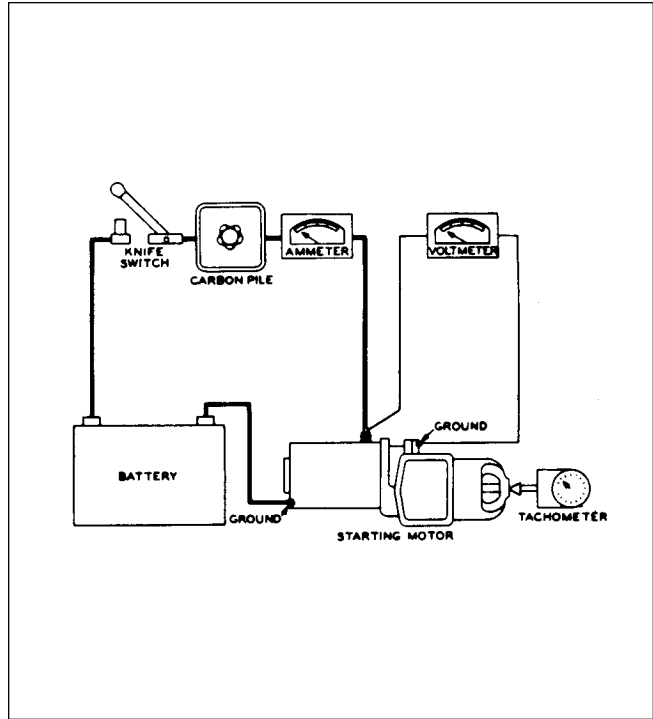

Figure 11-42. No-Load Test Hook-Up

11-54. **BRUSHES.** Check the brushes to see that they slide freely in their holders and make full contact on the commutator. If worn to half their original length or less, they should be replaced.

11-55. ARMATURE.

- Check the commutator for uneven wear, excessive glazing or evidence of excessive arcing. If only slightly dirty, glazed or discolored, the commutator can be cleaned with 00 to 000 sandpaper. If the commutator is rough or worn, it should be turned in a lathe. Refer to Figure 11-39. The armature shaft should be inspected for rough bearing surfaces and rough or damaged splines.
- To test the armature for grounds, a set of test probes connected in series with a 110-volt light should be used. Touch one probe to a commutator segment and the other to the armature core. If the test lamp lights, the armature is grounded and should be replaced.
- To test for shorted armature coils, a growler is used. (Refer to Figure 11-40.) The armature is placed on the growler and slowly rotated by hand while a steel strip is held over the core so that it passes over each armature core slot. If a coil is shorted, the steel strip will vibrate.
- A quick check for opens can be made by inspecting the trailing edge (in direction of rotation) of the commutator segments for excessive discoloration. This condition indicates an open circuit.

11-56. FIELD COILS.

- Check the field coils for grounds (refer to Figure 11-41) by placing one test probe on the frame and the other on the starter terminal. Be sure the brushes are not accidentally touching the frame. If the lamp lights, the fields are grounded. Repair or replace.
- Inspect all connections to make sure they are clean and tight and inspect insulation for deterioration.

11-57. BRUSH HOLDERS.

- To test brush holders, touch one test probe to the brush plate and the other to each brush holder.
- The test lamp should light when the grounded brush holders are touched and should not light when the insulated brush holders are touched.

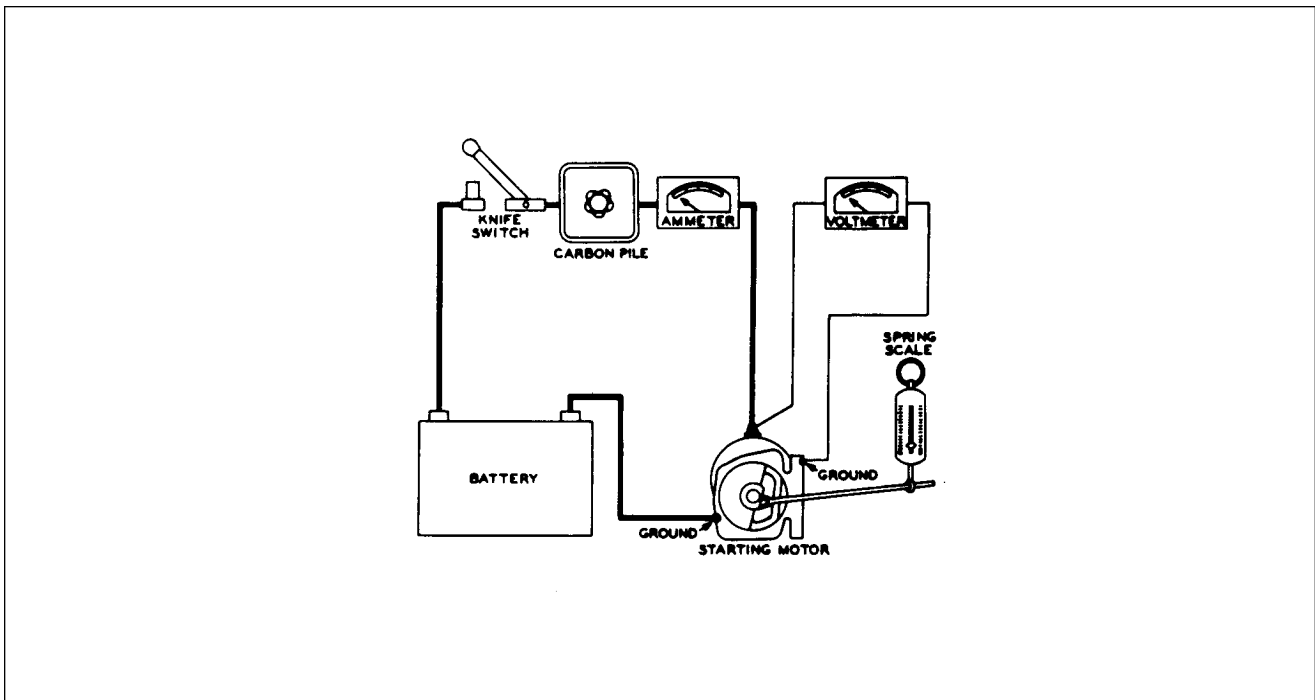

Figure 11-43. Stall - Torque Hook-Up

11-58. GEAR AND PINION HOUSING. (PA-28R-201) Inspect housings for cracks and bearings for excessive wear. Remove rust, paint or grease from mounting surfaces.

11-59. BENDIX DRIVE. (PA-28R-201) The Bendix drive should be wiped clean with a dry cloth. The pinion should turn smoothly in one direction and should lock in the other direction. Replace drive if it fails to check as above or if the pinion teeth are excessively worn or damaged.

11-60. ASSEMBLY.

- a. On PA-28R-201, when assembling the starter motor, always use an arbor press and the proper bearing arbor for installing graphitized bronze and roller bearings. The Bendix shaft should have a thin film of Lubriplate No. 777 or equivalent on the Bendix portion of the shaft. End play should be .005 to .050 of an inch.

On PA-28R-201T, when assembling the starting motor, always use a arbor press and the proper bearing arbor for installing graphitized bronze bearings. Soak new absorbent bronze bearings in SAE 20 oil before installation. Saturate the felt oiling pad in the commutator end head with SAE 20 oil. Allow excess oil to drain out before installing end head on motor. Put a light film of Lubriplate No. 777 on the drive end of the armature shaft before and after installing the drive end head.

- b. New brushes should be properly seated when installing by wrapping a strip of 00 sandpaper around the commutator (with the sanding side out) 1-1/4 to 1-1/2 times maximum. Drop brushes on sandpaper covered commutator and turn the armature slowly in the direction of rotation. Dust should be blown out of the motor after sanding.

NOTE

The spring tension is 32 to 40 ounces with new brushes. This tension is measured with the scale hooked under the brush spring near the brush and the reading is taken at right angles to the line of force exerted by the brush spring.

CHEROKEE ARROW III SERVICE MANUAL

- c. On PA-28R-201, check the position of the pinion to be sure the unit will mesh properly with the flywheel ring rear. See specifications of unit for correct dimensions. Refer to paragraph 11-63.

11-61. BENCH TESTS.

- a. After the starting motor is reassembled, it should be tested to see that the no-load current at a certain voltage is within specifications as given in paragraph 11-62. To make this test, connect as shown in Figure 11-42. If current is too high, check the bearing alignment and end play to make sure there is no binding or interference. Two or three sharp raps on the frame with a rawhide hammer will often help to align the bearings and free the armature.
- b. If no difficulty is indicated in the above test, a stall torque test may be made to see if the starting motor is producing its rated cranking power. Make test connections as shown in Figure 11-43.
- c. If torque and current are not within specifications, check the seating of the brushes and internal connections for high resistance. If these checks are made and found to be in good order, replace frame and field assembly and retest starter.

11-62. STARTING MOTOR CONTROL CIRCUIT.

- a. Inspect the control circuit wiring between the battery, solenoid and manual starting switches for breaks, poor connections and faulty insulation. Tighten all connections and make sure solenoid is firmly mounted and makes a good ground connection.
- b. Check the voltage loss across the switch contacts during normal starting. If loss is in excess of 0.2 volts per 100 amperes, the solenoid should be replaced.
- c. If solenoid fails to operate when the manual starting switch is turned on or if it fails to release when the manual starting switch is released, it should be removed and tested to specifications. If either opening or closing voltages are not to specifications, replace the solenoid.

11-63. STARTING MOTOR SERVICE TEST SPECIFICATIONS. Prestolite specifications for standard equipment 12-volt starting motors installed on both model aircraft are as shown in Table XI-III.

11-64. BATTERY.

11-65. SERVICING BATTERY. Access to the battery is through the aft side of the baggage compartment. It is enclosed in a thermoplastic box with a vent system and a drain. The vents allow fresh air to enter the box and draw off fumes that may accumulate due to the charging process of the battery. The drain is clamped off and should be opened occasionally to drain any accumulation of liquid or during cleaning of the box. The battery should be checked for fluid level but must not be filled above the baffle plates. A hydrometer check should be performed to determine the percent of charge in the battery. All connections must be clean and tight.

11-66. REMOVAL OF BATTERY.

- a. Remove the access panel to the aft section of the fuselage.
- b. Remove battery box cover.
- c. Disconnect the battery cables.

NOTE

Always remove the ground cable first and install last to prevent accidental short circuiting or arcing.

- d. Lift the battery from the box.

CHEROKEE ARROW III SERVICE MANUAL

TABLE XI-III. STARTING MOTOR SERVICE TEST SPECIFICATIONS

<u>Aircraft Model</u> Motor Model	<u>PA-28R-201</u> MZ4206	<u>PA-28R-201T</u> MCL-6501
Min. Brush Tension Max. Brush Tension	32 oz. 40 oz.	32 oz. 40 oz.
No-Load Test Volt Max. Amps Min. RPM	(77°F) 10 75 2000	(75°F) 6 65 4900
Stall Torque Amps Min. Torque, Ft.-Lbs. Approx. Volts	560 38.0 4.0	410 8 2.0
Pinion Position* Drive at Rest Drive Extended	1.748 in. to 1.855 in. 2.388 in. to 2.495 in.	
*This dimension is measured from the centerline of the mounting hole nearest the drive end head to the edge of the pinion.		

11-67. INSTALLATION OF BATTERY.

- a. Ascertain that the battery and battery box have been cleaned and are free of acid.
- b. Install the battery in box.
- c. Connect the positive lead to the positive battery terminal and secure.
- d. Connect the ground cable to the negative battery terminal and secure.
- e. Install the battery box cover and secure with wing nuts.
- f. Install access panel.

11-68. CHARGING BATTERY. If the battery is not up to normal charge, remove the battery and recharge starting with a charging rate of 4-amps and finishing with 2-amps. A fast charge is not recommended.

CHEROKEE ARROW III SERVICE MANUAL

TABLE XI-IV. HYDROMETER READING AND BATTERY CHARGE PERCENT

Hydrometer Reading	Percent of Charge
1280	100
1250	75
1220	50
1190	25
1160	Very little useful capacity
1130 or below	discharged

11-69. BATTERY BOX CORROSION PREVENTION. The battery should be checked for spilled electrolyte or corrosion at least each 50 hour inspection or at least every 30 days, whichever comes first. Should this be found in the box, on the terminals or around the battery, the battery should be removed and both the box and battery cleaned by the following procedure:

- a. Remove the box drain cap from the underside of the fuselage and drain off any electrolyte that may have overflowed into the box.
- b. Clean the battery and the box. Corrosion effects may be neutralized by applying a solution of baking soda and water mixed to a consistency of thin cream. The application of this mixture should be applied until all bubbling action has ceased.

CAUTION

Do not allow soda solution to enter battery.

- c. Rinse the battery and box with clean water and dry.
- d. Place the cap over the battery box drain.
- e. Reinstall the battery.

11-70. STARTING THROUGH EXTERNAL POWER RECEPTACLE AND AIRPLANE'S BATTERY NEARLY DEPLETED.

NOTE

Should the hydrometer reading indicate less than 1190, the battery should be removed and recharged or replaced.

- a. When using a 12-volt battery for external power starting and the airplane's battery is nearly depleted, the following procedure should be used:
 1. Disconnect the airplane's battery at the negative terminal to prevent excessive loading of the external starting battery.
 2. Check that all of the airplane's electrical equipment is turned OFF.
 3. Connect the external battery to the external power receptacle; turn master switch ON and start engine using normal starting procedure.
 4. Turn master switch OFF; remove external battery and then reconnect the battery at the negative terminal.

5. Turn master switch ON and check ammeter for battery charging current.
- b. When starting with a power cart and the airplane's battery is nearly depleted, the procedure in step a. need not be followed. The capacity of a power cart is sufficient to start an aircraft with a low battery. If a 6-volt battery is available, it can be connected in series with the 12-volt external battery to supply 18-volts for starting. In this case, use the same starting procedure as used with a power cart.

CAUTION

If aircraft battery is weak, charging current will be high. Do not take off until charging current falls below 20 amps.

Never use a 12 or 24-volt battery in place of a 6-volt battery since electrical damage may result.

11-71. LANDING AND TAXI LIGHT.

11-72. DESCRIPTION. The landing and taxi light consists of one light bulb. It is 100 watts and located in the nose cowl. The light is controlled by a switch to a 10 amp circuit breaker.

11-73. REMOVAL.

- a. Remove the retaining bracket from the lamp.
- b. Pull lamp out and remove the two electrical leads from the back of the lamp. Lamp is now free.

NOTE

Make note of the placement of the wires to facilitate reinstallation.

11-74. INSTALLATION.

- a. Replace electrical leads and secure with appropriate screws.
- b. Insert lamp into position fit retaining bracket and secure with appropriate hardware.

11-75. NAVIGATION LIGHTS.

11-76. DESCRIPTION. There are three navigation lights; one on each wing tip and one on the tail. The navigation lights are controlled by a single switch and a 10 amp circuit breaker.

11-77. REMOVAL OF WING NAVIGATION LIGHTS.

- a. Remove screw securing the lens retainer.
- b. Remove the lens and bulb.

NOTE

To remove the complete lamp assembly, the wing tip must be removed.

11-78. INSTALLATION OF WING NAVIGATION LIGHTS.

- a. Install bulb, lens and lens retainer.
- b. Secure with the appropriate screws.

11-79. REMOVAL OF TAIL NAVIGATION LIGHT.

- a. Remove the two screws securing the lens and lens retainer.
- b. Remove the bulb.

NOTE

To remove the complete tail light assembly, unsolder the electrical lead from the base of the light assembly and disconnect the remaining electrical lead at the connector.

11-80. INSTALLATION OF TAIL NAVIGATION LIGHT.

- a. Install bulb and lens in light assembly.
- b. Place light assembly in position on tail and secure with screws previously removed.

11-81. ANTI-COLLISION (STROBE)

11-82. DESCRIPTION. The lights are located on each wing tip in the same assembly with navigation lights on the fin tip. They are rated to flash at approximately 50 times a minute.

11-83. REMOVAL OF WING TIP STROBE LIGHT.

- a. Remove the screw securing the navigation light cover and remove cover.
- b. Remove the three screws securing navigation light bracket assembly and pull out.
- c. Remove the strobe lamp by cutting the wires on the lamp beneath the mounting bracket.
- d. Remove the defective lamp.
- e. Remove and discard the plug with the cut wires from its electrical socket.

11-84. INSTALLATION OF WING TIP STROBE LIGHT.

- a. Route the wires from the new lamp down through the hole in the navigation light bracket.
- b. Insert the wire terminals in the plastic plug supplied with the new lamp. Wire according to the schematic diagram located in the back of this section and also see Figure 11-44.
- c. Position strobe lamp on navigation light bracket.
- d. Secure navigation light assembly and bracket with appropriate screws.
- e. Install navigation light cover and secure with appropriate screw.

11-85. REMOVAL OF STROBE POWER SUPPLY. The strobe power supply is in the aft section of the fuselage.

- a. Remove access panel to the aft section of the fuselage in the rear baggage compartment to gain access to power supply.
- b. To remove power supply, disconnect the two electrical plugs.
- c. Disconnect the two other electrical leads.
- d. Remove the four screws securing power supply to the fuselage. Power supply can now be removed.

11-86. INSTALLATION OF STROBE POWER SUPPLY. (Refer to Figure 11-44.)

- a. Position the power supply in place and secure with the four screws previously removed.
- b. Reconnect the electrical leads in their proper place.
- c. Reconnect the electrical plugs previously removed in their proper place.
- d. Replace access panel in rear baggage compartment.

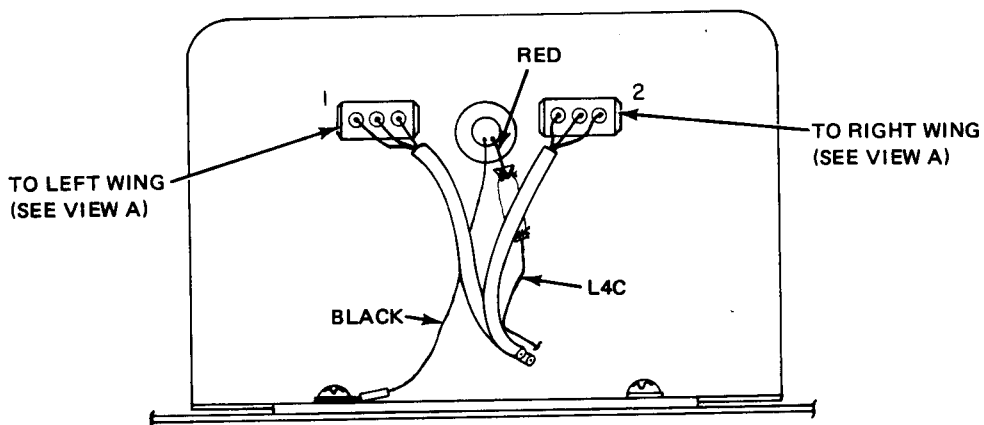
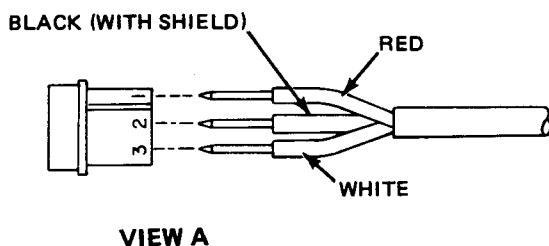
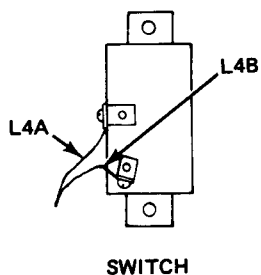

28R-201 S/N's up to 7837259 inclusive
 28R-201T S/N's up to 7803305 inclusive

Figure 11-44. Strobe Light Connections (Earlier Models)

**STROBE
INSTALLATION
SWITCH**

**SWITCH FOR STROBE
WITH BEACON INSTALLATION**

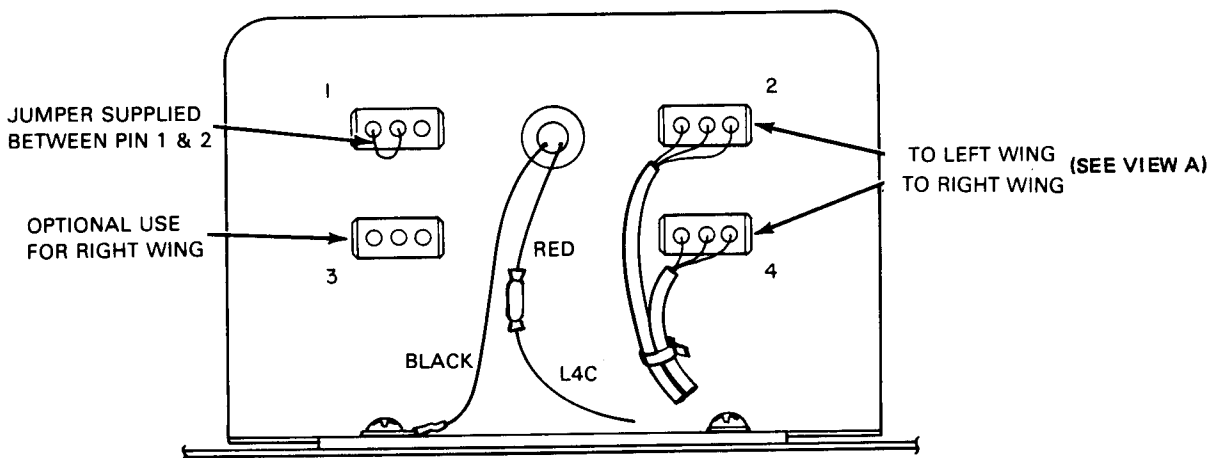
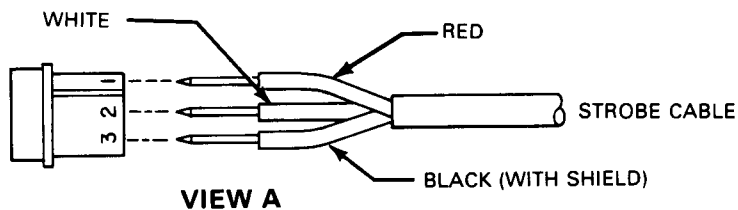
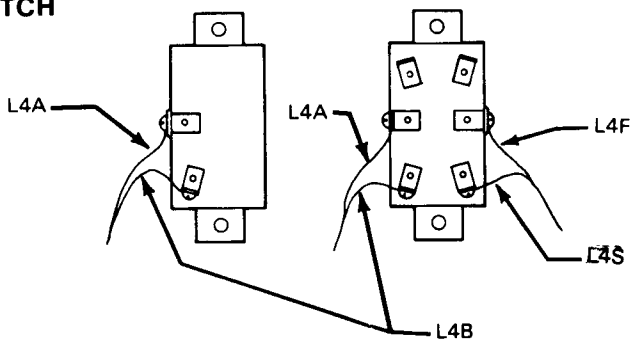

**28R-201 S/N's 7837260 and up
28R-201T S/N's 7803306 and up**

Figure 11-44a. Strobe Light Connections (Later Models)

11-87. TROUBLESHOOTING PROCEDURE. The strobe light functions as a condenser discharge system. A condenser in the power supply is charged to approximately 450 volts dc discharged across the Xenon flash tube at intervals of approximately 50 flashes per minute. The condenser is parallel across the Xenon flash tube which is designated to hold off the 450 volts dc applied until the flash tube is triggered by an external pulse. This pulse is generated by a solid state timing circuit in the power supply.

When troubleshooting the strobe light system, it must first be determined if the trouble is in the flash tube or the power supply. Replacement of the flash tube will confirm if the tube is defective. A normally operating power supply will emit an audible tone of 1 to 1.5 kHz. If there is no sound emitted, check the system according to the following instructions. When troubleshooting the system, utilize the appropriate schematic at the back of this section.

- a. Ascertain the input voltage at the power supply is 14 volts.

CAUTION

When disconnecting and connecting the power supply input connections, do not get the connections reversed. Reversed polarity of the input voltage for just an instant will permanently damage the power supply. The reversed polarity destroys a protective diode in the power supply, causing self-destruction from overheating of the power supply. This damage is sometimes not immediately apparent, but will cause failure of the system in time.

- b. Check for malfunction in interconnecting cables.
 1. Ascertain Pins 1 and 3 of interconnecting cable are not reversed.
 2. Using an ohmmeter, check continuity between Pins 1 and 3 of interconnecting cable. If a reading is obtained on the meter, the cable is shorted and should be replaced.

NOTE

A short of the type described in Steps 1 and 2 will not cause permanent damage to the power supply, but the system will be inoperative if such a short exists. Avoid any connection between Pins 1 and 3 of the interconnecting cable as this will discharge the condenser in the power supply and destroy the trigger circuits.

CAUTION

When disconnecting the power supply, allow five minutes of bleed down time prior to handling the unit.

- c. Check interconnecting cables for shorts.
 1. Disconnect the output cables from the power supply outlets.
 2. The following continuity check can be made with an ohmmeter.
 3. Check for continuity between the connectors of each interconnecting cable by checking from Pin 1 to Pin 1, Pin 2 to Pin 2, and Pin 3 to Pin 3. When making these checks if no continuity exists, the cable is broken and should be replaced.
 4. Check continuity between Pins 1 and 2, 1 and 3, 2 and 3 of the interconnecting cable. If continuity exists between any of these connections, the cable is shorted and should be replaced.

CHEROKEE ARROW III SERVICE MANUAL

11-88. INSTRUMENT AND PANEL LIGHTS. The instrument and panel lights are broken up into three groups; Lower Panel Light, Upper Panel Lights, and Compass Light. The instrument lights are controlled by a 5 amp circuit breaker through a transistorized dimmer. A second dimmer control is connected to a variable resistor which controls the light intensity for all the avionic equipment. The dimmer controls are located in the middle of the instrument panel just above the pedestal. It may be necessary to gain access to the Dimmer Control Assembly; if so, follow the instructions given below.

11-89. REMOVAL OF DIMMER CONTROL ASSEMBLY.

- a. Access to the Dimmer Control Assembly is from beneath the instrument panel.
- b. Disconnect the electrical connection from the assembly.
- c. Remove the two screws securing the assembly to the instrument panel.
- d. Remove assembly from the airplane.

11-90. INSTALLATION OF DIMMER CONTROL ASSEMBLY.

- a. Position the assembly in the instrument panel with the control knobs inserted into their appropriate slots.
- b. Secure the assembly to the instrument panel with the two screws previously removed.
- c. Connect the electrical connection to the assembly.
- d. Check operation of Dimmer Control Assembly.

11-91. ANNUNCIATOR PANEL.

11-92. DESCRIPTION. The annunciator panel is a small cluster of lights which warn of malfunctions in the various circuits or systems. A malfunction is identified by the illumination of an individual warning light. There are three warning lights on the PA-28R-201 models and four warning lights on the PA-28R-201T models. The PA-28R-201T also has a smaller light which indicates when the auxiliary fuel pump is on. Power is supplied from the bus bar through a 5 amp fuse located behind the switch panel.

The VAC warning light is controlled by a vacuum sensor switch located at the firewall and is attached to the vacuum regulator. The sensor switch will activate when the differential pressure is below 3.5 in. Hg.

The OIL warning light is controlled by an oil pressure sensor switch incorporated in the oil line to the oil pressure gauge and is located at the firewall. The sensor switch will activate when the oil pressure is below 35 psi on PA-28R-201 or 30 psi on PA-28R-201T models.

The ALT warning light is illuminated by current flowing from the bus bar to the alternator circuit. This condition exists when the alternator is not operating properly and the output is zero. During normal operation, the alternator warning circuit is also supplied with power from the top diode terminal. This current flows through a 5 amp fuse, located near the diode heat sink, to the resistor and diode creating a no-flow condition which does not allow the warning light to light.

The OVER BST warning light used on PA-28R-201T is activated whenever the engine manifold pressure exceeds $40.75 \pm .15$ inches of mercury. The manifold pressure sensor is incorporated in the manifold pressure gauge.

A press-to-test button is used to check the operation of the lights when the engine is running. The lights will work when the engine is not running with the master switch turned on. The auxiliary fuel on light is not tested with the press-to-test button.

11-93. REMOVAL OF OIL PRESSURE SENSOR. Access to the sensor unit is gained by reaching up under the instrument panel. Removal is accomplished by the following.

- a. Disconnect the two electrical leads.
- b. Unscrew the sensor unit from the bulkhead fitting.
- c. Catch spillage and cover hole to prevent foreign matter from entering oil line.

11-94. INSTALLATION OF OIL PRESSURE SENSOR.

- a. Seal sensor unit pipe threads with thread sealant tape (3M Teflon No. 48 x 1/4").
- b. Screw the sensor unit into the bulkhead fitting.
- c. Reconnect the two electrical leads.
- d. Perform operational check.

11-95. REMOVAL OF VACUUM SENSOR. Access to the sensor unit is gained by reaching up under the instrument panel to the vacuum regulator. Removal is accomplished by the following:

- a. Disconnect the two electrical leads.
- b. Unscrew the sensor unit from the vacuum regulator.
- c. Cover hole to prevent foreign matter from entering regulator.

11-96. INSTALLATION OF VACUUM SENSOR.

- a. Screw sensor unit into vacuum regulator.
- b. Reconnect the two electrical leads.
- c. Perform operational check.

NOTE

In the past, aluminum cable has been used in the wiring of the battery circuit: battery to ground, battery to master relay, master relay to starter solenoid, starter solenoid to starter, and the ground wire to airframe. If during inspection, a fault is found with any aluminum cable or wiring, Piper considers it mandatory that it be replaced with copper wire with suitable terminals.

11-97. IGNITION SWITCH. (Refer to Figure 11-44b.)

11-98. REMOVAL OF IGNITION SWITCH. Access to the ignition switch is gained by reaching up under the instrument panel.

- a. Ensure the ignition switch is in the OFF position.
- b. Disconnect the power lead from the battery.
- c. Remove the retaining nut from the ignition switch on the front side of the instrument panel.
- d. Pull the switch from the back side of the instrument panel and remove wires.

11-99. INSTALLATION OF IGNITION SWITCH. (Refer to Figure 11-44b.)

- a. Using the illustration as a reference, attach the wires to the ignition switch.
- b. Before proceeding, check for proper operation of the ignition switch as follows:
 1. Remove the P-lead from the right magneto.
 2. Attach the P-lead of the right magneto to an ohmmeter and to airframe ground.
 3. With the switch in the OFF, L or START positions, the ohmmeter should indicate a closed circuit.
 4. With the switch in the R or BOTH position, the ohmmeter should indicate an open circuit.
 5. Reconnect the P-lead to the magneto.
- c. Position the ignition switch in the instrument panel and secure with the retaining nut.
- d. Reconnect the power lead to the battery.

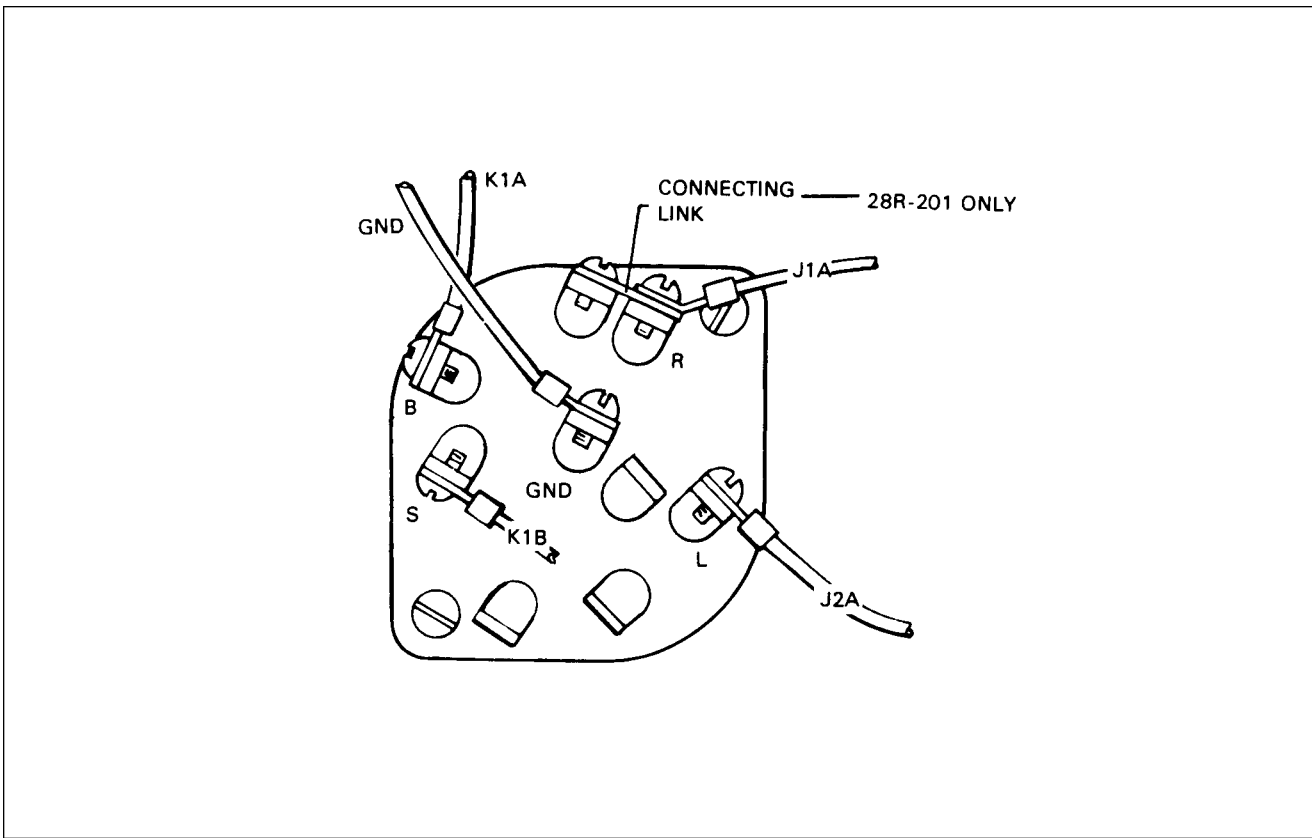

Figure 11-44b. Ignition Switch

CHEROKEE ARROW III SERVICE MANUAL

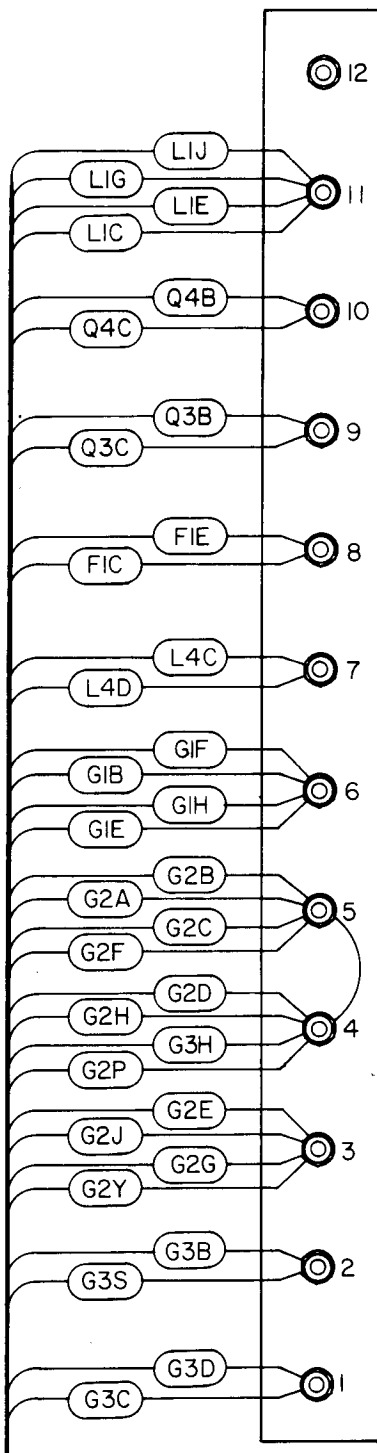

Figure 11-45. Terminal Block

CHEROKEE ARROW III SERVICE MANUAL

TABLE XI-V. ELECTRICAL SYSTEM TROUBLESHOOTING

Trouble	Cause	Remedy
ALTERNATOR		
<p>Zero output indicated on ammeter regardless of rpm (refer to alternator system test procedure).</p>	<p>Open field circuit.</p>	<p>With master switch turned on, check for battery voltage from airplane's main buss through entire field circuit to alternator field terminal. Measure voltage from ground (-) to the following points (+) in sequence: buss bar, output circuit diodes, field circuit breaker (SA), field terminals of master switch, voltage regulator and alternator field terminal.</p> <p>Interruption of voltage through any of these points isolates the faulty components or wire which must be placed. (See wiring schematic.)</p>
	<p>Open output circuit.</p>	<p>With master switch turned on, check for battery voltage from airplane's main buss through entire output circuit to alternator battery post. Measure voltage from ground (-) to the following points (+) in sequence: buss bar, output diodes ammeter, and alternator battery post.</p>

CHEROKEE ARROW III SERVICE MANUAL

TABLE XI-V. ELECTRICAL SYSTEM TROUBLESHOOTING (cont)

Trouble	Cause	Remedy
ALTERNATOR (cont)		
<p>Zero output indicated on ammeter regardless of rpm (refer to alternator system test procedure). (cont)</p>	<p>Open field winding in alternator.</p>	<p>Interruption of voltage through any of these points isolates the faulty component or wire which must be replaced. (See wiring schematic.)</p> <p>Disconnect field terminal of alternator from field wiring and check for continuity from field terminal to ground with ohmmeter (20 - 100 ohms) depending on brush contact resistance. (Pull propeller slowly by hand turning alternator rotor through 360° of travel.)</p> <p style="text-align: center;">CAUTION</p> <p>Turn magneto switch to off before turning prop.</p> <p>If resistance is high, check brushes for spring tension and excessive wear and replace if necessary. If brushes are okay and field reads open, replace alternator.</p>

CHEROKEE ARROW III SERVICE MANUAL

TABLE XI-V. ELECTRICAL SYSTEM TROUBLESHOOTING (cont)

Trouble	Cause	Remedy
ALTERNATOR (cont)		
<p>Output indicated on ammeter does not meet minimum values specified in alternator system test procedure. (cont)</p>	<p>Open rectifier.</p>	<p>If any of the six rectifiers pressed into the rear bell housing of the alternator open up internally, it will result in a definite limitation on the current that can be drawn from the alternator. After having checked the previous causes of low output, it can be assumed that a faulty rectifier exists.</p> <p>See paragraphs titled Testing of Rectifiers or Inspection and Testing of Components.</p>
<p>Field circuit breaker trips.</p>	<p>Short circuit in field circuit.</p>	<p>Disconnect field wiring at terminal of alternator. Turn on master switch. If breaker continues to trip, proceed to disconnect each leg of field circuit, working from the alternator towards the circuit breaker until breaker can be reset and will hold. Replace component or wire which was isolated as defective. (See wiring schematic.)</p>

CHEROKEE ARROW III SERVICE MANUAL

TABLE XI-V. ELECTRICAL SYSTEM TROUBLESHOOTING (cont)

Trouble	Cause	Remedy
ALTERNATOR (cont)		
<p>Field circuit breaker trips. (cont)</p>	<p>Short circuit in field winding of alternator.</p>	<p>Disconnect field wiring at terminal of alternator. Turn on master switch. Reset breaker and if breaker fails to retrip, this isolates short circuit to field of alternator itself. Check brush holders for shorting against frame. If there are no obvious signs of a physical short circuit at field terminal or brush holder, replace alternator. (Note: Intermittent short circuit.) Internal short circuiting of the field can occur at various positions of the rotor, therefore, reconnect field, reset breaker, pull propeller slowly by hand turning alternator rotor through 360° of travel. Observe circuit breaker for signs of tripping.</p> <p style="text-align: center;">CAUTION</p> <p>Turn magneto switch to off before turning propeller.</p>

CHEROKEE ARROW III SERVICE MANUAL

TABLE XI-V. ELECTRICAL SYSTEM TROUBLESHOOTING (cont)

Trouble	Cause	Remedy
ALTERNATOR (cont)		
<p>Output circuit defective.</p>	<p>Short circuit in output circuit.</p> <p>Battery installed with reversed polarity.</p> <p>Battery charged backwards.</p>	<p>Disconnect wiring at battery post of alternator. Turn on master switch. Disconnect each leg of output circuit, working from the alternator towards the bus bar. Replace component or wire which was isolated as defective. (See schematic.)</p> <p>Remove battery and reinstall with correct polarity.</p> <p>Remove battery. Connect load such as landing light lamp or similar load and discharge battery. Recharge with correct polarity and test each cell for signs of damage due to reversed charging.</p> <p style="text-align: center;">NOTE</p> <p>This type of condition can only occur in a case where a discharged battery has been removed from the airplane and put on a charger with the polarity reversed. This reversal in polarity cannot occur in the airplane due to any fault in the alternator system.</p>

CHEROKEE ARROW III SERVICE MANUAL

TABLE XI-V. ELECTRICAL SYSTEM TROUBLESHOOTING (cont)

Trouble	Cause	Remedy
ALTERNATOR (cont)		
<p>Excessive ammeter fluctuation.</p>	<p>Excessive resistance in field circuit.</p> <p>High field circuit resistance.</p> <p>Defective voltage regulator.</p>	<p>Check all connections and wire terminals in field circuit for deterioration such as loose binding posts, broken wire strands at terminals, etc. Tighten all connections and replace faulty terminals.</p> <p>If problem persists, jump across terminals of the following components one at a time until the faulty unit is isolated.</p> <ol style="list-style-type: none"> a. Field 5 amp (alternator) circuit protector. b. Alternator half of master switch. c. Overvoltage relay. <p>Replace voltage regulator.</p>

CHEROKEE ARROW III SERVICE MANUAL

TABLE XI-V. ELECTRICAL SYSTEM TROUBLESHOOTING (cont)

Trouble	Cause	Remedy
STARTER		
<p>Motor fails to operate.</p>	<p>Low battery charge.</p> <p>Defective or improper wiring or loose connections.</p> <p>Defective starter solenoid or control switch.</p> <p>Binding, worn, or improperly seated brush or brushes with excessive side play.</p>	<p>Check and recharge if necessary.</p> <p>Refer to electrical wiring diagram and check all wiring.</p> <p>Replace faulty unit.</p> <p>Brushes should be a free fit in the brush boxes without excessive side play. Binding brushes and brush boxes should be wiped clean with a gasoline (undoped) moistened cloth. A new brush should be run in until at least 50 percent seated; however, if facilities are not available for running in brushes, then the brush should be properly seated by inserting a strip of number 000 sandpaper between the brush and commutator, with the sanded side next to the brush. Pull sandpaper in the direction of rotation, being careful to keep it in the same contour as the commutator.</p>

CHEROKEE ARROW III SERVICE MANUAL

TABLE XI-V. ELECTRICAL SYSTEM TROUBLESHOOTING (cont)

Trouble	Cause	Remedy
STARTER (cont)		
<p>Motor fails to operate. (cont)</p>	<p>Binding, worn, or improperly seated brush, or brushes with excessive side play. (cont)</p> <p>Dirty commutator.</p> <p>Shorted, grounded, or open armature.</p> <p>Grounded or open field circuit.</p>	<p style="text-align: center;">CAUTION</p> <p>Do not use coarse sandpaper or emery cloth. After seating, clean thoroughly to remove all sand and metal particles to prevent excessive wear. Keep motor bearing free from sand or metal particles.</p> <p>If commutator is rough or dirty, smooth and polish with number 0000 sandpaper. If too rough and pitted, remove and turn down. Blow out all particles.</p> <p>Remove and replace with an armature known to be in good condition.</p> <p>Test, repair if possible or replace with a new part.</p>
<p>Low motor and cranking speed.</p>	<p>Worn, rough, or improperly lubricated motor or starter gearing.</p> <p>Same electrical causes as listed under "Motor Fails to Operate."</p>	<p>Disassemble, clean, inspect, and relubricate, replace ball bearings if worn.</p> <p>Same remedies listed for these troubles.</p>

CHEROKEE ARROW III SERVICE MANUAL

TABLE XI-V. ELECTRICAL SYSTEM TROUBLESHOOTING (cont)

Trouble	Cause	Remedy
STARTER (cont)		
Excessive arcing of motor brushes.	<p>Binding, worn, or improperly seated brush or brushes with excessive side play.</p> <p>Dirty commutator, rough, pitted, or scored.</p>	<p>See information above dealing with this trouble.</p> <p>Clean as outlined above.</p>
Excessive wear and arcing of motor brushes.	<p>Rough or scored commutator.</p> <p>Armature assembly not concentric.</p>	<p>Remove and turn commutator down on a lathe.</p> <p>Reface commutator.</p>
BATTERY		
Discharged battery.	<p>Battery worn out.</p> <p>Low electrical system voltage.</p> <p>Standing too long.</p> <p>Equipment left on accidentally.</p> <p>Impurities in electrolyte.</p> <p>Short circuit (ground) in wiring.</p> <p>Broken cell partitions.</p>	<p>Replace battery.</p> <p>Check voltage regulator voltage.</p> <p>Remove and recharge battery if left in unused airplane three weeks or more.</p> <p>Remove and recharge.</p> <p>Replace.</p> <p>Check wiring.</p> <p>Replace.</p>

CHEROKEE ARROW III SERVICE MANUAL

TABLE XI-V. ELECTRICAL SYSTEM TROUBLESHOOTING (cont)

Trouble	Cause	Remedy
BATTERY (cont)		
Battery life is short.	Overcharge due to level of electrolyte being below top of plates. Sulfation due to disuse. Impurities in electrolyte. Low charging rate.	Maintain electrolyte. Replace. Replace battery. Check voltage regulator voltage.
Cracked cell jars.	Hold-down bracket loose. Frozen battery.	Replace battery and tighten. Replace.
Compound on top of battery melts.	Charging rate too high.	Reduce charging rate. Check voltage regulator voltage.
Electrolyte runs out of vent plugs.	Too much water added to battery and charging rate too high	Drain and keep at proper level and check voltage regulator voltage.
Excessive corrosion inside container.	Spillage from over-filling. Vent lines leaking or clogged. Charging rate too high.	Use care in adding water. Repair or clean. Check voltage regulator voltage.

CHEROKEE ARROW III SERVICE MANUAL

TABLE XI-V. ELECTRICAL SYSTEM TROUBLESHOOTING (cont)

Trouble	Cause	Remedy
BATTERY (cont)		
Battery freezes.	Discharged battery. Water added and battery not charged immediately.	Replace. Always recharge battery for 1/2 hour following addition of water in freezing weather.
Leaking battery jar.	Frozen.	Replace.
Battery polarity reversed.	Connected backwards on airplane or charger.	Battery should be slowly discharged completely and then charged correctly and tested.
Battery consumes excessive water.	Charging rate too high (if in all cells). Cracked jar (one cell only).	Correct charging rate. Replace battery.
ANNUNCIATOR PANEL		
All warning lights fail to operate.	Blown fuse.	Replace the 5 amp fuse behind instrument panel.
	No current from bus.	Check all wire segments, connections, and the receptacle at the left side of the annunciator panel.
All the warning lights fail to extinguish after engine is running.	Test switch grounded out.	Check terminals and replace switch if necessary.

CHEROKEE ARROW III SERVICE MANUAL

TABLE XI-V. ELECTRICAL SYSTEM TROUBLESHOOTING (cont)

Trouble	Cause	Remedy
ANNUNCIATOR PANEL (cont)		
OIL warning light fails to operate.	Bulb burned out.	Replace.
	No current to sensor.	Check all wire segments and connections.
	Sensor activates at a to low setting.	Replace.
	Defective sensor.	Replace.
OIL warning light fails to extinguish.	Sensor activates at a too high setting.	Replace.
	Sensor terminals bridged.	Remove material between terminals.
	Defective sensor.	Replace.
OVER BOOST warning fails to operate.	Bulb burned out.	Replace.
	Circuit in manifold pressure gauge defective.	Replace gauge.
OVER BOOST warning fails to extinguish.	Press to test switch shorted to ground.	Replace switch.
	Circuit in manifold pressure gauge defective.	Replace gauge.
VAC warning light fails to operate.	Bulb burned out.	Replace.
	No current to sensor.	Check all wire segments and connections.

CHEROKEE ARROW III SERVICE MANUAL

TABLE XI-V. ELECTRICAL SYSTEM TROUBLESHOOTING (cont)

Trouble	Cause	Remedy
ANNUNCIATOR PANEL (cont)		
VAC warning light fails to operate. (cont)	Sensor activates at a too low setting.	Replace.
	Defective sensor.	Replace.
VAC warning light fails to extinguish.	Sensor activates at a too high setting.	Replace.
	Sensor terminals bridged.	Remove material between terminals.
	Defective sensor.	Replace.
ALT warning light fails to operate.	Bulb burned out.	Replace.
	No current from bus to resistor.	Check all wire segments and connections.
ALT warning light fails to extinguish.	Blown fuse.	Replace 5 amp fuse near the diode heat sink.
	No current from the fuse to the resistor.	Check all wire segments and connections.
Test switch fails to activate warning lights.	Bad switch or connections.	Check wires and replace switch if necessary.

CHEROKEE ARROW III SERVICE MANUAL

TABLE XI-VI. ELECTRICAL SYMBOLS

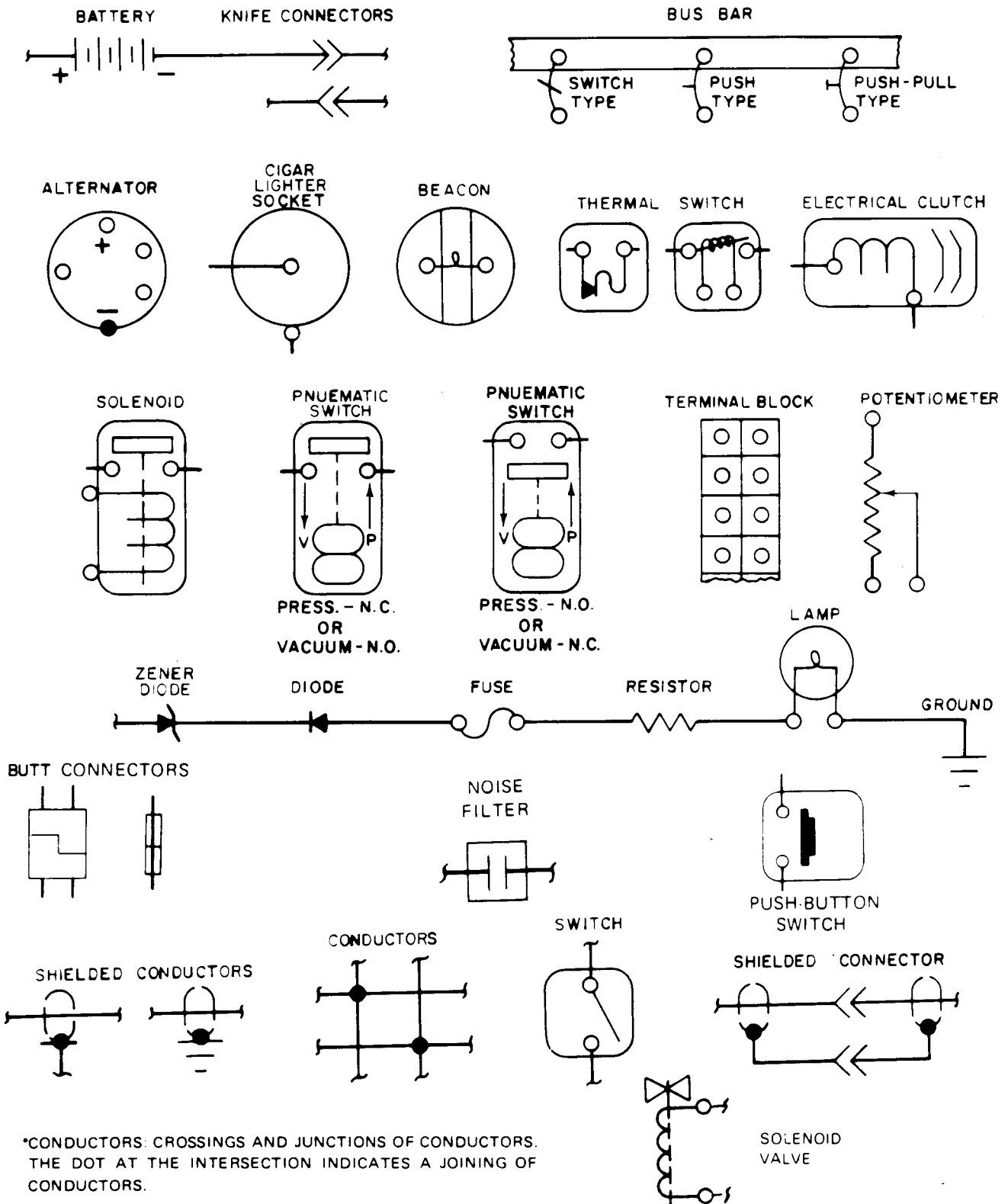

*CONDUCTORS: CROSSINGS AND JUNCTIONS OF CONDUCTORS. THE DOT AT THE INTERSECTION INDICATES A JOINING OF CONDUCTORS.

CHEROKEE ARROW III SERVICE MANUAL

TABLE XI-VII. ELECTRICAL WIRE CODING

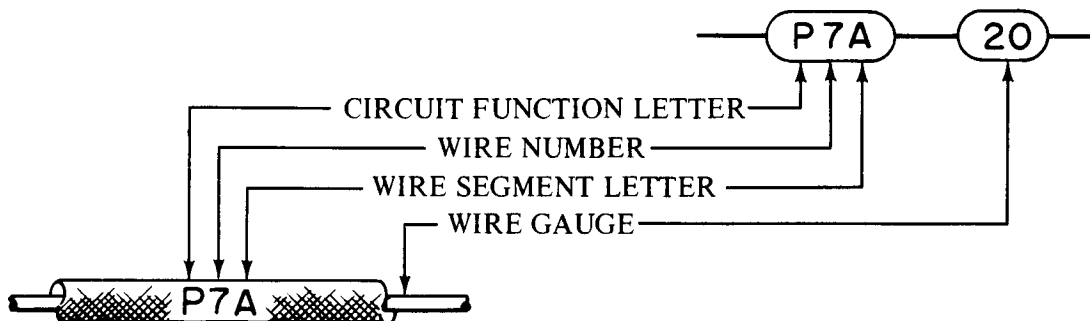

CIRCUIT FUNCTION LETTER	CIRCUITS
A	AUTOPILOT
B	CONTROL SURFACE
E	ENGINE INSTRUMENT
F	FLIGHT INSTRUMENT
G	LANDING GEAR
H	HEATER - VENTILATING & DEICING
L	LIGHTING
P	POWER
Q	FUEL & OIL
RP	RADIO POWER
RZ	RADIO AUDIO & INTERPHONE
J	IGNITION
RG	RADIO GROUND
W	WARNING
K	STARTER

CHEROKEE ARROW III SERVICE MANUAL

TABLE XI-VIII. INDEX - ELECTRICAL SYSTEM SCHEMATICS

Figure		Aerofiche Grid No.
11-46.	Anti-Collision Lights, PA-28R-201.....	2J7
11-47.	Fuel Pump, PA-28R-201.....	2J7
11-48.	Landing Light.....	2J7
11-49.	Navigation Lights.....	2J7
11-50.	Overhead Flood Lights.....	2J8
11-51.	Pitch Trim.....	2J8
11-52.	Pitot Heat.....	2J8
11-53.	Radio Lights	2J8
11-54.	Rotating Beacon	2J9
11-55.	Stall Warning.....	2J9
11-56.	Turn and Bank	2J9
11-57.	A/C Blower.....	2J9
11-58.	Avionics.....	2J10
11-59.	Engine Gauges, PA-28R-201.....	2J10
11-60.	Engine Gauges, PA-28R-201T	2J11
11-61.	Instrument Lights, PA-28R-201.....	2J11
11-62.	Instrument Lights, PA-28R-201T.....	2J12
11-63.	Alternator and Starter, PA-28R-201	2J13
11-64.	Alternator and Starter, PA-28R-201T (Early Models).....	2J14
11-64a.	Alternator and Starter (PA-28R-201 S/N's 2837001 and up, PA-28R-201T S/N's 2803001 and up).....	2J15
11-65.	Fuel Pump, PA-28R-201T.....	2J16
11-66.	Landing Gear.....	2J17
11-66a.	Landing Gear, Without Backup Gear Extender Functional or Installed.....	2J18

CHEROKEE ARROW III SERVICE MANUAL

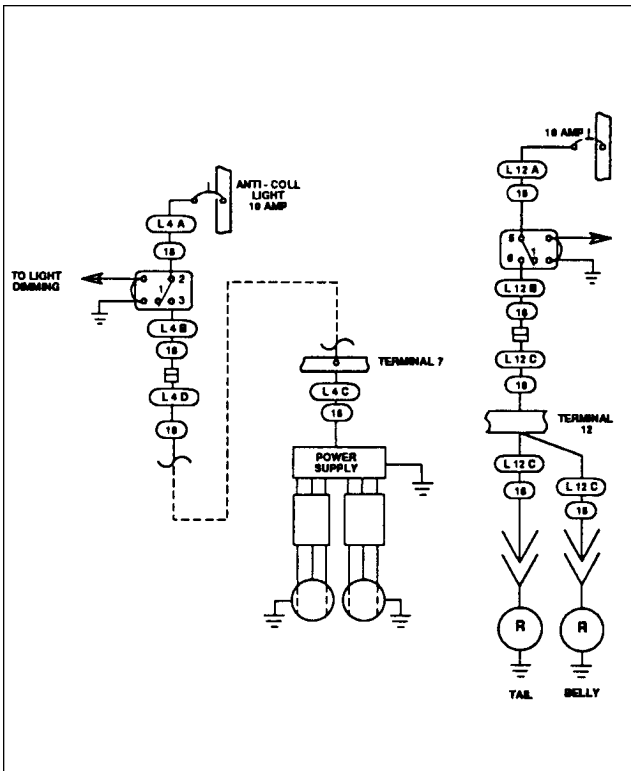

Figure 11-46. Anti-Collision Lights
PA-28R-201 and 201T

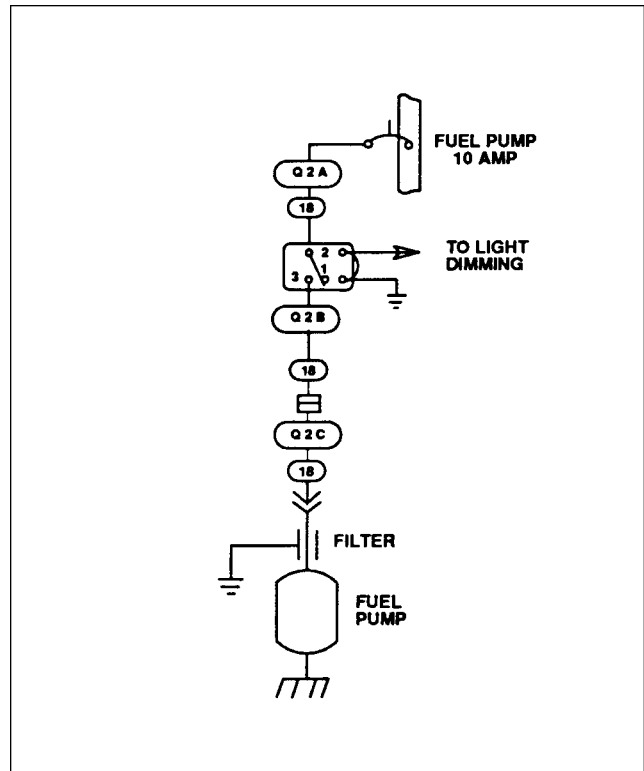

Figure 11-47. Fuel Pump PA-28R-201

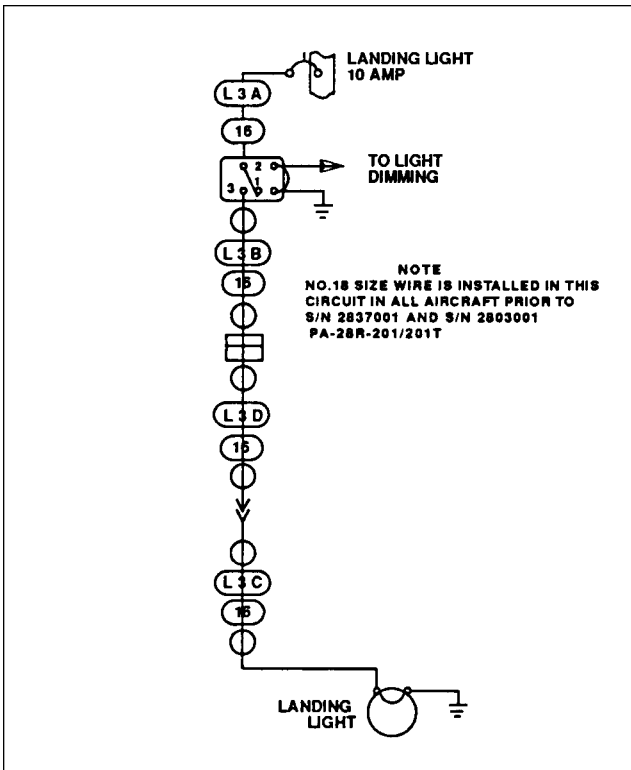

Figure 11-48. Landing Light,
PA-28R-201 and 201T

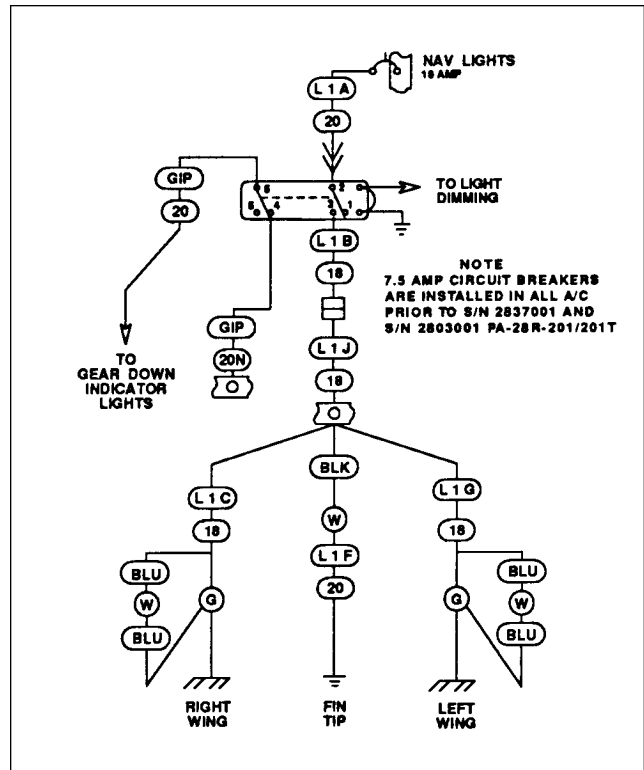

Figure 11-49. Navigation Lights
PA-28R-201 and 201T

CHEROKEE ARROW III SERVICE MANUAL

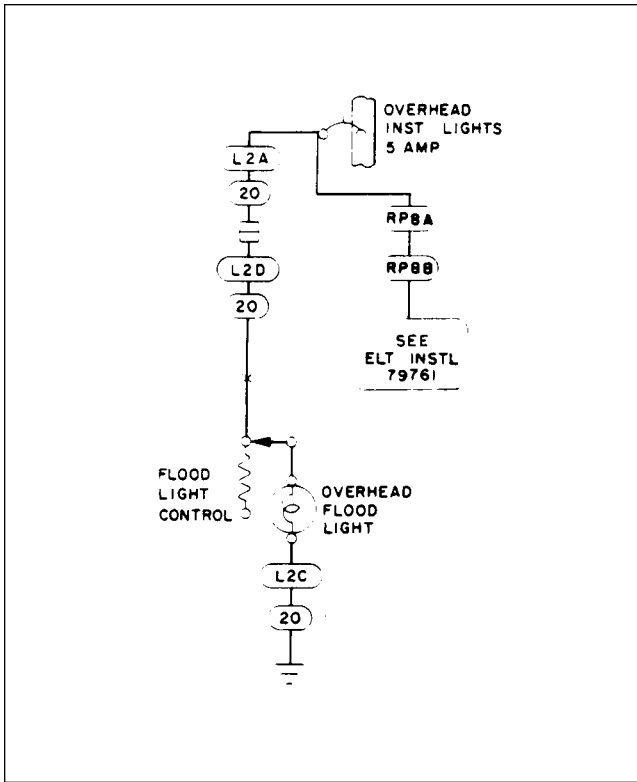

Figure 11-50. Overhead Flood Lights PA-28R-201 and 201T

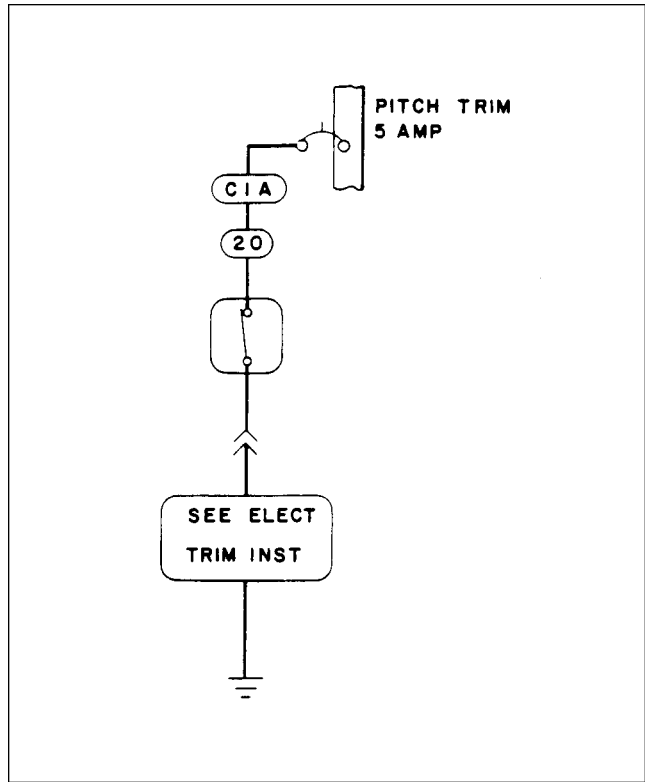

Figure 11-51. Pitch Trim, PA-28R-201 and 201T

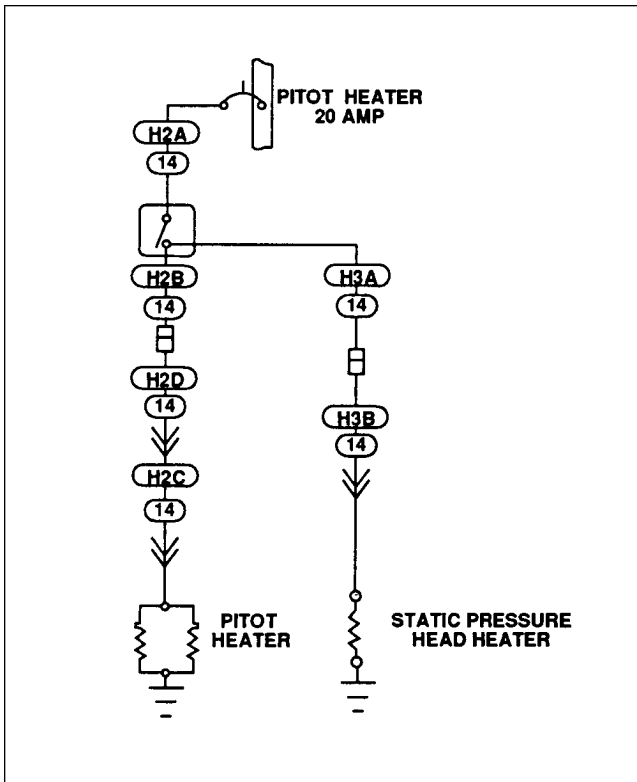

Figure 11-52. Pitot Heat, PA-28R-201 and 201T

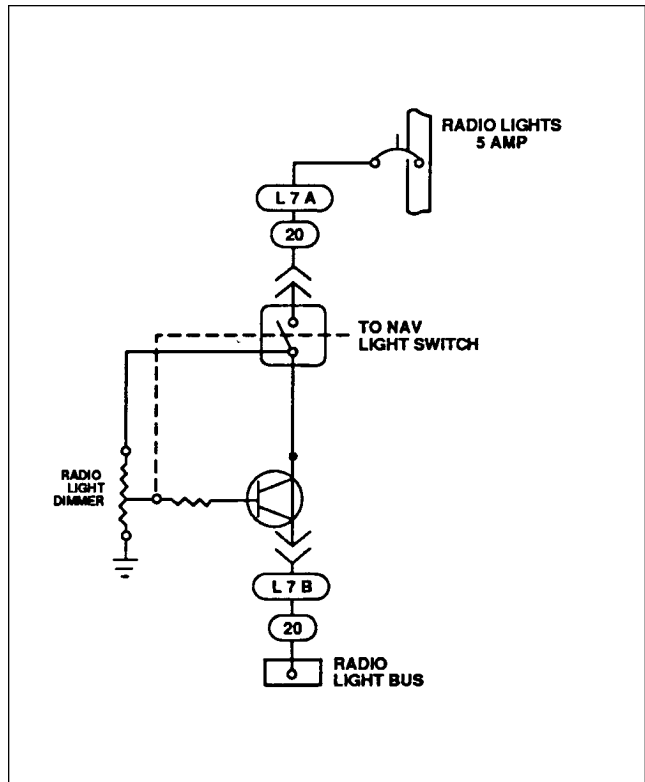

Figure 11-53. Radio Lights, PA-28R-201 and 201T

CHEROKEE ARROW III SERVICE MANUAL

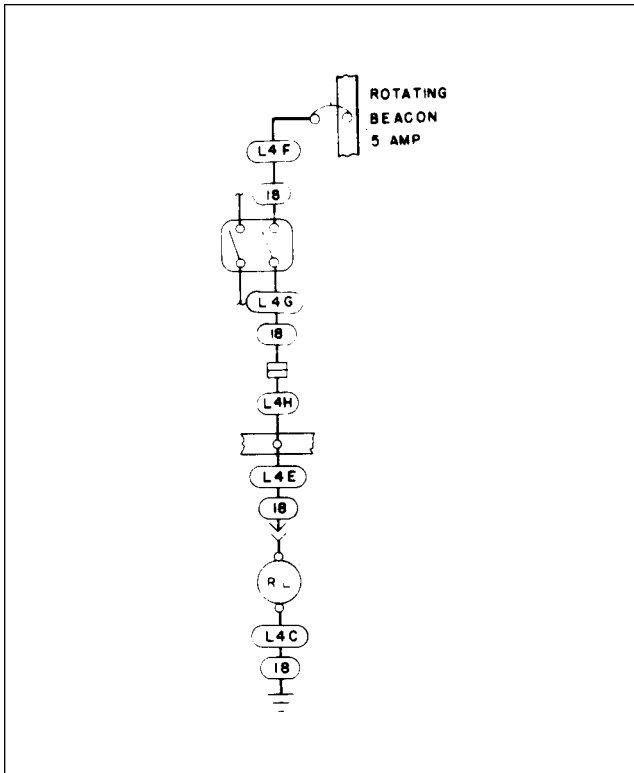

Figure 11-54. Rotating Beacon, PA-28R-201 and 201T

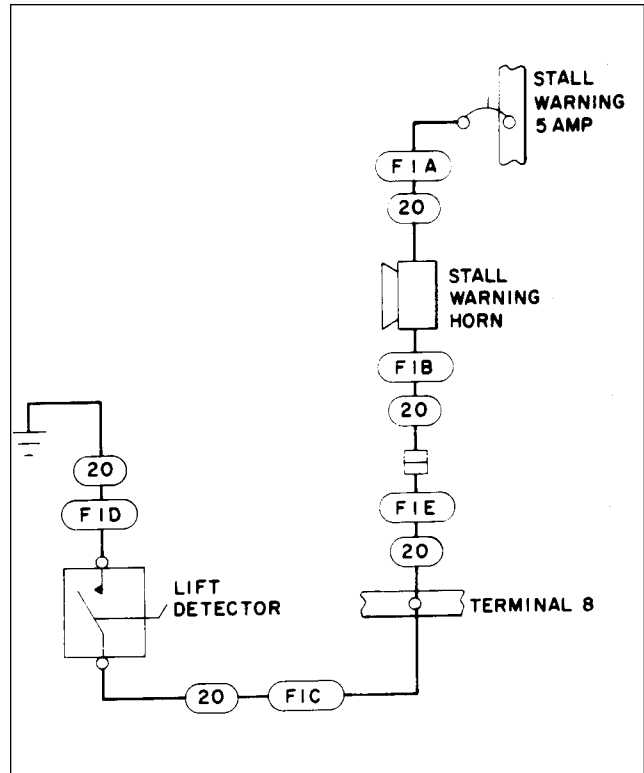

Figure 11-55. Stall Warning, PA-28R-201 and 201T

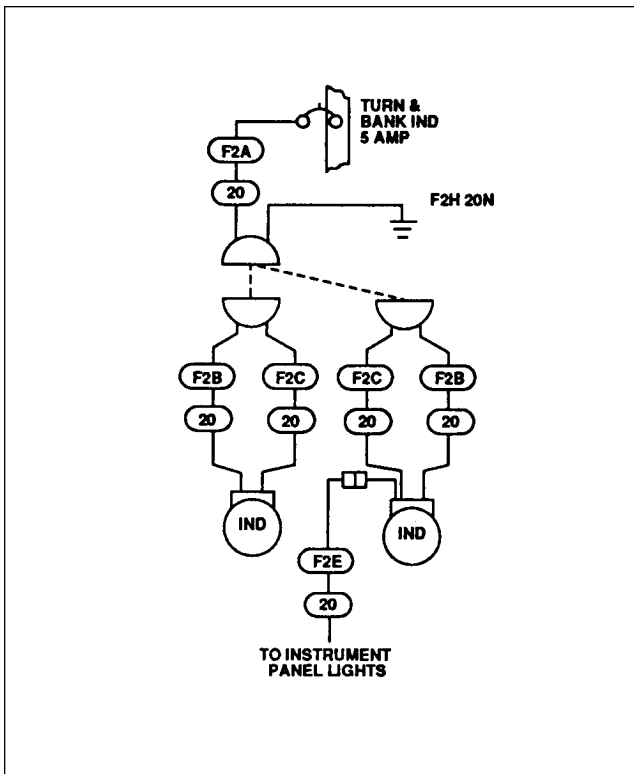

Figure 11-56. Turn and Bank, PA-28R-201 and 201T

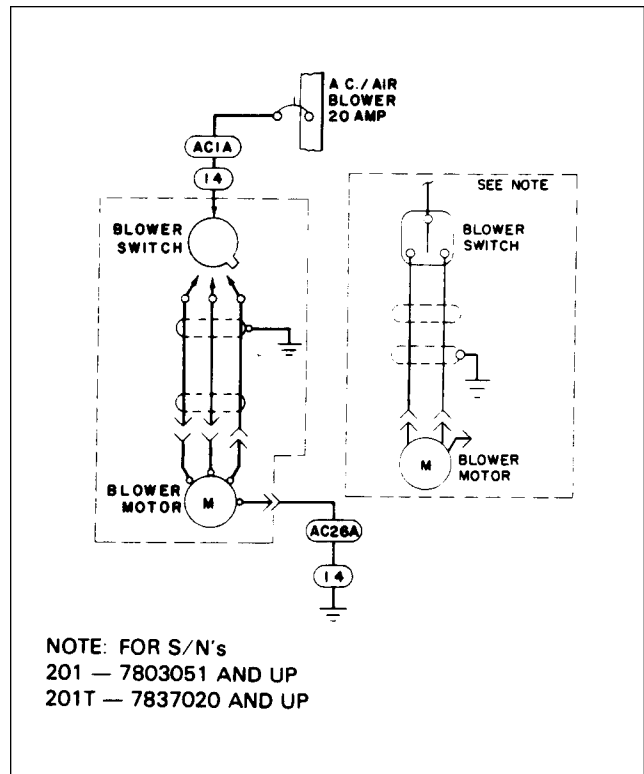

Figure 11-57. A/C Blower, PA-28R-201 and 201T

CHEROKEE ARROW III SERVICE MANUAL

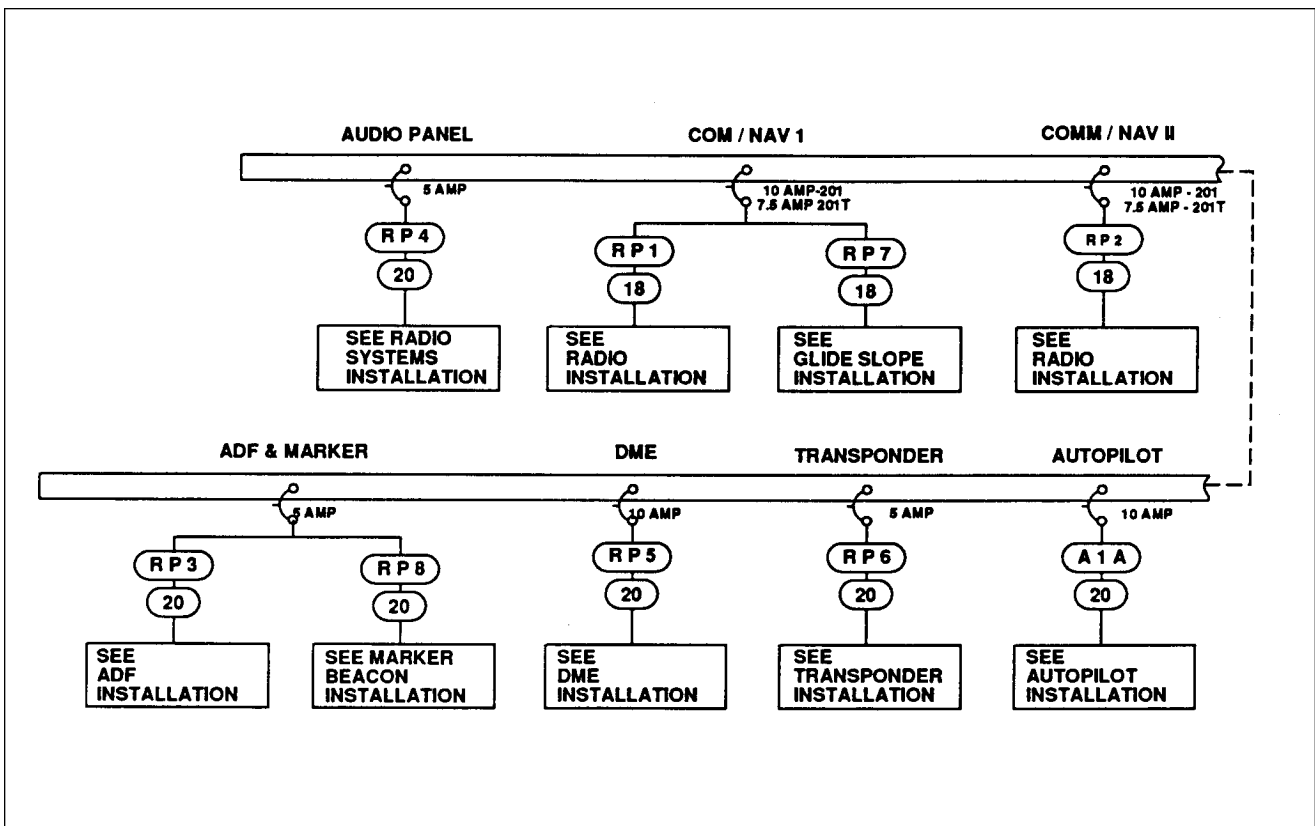

Figure 11-58. Avionics, PA-28R-201 and 201T

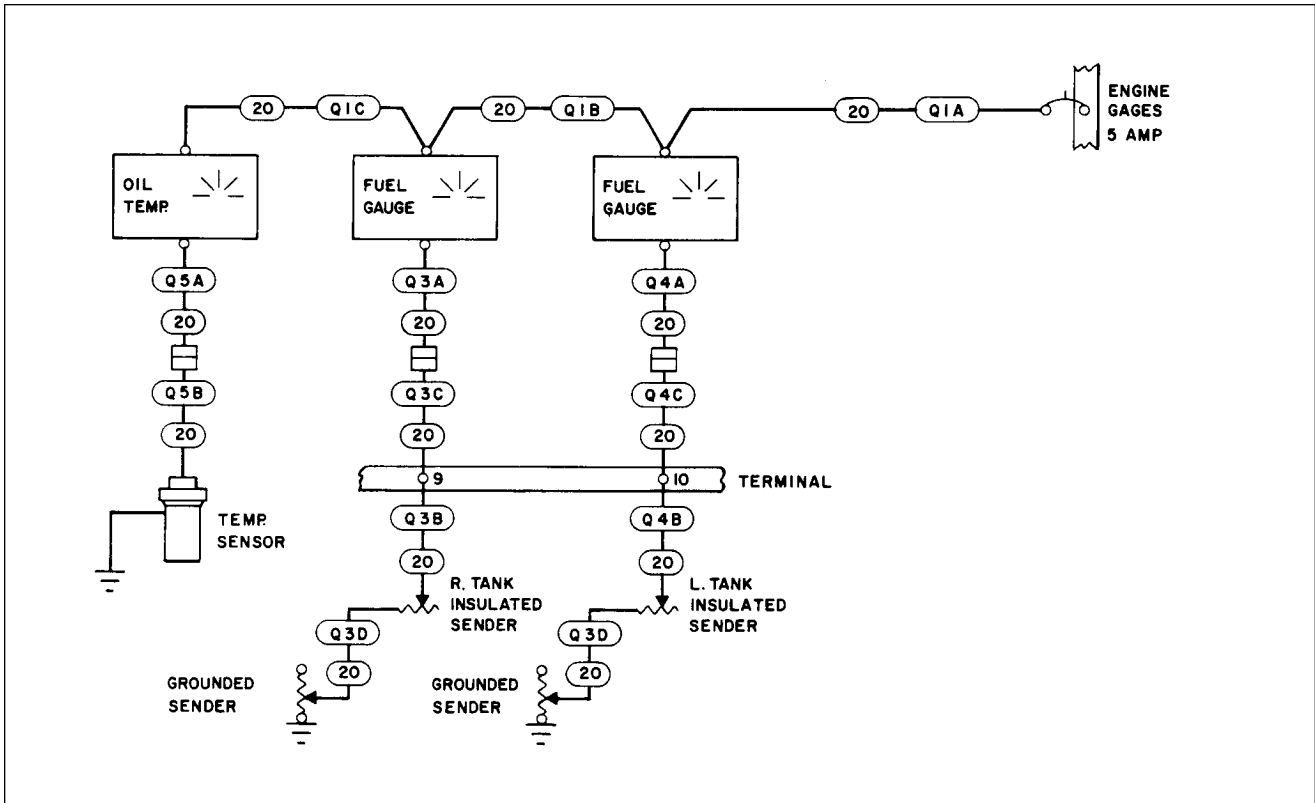

Figure 11-59. Engine Gauges, PA-28R-201

CHEROKEE ARROW III SERVICE MANUAL

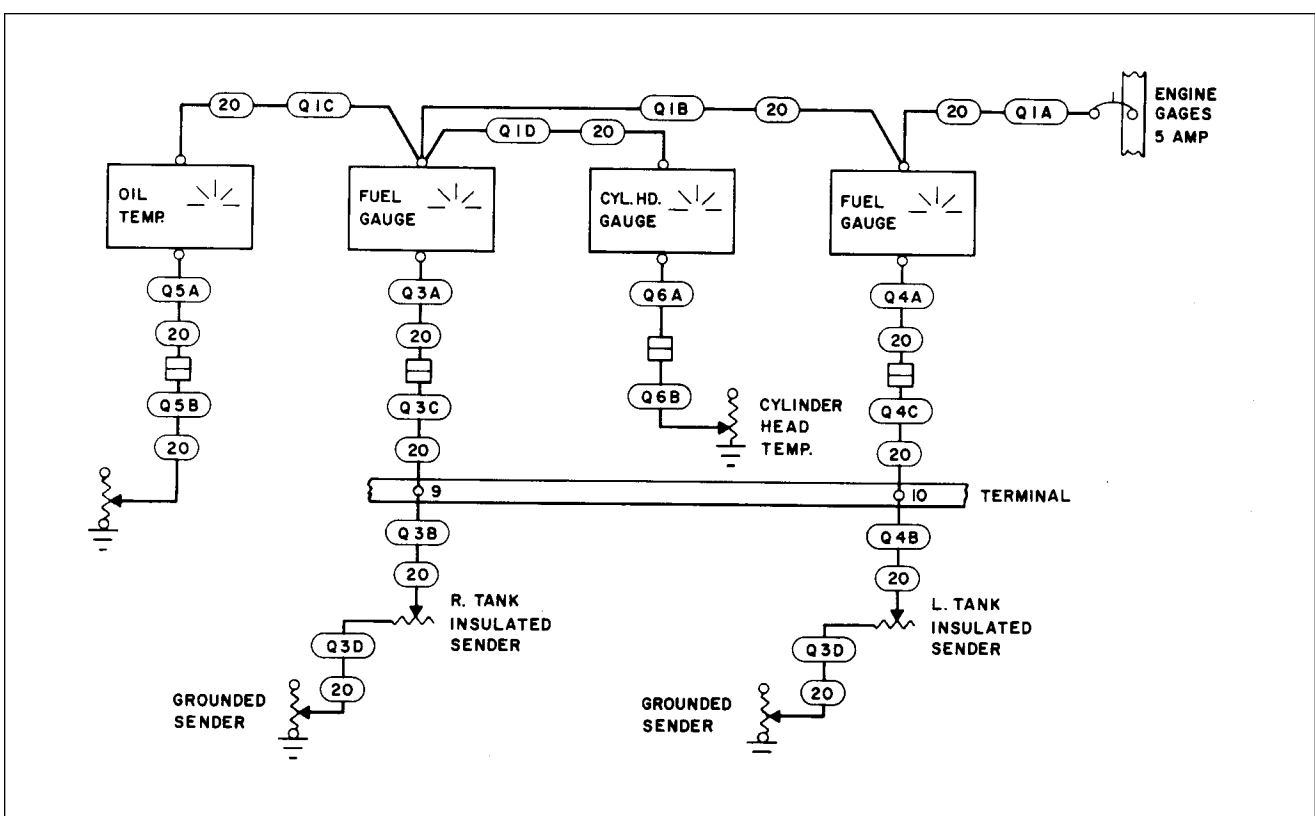

Figure 11-60. Engine Gauges, PA-28R-201T

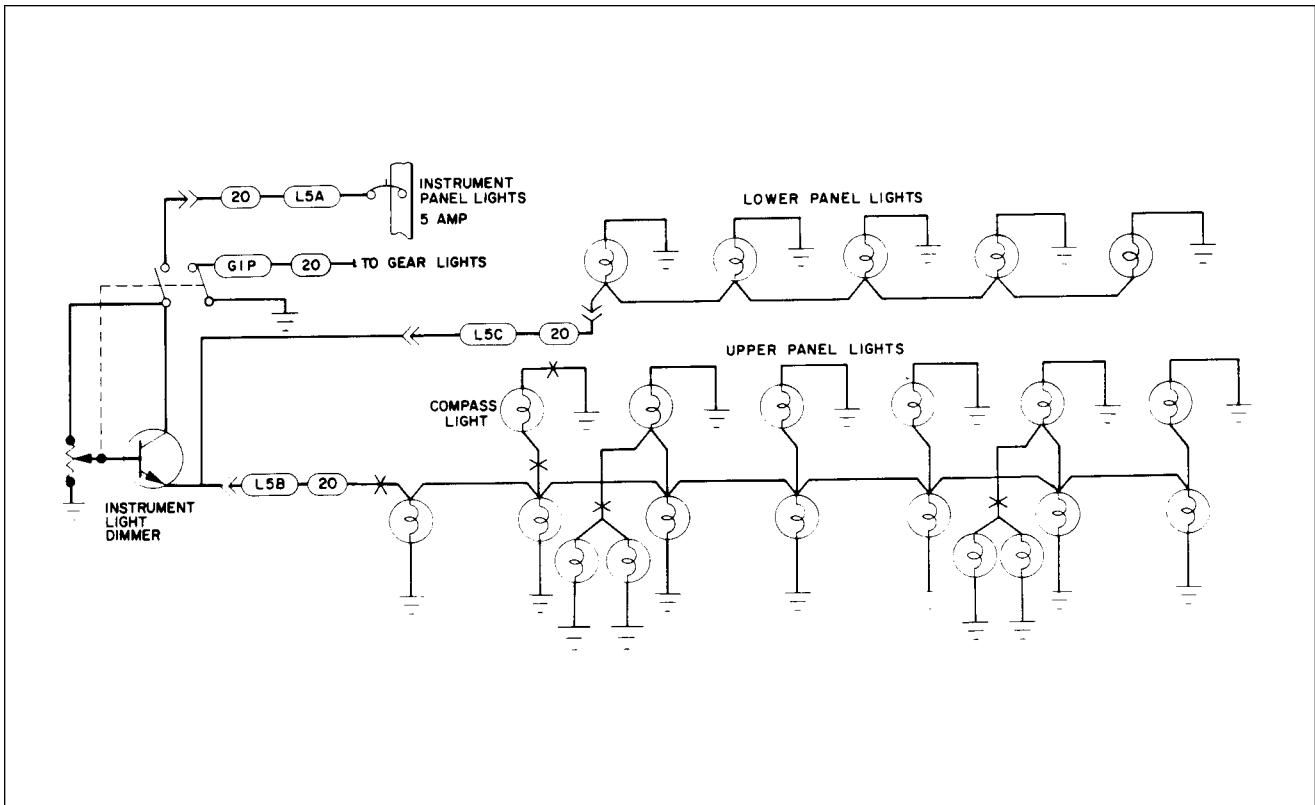

Figure 11-61. Instrument Lights, PA-28R-201

CHEROKEE ARROW III SERVICE MANUAL

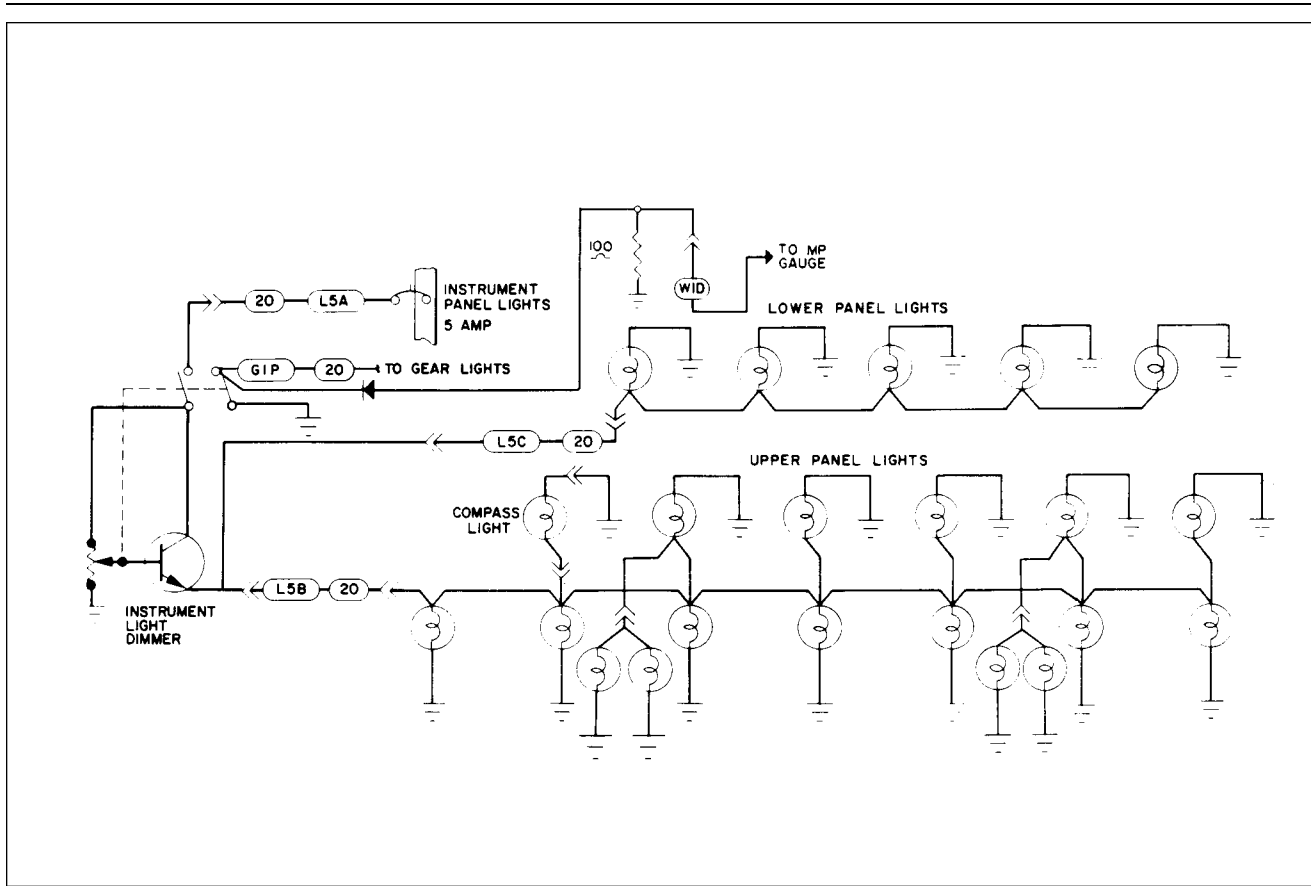

Figure 11-62. Instrument Lights, PA-28R-201T

CHEROKEE ARROW III SERVICE MANUAL

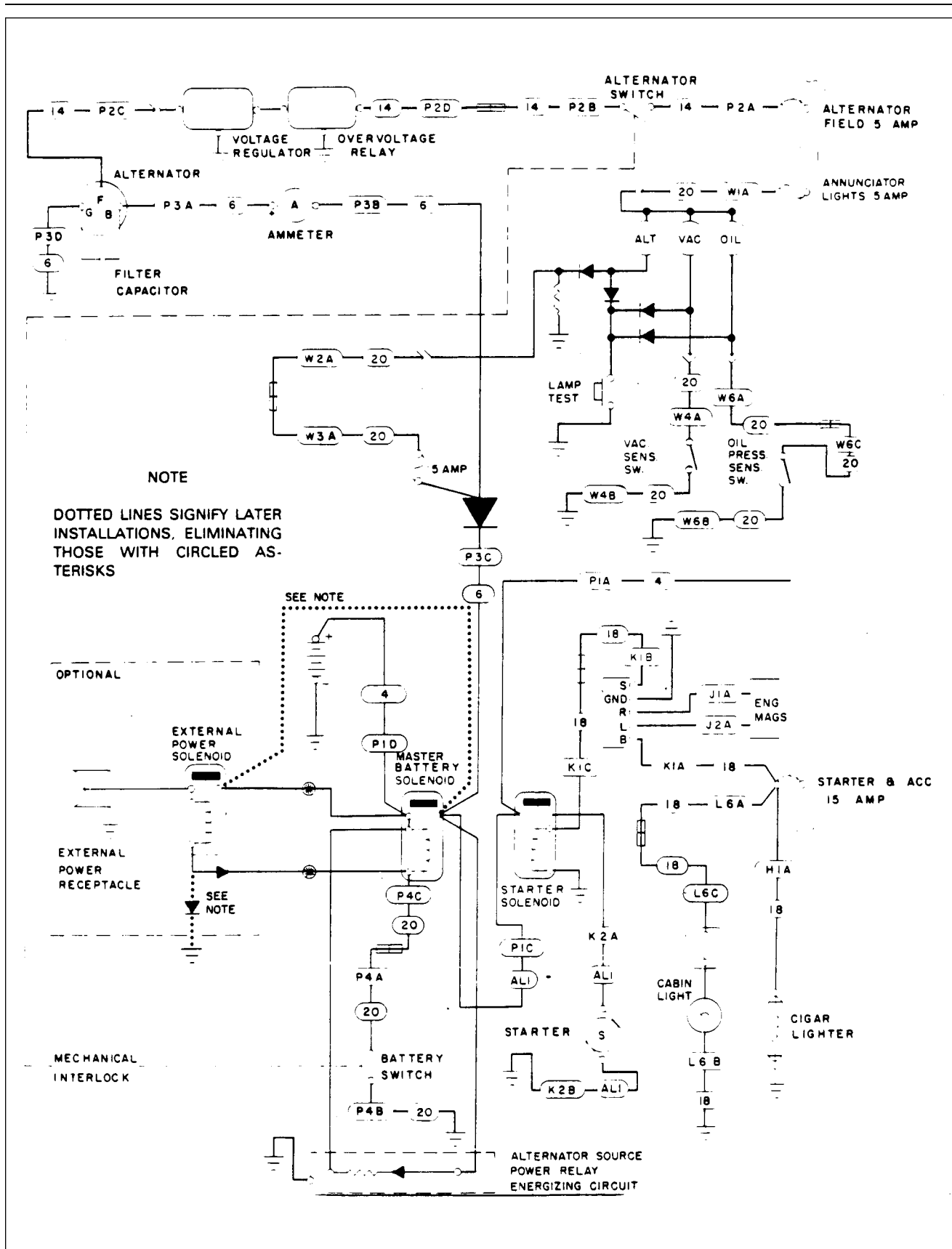

Figure 11-63. Alternator and Starter, PA-28R-201

CHEROKEE ARROW III SERVICE MANUAL

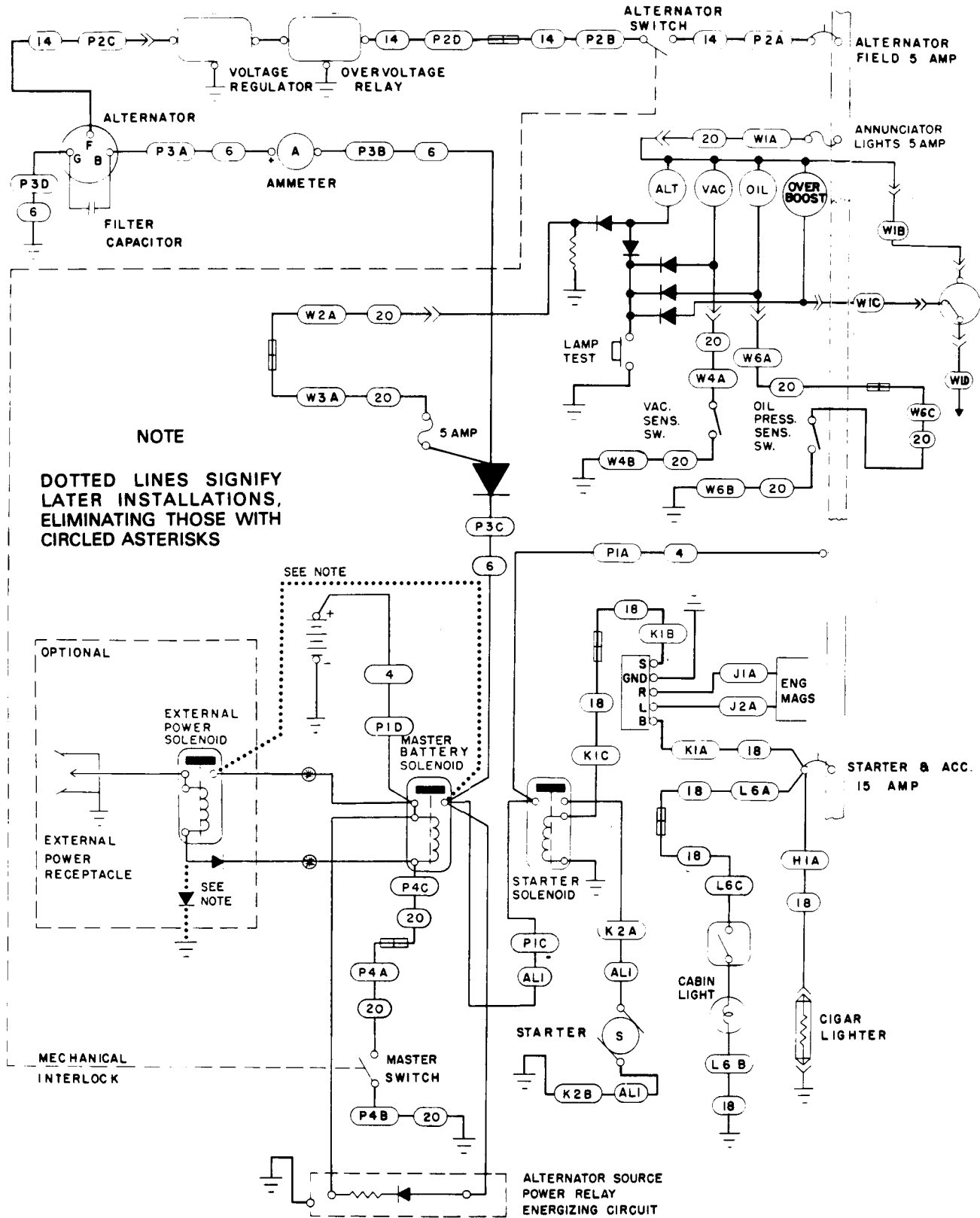

Figure 11-64. Alternator and Starter, PA-28R-201T (Early Models)

CHEROKEE ARROW III SERVICE MANUAL

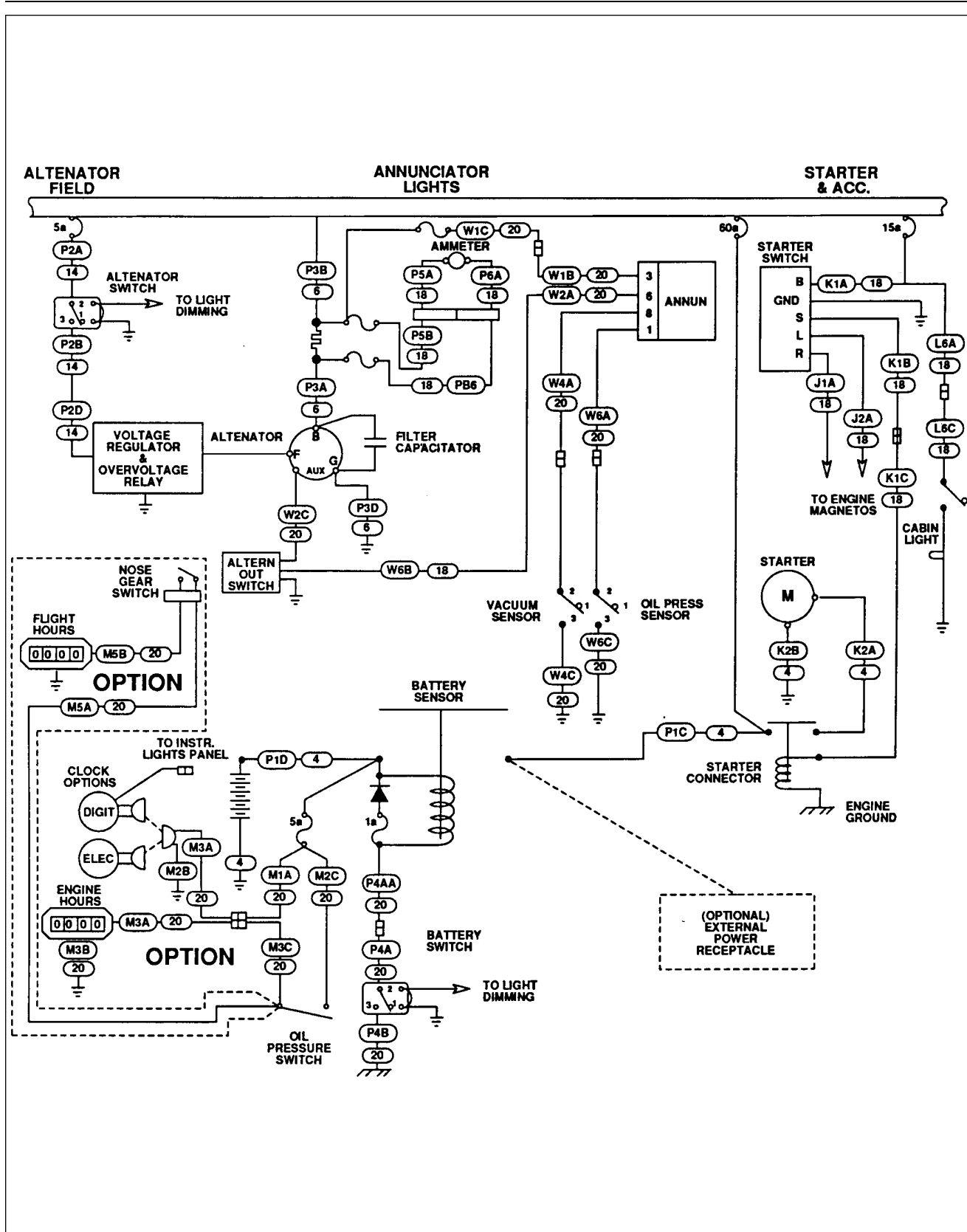

Figure 11-64a. Alternator and Starter Schematic
 (PA-28R-201 S/N's 2837001 & up, PA-28R-201T S/N's 2803001 & up)

CHEROKEE ARROW III SERVICE MANUAL

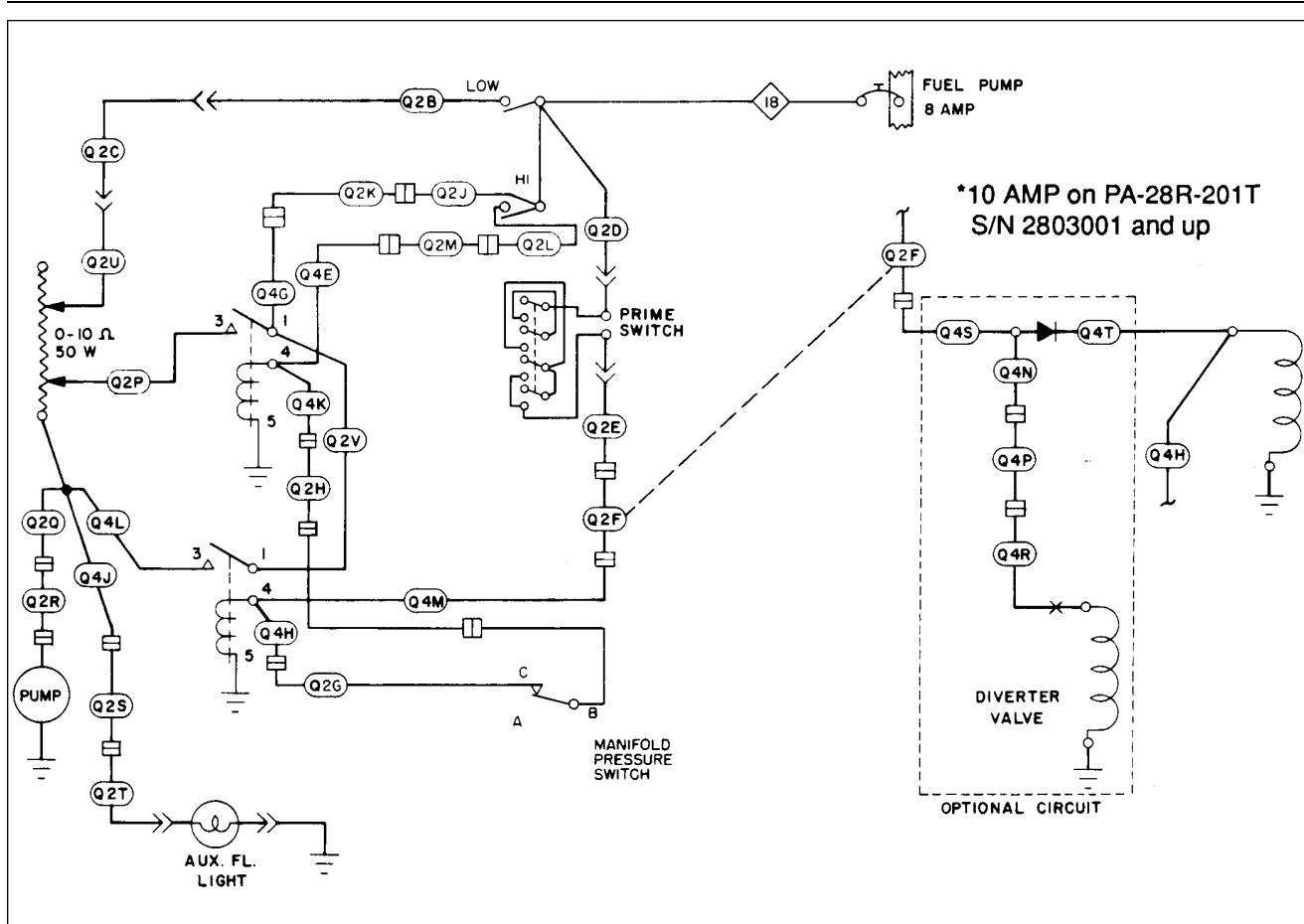

Figure 11-65. Fuel Pump, PA-28R-201T

CHEROKEE ARROW III SERVICE MANUAL

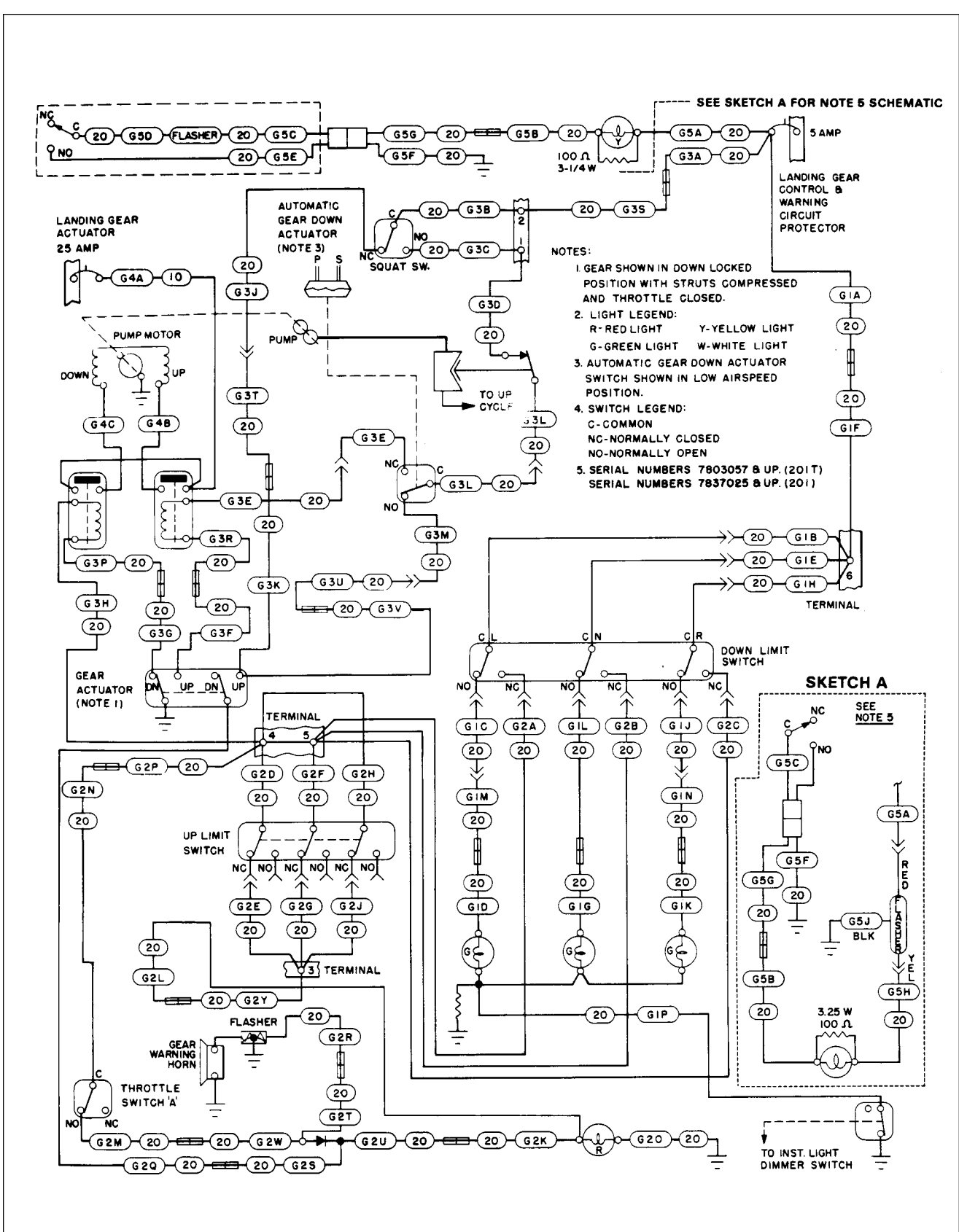

Figure 11-66. Landing Gear, PA-28R-201/201T

SECTION XII
ELECTRONICS

Paragraph	Aerofiche Grid No.
12-1. Introduction to Autoflight.....	2J20
12-2. Non-Piper A.F.C.S. Equipment Contacts.....	2J20
12-3. Piper A.F.C.S. Equipment Contacts	2J20
12-4. Introduction to Emergency Locator Transmitter.....	2J21
12-5. Emergency Locator Transmitter.....	2J21
12-6. Description	2J21
12-7. Battery Removal and Installation (Communications Components Corp.).....	2J21
12-8. Removal and Installation (Narco)	2J23
12-9. Pilot's Remote Switch	2J24
12-10. Testing Emergency Locator Transmitter	2J24
12-11. Testing Pilot's Remove Switch.....	2K1
12-12. Inadvertent Activation.....	2K2

CHEROKEE ARROW III SERVICE MANUAL

12-1. INTRODUCTION TO AUTOFLIGHT. Due to the wide variety of A.F.C.S. (Automated Flight Control System) options, it is mandatory to follow the service literature published by the individual manufacturer of the A.F.C.S. equipment installed in any particular airplane. This includes mechanical service such as: adjusting bridle cable tension, servo removal and installation, servo clutch adjustments, etc.

WARNING

When servicing or inspecting vendor equipment installed in Piper aircraft, it is the user's responsibility to refer to the applicable vendor publication.

12-2. NON-PIPER A.F.C.S. EQUIPMENT CONTACTS. Refer to the following list of Autopilot/Flight Director manufacturers to obtain service direction, parts support, and service literature.

Bendix Avionics Division
2100 N.W. 62nd Street
Fort Lauderdale, Florida 33310
(305) 776-4100/TWX 5109559884

Collins General Aviation Division
Rockwell International
Cedar Rapids, Iowa 52406
(319) 395-3625 Telex: 464421

Edo Corporation - Avionics Division
Box 610
Municipal Airport
Mineral Wells, Texas 76067
(817) 325-2517 Telex: 76067

King Radio Corporation
400 North Rodgers Road
Olathe, Kansas 66061
(913)782-0400 Telex: 4-2299-Kingrad

Sperry Flight Systems/Avionics Division
8500 Balboa Boulevard
P.O. Box 9028
Van Nuys, California 91409
(213) 894-8111 Telex: 65-1367

Global Navigation
2144 Michelson Drive
Irvine, California 92715
(714) 851-0119

12-3. PIPER A.F.C.S. EQUIPMENT. In the case of early models, Piper autopilot equipment bears the Piper name and the appropriate Piper Autopilot/Flight Director Service Manual shall be used.

NOTE

If a Roll Axis-only Autopilot is installed, or if no Autopilot is installed, consult the Piper Pitch Trim Service Manual - 753 771 for manual electric pitch trim service information.

CHEROKEE ARROW III SERVICE MANUAL

The following is a complete listing of Piper A.F.C.S. equipment service literature. It is imperative to correctly identify the Autopilot system by "faceplate" model name in order to consult the appropriate service manual. Each manual identifies the revision level and revision status as called out on the Master Parts Price List-Aerofiche published monthly by Piper. Consult the aircraft's parts catalog for replacement parts.

NAME	PIPER PART NO.
AutoControl I/II and AltiMatic I/II	753 798
AutoControl III and AltiMatic III and IIIB	753 723
AutoControl IIIB and AltiMatic IIIB-1	761 502
AltiMatic IIIC	761 602
AltiMatic V and V-1	761 525
AltiMatic V F/D and V F/D-1	761 526
AltiMatic X F.D./A.P. & X.A.P.	761 668
AutoFlite	753 720
AutoFlite II	761 481
Piper Pitch Trim (Manual-Electric)	757 771

CHEROKEE ARROW III SERVICE MANUAL

SECTION XII

ELECTRONICS

12-4. INTRODUCTION. This section of the manual contains information necessary to perform operational checks of the Emergency Locator Transmitter (ELT), with and without a pilot's remote switch. Included are the appropriate removal and installation instructions to facilitate battery replacement.

12-5. EMERGENCY LOCATOR TRANSMITTER.

12-6. DESCRIPTION. The ELT is an automatically activated emergency locator transmitter which, when activated, will radiate an omni-directional RF signal on the international distress frequencies. The radiated signal is modulated with a distinctive audio swept tone.

Electrical power for the ELT transmitter is supplied by its own self-contained magnesium or alkaline battery. Per FAA regulations, a magnesium battery must be replaced 2 years from the date of manufacture stamped on the battery pack and an alkaline battery must be replaced after 5 years of shelf life (replacement date is marked on the transmitter label). The battery must be replaced if the transmitter has been used in an emergency situation or if accumulated test time exceeds one hour. To replace the battery pack in the transmitter, it is necessary to remove the ELT from the airplane.

12-7. BATTERY REMOVAL AND INSTALLATION. (Communications Components Corp.) The ELT is located on the right side of the airplane tail section, ahead of the stabilator.

- a. Remove the access plate on the right side of fuselage aft of sta. 228.30.
- b. Rotate the ON/ARM/OFF switch to the OFF position.
- c. Disconnect the antenna coax cable (twist left, then pull outwards).
- d. Disconnect the harness to the pilot's remote switch.
- e. Remove the forward mounting bracket by pulling the black plastic knob out. Remove the transmitter from the airplane.
- f. Remove the six Phillips-head screws securing the transmitter cover. Remove the cover.
- g. Lift out the old battery pack.
- h. Copy the expiration date on the battery into the space provided on the external ELT name and date plate.
- i. Disconnect and replace with a new battery pack. The nylon battery connector is a friction fit and is easily removed by pulling on the exposed end.
- j. Insert transmitter into airplane and fit into place. Replace mounting bracket by pushing the black plastic knob into place.
- k. Reconnect the pilot's remote switch harness and the antenna coax cable to the transmitter.
- l. Set the ON/ARM/OFF switch to the ARM position.
- m. Reinstall the access plate previously removed.

NOTE

It may be advisable to test the unit operation before installing the access plate. (See paragraph 12-9.)

NOTE

Inspect the external whip antenna for any damage. Avoid bending the whip. Any sharply bent or kinked whip should be replaced. Antenna damage may cause structural failure of whip in flight.

CHEROKEE ARROW III SERVICE MANUAL

12-8. REMOVAL AND INSTALLATION (NARCO). The ELT is located on the right side of the airplane tail section ahead of the stabilator.

1. Remove the access panel at fuselage station 228.30.
2. Set the ON/OFF/ARM switch on the transmitter to OFF.
3. Disconnect antenna coaxial cable from ELT.
4. Remove ELT from its mounting bracket by releasing the latch on the strap and sliding the ELT off the bracket.
5. Extend the portable antenna.
6. Unscrew the four screws that hold the control head to the battery casing and slide apart.
7. Disconnect the battery terminals from the bottom of the circuit board.
8. Discard old battery pack. (DO NOT EXPOSE TO FLAME.)

CAUTION

The battery pack is shipped with a sealant on the inside lip so that a water tight seal will be retained. DO NOT REMOVE THIS SEALANT.

9. Connect new battery pack terminals to the bottom of the circuit board.
10. Reinsert the control head section into the battery pack being careful not to pinch any wires, and replace the four screws. If the four holes do not line up, rotate the battery pack 180° and reinsert.
11. Slide the portable antenna back into the stowed position.
12. Place transmitter into its mounting bracket and fasten the strap latch.
13. Connect the antenna coaxial cable to the ELT and ensure that the contact separator is inserted between the antenna contact finger and the portable antenna.
14. Press RESET button and set ON/OFF/ARM switch to ARM.
15. Make an entry in the aircraft logbook, including the new battery expiration date.
16. A unit operational check may now be performed on the ELT. (Refer to Testing Emergency Locator Transmitter, paragraph 12-10.)

NOTE

Inspect the external whip antenna for any damage. Avoid bending the whip. Any sharply bent or kinked whip should be replaced. Antenna damage may cause structural failure of whip in flight.

CHEROKEE ARROW III SERVICE MANUAL

12-9. PILOT'S REMOTE SWITCH. A pilot's remote switch, located on the left side panel, is provided to allow the transmitter to be controlled from inside the cabin. The pilot's remote switch is placarded ON, AUTO/ARM and OFF/RESET. The switch is normally left in the AUTO/ARM position. The aircraft master switch must be ON to turn the transmitter OFF. To actuate the transmitter for tests or in the event the automatic feature was not triggered by impact, move the switch upward to the ON position and leave it in that position as long as transmission is desired.

12-10. TESTING EMERGENCY LOCATOR TRANSMITTER. The transmitter operates on the emergency frequencies of 121.5 and 243 MHz; both of these frequencies are monitored by the various FAA installations. Before performing any operational test of the ELT, the following precautions should be observed:

CAUTION

Testing of an ELT should be conducted in a screen room or meter enclosure to ensure that electromagnetic energy is not radiated during testing. If a shielded enclosure is not available, testing may be performed in accordance with the following procedures:

- 1. Test should be no longer than three audio sweeps.*
- 2. If the antenna is removed, a dummy load should be substituted during the test.*
- 3. Test should be conducted only within the time period made up of the first five minutes after any hour.*
- 4. If the operational tests must be made at a time not included within the first five minutes after the hour, the test should be coordinated with the closest FAA Tower or Flight Service Station.*

Consult FAA Advisory Circular AC 20-81 for detailed information concerning above caution.

- Remove the access plate on the right side of the fuselage aft of sta. 228.30.
- Tune the aircraft communications receiver to 121.5 MHz and switch the receiver ON; deactivate the squelch and turn the receiver volume up until a slight background noise is heard.

NOTE

If the aircraft is not fitted with a communications receiver, request that the tower listen for your test.

- On the transmitter, set the ON/ARM/OFF switch to the ON position. Keep the switch in this position for only a few seconds; then set to the OFF position. Return to the ARM position.

NOTE

The test transmission should have been picked up by the aircraft communications receiver and/or control tower. During cold weather, there may be a slight delay before transmission occurs.

CHEROKEE ARROW III SERVICE MANUAL

- d. A transmitter which is functioning properly should emit a characteristic downward swept tone.
- e. When the test is completed, ascertain the transmitter ON/ARM/OFF switch is in the ARM position.
- f. Place the access panel on the right side of the fuselage aft of sta. 228.30.

WARNING

Whenever the unit is checked by moving the transmitter ON/ARM/OFF switch from the ARM to the ON position, it must then be moved to the OFF position before reverting to the ARM position again.

CAUTION

Under normal conditions, the transmitter switch must be set to arm.

12-11. TESTING PILOT'S REMOTE SWITCH. Before performing any operational test of the pilot's remote switch, the same precautions noted in paragraph 12-10 must be observed.

- a. Tune the aircraft communications receiver to 121.5 MHz and switch the receiver ON, deactivate the squelch and turn the receiver volume up until a slight background noise is heard.

NOTE

If the aircraft is not fitted with a communications receiver, request that the tower listen for your test.

- b. Set the pilot's remote switch to the ON position. Hold the switch in this position for only a few seconds.

NOTE

The test transmission should have been picked up by the aircraft communications receiver and/or control tower. During cold weather, there may be a slight delay before transmission occurs.

- c. Set the pilot's remote switch to the momentary OFF, RESET position. The switch is spring loaded to automatically return to the ARM position.

CHEROKEE ARROW III SERVICE MANUAL

12-12. INADVERTENT ACTIVATION. The remote switch allows the pilot to turn off the transmitter inadvertently activated by impact or improper switch position. The pilot simply selects the momentary OFF, RESET position. The transmitter shuts off and the spring loaded switch automatically returns to the ARM position. The aircraft master switch must be ON to turn transmitter OFF with the remote switch. Stopping inadvertent activation at the transmitter itself is accomplished in the following manner:

- a. Improper switch selection is corrected by rotating the switch to the OFF position and then to the ARM position.
- b. If the transmitter is inadvertently activated through impact, deactivate by pushing in on the OFF/ARM/ON switch.

NOTE

As a routine precaution, it is recommended that the ELT battery be replaced at the earliest opportunity after inadvertent activation and a functional test be made in accordance with paragraph 12-10. Note, however, that the problem may not be in the transmitter. Check the following:

1. Proper spacing of antennas so as to minimize antenna conducted RF.
2. Rigidity of the transmitter installation.

CAUTION

Under normal conditions, the pilot's remote switch must be set to ARM position.

CHEROKEE ARROW III SERVICE MANUAL

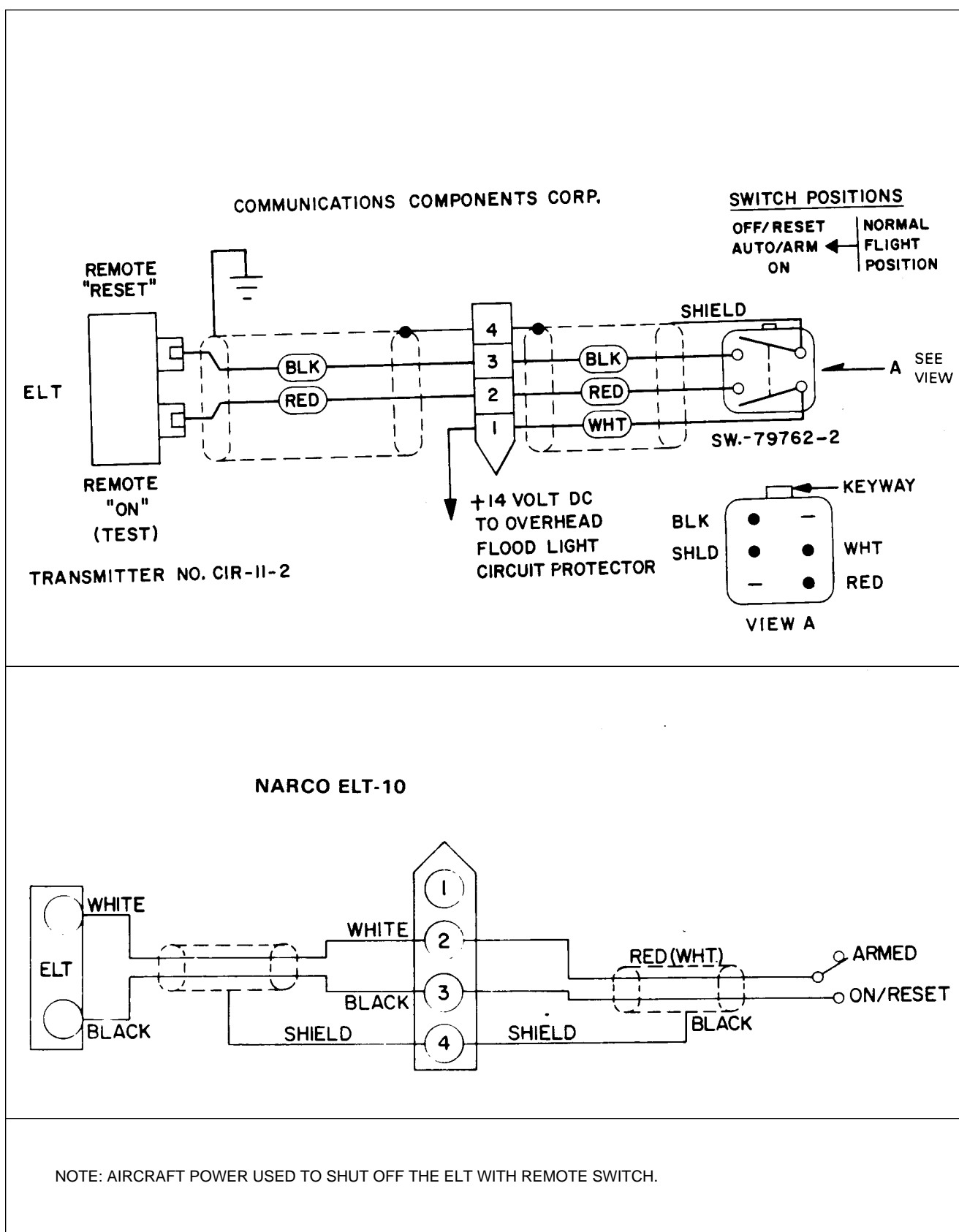

Figure 12-1. ELT Schematic (Typical)

CHEROKEE ARROW III SERVICE MANUAL

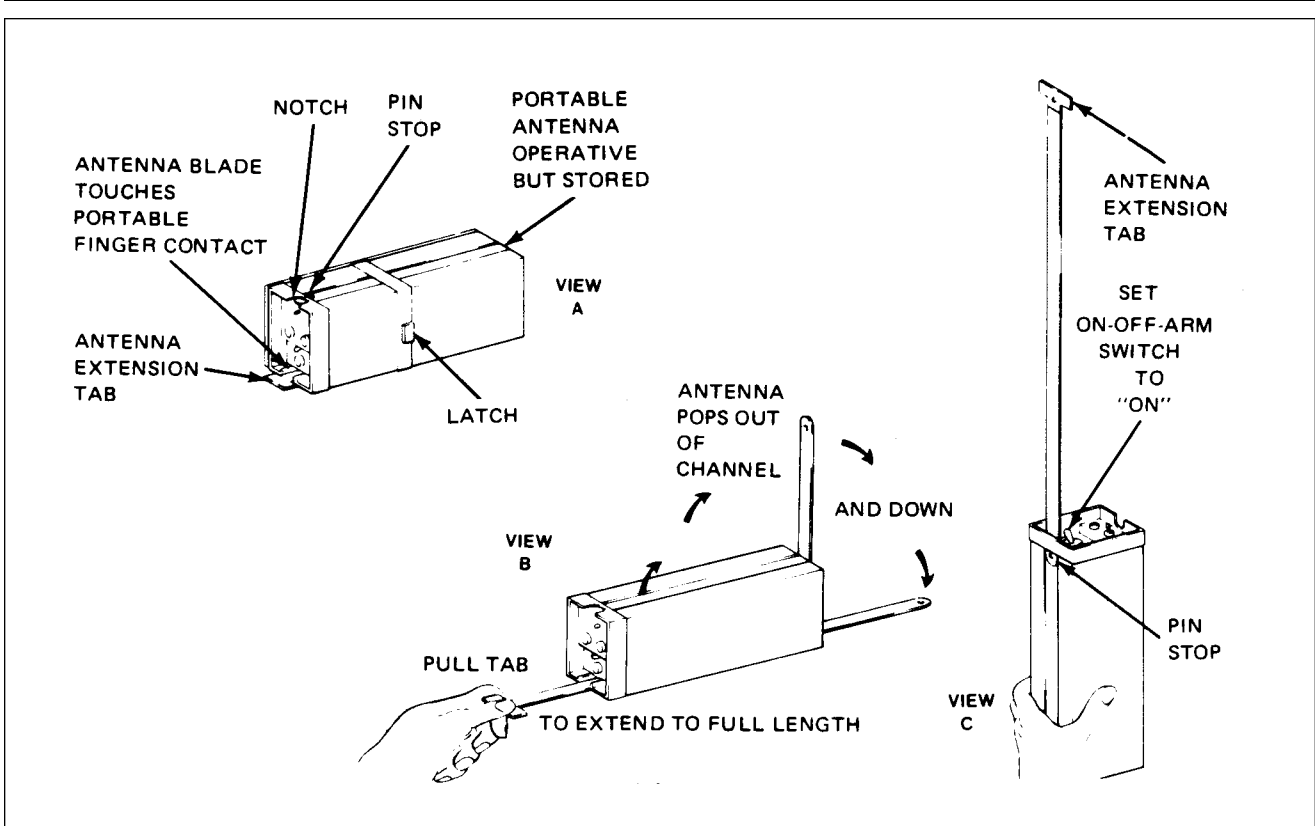

Figure 12-2. ELT Portable Folding Antenna (Narco)

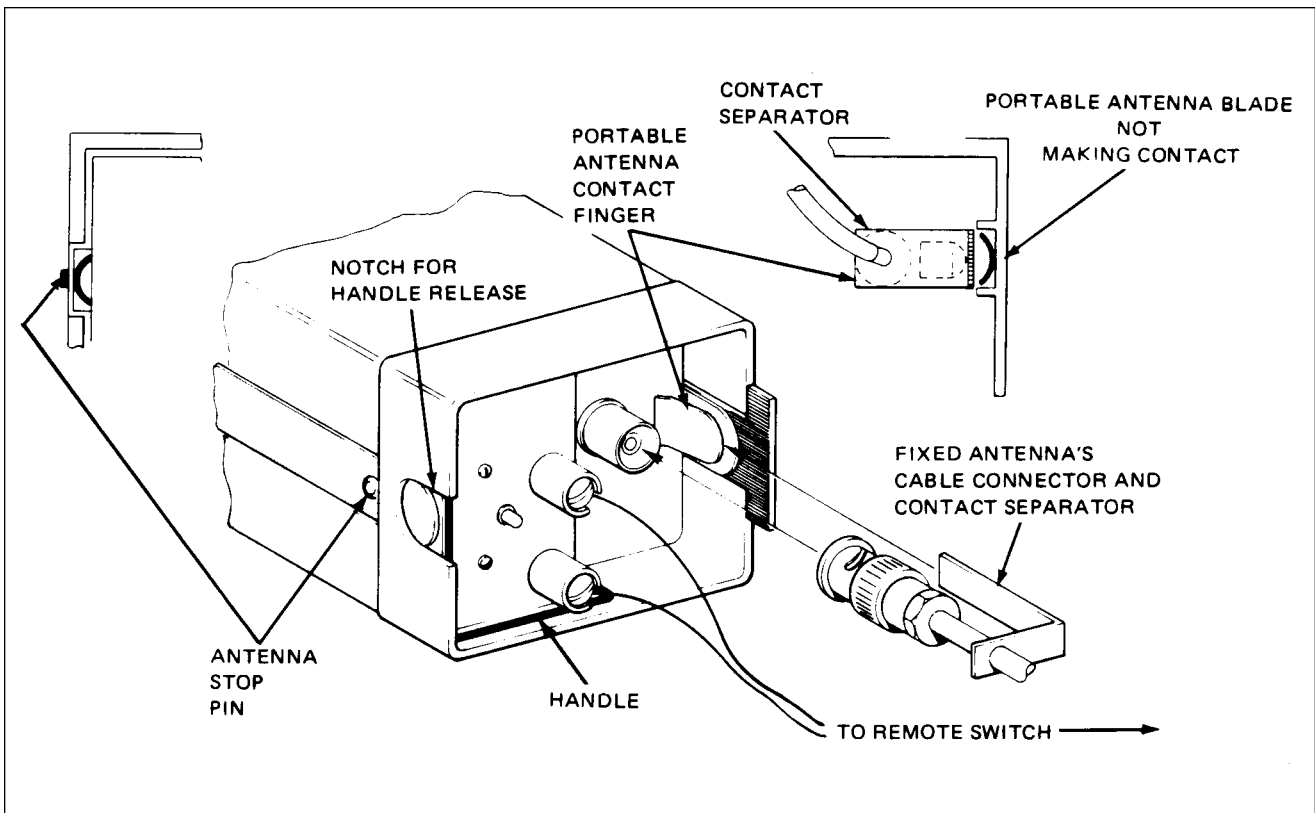

Figure 12-3. ELT Using Fixed Aircraft Antenna (Narco)

SECTION XIII
HEATING AND VENTILATING

Paragraph	Aerofiche Grid No.
13-1. Introduction	2K6
13-2. Description	2K6
13-3. Heater Maintenance.....	2K6
13-4. Overhead Vent System	2K6

CHEROKEE ARROW III SERVICE MANUAL

SECTION XIII

HEATING AND VENTILATING SYSTEM

13-1. INTRODUCTION. Because of the simplicity of the heating and ventilating system installed on both the PA-28R-201 and PA-28R-201T models, the operation and maintenance instructions of the components are contained in paragraph 13-3. A pictorial description of these systems may be found in Figure 13-1 or 13-2 and Figure 13-3.

13-2. DESCRIPTION. On the PA-28R-201 model, the heat for the cabin is provided by a hot air muff installed on the exhaust manifold. Fresh air enters the engine compartment through the nose cowling, passes over the engine and is vented to the heater muff through a flexible hose located on the baffling at the rear of the engine. With the PA-28R-201T model, heat is supplied by a hot air exchanger installed on the exhaust tail pipe. In this case, the fresh air enters through the area surrounding the landing light and is vented to the heat exchanger, through a hose aft of the landing light. In both models, the air is then heated and vented into the cabin area through a valve which can be controlled from the instrument panel. When the valve is completely closed off, the heated air is vented back into the engine compartment. The heater outlet in the cabin is located between the two front seats. Control for the heater system is located on the right panel below the instruments. The windshield is kept clear of frost, ice, etc. by a defroster system which also operates from the above mentioned muff or exchanger but has an individual control.

Fresh air for both models is picked up from an inlet in the leading edge of each wing. The air passes through the wings to individually controlled outlets located just forward of each seat. An air vent is located in the bottom of the fuselage to take the exhaust air from the cabin interior.

13-3. HEATER MAINTENANCE. If the exhaust manifold should become defective, carbon monoxide fumes may be discharged into the cabin area, therefore, it is imperative that the exhaust manifold (on PA-28R-201) be inspected regularly. (Refer to the latest revision Piper Service Bulletin 691 for Muffler Assembly Inspection Procedure.) The heater exchanger must be removed in order to inspect the tailpipe on PA-28R-201T, the heat muff must be removed before the manifold assembly can be inspected on PA-28R-201. Check the operation of the push-pull controls to ensure the valve doors function properly. When the controls are pulled out, the door should be completely open to permit full air flow. When the controls are pushed in, the valves should close off all air passage and vent the air into the engine compartment. Refer to either Figure 13-1 or 13-2 for an illustration of the heater system.

13-4. OVERHEAD VENT SYSTEM. "NOT AVAILABLE WITH AIR CONDITIONING." The overhead vent system utilizes the ducting noted in Figure 13-3. Air enters an inlet at the top of the fin and is ducted through the vent system. Small louvers control the flow of air into the cabin. This vent system may also be equipped with a blower (optional). This blower, mounted aft of the close-out panel underneath the top of the fuselage, will force air through the overhead vent system whenever desired.

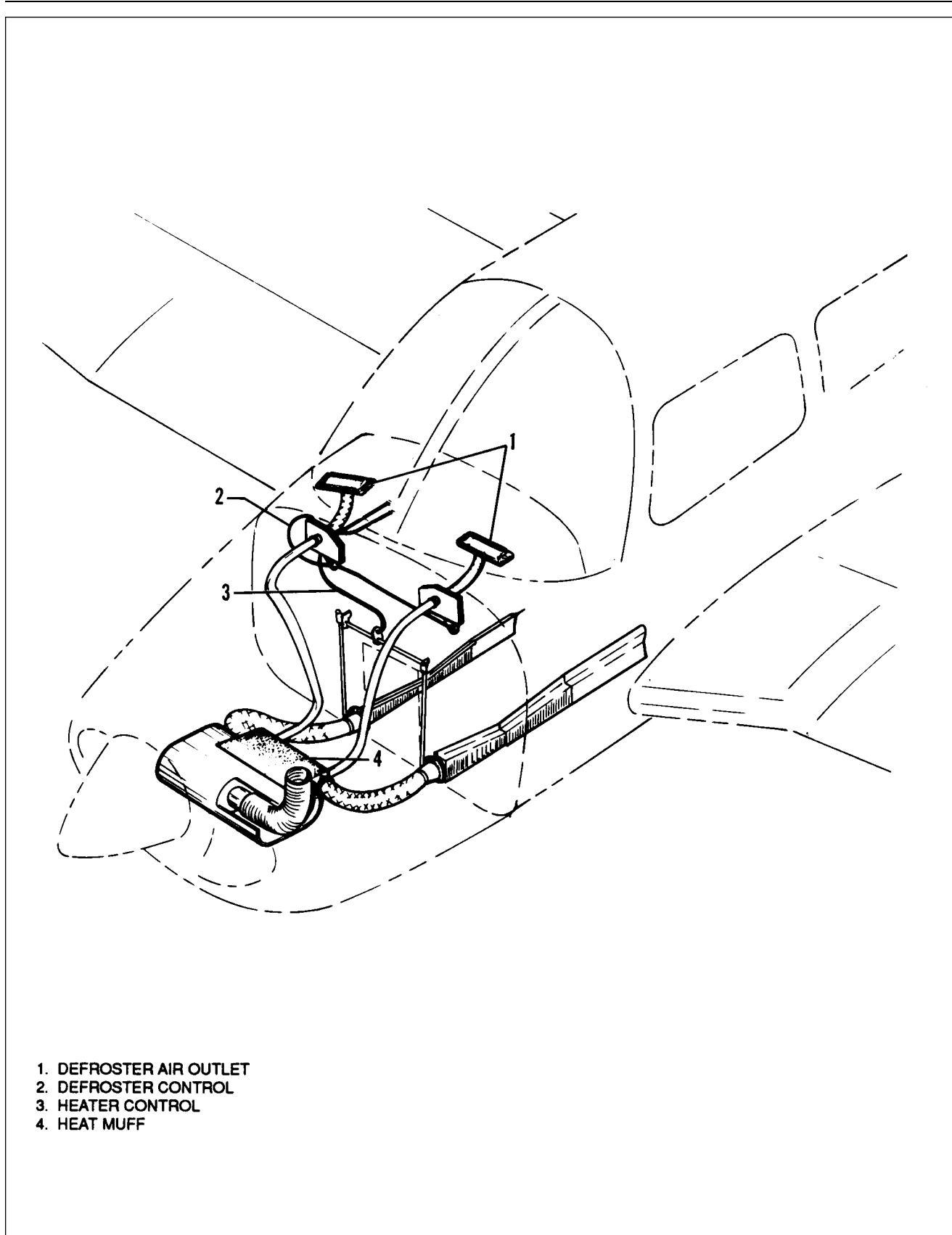
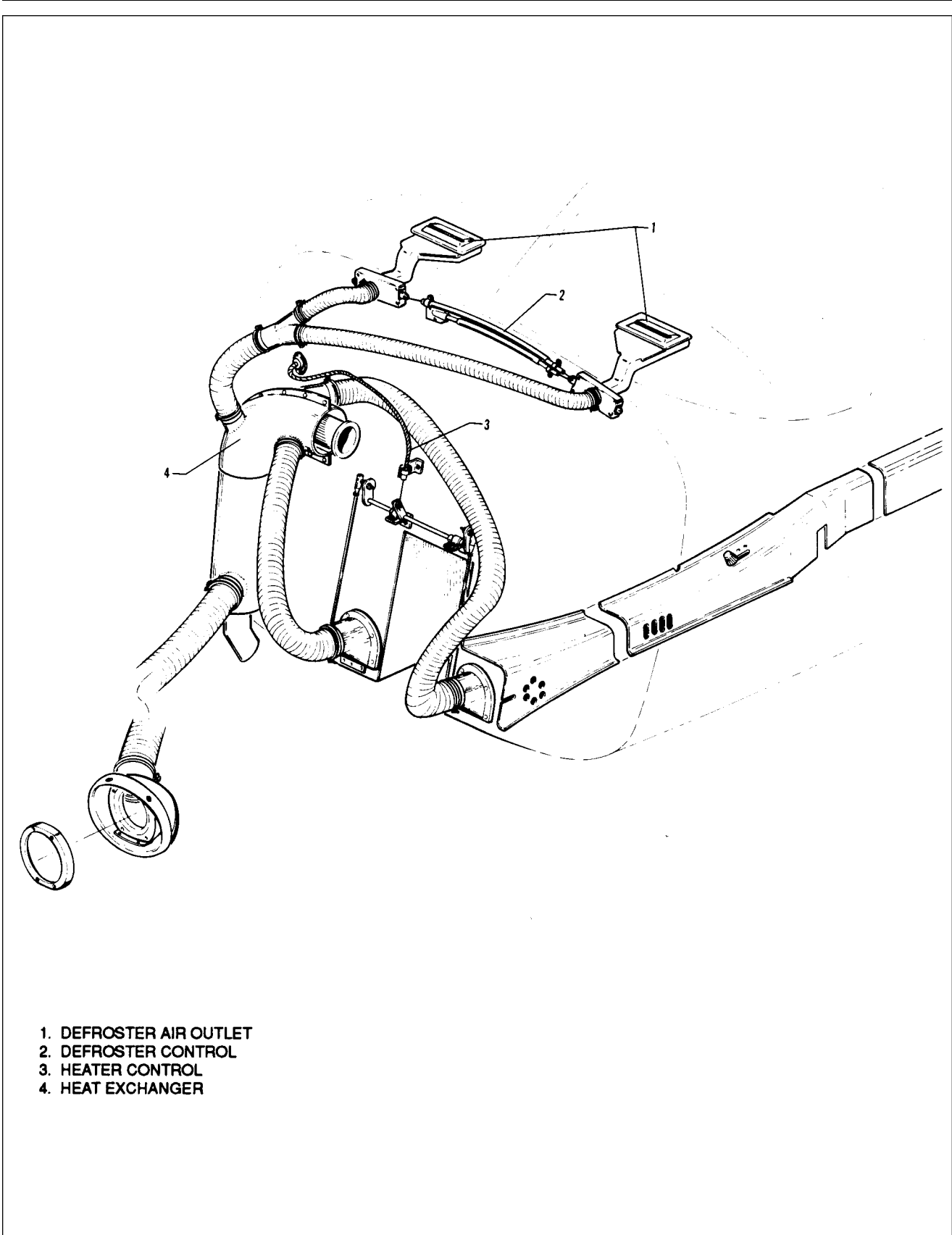

Figure 13-1. Cabin Heater and Defroster (PA-28R-201)



- 1. DEFROSTER AIR OUTLET
- 2. DEFROSTER CONTROL
- 3. HEATER CONTROL
- 4. HEAT EXCHANGER

Figure 13-2. Cabin Heater and Defroster (PA-28R-201T)

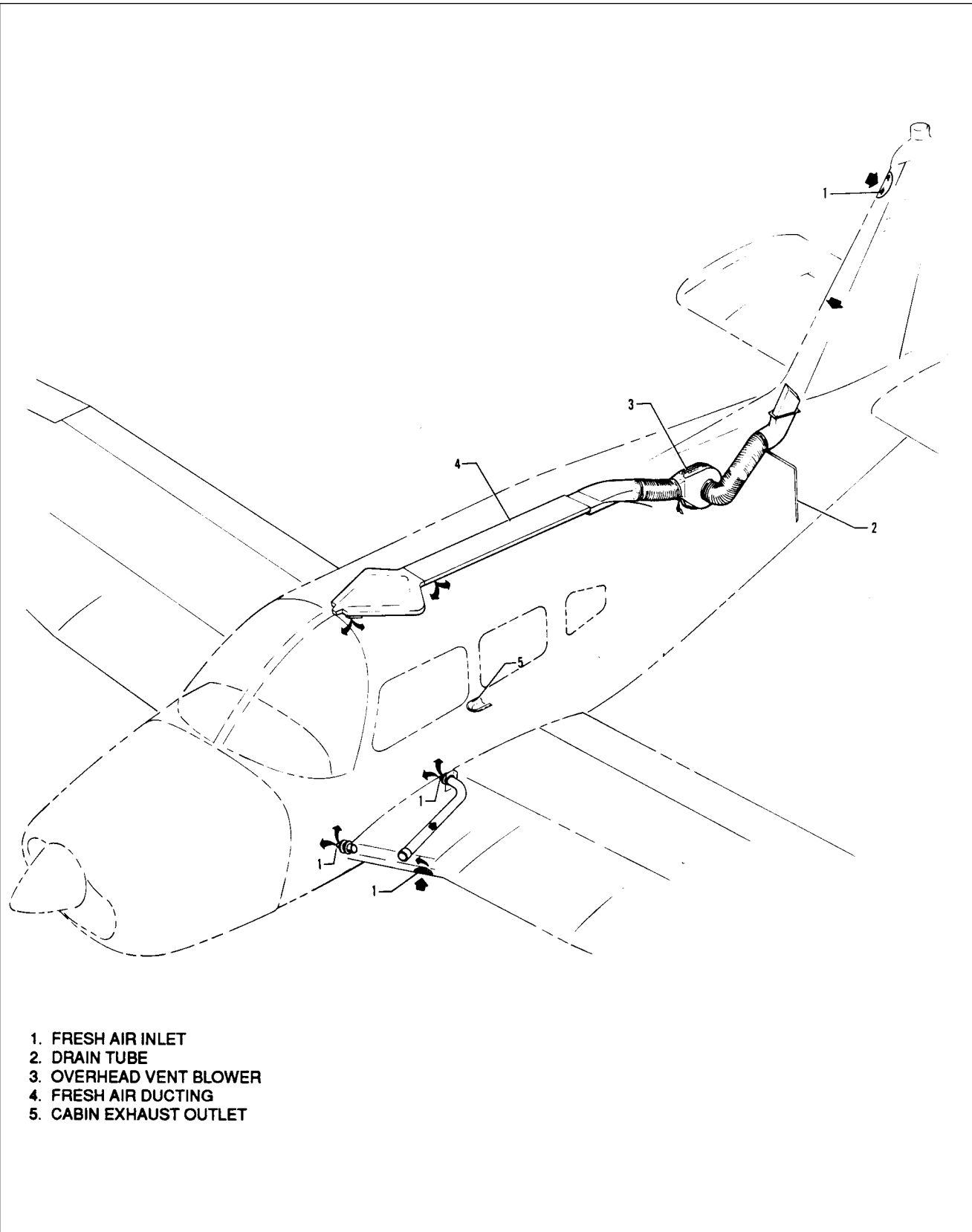
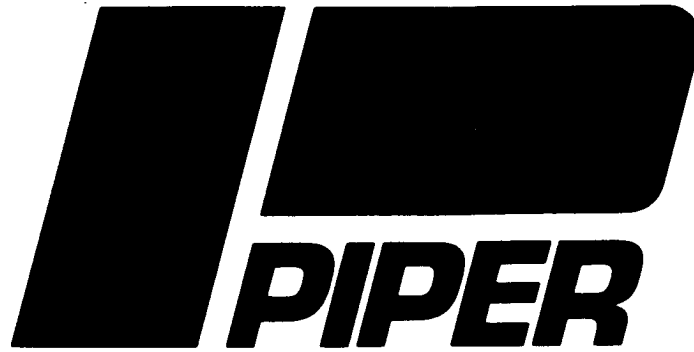

Figure 13-3. Overhead Vent System and Fresh Air System
"NOT AVAILABLE WITH AIR CONDITIONING"

**INTENTIONALLY LEFT BLANK
2K10 THRU 2L24**



ARROW III - TURBO ARROW III
ARROW

SERVICE MANUAL

CARD 3 OF 3

PA 28R-201/201T

Courtesy of Bomar Flying Service
www.bomar.biz

PIPER AIRCRAFT CORPORATION

(PART NUMBER 761 639)

3A1

CHEROKEE ARROW III SERVICE MANUAL

AEROFICHE EXPLANATION AND REVISION STATUS

Service manual information incorporated in this set of Aerofiche cards is arranged in accordance with the general specifications of Aerofiche adopted by the General Aviation Manufacturer's Association. Information compiled in this Aerofiche service manual is kept current by revision distributed periodically. These revisions supersede all previous revisions and are complete Aerofiche card replacements and supersede Aerofiche cards of the same number in the set.

Identification of revised material:

Revised text and illustrations are indicated by a black vertical line along the left-hand margin of the frame, opposite revised, or added material. Revision lines indicate only current revisions with changes and additions to existing text and illustrations. Changes in capitalization, spelling, punctuation, indexing, the physical location of the material, or complete page additions are not identified by revision lines.

Revisions to Service Manual 761 639 issued December 15, 1976 are as follows:

Effectivity	Publication Date	Aerofiche Card Effectivity
ORG761215	December 15, 1976	1 and 2
PR770831	August 31, 1977	1 and 2
PR781211	December 11, 1978	1 and 2
PR800501	May 1, 1980	1 and 2
PR801121	November 21, 1980	1 and 2
PR810713	July 13, 1981	1 and 2
PR831018	October 18, 1983	1 and 2
IR860730	July 30, 1986	1
IR860920	September 20, 1986	1
IR870506	July 12, 1987	1
PR890213	August 1, 1989	1, 2 and 3

Consult the latest Customer Services Information Aerofiche for current revision dates for this manual.

TABLE OF CONTENTS

NO.	AEROFICHE CARD NO. 1	GRID NO.
I	INTRODUCTION	1A13
II	HANDLING AND SERVICING	1A16
III	INSPECTION	1D1
IV	STRUCTURES	1D17
V	SURFACE CONTROLS	1F6
VI	HYDRAULIC SYSTEM	1H5
VII	LANDING GEAR AND BRAKE SYSTEM	1I22
AEROFICHE CARD NO. 2		
VIII	POWER PLANT (CONTINENTAL)	2A9
VIIIA	POWER PLANT (LYCOMING)	2C18
IX	FUEL SYSTEM	2E8
X	INSTRUMENTS	2F5
XI	ELECTRICAL SYSTEM	2G15
XII	ELECTRONICS	2J19
XIII	HEATING AND VENTILATING	2K5
AEROFICHE CARD NO. 3		
XIV	ACCESSORIES AND UTILITIES	3A5

LIST OF ILLUSTRATIONS (cont.)

Figure		Aerofiche Grid No.
14-1.	Air Conditioning System Installation.....	3A8
14-2.	Service Valves	3A12
14-3.	Test Gauge and Manifold Set	3A13
14-4.	Manifold Set Operation.....	3A14
14-5.	Leak Test Hook-Up	3A15
14-6.	Evacuation Hook-Up.....	3A17
14-7.	Charging Stand.....	3A19
14-8.	Charging Hook-Up.....	3A20
14-8a.	Top Dead Center Casting Mark (Sankyo Compressor).....	3B1
14-8b.	Rotation of Clutch Front Plate (Sankyo Compressor Oil Check)	3B1
14-9.	York Compressor and Fabricated Oil Dipstick (PA-28R-201).....	3B2
14-9a.	Compressor and Alternator Belt Installation.....	3B3
14-10.	Magnetic Clutch (York Compressor).....	3B6
14-11.	Condenser Air Scoop Installation.....	3B9
14-12.	Expansion Valve.....	3B10
14-13.	Components Installation.....	3B12
14-14.	Adjustment of Air Conditioning Throttle Switch (PA-28R-201).....	3B13
14-15.	Air Conditioning Wiring Schematic.....	3B14
14-16.	Oxygen Installation	3C2
14-17.	Test Apparatus for Testing Oxygen System.....	3C3
14-18.	Oxygen Tubing Installations.....	3C4
14-19.	Installation of Swageloc Fittings.....	3C7
14-20.	Portable Oxygen Installation.....	3C14

LIST OF TABLES

Table		Aerofiche Grid No.
XIV-I.	Temperature Pressure Chart.....	3A9
XIV-II.	Aluminum Tubing Torque.....	3A12
XIV-III.	Compressor Oil Charge.....	3A24
XIV-IV.	Troubleshooting Chart (Air Conditioner).....	3B16
XIV-V.	Blower System Wire Color Codes.....	3B23
XIV-VI.	Oxygen System Component Limits.....	3C15
XIV-VII.	Troubleshooting Chart (Oxygen System).....	3C17

LIST OF CHARTS

Chart		Aerofiche Grid No.
VIII-III.	Oxygen System Limits.....	3C8
VIII-IV.	Filling Pressure for Certain Ambient Temperatures.....	3C13

SECTION XIV

ACCESSORIES AND UTILITIES

Paragraph	Aerofiche Grid No.
14-1. Air Conditioning Installation.....	3A4
14-2. Description	3A4
14-3. Air Conditioning System Operation.....	3A4
14-4. Malfunction Procedures.....	3A7
14-5. Special Servicing Procedures.....	3A8
14-6. Service Valves	3A9
14-7. Service Valves Replacement.....	3A10
14-8. Test Gauge and Manifold Set	3A10
14-9. Checking the System for Leaks.....	3A12
14-10. Leak Check - Method I.....	3A12
14-11. Leak Check - Method II	3A13
14-12. Discharging.....	3A13
14-13. Evacuating the System	3A14
14-14. Charging the System.....	3A15
14-15. With a Charging Stand.....	3A15
14-16. Using the Airplane Compressor to Charge the System.....	3A16
14-17. Addition of Partial Charge to System.....	3A18
14-18. Compressor Service.....	3A18
14-19. Compressor Removal	3A19
14-20. Compressor Installation.....	3A19
14-21. Checking Compressor Oil	3A20
14-22. Replacement of York Compressor and/or Alternator Drive Belts.....	3A21
14-23. Adjustment of Drive Belt Tension.....	3B2
14-24. Magnetic Clutch (York Compressor).....	3B3
14-25. Magnetic Clutch Removal.....	3B3
14-26. Magnetic Clutch Installation	3B3
14-27. Refrigerant Lines and Routing	3B4
14-28. Receiver-Dehydrator	3B4
14-29. Receiver-Dehydrator Removal.....	3B4
14-30. Receiver-Dehydrator Installation	3B4
14-31. Condenser.....	3B5
14-32. Condenser Assembly Removal.....	3B5
14-33. Condenser Installation.....	3B5
14-34. Condenser Door Actuator.....	3B5
14-35. Condenser Assembly Rigging Instructions	3B5
14-36. Expansion Valve.....	3B7
14-37. Expansion Valve Removal.....	3B7
14-38. Expansion Valve Installation.....	3B7
14-39. Evaporator Assembly	3B8
14-40. Evaporator Assembly Removal.....	3B8

Paragraph	Aerofiche Grid No.
14-41. Evaporator Assembly Installation.....	3B8
14-42. Pressure Relief Switch (Ranco).....	3B9
14-43. Electrical Installation.....	3B9
14-44. Air Conditioning Throttle Switch.....	3B9
14-45. Fuse Replacement.....	3B9
14-46. Shoulder Harness Inertia Reel Adjustment	3B10
14-47. Overhead Vent Blower	3B10
14-48. Description	3B10
14-49. Removal of Blower Assembly.....	3B12
14-50. Disassembly of Blower Assembly.....	3B12
14-51. Reassembly of Blower Assembly.....	3B12
14-52. Installation of Blower Assembly.....	3B12
14-53. Oxygen System.....	3B21
14-54. Description and Operation.....	3B21
14-55. Troubleshooting.....	3B22
14-56. Fixed Oxygen System.....	3B22
14-57. Inspection and Maintenance.....	3B22
14-58. Cleaning and Purging of Oxygen System Components	3C2
14-59. Swageloc Fitting Installation.....	3C3
14-60. Application of Teflon Tape Thread Sealant.....	3C5
14-61. Leak Tests.....	3C6
14-62. Oxygen System Component Handling.....	3C6
14-63. Removal of Oxygen Cylinder.....	3C6
14-64. Removal of Recharge Valve.....	3C7
14-65. Installation of Recharge Valve.....	3C7
14-66. Installation of Oxygen Cylinder.....	3C8
14-67. Removal and Installation of Pressure Gauge.....	3C8
14-68. Removal of Outlets.....	3C9
14-70. Removal and Installation of Oxygen On/Off Control.....	3C9
14-71. Refilling Oxygen System	3C9
14-72. Portable Oxygen System	3C11
14-73. Description and Operation.....	3C11
14-74. Troubleshooting.....	3C11
14-75. Removal of Oxygen Unit.....	3C12
14-76. Inspection and Overhaul Times.....	3C12
14-77. Testing for Leaks.....	3C12
14-78. Maintenance	3C13
14-79. Removal of Outlets.....	3C13
14-80. Installation of Outlets.....	3C13
14-81. Purging Oxygen System.....	3C13
14-82. Cleaning of Face Masks	3C13

CHEROKEE ARROW III SERVICE MANUAL

SECTION XIV

ACCESSORIES AND UTILITIES

PA-28R-201 & PA-28R-201T

14-1. AIR CONDITIONING INSTALLATION.

14-2. DESCRIPTION. These installations consist of a compressor with its special bracketry, an evaporator, a condenser, a receiver-dehydrator, circulating fan, thermal expansion valve, and related plumbing.

The evaporator filters, dehumidifies and cools the air. The evaporator is mounted in a fabricated housing along with the receiver-dehydrator, circulating fan, thermal expansion valve and related plumbing. This housing is located at the rear of the cabin, aft of the baggage area. The compressor is a piston type unit which is supported by special bracketry at the front of the engine on PA-28R-201 and at the rear of the engine on PA-28R-201T models. A V-belt connection drives the compressor through a magnetic clutch (refer to Figure 14-1). The condenser is installed on a hinge mounted door that is located on the bottom portion of the fuselage tail section. The condenser door is mounted to allow extension into the airstream during system operation. The condenser door is electrically activated to provide the following positions (system on-fully extended or system off-fully retracted).

The system is protected by a Ranco type pressure switch which automatically controls the condenser maximum head pressures by temporarily de-clutching the compressor in the event the pressure becomes excessively high. The controls are located on the aircraft instrument panel adjacent to the heater and defroster levers, and consist of an Air Conditioning ON-OFF control, a three position fan control (LOW-MED-HIGH) to govern the cold air velocity, and a temperature control.

The system design is such that there is no increase in drag to the aircraft during its takeoff flight conditions. During maximum power demands, the compressor is de-clutched and the condenser door is automatically retracted.

14-3. AIR CONDITIONING SYSTEM OPERATION. The air conditioning system in these airplanes are a recirculating, independent unit. Its filters dehumidifies and cools the air as it cycles through the evaporator. The unit is operated from controls mounted on the right side of the instrument panel. The air conditioning master switch has three positions: FAN only, OFF and AIR COND. When the AIR COND position is selected the compressor clutch engages, the condenser scoop opens and the circulating fan is turned on. The temperature is controlled by a thermostat operated by the temperature control selector. A three position fan switch (LOW-MED-HIGH) operated the blower. The fan may be operated to circulate air without using the air conditioning unit.

The air conditioning system uses Refrigerant 12 as the refrigerant. The refrigerant enters the compressor as a vapor. The compressor pressurizes the heat-laden vapor until its pressure and heat reach a point much hotter than the outside air. The compressor then pumps the vapor to the condenser where it cools and changes to a liquid. The liquid then passes to the receiver-dehydrator. Its function is to filter, remove any moisture and ensure a steady flow of liquid refrigerant into the evaporator through the expansion valve. The expansion valve is a temperature controlled metering valve which regulates the flow of the liquid refrigerant to the evaporator. The evaporator absorbs the heat from the air passing over the coils. From the evaporator the refrigerant vapor returns to the compressor where the cycle is repeated.

NOTE

A table at the end of these instructions will assist in locating and correcting malfunctions which may arise in this system.

CHEROKEE ARROW III SERVICE MANUAL

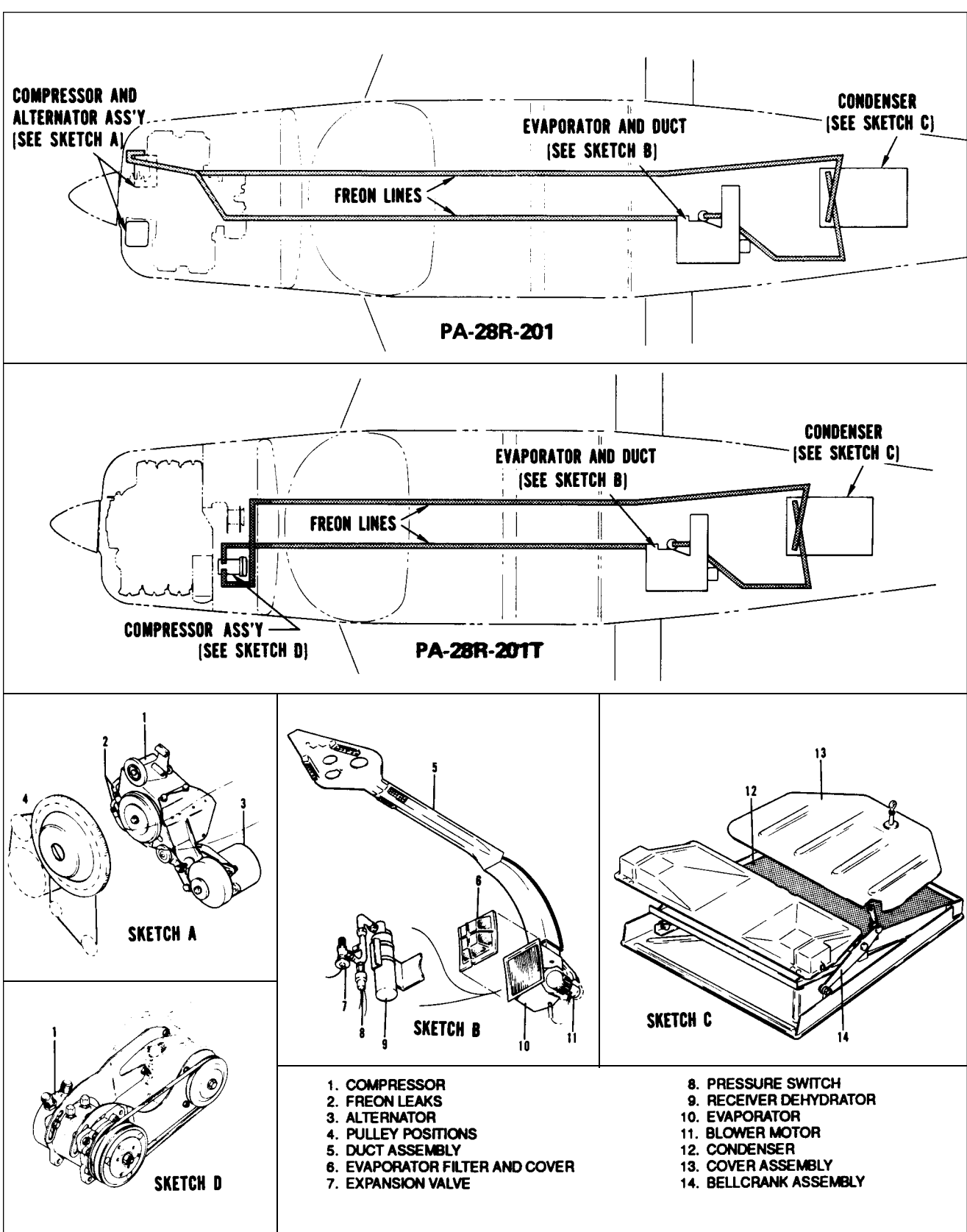

Figure 14-1. Air Conditioning System Installation

CHEROKEE ARROW III SERVICE MANUAL

TABLE XIV-I. TEMPERATURE PRESSURE CHART

Evaporator Pressure Gauge Reading psi	Evaporator Temperature °F.	High Pressure Gauge Reading psi	Ambient Temperature °F.
0	-21	72	40
2.4	-15	86	50
4.5	-10	105	60
10.1	2	109	62
11.2	4	113	64
12.3	6	117	66
13.4	8	122	68
14.6	10	126	70
15.8	12	129	71
17.1	14	132	72
18.3	16	134	73
19.7	18	137	74
21	20	140	75
22.4	22	144	76
23.1	23	148	77
23.8	24	152	78
24.6	25	156	79
25.3	26	160	80
26.1	27	162	81
26.8	28	165	82
27.6	29	167	83
28.4	30	170	84
29.2	31	172	85
30	32	175	86
30.9	33	177	87
31.7	34	180	88
32.5	35	182	89
33.4	36	185	90
34.3	37	187	91
35.1	38	189	92
36	39	191	93
36.9	40	193	94
37.9	41	195	95
38.8	42	200	96
39.7	43	205	97
41.7	45	210	98
43.6	47	215	99
45.6	49	220	100
48.7	52	228	102
49.8	53	236	104
55.4	57	260	110
60	62	275	115
64.9	66	290	120

CHEROKEE ARROW III SERVICE MANUAL

NOTE

The air conditioning system should be operated at least once a month to prevent sticking valves and keep the system lubricated.

14-4. MALFUNCTION DETECTION. The detection of system malfunction largely depends on the mechanic's ability to interpret the gauge pressure readings into system problems. A system operating normally will have a low side gauge pressure reading that will correspond with the temperature of the refrigerant evaporating in the evaporator, allowing for a few degrees temperature rise due to loss in the tube walls and fins. The high side will have a gauge pressure that will correspond with the temperature of the refrigerant condensing in the condenser, allowing for a few degrees temperature drop due to loss in the tube walls and fins.

Any deviation from that which is normal indicates a malfunction within the system due to a faulty control device, obstruction, defective part, or improper installation.

Detection of system malfunction is made easier with the knowledge that the temperature and pressure of Refrigerant 12 is in close proximity between the pressures of twenty and eighty pounds per square inch (psi). A glance at the temperature-pressure chart will show that there is only a slight variation between the temperature and pressure of the refrigerant in the lower range.

It is correct to assume that for every pound of pressure added to the low side, a temperature increase of about one degree Fahrenheit takes place. For instance, a pressure of 23.8 on the chart indicates a temperature of 24°F. A change of pressure of almost one pound to 24.6 psi gives us a temperature increase to 25°F.

NOTE

For each 1,000 feet of elevation above sea level, the gauge readings will be about one inch of mercury or 1/2 psi higher than the chart indicates.

It must be pointed out that the actual temperature of the air passing over the coils of the evaporator will be several degrees warmer allowing for a temperature rise caused by the loss in the fins and tubing of the evaporator.

The importance of a seasonal check up of the air conditioning system should be brought to the attention of the customer whenever possible. A thorough check of the system performed in a methodical manner will reveal trouble the customer is often not aware of. Locating and repairing the trouble early will usually result in savings to the customer both in time and additional troubles that too often result from neglect.

A Performance Test of the system is the only positive way in which the complete system can be checked for efficient operation. The air conditioning system should be given this test before work is begun on the system whenever possible, however, if the system is completely inoperative, repairs must be performed before the system can be properly tested. The test can uncover further work that must be performed before the system is brought to its full operating efficiency. The Performance Test should always be performed after repair work has been done and before the aircraft is released to the customer. The serviceman performing this test carefully will ensure that the repairs have been properly performed and that the system will operate satisfactorily.

The Performance Test, when properly performed, includes a thorough examination of the outside of the system as well as the inside. Many related parts are overlooked because it is felt they are of no bearing on the operating efficiency of the unit. For this reason, a thorough visual inspection of the complete system should be performed, followed by an operating inspection of the system.

CHEROKEE ARROW III SERVICE MANUAL

14-5. SPECIAL SERVICING PROCEDURES. The air conditioning system should be serviced by a qualified shop with trained personnel. The following procedure and precautions should be observed.

The efficiency of this system depends upon the pressure-temperature relationship of pure refrigerant. As long as the system contains only pure refrigerant plus a specified amount of compressor oil (which is mixed with the refrigerant) it is considered to be chemically stable. Foreign materials within the system will affect the chemical stability, contaminate the system, and decrease its efficiency.

I. GENERAL REFRIGERATION SYSTEM PROCEDURES.

A. REFRIGERANT SAFETY PRECAUTIONS.

1. Refrigerant 12 (commonly known as R-12 or Freon 12) is odorless and colorless in either the liquid or gaseous state. R-12 for charging refrigeration systems is supplied in pressurized containers (approx. 70 psi at 70°F) in liquid form. Since this material is essentially inert at room temperatures, the dangers are primarily associated with the pressure and the refrigeration effects of the release and subsequent evaporation of this pressurized liquid.
2. Wear suitable eye protection when handling R-12 due to the possibility of freezing of the eye if contacted by escaping liquid refrigerant. If liquid R-12 does strike the eye, the following action should be taken.
 - a. DO NOT RUB THE EYE.
 - b. Splash large quantities of cool water into the eye to raise the temperature.
 - c. Tape on an eye patch to avoid the possibility of dirt entering the eye.
 - d. Rush to a physician or hospital for immediate professional aid.
 - e. DO NOT ATTEMPT TO TREAT IT YOURSELF.
3. If liquid R-12 strikes the skin, frostbite can occur. Treat with cool water and protect with petroleum jelly.
4. Do not discharge large quantities of R-12 into closed rooms. It may displace most of the air in the room and this could cause oxygen starvation. Gaseous R-12 is heavier than air and flows to the bottom of a container.
5. Do not discharge R-12 into an open flame or onto a very hot surface (500°F+). Poisonous phosgene gas is generated by the action of the heat on the refrigerant.
6. Do not apply direct flame or other high heat source to a R-12 container due to the high pressures which will result. If any heating is done to R-12 containers, the container pressure should be monitored and kept below 150 psi.

B. SYSTEM SERVICING PRECAUTIONS.

1. Systems should be discharged slowly to prevent the escape of liquid refrigerant and the loss of the lubricating oil.
2. Systems should not be left open to the atmosphere when discharged. Moisture and other contamination may enter and damage open systems.
3. Never introduce anything but pure refrigerant and refrigerant oil into a system.
4. Keep refrigerant oil containers tightly sealed and clean to prevent absorption of moisture or other contamination.
5. Use only approved refrigeration oil in the compressor. If any doubt exists about the cleanliness of the compressor oil, replace it with new oil.
6. Never reuse oil removed from the system. Discard it.
7. When Loctite Refrigerant Sealant has been used on a joint it must be heated to 400°F prior to disassembly. Loctite must be used to seal any pipe threads in the system lines.
8. Replace the receiver-dehydrator assembly on any system which has been operating with a leak allowing air to enter the system. If a receiver-dehydrator is left open to the atmosphere it should be replaced due to the loss of effectiveness of the drying compound it contains.

CHEROKEE ARROW III SERVICE MANUAL

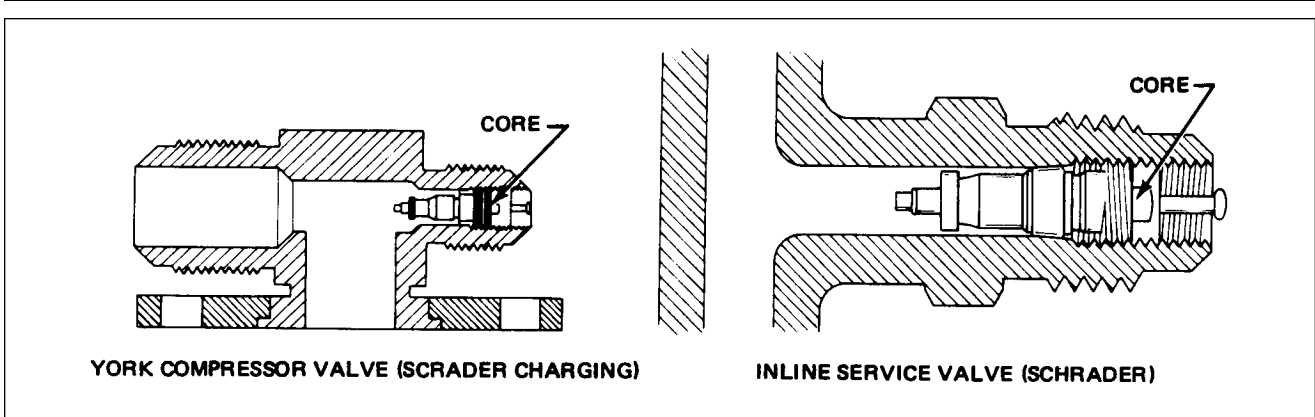

Figure 14-2. Service Valves

NOTE

A very strong acid (HCL) is formed when R-12 comes in contact with moisture.

A new receiver-dehydrator should be opened and connected to the system only when ready to charge the system with refrigerant.

9. Recommended torque values must be used on all flare fitting and O-ring joints. See Table XIV-II.

TABLE XIV-II. ALUMINUM TUBING TORQUE

Metal Tube O.D	Thread and Fitting Size	Alum. Tubing Torque
1/4	7/16	5-7 ft.-lbs.
3/8	5/8	11-13 ft.-lbs.
1/2	3/4	15-20 ft.-lbs.
5/8	7/8	21-27 ft.-lbs.
3/4	1-1/16	28-33 ft.-lbs.

14-6. SERVICE VALVES. The purpose of the service valve is to service the air conditioning system (Testing, Bleeding, Evacuating and Charging). This aircraft is equipped with service valves mounted in the suction and discharge lines of the evaporator assembly. These valves are the “2” position type Schrader valves. All normal air conditioning service should be performed at the evaporator assembly mounted valves.

NOTE

Service valves are also located on the compressor. However, use of these valves in servicing is not recommended.

NOTE

If a Schrader service valve is not serviceable, the core assembly must be replaced.

CHEROKEE ARROW III SERVICE MANUAL

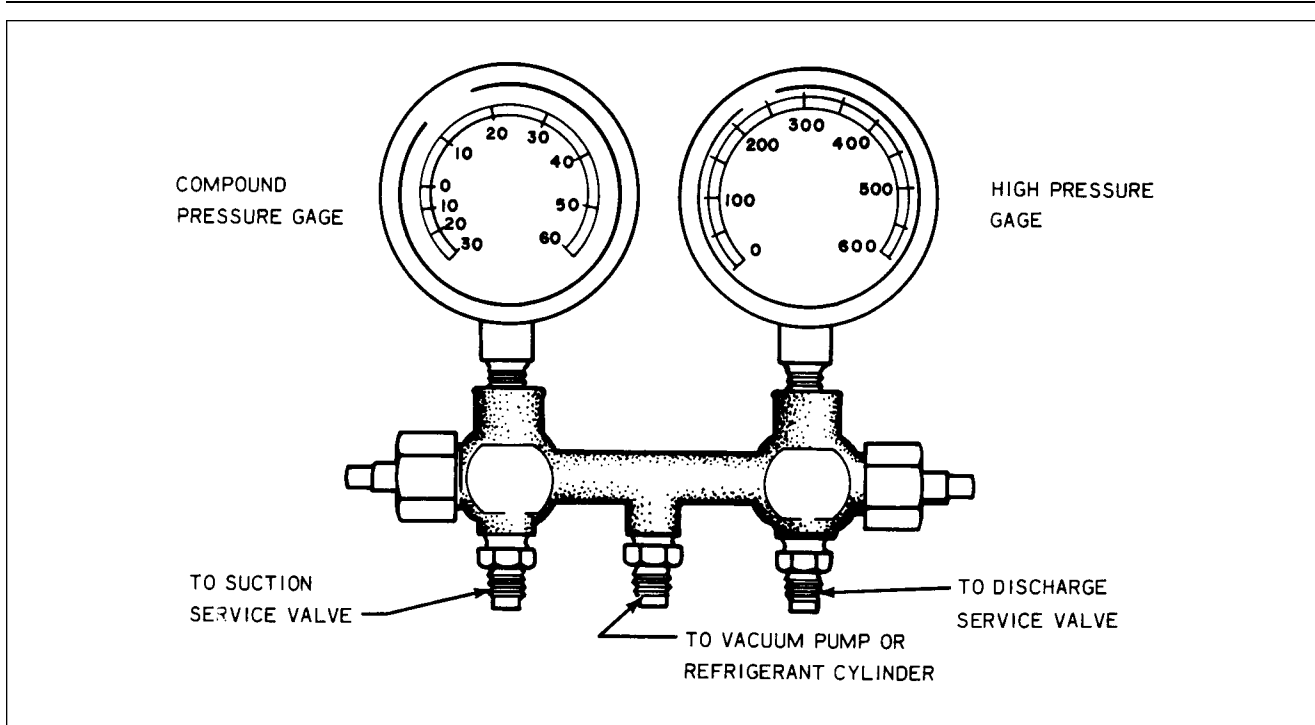

Figure 14-3. Test Gauge and Manifold Set

14-7. SERVICE VALVE REPLACEMENT. The valves on the York compressor are sealed with a gasket placed in the valve port boss. Lubricate the gasket with refrigerant oil of the type used in the compressor, place the valves with the tube fitting aft and secure with .312 bolts, torque to 15-23 inch pounds.

NOTE

Whenever the air conditioning refrigerant lines or system is opened for any reason, the lines and fittings should be capped and sealed immediately to prevent dirt and other contaminants from entering the system. (It is not advisable to put a plug into the hoses or fittings.)

14-8. TEST GAUGE AND MANIFOLD SET. The proper testing and diagnosis of the air conditioning system require that a manifold gauge set be attached into the system. This set consists of two gauges mounted to a manifold. One gauge is a high pressure gauge used in the discharge side of the system. The other is a low pressure gauge used in the suction side of the system. The manifold is a device having fittings for both gauges and connection hoses with provisions for controlling the flow of refrigerant through the manifold. See Figures 14-3 and 14-4.

The center port of the manifold set is used for charging or evacuation procedures, or any other service that may be necessary.

Both the high and low side of the manifold have hand shutoff valves. When the hand valve is turned all the way in, in a clockwise direction, the manifold is closed. The pressures on the side of the system will, however, be recorded on the gauge above the hose.

Cracking the hand valve, in the counterclockwise direction, opens the system to the middle service port of the manifold set. This is desirable only when it is necessary to let refrigerant out or into the system. Refer to Figures 14-3 and 14-4.

CHEROKEE ARROW III SERVICE MANUAL

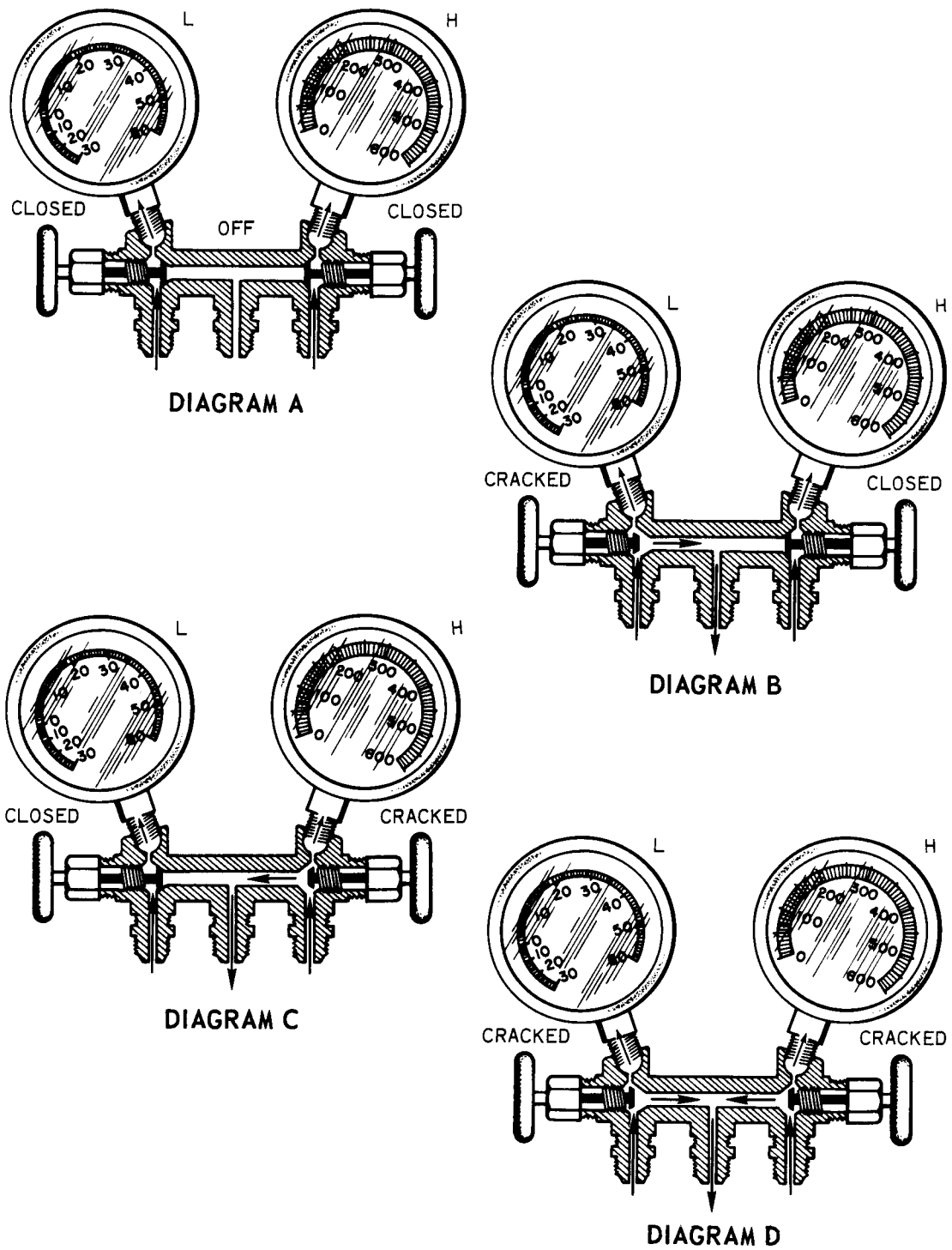

Figure 14-4. Manifold Set Operation

CHEROKEE ARROW III SERVICE MANUAL

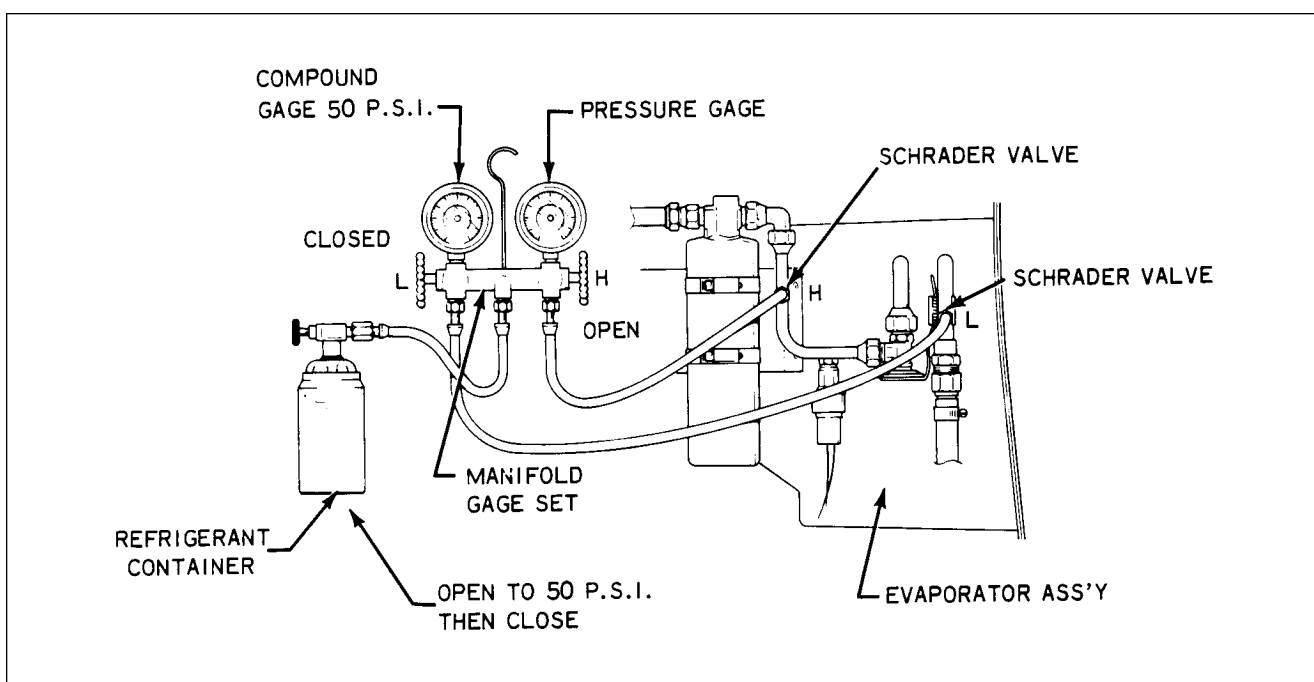

Figure 14-5. Leak Test Hookup

14-9. CHECKING THE SYSTEM FOR LEAKS. There are several methods of doing this operation, depending on the type of equipment which is available. Two methods of performing this check will be covered in the following paragraphs.

NOTE

Evacuate system prior to leak check.

14-10. LEAK CHECK - METHOD I.

- Connect the manifold gauge set into the system and determine if there is any refrigerant in the system. A minimum of 50 psi refrigerant pressure in the system is needed for leak detection. (Refer to Figure 14-5.)
- Purge the hoses of air by allowing some refrigerant to escape from the connections at the service valves. Then tighten connections at the service valve.
- Close the low side manifold valve and open the high side manifold valve.
- Open the refrigerant container service valve and allow the pressure at the low side gauge to reach 50 psi at which time close the high side manifold valve.
- Close the refrigerant container service valve and remove the hose if no leaks are evident.
- It is advisable to use an electronic leak detector to check this system instead of an open flame leak detector due to the possible presence of gasoline fumes in the engine area.
- If any leaks are found, purge the system of refrigerant, make the necessary repairs and check the compressor oil.
- Add oil, if required, (refer to paragraph 14-21 and Table XIV-II) then repeat steps a. thru e.
- If no further leaks are found, the system may be evacuated and charged. Refer to paragraphs 14-13 and 14-14.

CHEROKEE ARROW III SERVICE MANUAL

14-11. LEAK CHECK - METHOD II.

- a. Remove the access panel at the rear of the cabin to gain access to the service valves.
- b. Remove the protective cap on the high pressure Schrader valve fitting and connect a charging hose with a shutoff valve arrangement to the fitting. The charging hose must have a Schrader fitting or adapter to fit the valve.
- c. Connect the other end of the charging hose to a small cylinder or refrigerant and purge the hose by allowing a slight amount of refrigerant gas to escape from the Schrader valve fitting.
- d. The cylinder of refrigerant should be placed upright in a container of warm (125°F max.) water on a small scale.
- e. Allow approximately 1/2 pound of refrigerant to enter the system by opening the valve on the charging hose and observing the weight change on the scale.
- f. Using an electronic leak detector, check all joints and repair any leaks.
- g. After completion of repair of any leaks, proceed to check the system in accordance with one of the methods outlined for any other leaks.
- h. If no further repair is required on the system, it is now ready to evacuate in accordance with paragraph 14-13.

14-12. DISCHARGING. (Required only if system contains refrigerant.)

NOTE

Applies to Kent Moore J23500 or similar charging station. Refer to Figure 14-7.

- a. Close all valves on charging station.
- b. Connect red high pressure charging line to high pressure Schrader valve at the evaporator fitting.
- c. Open valve 8 (high pressure control) on charging station one turn.
- d. Hold end of blue low pressure charging line in a stop rag and slowly open valve 2 (low pressure control) on charging station allowing refrigerant to exhaust from system into shop rag.

CAUTION

Refrigerant can cause freezing of skin. Be particularly careful not to allow contact with the eyes.

Do not allow refrigerant to escape too rapidly, as excessive oil may be carried out of system. When hissing stops, system is empty and valve should be closed if no further work is planned.

14-13. EVACUATING THE SYSTEM. If the system has been operated in a discharged condition or anytime the system has been open to atmospheric pressure, the receiver-dehydrator must be replaced and the system evacuated to remove any trapped air and moisture which has entered it. A vacuum pump capable of pulling 29 inches of mercury or better should be used. As we lower the pressure in the air conditioning system, we lower the boiling temperature of the water (moisture) that may be present. Then we are able to pull this water, in the form of vapor, out of the system. The following table demonstrates the effectiveness of moisture removal under a given vacuum.

CHEROKEE ARROW III SERVICE MANUAL

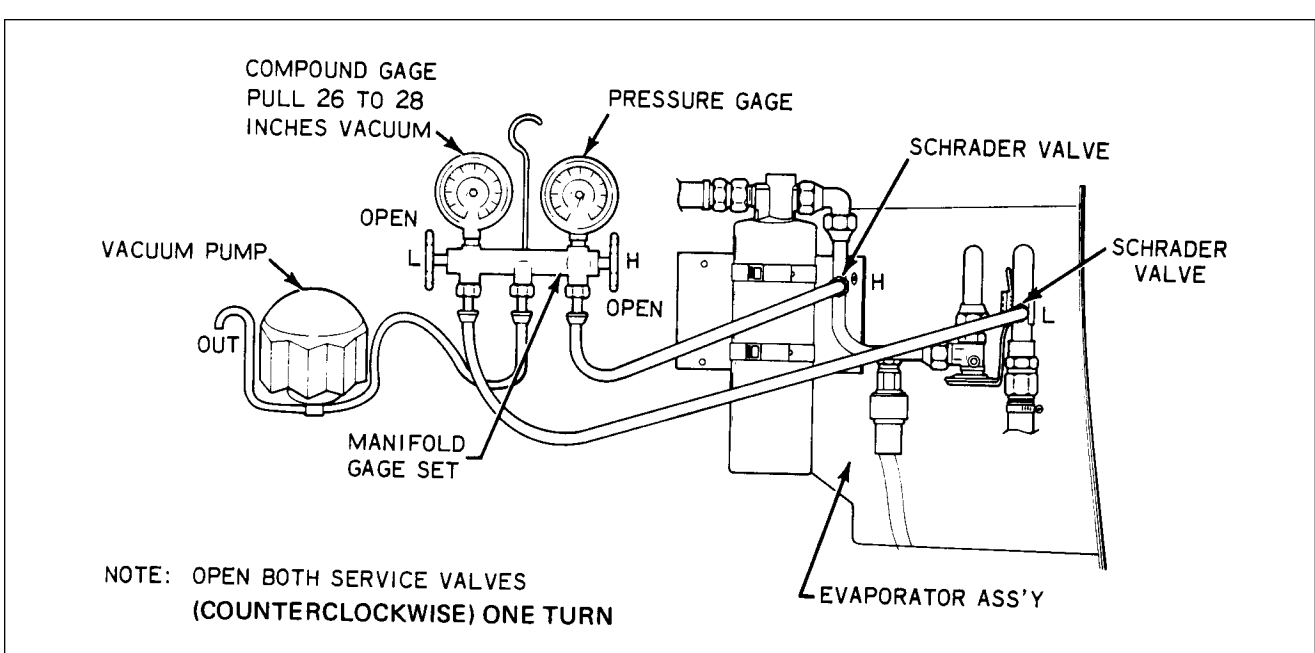

Figure 14-6. Evacuation Hookup

	System Vacuum	Temperature °F
COMPOUND GAUGE READING IN INCHES OF MERCURY VACUUM	27.99	100
	28.89	80
	29.40	60
	29.71	40
	29.82	20
	29.88	0

NOTE

For each 1,000 feet of elevation above sea level, the compound gauge reading will be about one inch lower, numerically.

The following steps should be of help when performing this operation.

- Remove access panel at the rear of the cabin to gain access to the Schrader service valves.

CAUTION

Ascertain that all system pressure is released before attempting the evacuation. (Refer to paragraph 14-5.)

CHEROKEE ARROW III SERVICE MANUAL

- b. Connect the manifold gauge set to the airplane service valves. (Refer to Figure 14-6.)
- c. The high and low manifold hand valves should be in the closed position. (Refer to Figure 14-3 and 14-4.)
- d. Connect the center manifold hose to the inlet of the vacuum pump.

NOTE

Make sure the exhaust port on the vacuum pump is open to avoid damage to the vacuum pump.

- e. Start the vacuum pump and open the low side manifold hand valve. Observe the compound, low pressure gauge needle, it should show a slight vacuum.
- f. Continue to operate the vacuum pump until 26 to 28 inches of vacuum is attained on the low pressure gauge, then extend the operation for another 25 minutes.
- g. If the system cannot maintain 26 to 28 inches of vacuum, close both manifold hand valves and observe the compound gauge.
- h. Should the compound gauge show a loss of vacuum, there is a leak in the system which must be repaired before continuing with evacuation.
- i. If no leaks are evident, reopen both manifold hand valves and continue the evacuation for another 30 minutes.
- j. Close both manifold hand valves, stop vacuum pump and disconnect center manifold hose from the vacuum pump.
- k. Proceed to charge the system in accordance with paragraph 14-14.

NOTE

The system should be charged as soon as it has been evacuated.

14-14. CHARGING THE SYSTEM. When the system is completely evacuated in accordance with instructions given in paragraph 14-13, one of the following procedures should be used to charge the system.

14-15. WITH A CHARGING STAND. This is the preferred method of charging the system.

NOTE

The following instructions apply to Kent Moore, J23500 charging stand. Refer to Figure 14-7.

- a. With the system discharged and evacuated, proceed to hook-up the charging stand. (Refer to Figure 14-8.)
- b. Fill the charging cylinder by opening the valve at the base of the charging cylinder and filling the sight glass with two pounds of liquid refrigerant.
- c. As refrigerant stops filling the sight glass, open the valve at the top of the gauge neck assembly intermittently to relieve head pressure and allow refrigerant to continue filling the sight glass to the required amount.
- d. When refrigerant reaches the required level in the sight glass, close both the valve at the base of the cylinder and the valve at the bottom of refrigerant tank. Be sure the top valve is fully closed.

CHEROKEE ARROW III SERVICE MANUAL

1. CYLINDER PRESSURE GAUGE
2. COMPOUND VALVE
3. VALVE, LOW PRESSURE CONTROL
4. VALVE, VACUUM CONTROL
5. CHARGING CYLINDER
6. BRACKET
7. SIGHT GLASS
8. CYLINDER BASE VALVE
9. HIGH PRESSURE GAUGE
10. VALVE, HIGH PRESSURE CONTROL
11. VALVE, REFRIG. CONTROL
12. CHARGING LINE HOSE HOLDER
13. BRACKET
14. LOW PRESSURE CHARGING LINE
15. HIGH PRESSURE CHARGING LINE
16. HEATING ELEMENT PLUG
17. VACUUM PUMP
18. OIL FILL LOCATION
19. NECK ASSEMBLY
20. REFRIGERANT DRUM SUPPORT
21. REFRIGERANT DRUM VALVE
22. VACUUM PUMP VALVE
23. VACUUM PUMP EXHAUST PORT
24. TOP CYLINDER VALVE
25. REFRIGERANT DRUM
26. WEB STRAP
27. REFRIGERANT DRUM REDUCER
28. CHARGING CYLINDER HOSE
29. VACUUM PUMP INTAKE HOSE
30. VACUUM PUMP SWITCH
31. VACUUM PUMP POWER CORD

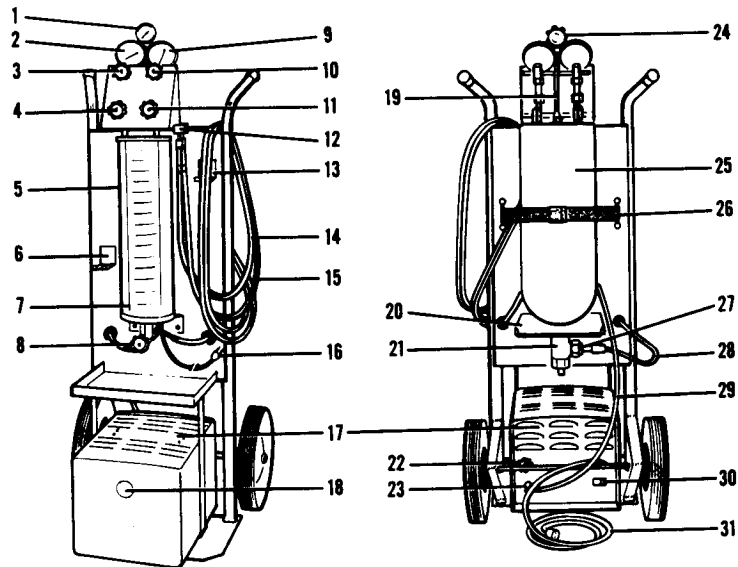

Figure 14-7. Charging Stand

NOTE

If bubbling occurs in sight glass, reopen the cylinder base valve momentarily to equalize drum and cylinder pressure.

- e. Connect the heating element plug to a 110-volt outlet.
- f. Turn cylinder sight glass to match pressure reading on cylinder pressure gauge. This scale should be used during entire charging operation.
- g. Close valve 1 (low pressure control), fully open valve 4 (refrigerant control) and allow all the liquid refrigerant contained in the charging cylinder to enter high side of aircraft system.
- h. When the full charge of refrigerant has entered the system, close valve 4 (refrigerant control) and valve 2 (high pressure control).
- i. After completion of charging, close all valves on the charging stand. Disconnect the high and low pressure charging lines from the aircraft system. (A small amount of refrigerant remaining in the lines will escape.) Replace lines on holder of charging stand to keep air and dirt out of lines. Open the valve at the top of cylinder to relieve any remaining pressure then reclose the valve.
- j. Reinstall protective caps of Schrader valves and any access panels previously removed.

14-16. USING THE AIRPLANE COMPRESSOR TO CHARGE THE SYSTEM. This method is the least desirable due to the requirement of operating the airplane's engine to run the compressor.

WARNING

If the air conditioner is to be operated during ground servicing, the test area should be clean and free of any loose objects lying on the ramp. Only the service valve located on the evaporator assembly should be used for testing.

CHEROKEE ARROW III SERVICE MANUAL

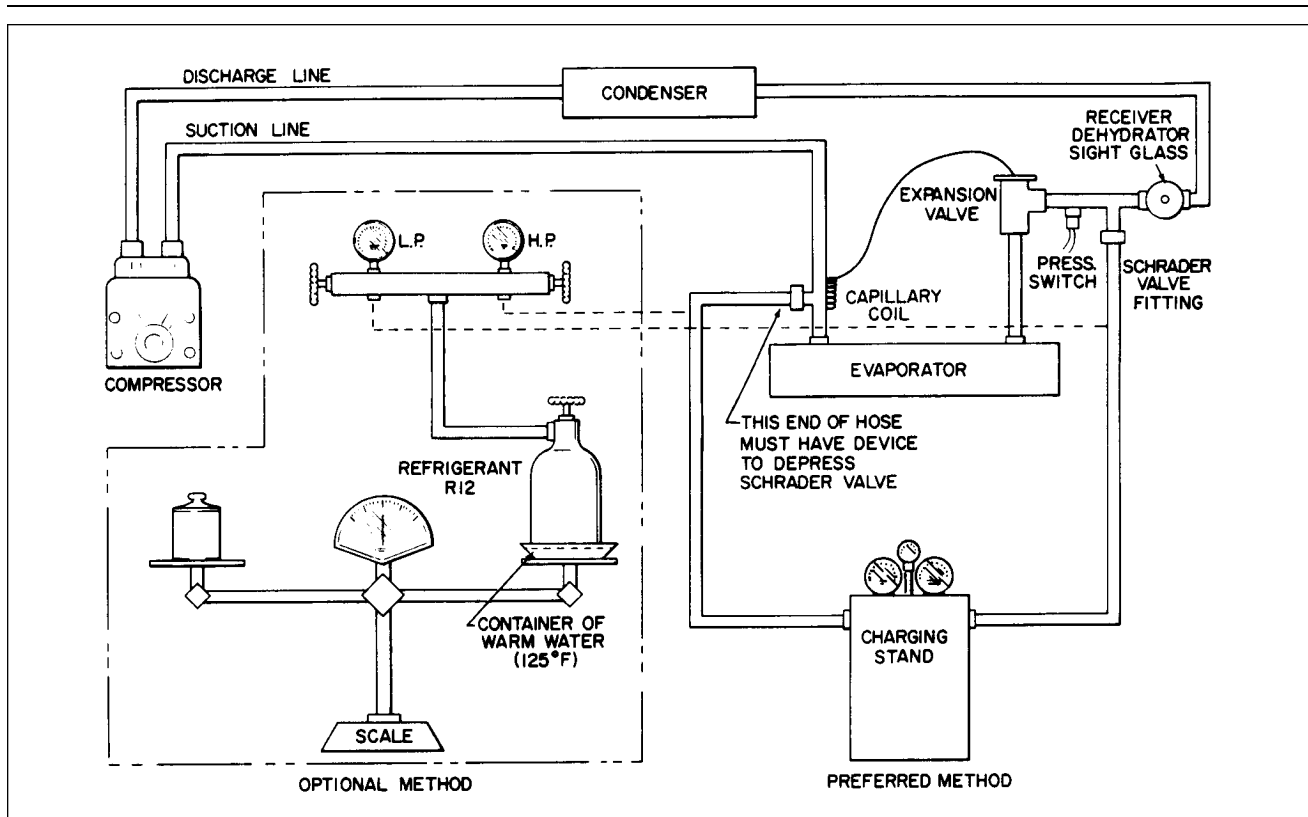

Figure 14-8. Charging Hookup

- With the system evacuated as outlined in paragraph 14-13, connect the refrigerant charging hose to the manifold (refer to Figure 14-8) and purge the charging hose of air.
- Place the refrigerant container on a scale to observe the amount of refrigerant entering the system. Open the high pressure valve and add as much refrigerant as possible.
- Close the high pressure valve, start the engine and operate it at 900 to 1000 rpm.
- Operate the air conditioner and set controls to maximum cooling.
- Open the low pressure valve and complete charging the system.
- Close the low pressure valve after two pounds of refrigerant has been added to the system.
- With the system still operating, observe the sight glass in the top of the receiver-dehydrator by removing the plastic plug.
- The sight glass should be clear of any bubbles or foam. If bubbles or foam are seen passing through the sight glass, it is an indication of a low refrigerant charge in the system and more refrigerant is required. This check should be made with OAT of 70°F or higher and with the air conditioner operating.
- If more refrigerant must be added to the system, open the low pressure valve and increase engine speed to 2000 rpm and observe the sight glass. After the sight glass has cleared, close the low pressure valve and observe the pressure gauges. At 1000 rpm, the gauge pressure should be 15 to 20 psi on the low side and 150 to 200 on the high side.

NOTE

Suspect leaks or an inaccurate scale if two pounds of refrigerant does not fill the system.

- Shut off the air conditioning system and airplane engine. Then, remove the charging lines from the Schrader valves with care due to the refrigerant remaining in the hose.

CHEROKEE ARROW III SERVICE MANUAL

NOTE

A shop cloth should be used to divert escaping refrigerant when disconnecting the charging hose from the Schrader valve. Recap the valve.

14-17. ADDITION OF PARTIAL CHARGE TO SYSTEM. It is possible to top off this system with refrigerant by the following method.

- a. Remove the access panel at the rear of the cabin.
- b. Connect a charging hose to a refrigerant cylinder and also to the Schrader valve fitting on the suction line. (Refer to Figure 14-8.)
- c. Purge the charging hose by allowing a small amount of refrigerant gas to escape at the Schrader valve fitting.
- d. Start the engine and operate at 1000 rpm and turn the air conditioner on maximum cool.
- e. Remove the plastic plug from the sight glass in the top of the receiver-dehydrator.
- f. With a low refrigerant charge in the system, bubbles will be seen passing thru the sight glass when the system is operating.
- g. Open the valve on the refrigerant cylinder.
- h. Allow refrigerant to flow into the system until the bubbles disappear from the sight glass.
- i. Close the refrigerant valve and check to see that the sight glass remains clear during system operation.
- j. When the sight glass stays clear of bubbles, add an additional 1/4 pound of refrigerant to the system. (Engine should be operating at 1000 rpm.)

NOTE

This should be done with OAT at 70°F, or higher, with the air conditioner operating.

- k. Shut off the air conditioner and engine. Remove the charging hose from the Schrader valve with care due to refrigerant remaining in the line.
 1. Replace the access panels.

14-18. COMPRESSOR SERVICE. It is not advisable to service the compressor in the field. It should be done by a qualified shop which has the special equipment and trained personnel required to properly service the unit.

Maintenance of the York unit and its related components is limited to the replacement of worn drive belt and magnetic clutch. Any other service requires removal of the compressor from the system. Maintenance to the Sankyo compressor is limited to replacement of worn drive belt. Contact Sankyo International, 3529 Miller Park Drive, P.O. Box 2903, Garland, Texas 75042 for special tools and instructions for detailed compressor maintenance.

NOTE

An important factor in air conditioning servicing is cleanliness and care should be exercised to prevent dirt or foreign material from entering the system. All hose and tubing ends should be capped immediately. Any lubrication required in the assembly of the components should be refrigerant oil of the type used in the compressor.

CHEROKEE ARROW III SERVICE MANUAL

14-19. COMPRESSOR REMOVAL. (The removal of the compressor requires a complete system discharge.)
See paragraph 14-12.

- a. The removal instructions for the York compressor are as follows:
 1. Be certain the circuit protector is off for the air conditioning system.
 2. Remove the engine cowling and right front baffles.
 3. Disconnect the electrical leads to the magnetic clutch on the compressor.
 4. Depressurize the air conditioning system.
 5. Remove the suction and discharge lines from the service valves on the compressor.

NOTE

All open lines should be capped immediately to prevent dirt and moisture from entering the system.

6. Loosen the bolt securing the compressor idler pulley to release the belt tension and remove belt from compressor pulley. (Do not force belt over the pulleys.)
7. Support the compressor and remove the six bolts securing the compressor to the engine mounting brackets.
- b. The removal instructions for the Sankyo compressor are as follows:
 1. Ascertain that air conditioning circuit protector is in the off position.
 2. Remove engine cowling.
 3. Disconnect the electrical leads to the magnetic clutch on the compressor.
 4. Depressurize the air conditioning system.
 5. Remove the suction and discharge line from the service valves on the compressor.

NOTE

All open lines should be capped immediately to prevent dirt and moisture from entering the system.

6. Loosen the four bolts securing the compressor in the mounting brackets. Rotate the compressor in the bracket slots to disconnect drive belt.
7. Support compressor and remove the attachment bolts.

14-20. COMPRESSOR INSTALLATION.

- a. The installation instructions for the York compressor are as follows:
 1. Place the compressor to the mounting brackets. Install the six bolts and progressively torque to 14-17 foot pounds. (Safety all bolts with .032 safety wire.)
 2. Check the oil level in the compressor in accordance with instructions given in paragraph 14-21.
 3. Place drive belt over clutch pulley and adjust the alignment of the pulleys and belt in accordance with instructions given in paragraph 14-22.

CAUTION

Do not force the belt into the pulley sheave. If necessary, remove the idler assembly.

4. Connect the discharge and suction lines to their respective service valve fittings.
5. Evacuate and charge the system per paragraphs 14-13 and 14-14.

CHEROKEE ARROW III SERVICE MANUAL

WARNING

If the air conditioner is to be operated on the ground for servicing, the test area should be clean and free of any loose objects lying on the ramp. Only the service valves located on the evaporator assembly should be used for testing.

- b. The installation instructions for the Sankyo compressor are as follows:
 1. Place the compressor in the mounting brackets and install attachment bolts. Do not torque attachment bolts at this time.
 2. Install compressor drive belt. Rotate compressor drive belt. Rotate compressor in mounting bracket slots to obtain a belt tension of 85 to 90 lbs. Torque the four attachment bolts 300 to 350 in.-lbs. (Also, refer to paragraph 14-23.)
 3. Check the oil level in the compressor in accordance with instructions given in paragraph 14-21.
 4. Connect the discharge and suction lines to their respective fittings.

WARNING

If the air conditioner is to be operated on the ground for servicing, the test area should be clean and free of any loose objects lying on the ramp. Only the service valves located on the evaporator assembly should be used for testing.

14-21. CHECK COMPRESSOR OIL. The oil level should be checked any time the system is discharged.

- a. The following steps should be followed to perform York compressor oil check.
 1. It will be necessary to discharge the system. (Refer to paragraph 14-12.)
 2. Fabricate an oil dipstick. (Refer to Figure 14-9.)
 3. Remove the oil fill plug. (A.375 inch plug in the top side of the compressor crankcase.)
 4. Before inserting the dipstick, the crankshaft Woodruff key should be located in the up position. (The front face of the compressor clutch is marked with a stamped "K" indicating the key position.) The oil level should be measured from the lowest point in the crankcase. Use the long end of the dipstick. (See Figure 14-9.)
 5. With the compressor in the installed position, use Table XIV-III to determine the amount of oil in crankcase.
 6. The compressor should never be operated with less than 6 ounces of oil. When oil is added, the level should not go above 10 ounces. Piper refrigerant oil PMS-L2000 or equivalent 500 viscosity refrigerant oil must be used.
 7. Evacuate and charge system. (Per paragraphs 14-13 and 14-14.)

NOTE

The 10 ounce oil level is required in compressors installed on new systems. Some oil is distributed in the system during operation. Replacement compressors should be charged with 10 ounces of oil.

CAUTION

The oil plug should not be removed with pressure in the system.

CHEROKEE ARROW III SERVICE MANUAL

TABLE XIV-III. COMPRESSOR OIL CHARGE

Oil Charge Ounces	6	8	10
Dipstick Reading Inches	13/16"	1.00"	1-3/16"

- b. Use the following instructions for checking Sankyo compressor oil level.
1. Run the compressor for 10 minutes with engine at 1900 rpm.

WARNING

If the air conditioner is to be operated on the ground for servicing, the test area should be clean and free of any loose objects lying on the ramp. Only the service valves located on the evaporator assembly should be used for testing.

2. Discharge the system per paragraph 14-12; be careful not to loose any oil.
3. Remove the oil fill plug.
4. Position the rotor to top dead center (refer to Figure 14-8a) by rotating the clutch front plate until the casting mark is visible in the center of the hole.
5. Rotate the clutch front plate clockwise by approximately 110° (refer to Figure 14-8b).
6. Insert dipstick No. 32447 purchased from Sankyo (see paragraph 14-18 for Sankyo address).
7. Remove the dipstick and count the number of increments of oil. The acceptable oil level in increments is 7 to 10. This represents between 2.6 and 4.4 fluid ounces.
8. When oil is added, Piper refrigerant oil PMS-L2000 or equivalent 500 viscosity refrigerant oil must be used.
9. When installing the oil filler plug, make sure the sealing O-ring is not twisted and that no dirt nor particles are on the O-ring or seat. Torque the plug to 6-9 foot-pounds. Do not overtighten the plug to stop a leak; remove the plug and install a new O-ring.
10. Evacuate and charge the system (refer to paragraphs 14-13 and 14-14).

CAUTION

The oil plug should not be removed with pressure in the system.

14-22. REPLACEMENT OF YORK COMPRESSOR AND/OR ALTERNATOR DRIVE BELTS. (Refer to Figure 14-9a.) (PA-28R-201)

- a. Remove the old belts by removing the spinner, propeller, nose cowl, right front baffle, starter ring gear assembly and drive belts.
- b. Place the new belt or belts in their appropriate positions on the starter ring gear sheaves.
- c. Reinstall the starter ring gear assembly, propeller and spinner.
- d. Route the belts to the proper pulley sheaves as shown in Figure 14-9a.

CAUTION

Do not force the belts into the pulley sheaves. Remove the idles assemblies if necessary and the alternator lower mounting bolts in order to install the belts.

CHEROKEE ARROW III SERVICE MANUAL

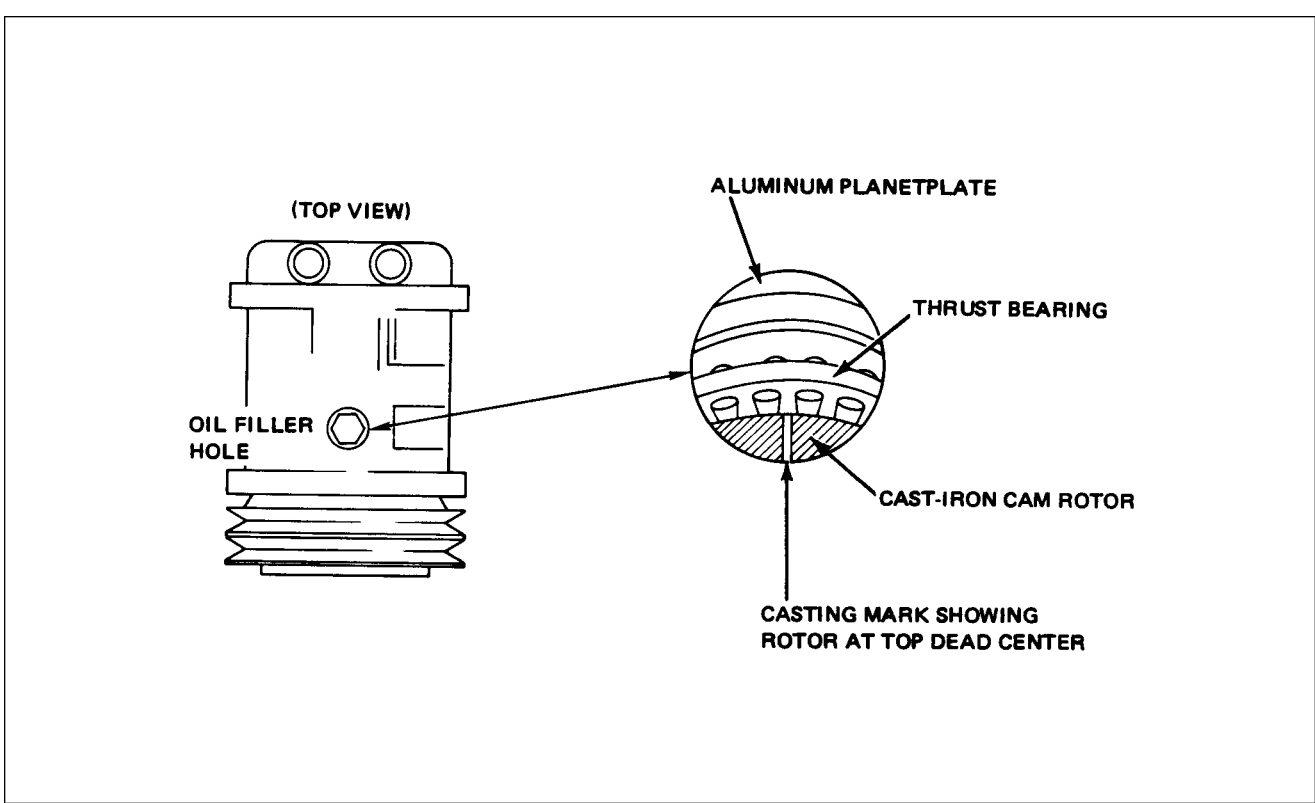

Figure 14-8a. Top Dead Center Casting Mark (Sankyo Compressor)

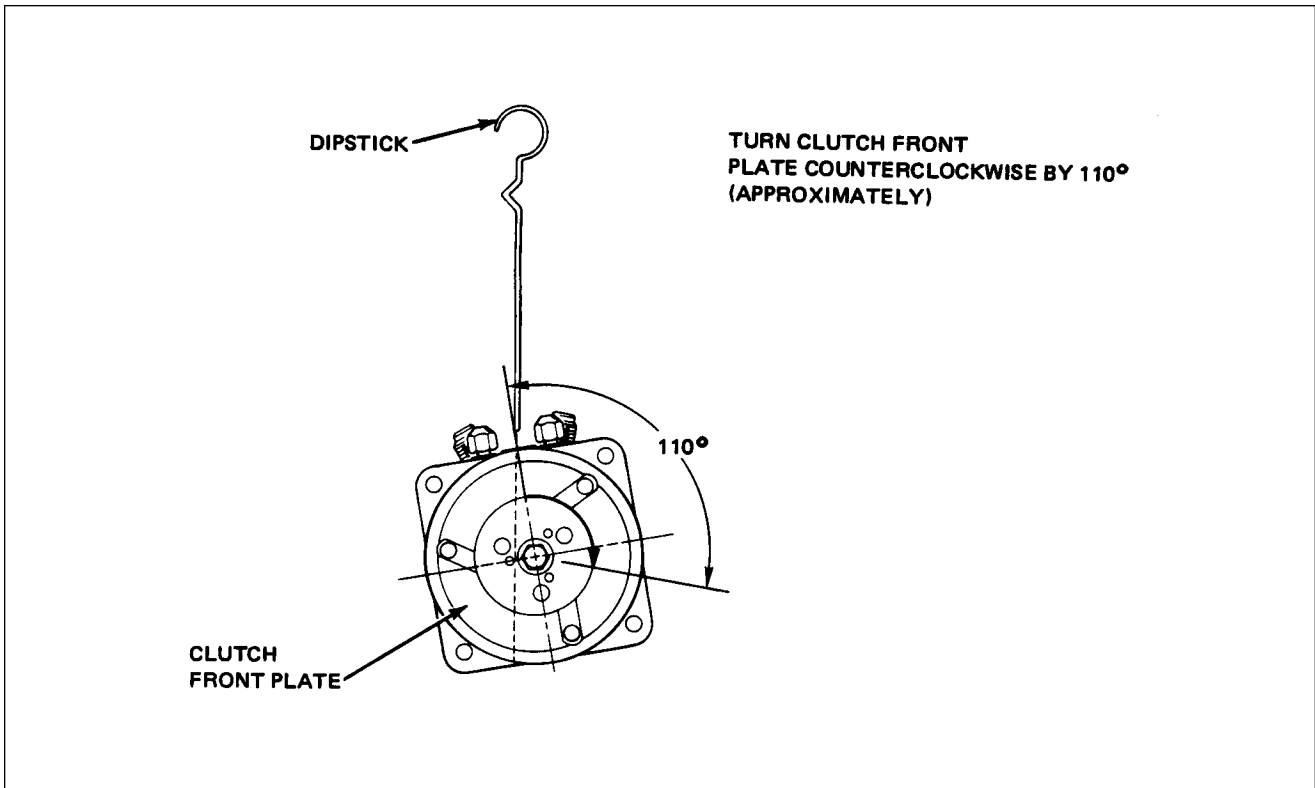

Figure 14-8b. Rotation of Clutch Front Plate (Sankyo Compressor Oil Check)

CHEROKEE ARROW III SERVICE MANUAL

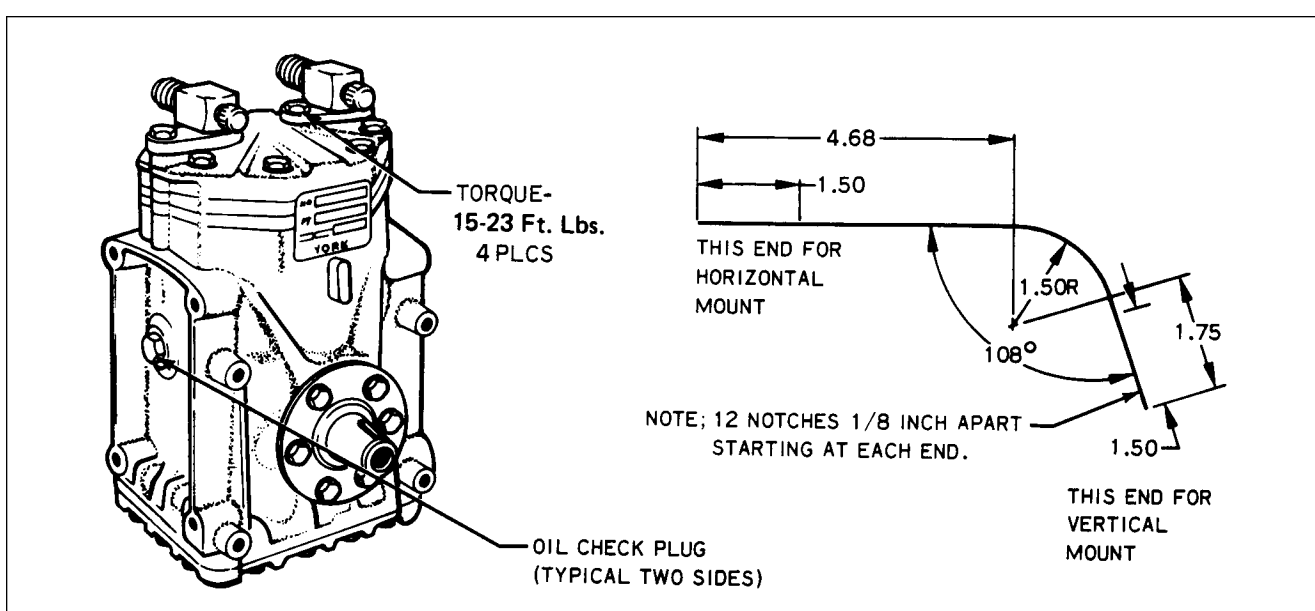

Figure 14-9. York Compressor and Fabricated Oil Dipstick (PA-28R-201)

- e. Check the belt and pulley alignment of the compressor and/or alternator by the following method:
1. A datum line must be established for checking belt and pulley alignment. A nominal dimension must be established between the forward edge of the compressor belt and the forward machined surface of the ring gear. This dimension should be taken at the ring gear assembly where the belt is in its sheave. The amount of misalignment can then be determined at the other pulley sheaves by using a stiff straightedge of sufficient length to extend from the front of the ring gear to the component sheaves.

NOTE

Ensure adequate ring gear surface contact to provide a solid base for the straightedge.

2. Obtain a basic measurement from the top of the ring gear by measuring the width of the starter ring gear plus the dimension from the forward machined surface of the ring gear to the forward edge of the compressor drive belt. (Refer to Figure 14-9a.)
 3. The check and adjustments of the compressor and/or alternator drive belts require different procedures; refer to following appropriate instructions:
- f. Compressor Belt Alignment: (Refer to Figure 14-9a.)
1. Place the straightedge against the right forward side of the ring gear and measure belt alignment at compressor sheave (Point - B).
 2. Measure belt alignment at the compressor idler pulley (Point - A). The belt misalignment at Point - A should be half the misalignment of Point - B and the dimension at the top of the ring gear and in the same direction fore and aft.
 3. If at Point - A nominal misalignment is not within $\pm .030$ of an inch as obtained in step 2, add or remove shims as required. Belt alignment should be made as close to nominal as shims will allow.

CHEROKEE ARROW III SERVICE MANUAL

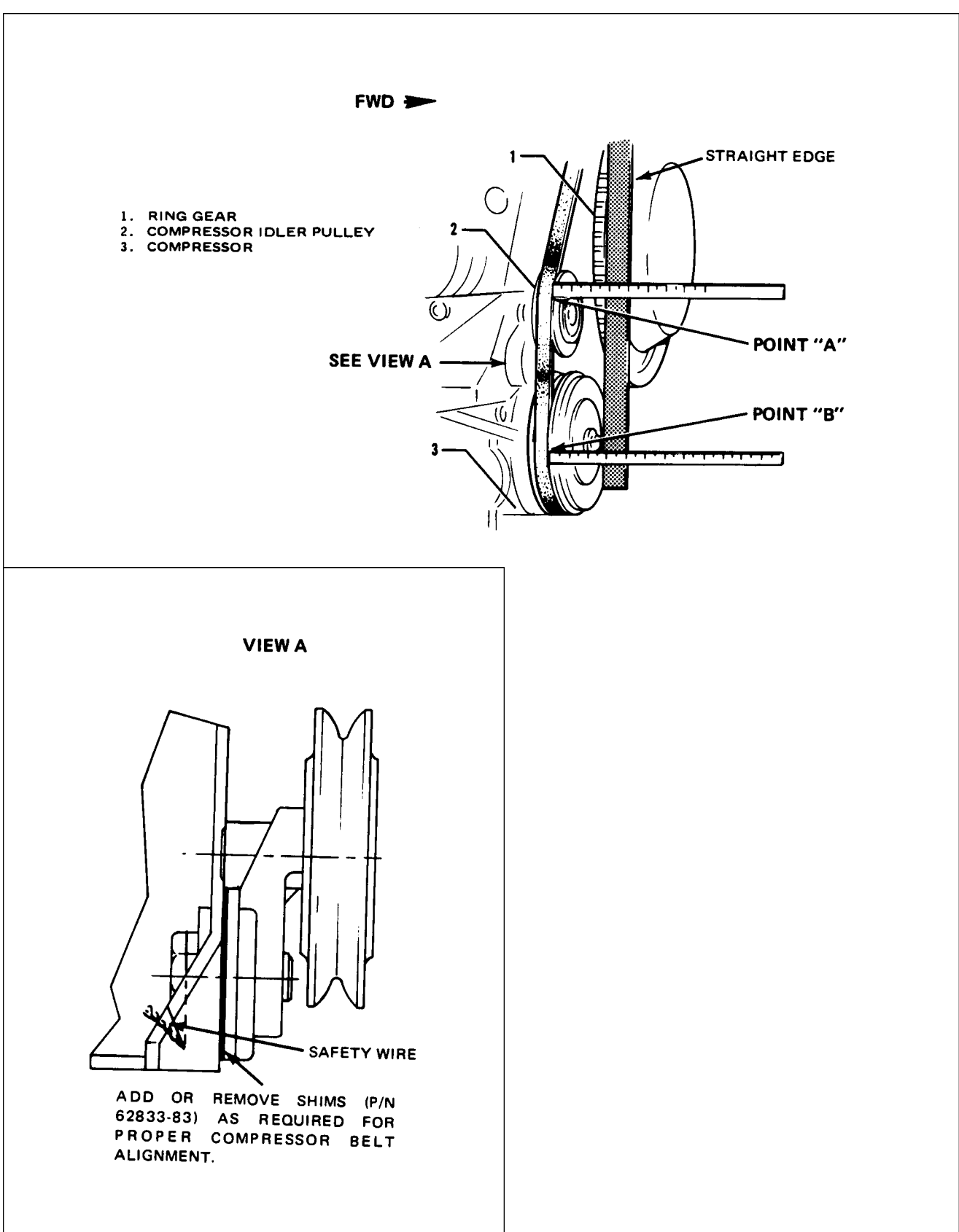

Figure 14-9a. Compressor and Alternator Belt Installation (Lycoming)

CHEROKEE ARROW III SERVICE MANUAL

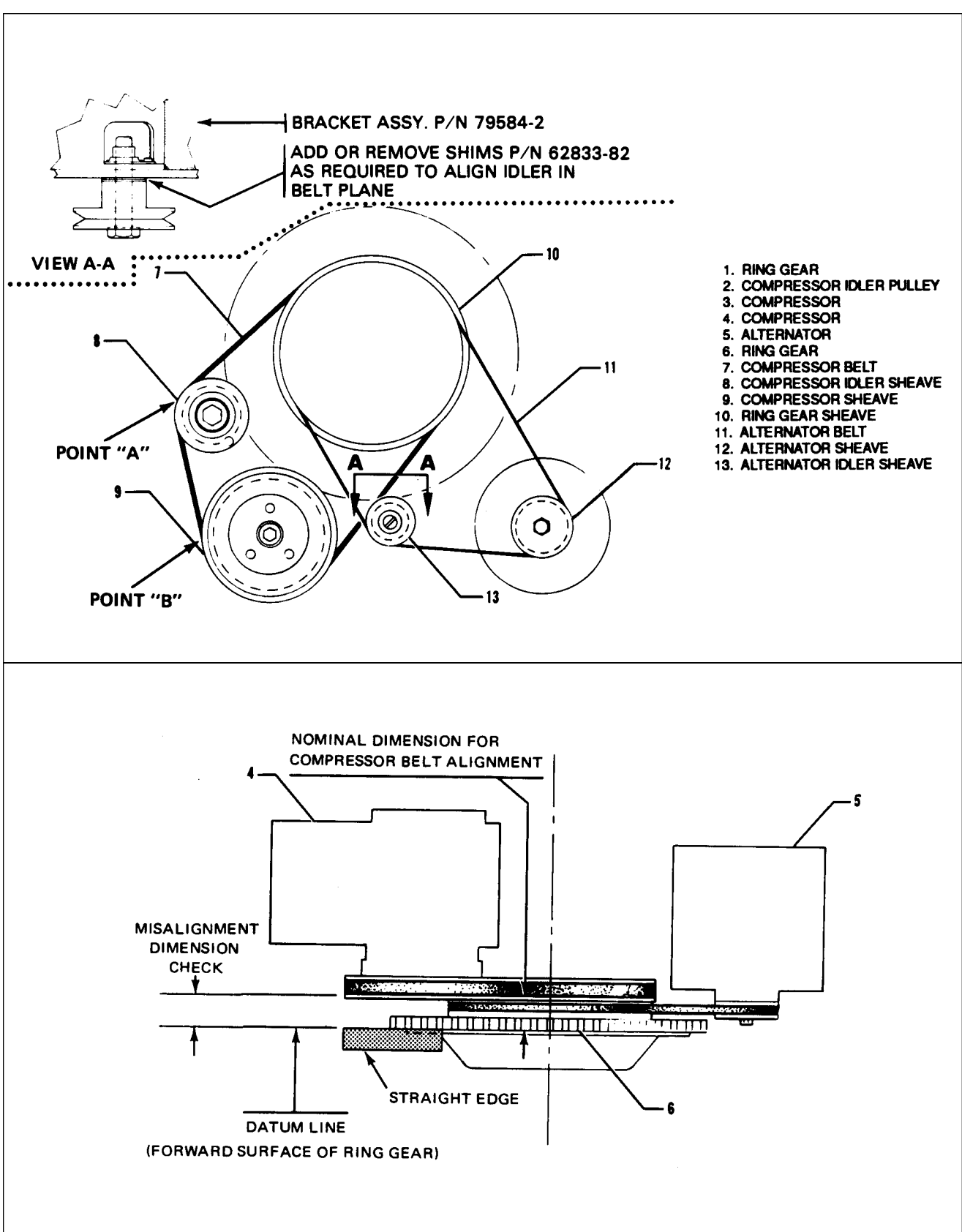

Figure 14-9a. Compressor and Alternator Belt Installation (Lycoming) (cont.)

CHEROKEE ARROW III SERVICE MANUAL

g. Alternator Belt Alignment: (Refer to Figure 14-9a.)

1. With the alternator belt installed, align the idler pulley in the belt plane by adding or removing shims, P/N 62833-82 as required. Refer to paragraph 14-23 for belt tension adjustment.

14-23. ADJUSTMENT OF DRIVE BELT TENSION.

a. The adjustment of the York compressor and/or alternator drive belts installed on the PA-28R-201 is very important to obtain long belt life and proper component operation. (Refer to Parts Catalog for belt numbers.) Adjust the belt tensions on PA-28R-201 as follows:

1. Tighten the new compressor belt to 120 lbs span tension and the new alternator belt to 90-100 lbs. span tension. When using the plastic type alternator belt, adjust the tension at 65-70 lbs for new belt.

NOTE

The higher tension specified for a new belt is to compensate for the initial stretch that takes place as soon as it is operated. These higher tension values should not be applied to belts which previously have been used. See tensions noted below for used belts.

2. Install the right front engine baffle and secure the side engine cowl latches, if previously removed.
3. Run the engine for a 15 minute period at 1200 rpm.

WARNING

If the air conditioner is to be operated during ground servicing, the test area should be clean and free of any loose objects lying on the ramp. Only the service valve located on the evaporator assembly should be used for testing.

4. Shut down engine and recheck the belt tensions. If the compressor belt tension falls as low as 60 lbs., reset to 80 lbs. If the alternator belt tension falls as low as 50 lbs., retention to 70 lbs. The plastic type belt should be between 35-40 lbs.
 5. This tension check should be made at every 100 hours or annual inspection, whichever occurs first.
 6. Check all idler and bracket bolts for safety and replace engine cowling.
- b. Adjust the Sankyo compressor on the PA-28R-201T as follows:
1. Rotate the compressor to obtain tension of 45 to 50 lbs. for new or old belts.
 2. Run the engine for a 15 minute period at 1900 rpm with the compressor engaged.

WARNING

If the air conditioner is to be operated during ground servicing, the test area should be clean and free of any loose objects lying on the ramp. Only the service valve located on the evaporator assembly should be used for testing.

3. Shut down engine and recheck the belt tensions. New belt tension should fall back to desired tension of 45 to 50 lbs. Old belts reinstalled should retain the 45 to 50 lbs. span tension.
4. This tension check should be made at every 100 hours or annual inspection, whichever occurs first.

CHEROKEE ARROW III SERVICE MANUAL

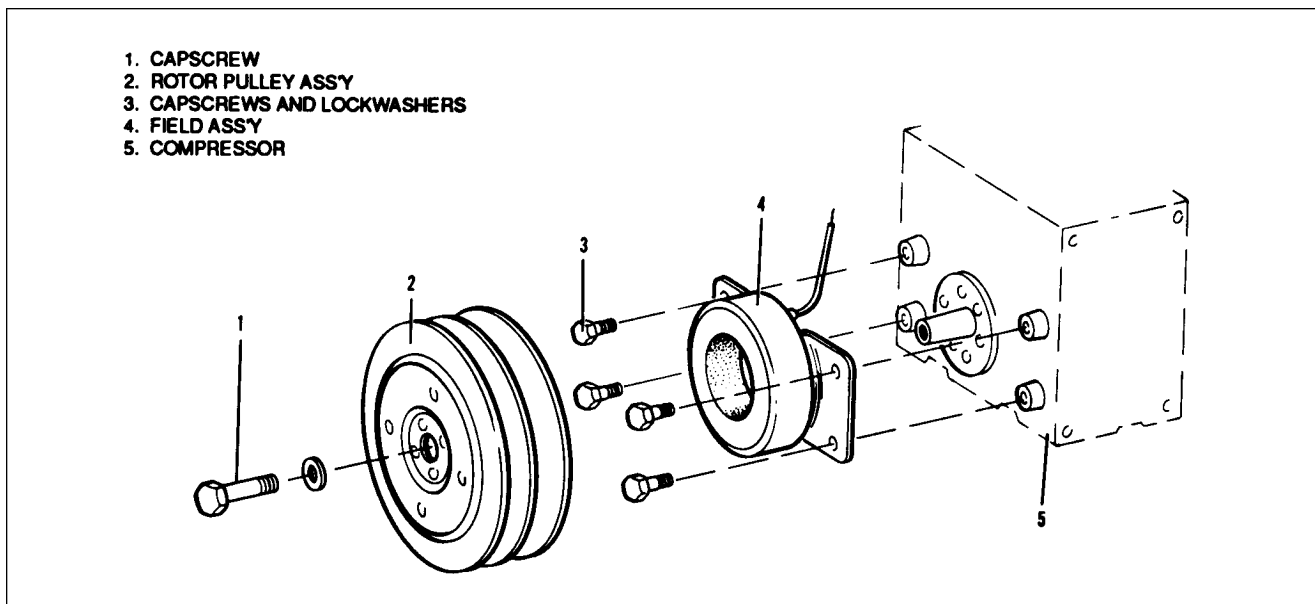

Figure 14-10. Magnetic Clutch (York Compressor)

14-24. MAGNETIC CLUTCH. (York Compressor)

14-25. MAGNETIC CLUTCH REMOVAL. (Refer to Figure 14-10.)

- Remove the self-locking capscrew and washer (1) from the compressor shaft.
- Insert a 5/8 -11 UNC-2B bolt in the threaded portion of the hub and tighten. The pressure exerted by the bolt on the end of the compressor crankshaft will force off the rotor pulley assembly (2) without damage to the clutch or compressor.

CAUTION

Do not use a wheel puller on the outer flange of the pulley. This can damage the pulley grooves or clutch bearings.

- Remove the four bolts securing the field assembly against the compressor bosses and remove the bolts, washers and field assembly.

14-26. MAGNETIC CLUTCH INSTALLATION. (Refer to Figure 14-10.)

- Position the field assembly (4) against the compressor bosses, with the electrical leads to the cylinder side of the compressor.
- Secure the field assembly (4) with four capscrews and lockwashers (3), do not torque at this time.
- Connect the electrical lead from the field assembly.

NOTE

The compressor shaft must be clean and free from burrs.

CHEROKEE ARROW III SERVICE MANUAL

- d. Slide the pulley assembly (2) over the field assembly and onto the crankshaft, now torque the field assembly 85 to 120 inch pounds. Then secure pulley assembly with washer and new self-locking capscrew (1). Torque the capscrew to 180 to 240 inch-pounds.

NOTE

If the clutch is not engaged while tightening the capscrew, insert a spanner into the holes provided in the armature face.

- e. Spin the pulley by hand to check for any interference between the field (4) and rotor pulley assemblies (2). A rubbing noise can be heard as the pulley rotates if there is interference. The rotor pulley assembly must be removed and the mounting of the field assembly adjusted until the interference is eliminated.

14-27. REFRIGERANT LINES AND ROUTING. The refrigerant lines in this aircraft are flexible high pressure hoses and should be handled accordingly. The hoses in the power plant area are routed so as to provide maximum protection from heat and abrasion. They couple at the firewall to hose routed through the two inboard, external hat section on the bottom of the fuselage, up thru the floor to the condenser and evaporator in the tail cone. The discharge is in the right hat section and the suction in the left.

NOTE

Before any of the hose couplings are uncoupled, the system must be completely discharged. (See paragraph 14-12.)

14-28. RECEIVER-DEHYDRATOR.

14-29. RECEIVER-DEHYDRATOR REMOVAL. This unit is mounted on the inboard side of the evaporator assembly housing.

- a. Discharge the system of all refrigerant. (See paragraph 14-12.)
- b. Uncouple the refrigerant lines at the receiver-dehydrator. (See paragraph 14-5, B-7.)
- c. Remove the clamp attaching the unit to the evaporator housing.

NOTE

This part is not serviceable, it must be replaced. The receiver dehydrator should be replaced when the system has been operated without a charge or is left open.

14-30. RECEIVER-DEHYDRATOR INSTALLATION.

- a. Slip the mounting bracket around the receiver and put it in place on the evaporator housing with the tube fitting on top. Align the fittings to the proper line before securing the mounting bracket.

NOTE

Torque the fittings (see Table XIV-I).

- b. Evacuate and recharge the system in accordance with paragraphs 14-13 and 14-14.

CHEROKEE ARROW III SERVICE MANUAL

14-31. CONDENSER. The condenser is mounted in a frame assembly located in the bottom of the fuselage between stations 156.00 and 191.00.

14-32. CONDENSER ASSEMBLY REMOVAL.

- a. Discharge the system. (See paragraphs 14-5 and 14-12.)
- b. Remove access panel from the aft bulkhead of cabin.
- c. Remove the forward cover panel.
- d. Uncouple the suction and discharge hoses at the condenser fitting. (See paragraph 14-5, B-7). Remove the hose clamps holding the hoses to the condenser frame.
- e. Remove the AN-3 bolts from the upper ends of the side hinges and rod ends.
- f. Support the condenser assembly and remove the bolt attaching the actuating rod to the condenser assembly.
- g. Lower the aft end of the assembly on the piano hinge at the forward end of assembly.
- h. Remove the eight screws attaching the piano hinge to the condenser frame assembly and remove from aircraft.
- i. To remove condenser core from assembly, remove the screws in the side mounting frame.

14-33. CONDENSER INSTALLATION.

- a. Install the condenser core to the frame assembly with the hose fitting forward and up.
- b. Place the condenser and frame assembly to the fuselage frame mounting bracket and insert the (8) screws into the piano hinge.
- c. Attach the side hinges and actuating rod and rig per paragraph 14-35.
- d. Seal and couple the hose fittings (seal with Loctite refrigerant sealant applied to flanges only).
- e. Adjust the condenser in accordance with paragraph 14-35.
- f. Seal all around cover panel (and aft cover panel if removed) with Permagum Bead No. 576 purchased from Prestolite Engineering Company. (See Figure 14-11.)

WARNING

Whenever it is necessary to remove and replace the cabin rear panel, it should be replaced and sealed in the original manner to prevent exhaust gases from entering the cabin. After removing and replacing the rear panel, conduct a carbon monoxide test on ground and in flight with or without the air conditioner operating. Presence of CO₂ shall not exceed 1 part in 20,000.

14-34. CONDENSER DOOR ACTUATOR. The actuator is on a bracket mounted between two bulkheads in the tail cone. It is coupled to the condenser assembly through a bellcrank mounted to a bracket on the bulkhead aft of the condenser. The actuator travel is controlled by two limit switches. Both the up and down switches are located on the actuator. Refer to Figure 14-11 for the switch locations.

14-35. CONDENSER ASSEMBLY RIGGING INSTRUCTIONS. (Refer to Figure 14-11.) The condenser assembly is actuated by an electric motor through bellcranks, push rods and limit switches.

It is necessary for the condenser door to fit flush with the fuselage skin and with increased force along the forward edge. The following steps will help accomplish this requirement: (Refer to Figure 14-11.)

- a. Adjust open limit switch (5) to open the condenser door (8) five inches when measured from the leading edge of the door to the fuselage skin.

CHEROKEE ARROW III SERVICE MANUAL

SEAL ALL AROUND FORWARD AND AFT COVERS WITH PERMAGUM BEAD NO. 576
PURCHASED FROM PRESTOLITE ENGINEERING COMPANY.

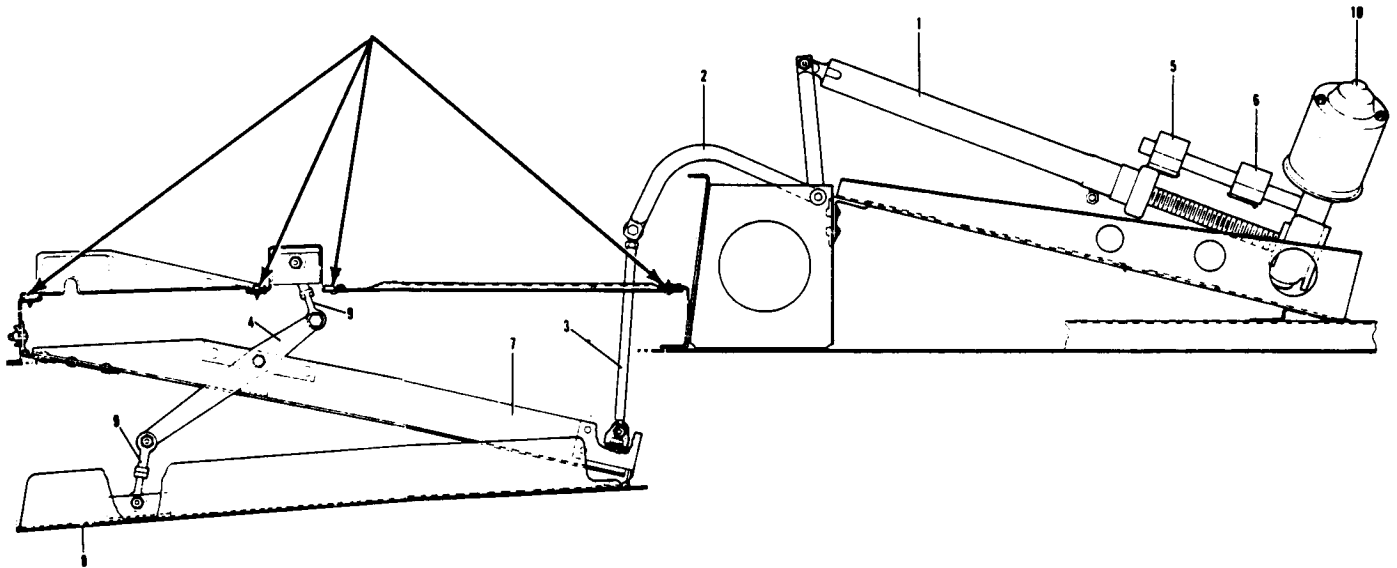

1. ACTUATING TRANSMISSION ASSY.
2. BELLCRANK ASSY. (CONDENSER)
3. PUSH ROD ASSY.
4. BELLCRANK ASSY. (MECHANISM)
5. OPEN LIMIT SWITCH
6. CLOSED LIMIT SWITCH
7. CONDENSER
8. CONDENSER DOOR
9. PUSH ROD
10. TRANSMISSION MOTOR ASSY.

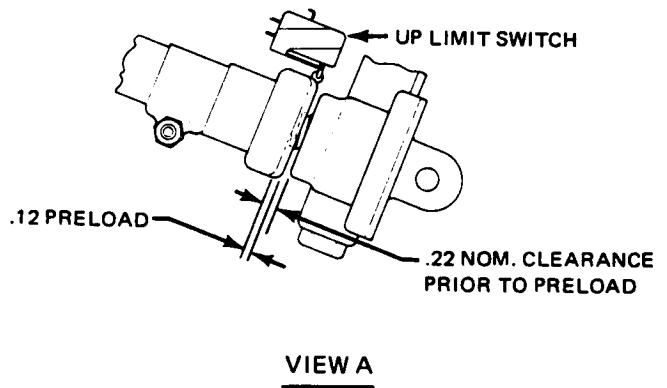

Figure 14-11. Condenser Air Scoop Installation

CHEROKEE ARROW III SERVICE MANUAL

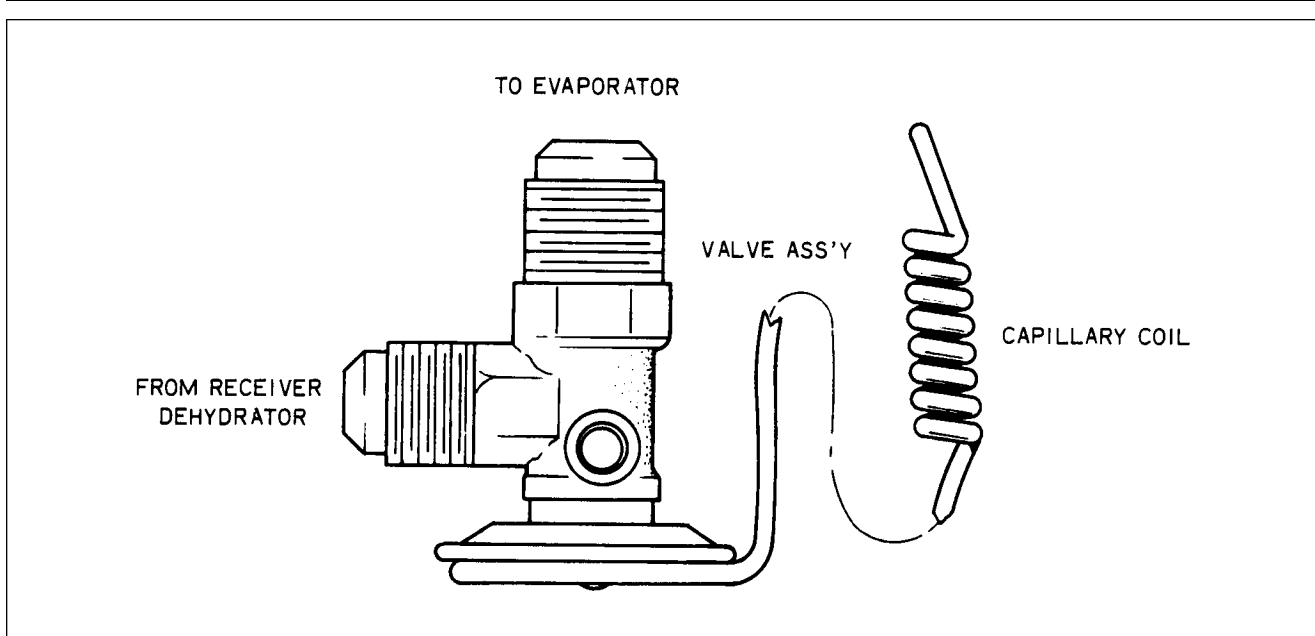

Figure 14-12. Expansion Valve

- b. Adjust the push rods (9) so that a vertically measured gap of .16 of an inch exists along the trailing edge of the door at the instant the forward edge of the door becomes flush with the fuselage skin.
- c. With the door fully closed, adjust the CLOSED (6) limit switch so that the actuator (1) travels an additional .12 of an inch after the door is fully closed, this is necessary to preload the mechanism. Refer to Figure 14-11.
- d. Cycle the assembly several times to be certain it operates properly without binding.

14-36. EXPANSION VALVE. (See Figure 14-12.)

14-37. EXPANSION VALVE REMOVAL. The expansion valve is located in the evaporator assembly between the receiver drier and the evaporator inlet. The capillary coil is attached to the evaporator outlet line.

- a. Remove the necessary access panels and discharge system.
- b. Remove the capillary coil from the outlet line. (Do not link the capillary tube.)
- c. Uncouple all related tube fittings. (See paragraph 14-5, B-7.)

NOTE

If this part is not serviceable, it must be replaced with a new part.

14-38. EXPANSION VALVE INSTALLATION.

- a. Install the expansion valve in the inlet line of the evaporator core by coupling the related fittings. (Seal all couplings with sealant applied to tube flanges only.) Torque fittings per Table XIV-I.
- b. Secure the capillary coil to the evaporator outlet line.
- c. Evacuate and charge the system. (See paragraphs 14-13 and 14-14.) Check for leaks. (See paragraph 14-9.)
- d. Replace access panels.

CHEROKEE ARROW III SERVICE MANUAL

14-39. EVAPORATOR ASSEMBLY. The evaporator assembly consists of the evaporator core, receiver dehydrator, expansion valve, circulating fan and pressure switch together with necessary housing and plumbing. The housing is fabricated of Cylolac type material. The condensed moisture is dumped over board through a hose clamped to a fitting on the bottom of the evaporator housing.

14-40. EVAPORATOR ASSEMBLY REMOVAL. The evaporator assembly is located behind the cabin rear panel, attached to the mounting panel with 12 screws and washers, and a bracket securing the back to the mounting panel.

- a. Remove air conditioning filter cover, filter and rear access panels.

NOTE

Discharge the system before disassembling. (Refer to paragraph 14-12.)

- b. Uncouple the liquid line from the inlet side of the receiver-dehydrator and the suction line from the evaporator core outlet. (See paragraph 14-5, B-7.)
- c. Disconnect the related electrical wires.
- d. Remove flexible air duct from housing outlet. Remove drain hose from housing.
- e. Remove temperature probe from evaporator housing.
- f. Remove the screws attaching the support bracket and evaporator housing to the mounting panel. Remove the assembly through the access hole in the bulkhead.

14-41. EVAPORATOR ASSEMBLY INSTALLATION.

- a. Cement gasket in place on the flanges of the evaporator housing and attach the large end of the mounting gasket to the back of the housing.
- b. Install the housing through the access hole with the air duct outlet on top. Mate the mounting flanges to the mating surface of the mounting panel and insert the screws. (Do not tighten at this time.)
- c. Line up the mounting bracket with mating holes in mounting panel, insert screws and tighten. Tighten screws in the flange at this time. Be certain gasket is in place. The flange must have an air tight seal.
- d. Couple the suction and discharge lines to their respective fittings (apply Loctite refrigerant sealant to tube flanges only).
- e. Evacuate and charge system. (See paragraphs 14-13.)
- f. Check for leaks (see paragraph 14-9) if no leaks are detected. Seal and install access panel on evaporator housing.
- g. Couple flexible air duct and drain tube.
- h. Make and check electrical connections.
- i. Check operation of blower and refrigerant systems.
- j. Install rear bulkhead panels. Be certain to seal. (See NOTE.)

WARNING

Whenever it is necessary to remove and replace the cabin rear panel, it should be replaced and sealed in the original manner to prevent exhaust gases from entering the cabin. After removing and replacing the rear panel, conduct a carbon monoxide test on the ground and in flight with and without the air conditioner operating. Presence of CO shall not exceed 1 part in 20,000.

CHEROKEE ARROW III SERVICE MANUAL

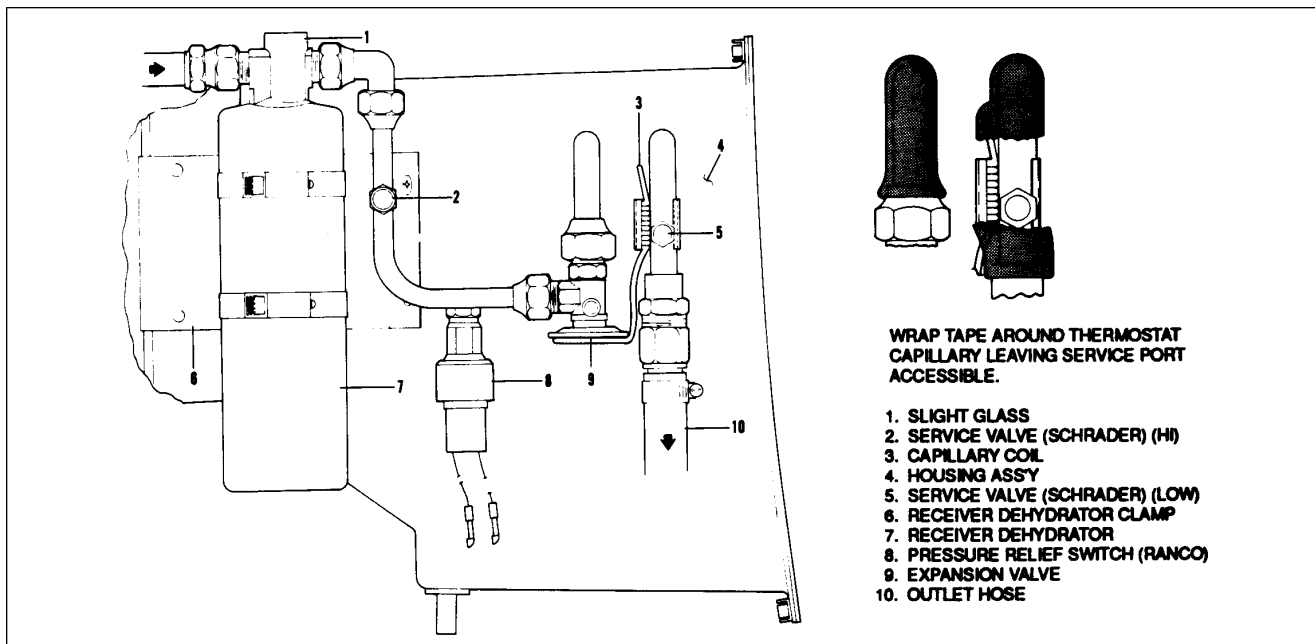

Figure 14-13. Components Installation

14-42. PRESSURE RELIEF SWITCH (Ranco). The pressure relief switch automatically prevents the system from over pressurization by breaking the electrical circuit to the magnetic clutch, stopping the compressor until pressure is reduced. The switch is located in the line between the receiver and expansion valve, and set to cut out at 350 ± 10 psi and cut in at 250 ± 10 psi.

NOTE

Before the relief switch is removed, the air conditioning system must be discharged. (See paragraph 14-12.)

14-43. ELECTRICAL INSTALLATION. The electrical system, routing and component are installed and routed in the conventional aircraft manner. The wiring harness is connected to switches in the climate control center on the right side of the instrument panel. The harnesses cross the instrument panel to the left side where two (2) wires are taken off for the compressor clutch. The harness then passes aft along the left side of the fuselage where it connects to the blower motor, pressure relief switch and the condenser actuating motor.

NOTE

Newer models of the PA-28R-201T air conditioning throttle switch may appear different in design, but is adjusted and inspected the same way that is outlined in paragraph 14-44 of this section.

14-44. AIR CONDITIONING THROTTLE SWITCH. This switch is responsible for shutting down the air conditioning system when the airplane is at full throttle enabling maximum performance. On the PA-28R-201 model, the switch is behind the control quadrant and is actuated by the throttle lever. With throttle against full open stop, adjust switch so the $.040 \pm .010$ clearance is obtained (refer to Figure 14-14). On the PA-28R-201T, the switch is in back of the instrument panel in the manifold pressure gauge line. No adjustment is necessary.

14-45. FUSE REPLACEMENT. There are three fuses located behind the air conditioning system control panel. A 20 amp circuit breaker mounted in the circuit breaker panel protects the complete air conditioning electrical system.

CHEROKEE ARROW III SERVICE MANUAL

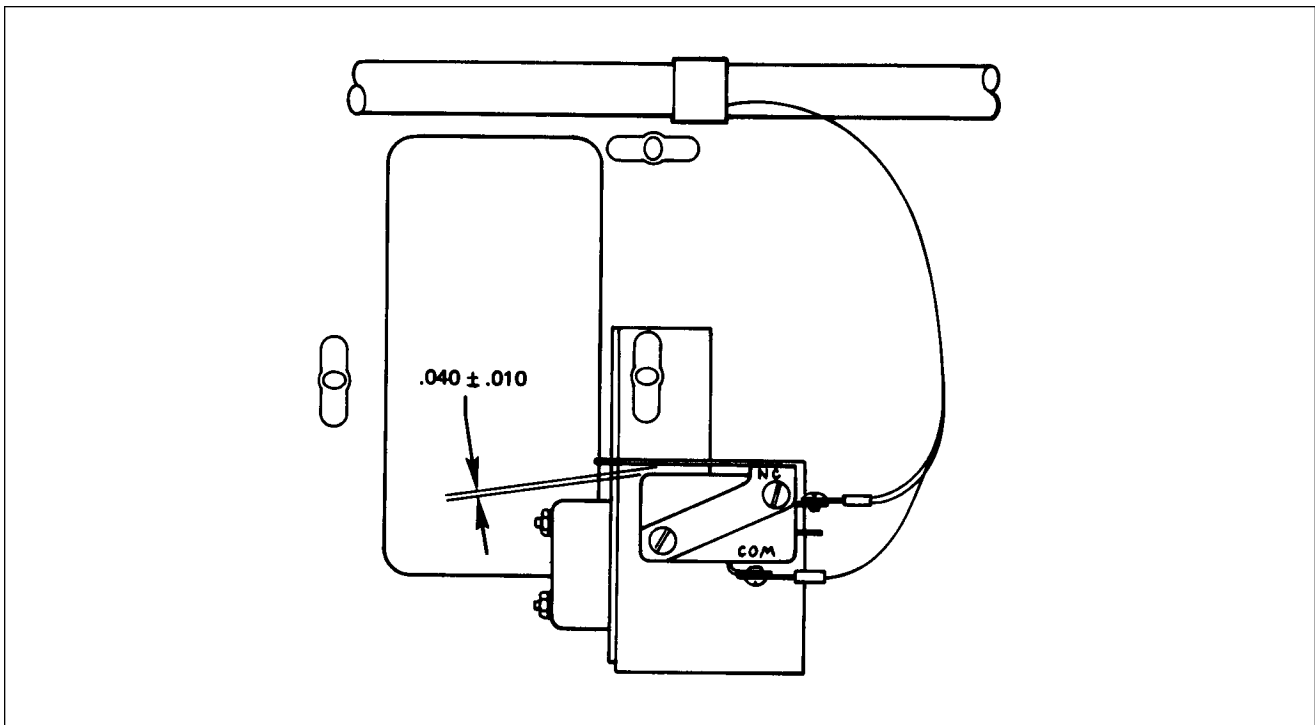

Figure 14-14. Adjustment of Air Conditioning Throttle Switch (PA-28R-201)

14-46. SHOULDER-HARNESS INERTIAL REEL ADJUSTMENT.

- a. Allow the harness to wind up on the reel as much as possible.
- b. On the end of the reel, pry off the plastic cap over the spring, making sure the spring does not come out of the plastic cap, and set cap aside.
- c. Unwind the harness completely then measure and mark the harness 24 inches from the reel center.
- d. Wind the harness onto the reel until the 24 inch mark is reached then hold reel and place cap with spring over the reel shaft end.
- e. Aligning slot in shaft with spring tang, wind spring 6 turns $\pm 1/2$ turn and snap the plastic cover into holes in reel end shaft.
- f. Release harness and allowing it to wind up, extend the harness a few times to check reel for smooth operation.
- g. With reel fully wound, hold with inertia mechanism end up and pry off plastic cap over mechanism and set reel aside.
- h. Install nut in plastic cap so that stud in cap is flush with nut surface, then reposition cap over reel end and orienting properly, snap in place. Extend harness a few times to make sure action is correct.

14-47. OVERHEAD VENT BLOWER.

14-48. DESCRIPTION. The blower is mounted in the aft section of the fuselage and is connected to the overhead vent system. The blower draws air in from the dorsal fin and forces it through the ducting, whenever desired. The four position blower switch on the instrument panel controls the three speed blower.

CHEROKEE ARROW III SERVICE MANUAL

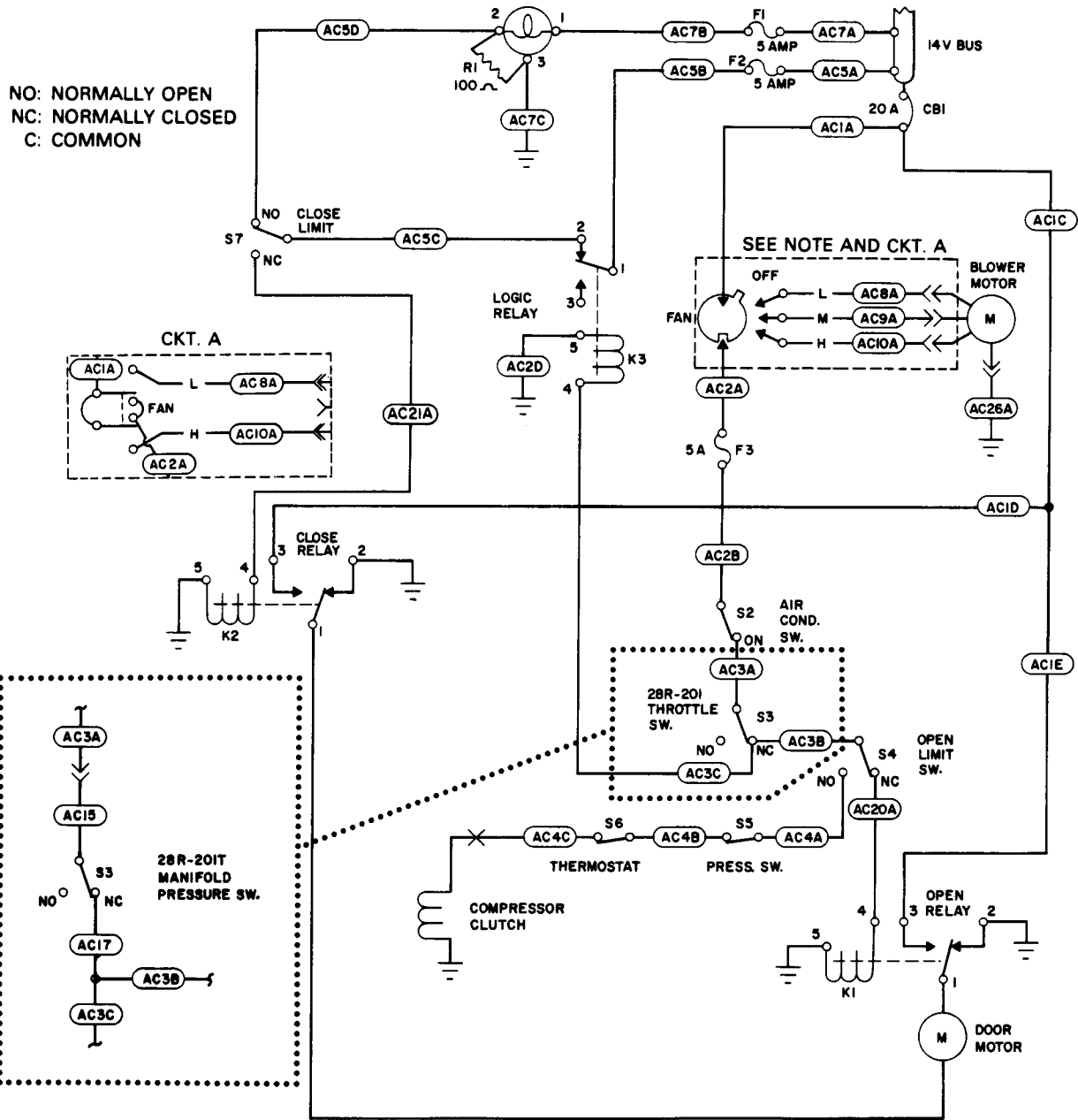

NOTE

PIPER KIT NO. 763 815V IS USED WHEN REPLACING THE FAN SWITCH ON SERIAL NUMBERS (28R-201) 28R-7737002 TO 7837019 INCLUSIVE, AND (28R-201T) 28R-7703001 TO 7803050 INCLUSIVE. THE KIT IS INSTALLED AS STANDARD EQUIPMENT AS SHOWN IN FIGURE 11-57.

Figure 14-15. Air Conditioning Wiring Schematic

CHEROKEE ARROW III SERVICE MANUAL

14-49. REMOVAL OF BLOWER ASSEMBLY.

- a. Remove the access door from the aft wall of the baggage area.
- b. With the master switch off, disconnect the plug assemblies at the blower assembly.
- c. Remove the inlet and outlet hoses from the blower assembly by removing the clamps.
- d. Remove the screws, washers and nuts that secure the blower assembly to the hangar braces.
- e. Remove the screws and washers which secure the blower assembly to the retainer and hangars.
- f. Remove the blower assembly from the aircraft.

14-50. DISASSEMBLY OF BLOWER ASSEMBLY.

- a. Remove the hose duct from the forward edge of the blower assembly by removing the nuts, washers and screws.
- b. Remove the cover from the blower assembly by removing the nuts, washers and screws.
- c. Remove the blower fan from the motor shaft by removing the set screw.
- d. For removal of the motor, proceed as follows:
 1. Separate the plate from the motor cover by carefully drilling out the connecting rivets.
 2. Cut the motor wires at the edge of the receptacle and plug and remove the wire ends from the blocks.
 3. Remove the motor from the mounting plate by removing the nuts, washers and bolts.

14-51. REASSEMBLY OF BLOWER ASSEMBLY.

- a. Mount the motor on the plate and secure it with the bolts, washers and nuts. Be sure that the motor nuts are snug and the shaft spins freely.
- b. Position the cover over the motor plate with the motor wires protruding through the cover grommet.
- c. With the holes in the cover matching the holes in the motor plate, secure the two parts together with rivets.
- d. Apply PRC-5000 sealant to fill any opening left after the wires are brought through the grommet.
- e. Install the wires in the plug and receptacle according to Table XIV-V.
- f. Position the blower fin on the motor shaft and secure with set screw.
- g. Secure the cover to the blower assembly with screws, washers and nuts.
- h. Position the hose duct on the blower assembly and secure it with screws, washers and nuts. The screws must be installed with their heads inside the duct.
- i. After cleaning the surfaces of all old sealant, use white rubber chalk PRC-5000 sealant to seal where the duct attaches to the blower assembly.

14-52. INSTALLATION OF BLOWER ASSEMBLY.

- a. Position the blower assembly in the hangars and retainer and install the washers and screws.
- b. Install the nuts, washers and screws securing the blower assembly to the hangar braces.
- c. Seal all hose joints with Arno No. C-520 gray tape; then install the inlet and outlet hoses securing them with the clamps.
- d. With the master switch off, connect the plug and receptacles at the blower.
- e. Check the blower for the proper operation.
- f. Install the access door to the aft wall of the baggage area and secure with the attaching hardware.

CHEROKEE ARROW III SERVICE MANUAL

TABLE XIV-IV. TROUBLESHOOTING CHART (AIR CONDITIONER)

Gauge Indication	Probable Causes	Remedy
High discharge pressure.	<p>Overcharge of refrigerant.</p> <p>Air in system.</p> <p>Overheated condenser due to blocking air passage.</p> <p>Flooded evaporator indicated by heavy frosting on suction line and compressor suction service valve.</p> <p>Restriction in liquid line from condenser.</p>	<p>Purge excess refrigerant.</p> <p>Check for leaks. Bleed charge from system. Evacuate and recharge system 14-13 and 14-14.</p> <p>Clean bugs and dirt from condenser fins. Straighten fins if bent.</p> <p>Check that capillary bulb is securely clamped to suction line. If capillary bulb OK, replace expansion valve.</p> <p>Check for kinked hoses and stopped up filter.</p>
Low discharge pressure.	<p>Undercharge of refrigerant. Sight glass shows bubbles or foam.</p> <p>Damaged compressor valves or dirt under valves.</p> <p>Damaged compressor. Worn or broken piston or piston rings.</p>	<p>Add refrigerant until bubbles disappear. Check system leaks 14-17, 14-10 and 14-11.</p> <p>Replace compressor, 14-18.</p> <p>Replace compressor, 14-18.</p>

CHEROKEE ARROW III SERVICE MANUAL

TABLE XIV-IV. TROUBLESHOOTING CHART (AIR CONDITIONER) (cont)

Gauge Indication	Probable Causes	Remedy
<p>Low suction pressure. (Accompanied by icing evaporator.)</p> <p>Low suction pressure. (Evaporator not cold enough) suction gauge may read a vacuum indicating evaporator lacks refrigerant.</p>	<p>Low air supply through evaporator.</p> <p>Very dirty evaporator fins and coils.</p> <p>Undercharge of refrigerant. Moisture freezing in expansion valve. Valve will show frost. Expansion valve inlet screen clogged. Inoperative expansion valve. Valve stuck closed or capillary bulb has lost its charge.</p> <p>Restriction anywhere in liquid line. Restriction will show first.</p>	<p>Repair blower or blower motor. Clean stoppage in air ducts.</p> <p>Clean and flush with water.</p> <p>Add refrigerant. Install new dryer. Evacuate and recharge 14-13 and 14-14.</p> <p>Remove screen. Clean with solvent and replace. Warm capillary by holding in hand. If suction pressure does not charge, replace expansion valve.</p> <p>Locate restriction and repair.</p>
<p>High suction pressure.</p>	<p>Capillary bulb clamp loose on suction line. Suction line shows frost.</p> <p>Expansion valve not closing. Evaporator flooded. Suction line frosted to compressor.</p> <p>Compressor drive belt slipping.</p>	<p>Clean contact surfaces of suction line and cap bulb. Tighten clamp.</p> <p>Replace expansion valve.</p> <p>Adjust belt tension, 14-23.</p>

CHEROKEE ARROW III SERVICE MANUAL

TABLE XIV-IV. TROUBLESHOOTING CHART (AIR CONDITIONER) (cont)

Gauge Indication	Probable Causes	Remedy
High suction pressure. (cont)	Magnetic clutch slipping. Leaking or broken compressor valves.	Check electrical circuit for correct voltage to clutch coil. Clean clutch surfaces of oil. Replace compressor.
Trouble	Cause	Remedy
Door will not close when air conditioner switch is in OFF position. System produces no cooling.	Faulty relay "K-2." <u>Electrical</u> Blown fuse in control head. Open circuit breaker. Broken or disconnected electrical wire. Broken or disconnected ground wire. Clutch coil burned out or disconnected.	Replace relay. Replace fuse. Reset circuit breaker. Check all terminals for loose connections; check wiring for hidden breaks. Check ground wire to see if loose, broken, or disconnected. Check current flow to clutch, replace if inoperative.

CHEROKEE ARROW III SERVICE MANUAL

TABLE XIV-IV. TROUBLESHOOTING CHART (AIR CONDITIONER) (cont)

Trouble	Cause	Remedy
<p>System produces no cooling. (cont)</p>	<p><u>Electrical</u> (cont)</p> <p>Thermostat sensing element defective.</p> <p>Blower motor disconnected or burned out.</p> <p><u>Mechanical</u></p> <p>Loose or broken drive belt.</p> <p>Compressor partially or completely frozen.</p> <p>Expansion valve stuck in open position.</p> <p><u>Refrigeration</u></p> <p>Broken refrigerant line.</p> <p>Leak in system.</p>	<p>Check thermostat and cabin comfort control panel.</p> <p>Check current flow to blower motor. Repair or replace if inoperative.</p> <p>Replace drive belts and/or tighten to specifications, 14-22 and 14-23.</p> <p>Remove compressor for service or replacement, 14-18.</p> <p>Replace expansion valve, 14-35.</p> <p>Examine all lines for evidence of breakage by external stress or rubbing wear.</p> <p>Evacuate system, apply static charge, leak test system, and repair leak as necessary, 14-13 and 14-9.</p>

CHEROKEE ARROW III SERVICE MANUAL

TABLE XIV-IV. TROUBLESHOOTING CHART (AIR CONDITIONER) (cont)

Trouble	Cause	Remedy
System produces no cooling. (cont)	<p>Compressor shaft seal leaking.</p> <p>Clogged screen or screens in receiver dehydrator or expansion valve; plugged hose or coil.</p>	<p>Replace compressor, 14-18.</p> <p>Repair as necessary.</p>
System will not produce sufficient cooling.	<p><u>Electrical</u></p> <p>Blower motor sluggish in operation.</p> <p><u>Mechanical</u></p> <p>Compressor clutch slipping.</p> <p>Obstructed blower passage.</p> <p>Insufficient air circulation over condenser coils; fins clogged with dirt or bug.</p> <p>Evaporator filter clogged.</p> <p><u>Refrigeration</u></p> <p>Insufficient refrigerant in system.</p>	<p>Remove blower motor for service or replacement.</p> <p>Remove clutch assembly for service or replacement, 14-24.</p> <p>Examine entire passage for obstruction. Correct as necessary.</p> <p>Clean condenser coils.</p> <p>Clean with cleaning solvent to remove cigarette tars.</p> <p>Recharge system until bubbles disappear in receiver dehydrator and gauge readings stabilize to specifications, 14-14.</p>

CHEROKEE ARROW III SERVICE MANUAL

TABLE XIV-IV. TROUBLESHOOTING CHART (AIR CONDITIONER) (CONT)

Trouble	Cause	Remedy
Excessively noisy system. (cont)	<u>Electrical</u>	
	Compressor noisy.	Check mounting and repair; remove compressor for service or replacement, 14-18.
	Compressor oil level low.	Fill with correct amount of specified oil, 14-21.
	<u>Refrigeration</u>	
	Excessive charge in system.	Discharge excess freon until high pressure gauge drops within specifications.
	Low charge in system.	Check system for leaks; charge system, 14-9 and 14-14.
	Excessive moisture in system.	Replace dehydrator, purge, evacuate, and charge system, 14-32, 14-13 and 14-14.

CHEROKEE ARROW III SERVICE MANUAL

TABLE XIV-IV. TROUBLESHOOTING CHART (AIR CONDITIONER) (cont)

Trouble	Cause	Remedy
<p>System will not produce sufficient cooling. (cont)</p>	<p><u>Mechanical</u></p> <p>Clogged screen in expansion valve.</p> <p>Expansion valve thermal bulb has lost charge.</p> <p>Clogged screen in receiver dehydrator.</p> <p>Excessive moisture in system.</p> <p>Air in system.</p>	<p>Purge system and replace expansion valve, 14-35.</p> <p>Purge system; replace expansion valve, 14-35.</p> <p>Purge system; replace receiver dehydrator, 14-32.</p> <p>Purge system; replace receiver dehydrator, 14-32.</p> <p>Purge, evacuate and charge system, 14-13 and 14-14. (Replace receiver dehydrator, 14-32.)</p>
<p>Excessive noisy system.</p>	<p><u>Electrical</u></p> <p>Defective winding or improper connection in compressor clutch coil.</p> <p><u>Mechanical</u></p> <p>Loose or excessively worn drive belts.</p> <p>Noisy clutch.</p>	<p>Replace or repair as necessary, 14-24.</p> <p>Tighten or replace as required, 14-22 and 14-23.</p> <p>Remove clutch for service or replacement as necessary, 14-24.</p>

CHEROKEE ARROW III SERVICE MANUAL

TABLE XIV-V. BLOWER SYSTEM WIRE COLOR CODES

	MOTOR WIRES					AIRCRAFT WIRES	
	Pin Nos.	15920 01 General Industries	E362Q Singer Controls See Note 2	F0018a75FA Leece- Neville	Aircraft Harness	Pin Nos.	
Ground	2	Brown	Brown	Black	AC26A	2	
Low Speed	1	Red	Yellow	Yellow	Black	1	
Medium Speed	2	Black	Red	Red	White	2	
High Speed	1	Yellow	Orange	Orange	Red	1	

NOTE

1. *Pin number 1 is at the pointed side of the plug and receptacle.*
2. *YY15062 ESB-Universal Elect. Co. Motor Wire Colors Same as E362Q Singer Controls.*

CHEROKEE ARROW III SERVICE MANUAL

14-53. OXYGEN SYSTEM

WARNING

When servicing or inspecting vendor equipment installed in Piper aircraft, it is the user's responsibility to refer to the applicable vendor publication.

14-54. DESCRIPTION AND OPERATION. A fixed and/or portable oxygen system is available on this aircraft. Scott Aviation manufactures the major components for these systems and should be contacted along with the Piper Customer Service for any further information not covered herein. For specific parts information refer to the Piper Parts Catalog.

The fixed oxygen system involves a 48.3 cu. ft. cylinder tied into four overhead "shallow wall" outlets and a "push-pull" regulator control mechanism. A 3AA 1800 tank, mounted in the modified tail cone behind the baggage compartment, is connected to an external fill valve mounted to the fuselage behind fuselage station bulkhead 191.0. The manifold for the outlets is set up such that the main feed line for the overhead outlets is connected to the left rear passenger outlet from which the right rear and pilot outlets are connected. The copilot outlet is connected to the right rear passenger outlet. Push-pull control is provided by a knob on the overhead panel, to the left of the fresh air duct control. A gauge for displaying tank pressure is mounted in the overhead duct behind the passengers and is lighted by a post light.

The portable oxygen system uses a 22 cu. ft. capacity, 3AA 1800 cylinder. The tank is incorporated in a carrying case which utilizes a dual manifold, permitting four masks to be used with dual connectors at each outlet. The portable unit fits in the cradle between the back passenger seats.

Refer to pilot's operating handbook for operating instructions.

WARNING

Use only aviation breathing oxygen when recharging the bottle. MIL-0-27210C specifies that the moisture content of aviation breathing oxygen must not exceed 0.005 milligrams of water vapor per liter of gas at a temperature of 70 degrees F° and a pressure of 760 millimeters of mercury.

WARNING

DO NOT use grease or any type of oil on any hardware connected to the oxygen system. When working with an oxygen system, ensure that your hands, clothing, tools, and immediate area is clean and free of any grease or oil.

WARNING

Oxygen cylinders are identified by the ICC or DOT identification stamped on the cylinder. The standard weight cylinder (ICC or DOT 3AA 1800) must be hydrostatic tested at the end of each 5 year period. Lightweight cylinders (ICC or DOT 3HT 1850) must be tested every 3 years and after 4380 refills or 24 years whichever comes first, be replaced. The month and year of the last test is stamped on the cylinder beneath the ICC, DOT identification.

CHEROKEE ARROW III SERVICE MANUAL

14-55. TROUBLESHOOTING. (Refer to Table XIV-VI)

14-56. FIXED OXYGEN SYSTEM.

14-57. INSPECTION AND MAINTENANCE. Due to the nature of the process used to test compressed gas tanks, servicing and hydrostatic tests must be conducted by a DOT or manufacturer (Scott Aviation) approved shop. The following material gives recommended inspection and maintenance information for the various parts of the oxygen systems.

1. Check outlets for leakage both in the use and non-use condition, and for leakage around an inserted connector. For leak testing information, refer to the appropriate subject in this chapter.
2. Check the high pressure gauge for accuracy by comparing its indicated pressure with that of a gauge of known accuracy, connected to the fill port.
3. Inspect tank for dents, bulges, corrosion, and major strap chafing marks. Should any of these problems exist, the tank should be removed and hydrostatically tested.
4. An operational check of the regulator is accomplished as follows: (Refer to Figure 35-3.)
 - a. Interconnect a sensitive pressure gauge of a range of 0 to 100 psi, with a Scott Aviation 857000 plug-in, and connect the apparatus to the pilot's outlet in the overhead panel. It is recommended that a hose of 1/4 in. ID x 1/2 in. OD and 18 inches long be used.
 - b. Interconnect a pneumatic flow apparatus of a range of 0-5 liters per min (1 pm.) with a Scott Aviation 8570-00 plug-in. Use the same hose dimension as explained in the last step. Connect the flow apparatus to the copilot's outlet.
 - c. Insert a Scott plug-in in each of the other outlets and pull the oxygen control knob to the on position. The pressure and flow should be 55 to 80 psi and 3.3 to 5.31 pm. respectively at sea level.
 - d. There should be no external leakage anywhere on the regulator when it is turned off and all fittings should be leak free.
5. Check airframe logbook for last maintenance of oxygen system and perform as required per Chart 3502.
6. Test the oxygen for odor. Pure oxygen is odorless and tasteless. Any system having a significant odor present in the gas should be purged and the bottle replaced or removed and purged.
7. Any fittings, connector, and tubes which have imperfect threads, pitted or disfigured cones, or other damage should be replaced.

WARNING

Oxygen tubes must not be clamped to or supported by electrical wire bundles, hydraulic, pneumatic, or any other type of lines. They should be separately clamped to bulkhead and stringers, with minimum 1/8 inch separation.

8. Check plumbing for kinking, cracks, gouges, dents, deep scratches, or other damage, and replace as necessary.
9. Make sure to check the oxygen lines for proper clearance as follows:
 - a. Two inch minimum between oxygen tubes and all flexible moving parts of the aircraft (flexible control cables, etc). If adequate space cannot be attained, protection from chafing must be provided.
 - b. At least 1/2 inch minimum between oxygen tubes and all rigid moving parts of aircraft, such as levers and rigid control rods.
 - c. Six inch minimum separation between oxygen tubes and hydraulic, fuel, and electrical system lines and components.

CHEROKEE ARROW III SERVICE MANUAL

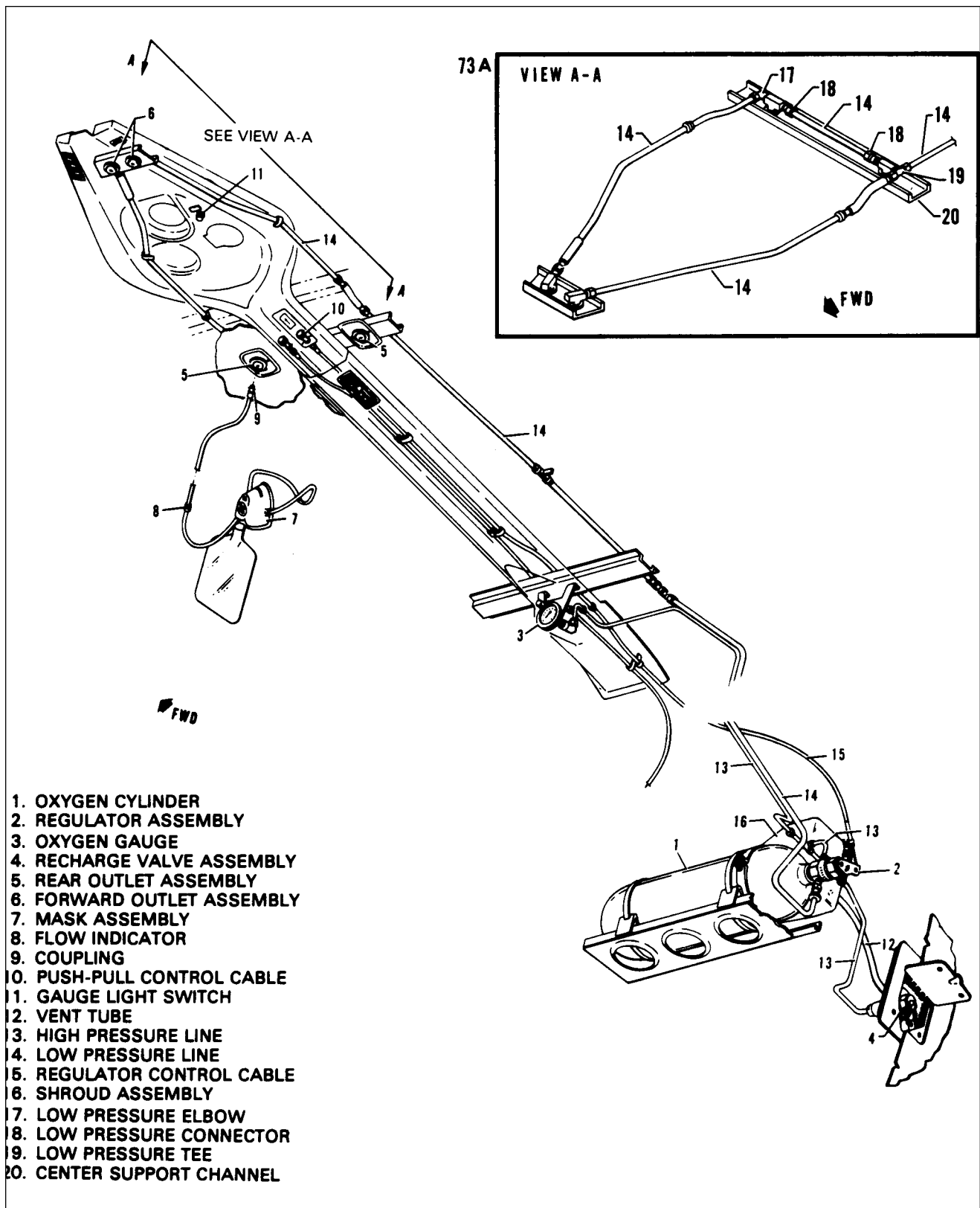
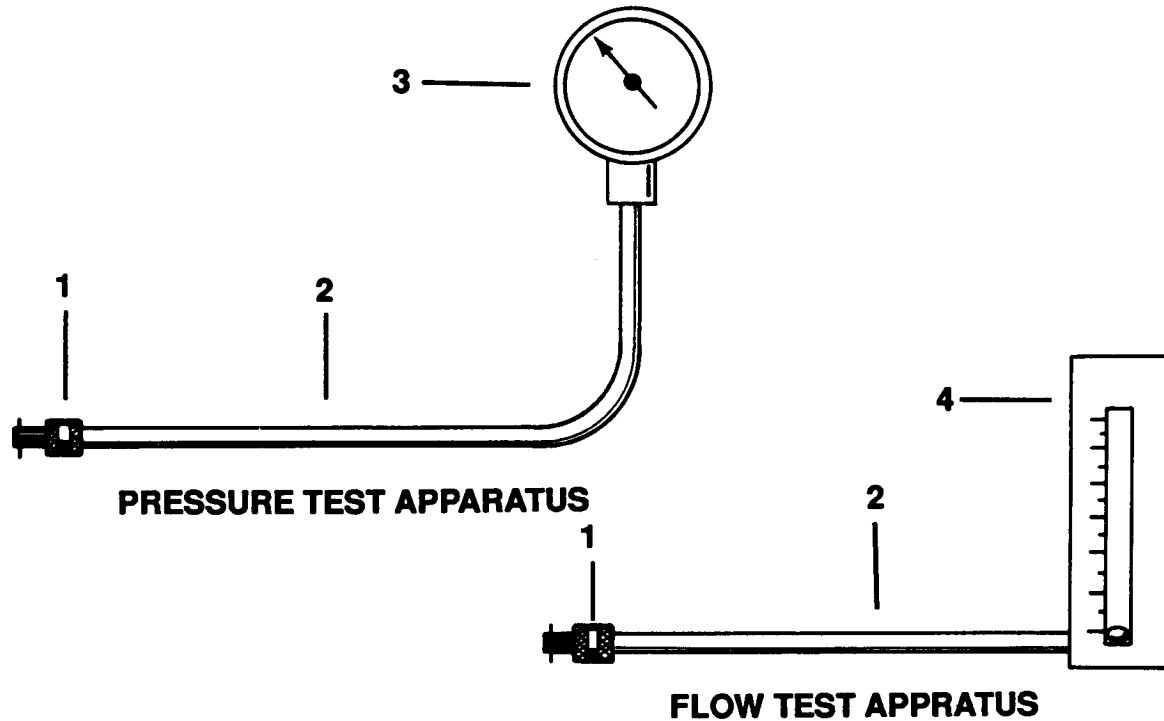

Figure 14-16. Fixed - Oxygen System

CHEROKEE ARROW III SERVICE MANUAL



1. PLUG-IN (SCOTT AVIATION PART NO. 8570-00)
2. HOSE (1/4 IN. I.D. X 1/2 IN. O.D. X 18 IN. LONG)
3. 0-100 PSI PRESSURE GAUGE (ACCURACY $\pm 2\%$)
4. MASS FLOW GAUGE (0-5 LITERS/MIN.)

Figure 14-17. Test Apparatus For Testing Oxygen System

CHEROKEE ARROW III SERVICE MANUAL

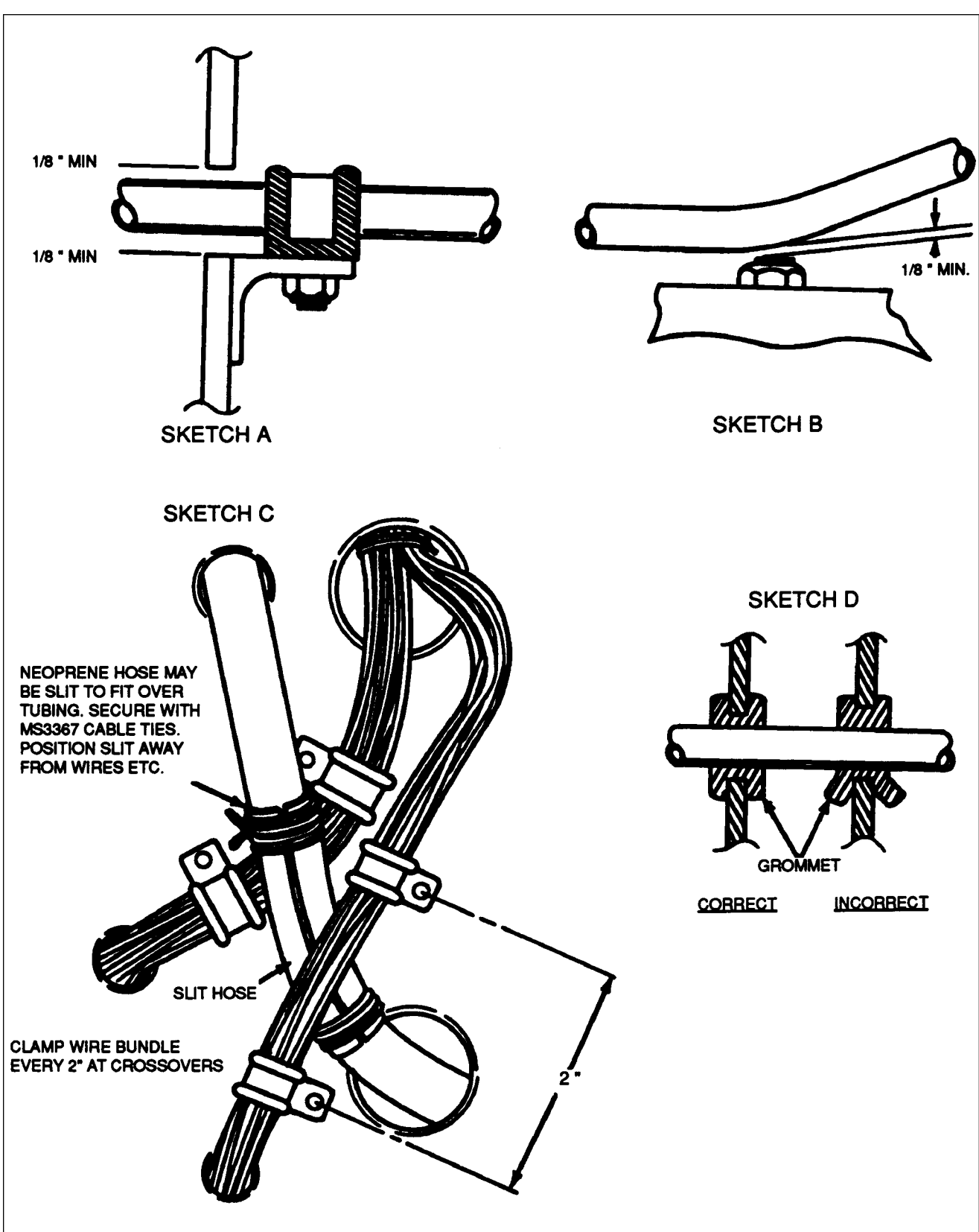

Figure 14-18. Oxygen Tubing Installation

CHEROKEE ARROW III SERVICE MANUAL

CAUTION

When the six inch requirement cannot be complied with, one inch is allowed as long as the electric cables and other lines are supported at least every two inches; and, the oxygen tube(s) is protected by rubber neoprene hose fastened in place with cable ties at the location the specific item crosses or is near the oxygen tube(s). If an item is near the oxygen tube for a certain distance, the oxygen tube for that distance must be covered.

- d. A minimum of 1/8 inch between tubing and structure adjoining the supported clamp, as shown in Figure 14-18, Sketch A.
 - e. Where a tube passes through a grommet, the tube must not bear on the grommet in any way that might cause cutting of the grommet in service as shown in Figure 14-18, Sketch D.
 - f. While in service, items may receive vibrations causing them to come in contact with other parts of the aircraft. With this in mind, low pressure tubing that is supported well enough to prevent relative motion must have at least a minimum clearance of 1/8 inch from a projection (bolt, nut, etc). Low pressure tubing that cannot be supported well enough to prevent motion must have a minimum clearance of 1/8 inch allowed after the maximum travel of the tube. High pressure lines are affected similarly but require 1/2 inch clearances. Refer to Figure 14-18, Sketch B.
10. Perform any other required maintenance as directed in AC 43.13-1A.
 11. Clean components as necessary per the following subject-paragraph.

14-58. CLEANING AND PURGING OF OXYGEN SYSTEM COMPONENTS.

CAUTION

Care and critical attention must be exercised to prevent contamination of oxygen system components by oil, grease, water, or foreign matter. Compressed air used in cleaning or flushing tubes must be clean, dry, filtered (oil free) air only.

NOTE

Solvents can be reused provided they do not become badly contaminated with oil. This condition can be determined by thoroughly evaporating 100 milliliters of the liquid in a glass dish of a determined weight. Evaporation may be accomplished by heating the dish at 200 degrees F° for one-half hour. If after evaporation and cool down, the residue exceeded 100 milligrams in weight, the solvent cannot be used for this purpose.

Three methods are recommended for cleaning oxygen system components as follows:

1. Method I
 - a. Vapor degrease affected part(s) with trichlorethylene.
 - b. Blow part(s) dry with a stream of compressed air or dry nitrogen.

CHEROKEE ARROW III SERVICE MANUAL

2. Method II.

- a. For tubing, flush with naphtha per specifications TT-N-95.
- b. Blow clean and dry off all solvent with clean, dry, filtered air.
- c. Flush with isopropyl alcohol.
- d. Rinse thoroughly with fresh water.
- e. Dry with air or by heating at temperature 250 to 300 degrees F° for one-half hour.

3. Method III.

- a. Flush with hot inhibited alkaline cleaner until free from oil and grease.
- b. Rinse thoroughly with fresh water.
- c. Dry thoroughly with a stream of clean air or by heating 250 to 300 degrees F° for one-half hour minimum.

CAUTION

Do not use adhesive tape on oxygen components for attaching or securing protective coverings. Use waxed lacing twine or tie wraps.

4. After cleaning, all tubing must be protected by caps, plugs, and/or plastic bags.
5. Before reinstallation, make sure that the fitting, tube, and fixture threads are in good condition and that the cones do not exhibit or disfigurement.

14-59. SWAGELOC FITTING INSTALLATION. (Refer to Figure 14-19.)

CAUTION

The high pressure line fitting at the regulator should be tightened until it bottoms. Ensure that Teflon thread tape is applied on all male pipe threads.

1. For swageloc fittings not preswaged or for in-aircraft installation, proceed as follows:
 - a. Turn the fitting nut onto the fitting finger tight and insert the tube until it bottoms firmly on the shoulder in the fitting.
 - b. Tighten nut with a wrench until the tube will not turn by hand.
 - c. Mark the nut at the six o'clock position.
 - d. Hold the fitting body steady with a backup wrench and tighten as follows:
 - (1) On tubing with a diameter bigger than 3/16 inch, tighten 1 1/4 turns (to the nine o'clock position).
 - (2) On tubing of 1/16, 1/8, and 3/16 inch diameter, tighten only 3/4 turn.
 - e. If nut and tube must be disconnected from the fitting, reconnect by seating the tube on the shoulder of the fitting and tightening the nut finger tight. Follow up by tightening the nut with a wrench.
2. Preswaged swageloc fittings are fabricated and installed as follows:
 - a. Assemble the nut and ferrules finger tight on the pre-swaging tool and insert tube until it firmly bottoms on the shoulder in the tool. The pre-swaging tool can be attained from Crawford Fitting Company, refer to List of Consumable Materials of this manual.
 - b. Tighten nut on fitting just enough that tube within the fitting will not turn by hand.
 - c. With a wrench, tighten the nut as follows:
 - (1) On tubing with diameters over 3/16 inch, tighten 1 1/4 turns.
 - (2) On tubing with 1/16, 1/8, or 3/16 inch diameter, tighten 3/4 of a turn.
 - d. Unscrew the nut to release the ferrule tube assembly for the tool.
 - e. The assembly is installed on the fitting as follows:

CHEROKEE ARROW III SERVICE MANUAL

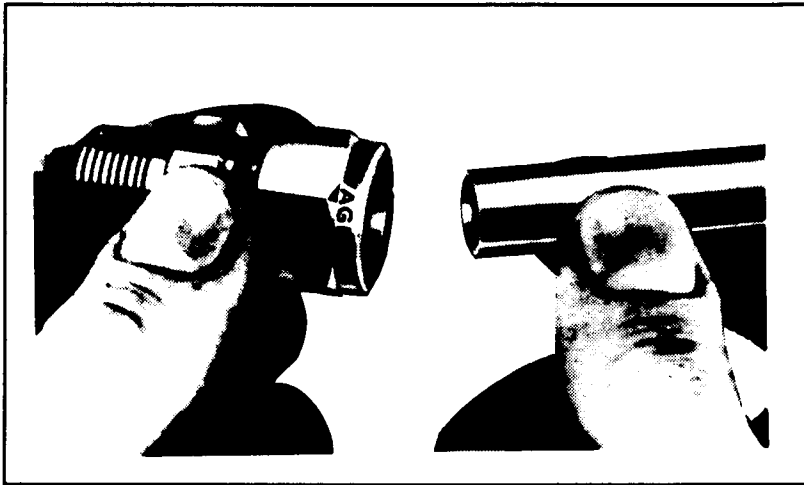

STEP 1

TURN THE FITTING NUT ONTO THE FITTING FINGER TIGHT AND INSERT THE TUBE UNTIL IT BOTTOMS FIRMLY ON THE SHOULDER IN THE FITTING.

STEP 2

MARK THE NUT AT THE SIX O'CLOCK POSITION.

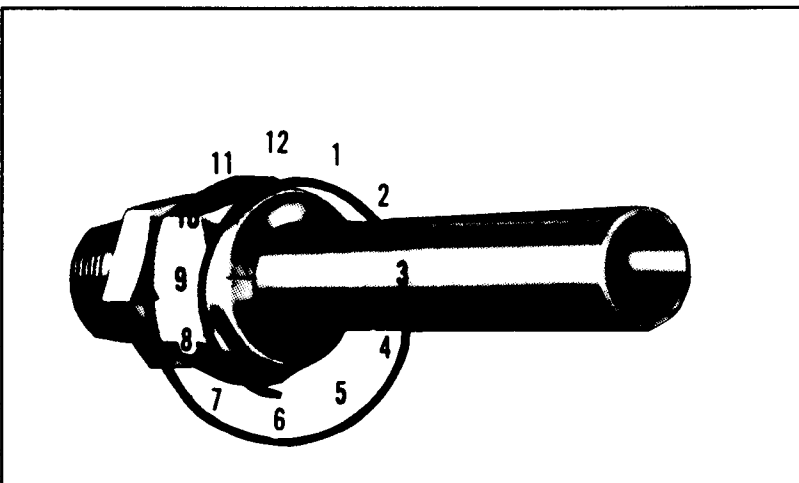
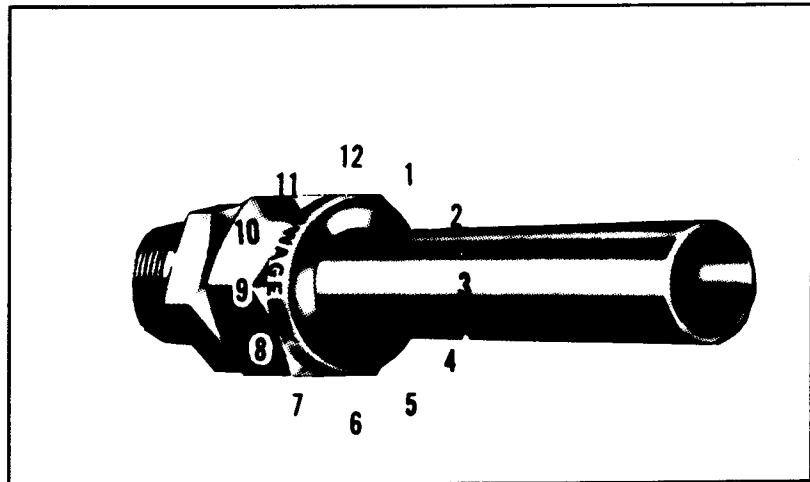

STEP 3

HOLD THE FITTING WITH A WRENCH AND TIGHTEN THE FITTING NUT AS FOLLOWS:
A. TUBING WITH A DIAMETER GREATER THAN 3/16 INCH SHALL BE TIGHTENED 1 1/4 TURNS (THE NINE O'CLOCK POSITION).

B. TUBING WITH A DIAMETER OF 1/16, 1/8, OR 3/16 INCH SHALL BE TIGHTENED ONLY 3/4 TURNS.

Figure 14-19. Installation of Swagelok Fittings

CHEROKEE ARROW III SERVICE MANUAL

- (1) Slide tube in fitting until it bottoms, turn nut to finger tight position and tighten one quarter turn with wrench.
- (2) Snug slightly with wrench.

14-60. APPLICATION OF TEFLON TAPE THREAD SEALANT. All male pipe (tapered) threads of the oxygen system should be sealed with 3M No. 48 Teflon tape. Teflon tape should not be used on straight threads. Do not use any other lubricants in place of Teflon.

1. Wrap tape on threads, starting with those farthest from the opening, in the direction of the thread spiral. Circle the threads, making sure that each side of the tape has a slight overlap.
2. Wrap the tape such that it does not extend beyond the last thread on the fitting as the opening. The tape should then be pulled until it separates. Do not cut the tape, it will not stick properly.

CHART VIII-II. OXYGEN SYSTEM LIMITS

PARTS	INSPECTION	OVERHAUL
Regulator	300 Flight Hrs.	5 Years
Pressure Gauge	300 Flight Hrs.	Replace on Condition
High Pressure Lines	300 Flight Hrs.	Replace on Condition
Low Pressure Lines	300 Flight Hrs.	Replace on Condition
Outlets	300 Flight Hrs.	Every 5 Years ¹
External Recharge Valve	Each Use	Every 5 Years ²
Masks	Each Use	Replace as Necessary
<p>NOTES:</p> <p>¹ On condition replace the rubber components in the assembly or replace assembly.</p> <p>² If the screen in front of valve is dirty, replace valve. Valve replacement is recommended every 5 years.</p>		

CHEROKEE ARROW III SERVICE MANUAL

14-61. LEAK TESTS. Solutions recommended for leak testing are Leak-Tec Formula #16-OX and that available from Scott Aviation. Refer to the List of Consumable Materials for consumer information.

1. Remove royalite covers in baggage compartment and with the oxygen system turned off, disconnect low pressure supply line and connect it to a regulated cylinder charged with dry nitrogen.

CAUTION

Whenever a leak check is performed, all fitting connections as well as other questionable areas, should be inspected.

2. Apply the leak detector solution to test surface and watch for indication of leakage.
3. Large leaks will produce bubbles immediately, but small leaks will form a white foam in 5 to 60 seconds.
4. With outlets vacated of masks, connect a test pressure gauge to the copilot's outlet. See Figure 14-17.
5. Adjust regulator on dry nitrogen cylinder for 100 psi and check for leakage at the outlets.
6. Correct any leaks and wipe off excess leak detector solution.
7. Close valve on nitrogen gas tank and insert a Scott plug-in to relieve system pressure.
8. Disconnect test gauge, plug-in, and nitrogen tank.
9. If the oxygen cylinder is not to be hooked up or installed immediately, cap and cover exposed fittings with new clean plastic bags. Temporarily support lines as needed to prevent damage. Make sure caps and coverings are as clean as possible.

14-62. OXYGEN SYSTEM COMPONENT HANDLING.

WARNING

All oxygen components must be handled carefully. Ports on regulators, indicators, and other opened components must be kept capped or plugged. Adjustments or modifications should only be initiated under direction of the FAA, Scott Aviation, and Piper Aircraft.

14-63. REMOVAL OF OXYGEN CYLINDER. (Refer to Figure 14-16.)

CAUTION

When working in tail cone, attach tail stand to tail.

NOTE

Replacement time for the recharge valve is every 5 years. If the cylinder is being removed for the 5 year test, it is recommended the valve be removed and/or replaced at the same time.

The oxygen bottle, located behind the finished bulkhead in the baggage compartment, is secured to a removable shelf mounted to each side of the fuselage. The tank is mounted such that the regulator-control valve is on the left side of the aircraft (the same side as the recharge valve). A shroud also covers the regulator end of the bottle to prevent leaks, should any develop, firm filling the aircraft with oxygen. With this in mind, a vent tube interconnects the shroud with the recharge valve fixture permitting any oxygen to vent overboard.

1. Remove screws attaching finished bulkhead to fuselage bulkhead and remove finished bulkhead.

CHEROKEE ARROW III SERVICE MANUAL

2. When working in the tail cone of the aircraft, attach a tail stand to the tail.
3. With immediate area clear of flammables (grease, hydraulic fluid, fuel) and with the oxygen system OFF, connect the mask or tube to an outlet to exhaust any pressure in the system.
4. Remove the screws and loosen clamps securing the shroud and disconnect the tube.
5. Remove the spring clamps securing vent tube to cylinder shroud and disconnect the tube.
6. Carefully separate the shroud along the high pressure lines.
7. The high pressure fitting on the regulator-control valve incorporates a valve that opens only when a line is connected to it. With this in mind, carefully unscrew the high pressure line until the pressure decreases, then remove the line. Disconnect low pressure lines as well.
8. Loosen and open the clamps securing the bottle to the shelf. Carefully move the bottle in such a way that fair access can be made to the control mechanism.

CAUTION

Be extremely careful not to kink the cable.

9. Disconnect the control cable.
10. Remove tank from the aircraft being careful not to damage the regulator-control valve.

14-64. REMOVAL OF RECHARGE VALVE. The recharge valve is located on the left rear side of the aircraft and is covered by its own access door. The valve is interconnected with the gauge line as well as the regulator control valve and is constantly under cylinder pressure as long as the high pressure line is attached to the regulator.

NOTE

The recommended service life for the recharge valve is 5 years and the oxygen cylinder must be hydrostatically tested every 5 years. It is recommended that the recharge valve be removed and replaced when the cylinder is removed for services.

1. Due to the location of the recharge valve, it is necessary to remove the oxygen cylinder. For ease of removal, it is recommended that the cylinder shelf also be removed.
2. Remove screws that secure the recharge valve's protective shroud to valve mounting dish and slide shroud back over high pressure line.
3. Unscrew high pressure line fitting from recharge valve and with somebody turning the screw from outside the aircraft, back-up the nut to remove valve.

14-65. INSTALLATION OF RECHARGE VALVE.

1. Insert valve through opening in mounting cap and align bolt holes.
2. With safety chain and information plate mounting washer aligned at one of the holes, install mounting bolts.
3. Apply Teflon tape to male threads per instructions, Section 14-60.
4. Connect high pressure line to valve and tighten fitting to a torque of 30 to 50 inch-pounds.
5. Install valve protective shroud.

CHEROKEE ARROW III SERVICE MANUAL

14-66. INSTALLATION OF OXYGEN CYLINDER.

1. Before mounting cylinder to shelf, connect control cable to control valve-regulator. If the shelf has been removed, reinstall it before continuing. Install Teflon tape per Section 14-60 application instructions.
2. Position cylinder on shelf and install pressure lines. Insert tubing into fitting until ferrule seats in fitting. Tighten nut by hand and then one quarter turn with a wrench. If fitting is relatively new, the nut might be turned 3/4 of a turn. Follow up by snuggling nut slightly with a wrench.
3. Install cylinder protective shroud and tighten clamps securing it to the tank and valve.
4. Secure cylinder to shelf by connecting and tightening clamps.
5. If vent tube has been disconnected from the shroud, make sure it is firmly attached to both the cylinder and valve shrouds.
6. Make sure all seals are properly in place in cylinder shroud. Make sure the MS35489-35 seal is in bottom of shroud where low pressure line comes through. The two seals where high pressure lines go into the shroud are MA35489-2 grommet seals.
7. Check pressure and refill bottle as necessary.
8. Inspect for leaks, especially at fittings that have been separated.

14-67. REMOVAL AND INSTALLATION OF PRESSURE GAUGE.

1. The pressure gauge is tied into the same high pressure line as the recharge valve, through a tee fitting at the tank regulator-control valve. The high pressure line connects into the valve such that it actuates a check valve permitting pressure to the line. Disconnect high pressure fitting at tank valve being careful to only unscrew it a little at a time so as to allow pressure to bleed off. Cap lines as soon as possible after removal.
2. Remove overhaul vent panel and remove instrument from bracket as follows:
 - a. Disconnect tube from fitting at rear of instrument.
 - b. Immediately cap oxygen line.
 - c. Snap off clip securing instrument in its bracket.
 - d. If the fitting on rear of instrument is to be reused, remove, clean threads, and using tape, install fitting on new gauge. Refer to instruction, Section 14-60.
3. Install gauge as follows:
 - a. With fitting installed on rear of instrument, install gauge in bracket. Make sure clip is properly secure.
 - b. Remove cap from oxygen line and with Teflon tape properly installed, connect oxygen line to fitting.
 - c. Install fitting in tank.

14-68. REMOVAL OF OUTLETS.

CAUTION

Ensure that all lines are capped after disconnection to prevent contamination.

1. Make sure oxygen system is completely turned off. Insert an oxygen mask to release pressure and ensure the system is off.
2. With a suitable spanner wrench, remove outer half of outlet.
3. Remove screws retaining trim panel and remove same.
4. The outlet can now be disconnected from the low pressure line(s). Make sure to cap lines immediately after disconnection.

CHEROKEE ARROW III SERVICE MANUAL

14-69. INSTALLATION OF OUTLETS.

1. Apply Teflon tape to male threads of the affected fitting. Refer to Section 14-60 instructions.
2. Connect outlet to low pressure line.
3. Position trim panel and secure with screws.
4. Position and secure outer half of outlet with a suitable spanner wrench.
5. Tighten fittings onto the outlets to a torque of approximately 30 in.-lb. Do not overtorque.

14-70. REMOVAL AND INSTALLATION OF OXYGEN ON/OFF CONTROL.

1. As shown in Figure 14-16, the on/off control is mounted in the overhead vent panel. To remove the control, drop the overhead panel and ducting and remove retaining nut from rear of control cable fitting.
2. Make access to the bottle, if necessary, and disconnect cable from regulator-control mechanism.
3. Cut tie wraps securing cable and pull cable from aircraft.
4. When installing a new cable, make sure new cable shield is cut to 84.0 inches long and that the core has sufficient material to make a twin loop two inches from end of shield. Install as follows:
 - a. Route cable through hole in overhead duct as shown in Figure 35-1. The wrap the cable as before.
 - b. Make sure cable properly reaches valve and install vent and panels. Connect cable to control mechanism.

14-71. REFILLING OXYGEN SYSTEM.

CAUTION

Refilling of the oxygen system should be done by qualified personnel. Before servicing the oxygen system, ensure that the aircraft is electrically grounded. Do not attempt to tighten any connections while the system is charged. Electrical equipment must not be operated while servicing the oxygen system.

For comparison of filling pressure to ambient temperatures, refer to Chart VIII-IV. The following are parameters to be followed for filling.

1. Only aviators breathing oxygen (MIL-0-27210) and appropriate filling equipment should be used to service the system.
2. If a cylinder has less than 5 psi pressure or has insufficient pressure to produce an audible hissing sound when the valve is cracked, it should be removed and/or purged. If the condition has existed for a significant length of time, the bottle must be hydrostatically tested.

CAUTION

Be cautious that there is no oil on the fittings or near the immediate vicinity.

CHEROKEE ARROW III SERVICE MANUAL

CHART VIII-IV. FILLING PRESSURE FOR CERTAIN AMBIENT TEMPERATURES

Ambient Temperature	Filling Pressure	Ambient Temperature	Filling Pressure
0	1650 (PSI)	70	1975 (PSI)
10	1700	80	2000
20	1725	90	2050
30	1775	100	2100
40	1825	110	2150
50	1875	120	2200
60	1925	130	2250

NOTE: Filling pressure are for 1850 PSI at 70°F. Table assumes 25°F rise due to heat of comprssion with max fill rate.

3. Make sure both the charge valve and recharge “cart” fittings are clean and free of contamination.
4. Attach service cart hose to recharge port. Fill system at a rate not exceeding 200 psig per minute proceeding as follows:
 - a. To obtain the correct filling pressure for the oxygen system at various ambient temperatures, a table is included for your convenience. The pressures given are not exact, but sufficiently accurate for practical purposes of working pressures between 1800 and 2400 psig cylinders. The cylinder should be allowed to cool to a stabilized temperature after filling before checking against the valves in Chart VIII-IV.
 - b. When using a recharge unit consisting of one supply cylinder, slowly open valve supply unit and allow oxygen to transfer.
 - c. When using a recharge unit consisting of two or more supply cylinders (cascade storage system), it is recommended that the following procedure be used:
 - (1) Before opening any valves, check the pressure remaining in the airplane’s oxygen cylinder. If it is partly charged, note the pressure indicated on the cylinder gauge. Then open and close each valve on the cascade storage system and determine which cylinder has the lowest pressure. When found if this cylinder has a pressure lower than the oxygen cylinder in the aircraft, do not attempt using it for filling; use the storage cylinder that has a pressure higher than the aircraft’s cylinder but lower than the others.
 - (2) Open the valve on only the one storage cylinder with the lowest pressure. When the pressure indicated on the aircraft’s oxygen gauge and charging gauge has become equal, close the valve of the storage cylinder, then go to the storage cylinder with the next higher pressure and repeat the procedure.
 - (3) If after using the last storage cylinder the aircraft’s oxygen system is still not fully charged, a full storage cylinder should be put in place of a cylinder with the lowest pressure and used in the same manner.
 - (4) A good deal of oxygen will remain in the large cylinders used in the cascade system after filling only one of the cylinders. Remaining oxygen will be a pressure something less than the 1850 psi which is not sufficient pressure to completely refill another aircraft cylinder, although it will refill several smaller cylinders.
 - (5) It is not economical even on a three or four cylinder cascade system to begin recharging with oxygen at less than 300 psi pressure in the 300 cubic foot bank of cylinders. So use 300 cubic foot cylinders down to approximately 300 psi; then return for refilling. In two cylinder systems use to approximately 100 psi; then return for filling.

CHEROKEE ARROW III SERVICE MANUAL

- d. When the pressure gauge on the recharge unit or in the aircraft reaches 1800 to 1850 psi, close the pressure regulator valve on the recharge unit. Disconnect the filler hose from the filler valve; replace the protective cap on the filler valve and close the access cover. Check the cylinder pressure according to Chart VIII-IV after the cylinder temperature stabilizes.
5. After detaching the service cart, cap hose and fittings to prevent contamination.
6. Perform a leak check of the high pressure lines and clean off solution afterwards. If solution is not properly cleaned off, unusual corrosion may result.

14-72. PORTABLE OXYGEN SYSTEM.

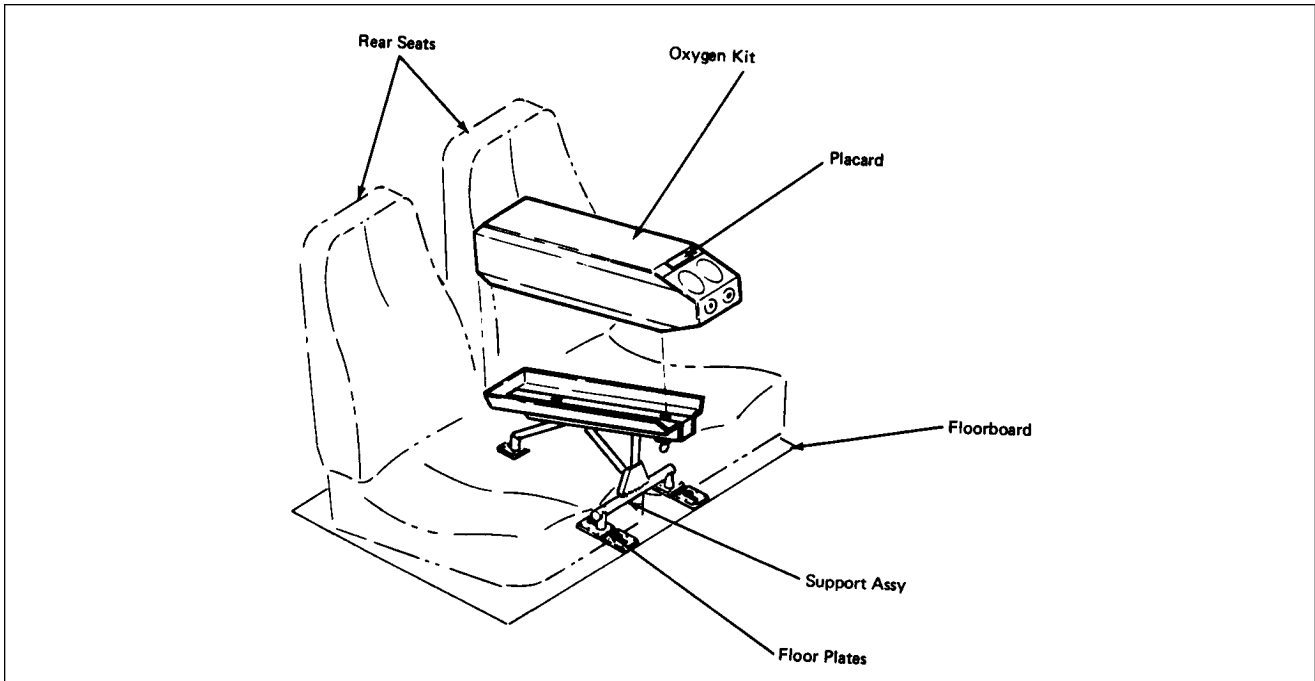

Figure 14-20. Portable Oxygen Installation

14-73. DESCRIPTION AND OPERATION. The portable oxygen system is available as one of two options that provides oxygen for the PA-28R-201T and renders it capable of cruising at higher altitudes.

The portable oxygen unit consists of a 22 cu. ft. capacity cylinder contained in a carrying case that is installed in a cradle located between the rear seats. (See figure 14-20, Portable Oxygen Installation.) The system utilizes a dual manifold, which permits 4 masks to be used, two from each single outlet using a dual connector.

CAUTION

Use only aviation breathing oxygen when having the oxygen bottle charged. MIL-0-2710C specified that the moisture content of aviation breathing oxygen must not exceed 0.005 milligrams of water vapor per liter of gas at a temperature of 70°F and a pressure of 760 millimeters of mercury.

14-74. TROUBLESHOOTING. (Refer to Table XIV-VI.)

CHEROKEE ARROW III SERVICE MANUAL

14-75. REMOVAL OF OXYGEN UNIT.

WARNING

Do not use grease or any grease type fittings on any hardware that connects to the oxygen bottle or system hardware. When working with the system make sure hands, clothing, and tools are free of oil, grease, and dirt when working with the oxygen system.

The oxygen unit can be released from its cradle by pulling down on the ring under the cradle, and sliding the unit forward, and lifting it out of the cradle.

14-76. INSPECTION AND OVERHAUL TIMES. Due to the nature of the process used to test compressed gas tanks, it is recommended that overhaul, service or hydrostatic tests be conducted by a DOT, FAA, or manufacturer (Scott Aviation) approved shop. The following checks and charts give recommended inspection and maintenance information for the various parts of the oxygen system.

WARNING

Oxygen cylinders are identified by the ICC or DOT identification stamped on the cylinder. The standard weight cylinder (ICC or DOT 3AA 1800) must be hydrostatic tested at the end of each 5 year period. Lightweight cylinders (ICC or DOT 3HT 1850) must be tested every 3 years and after 4380 refills or 24 years whichever comes first, be replaced. The month and year of the last test is stamped on the cylinder beneath the ICC, DOT identification.

1. Inspect outlets, and using directions described in the next paragraph, check leaks both in the non-use and use condition.
2. Check the pressure gauge for accuracy by removing the back section of the unit and connecting a gauge of known accuracy to the fill port.
3. Inspect tank for dents, bulges, major strap chaffing marks, or corrosion. Should any of these conditions exist, the tank should be hydrostatically tested.

TABLE XIV-VI. OXYGEN SYSTEM COMPONENT LIMITS

PARTS	INSPECTION	OVERHAUL
Regulator	300 Flight Hrs.	5 Years
Pressure Gauge	300 Flight Hrs.	5 Years
Outlets	300 Flight Hrs.	5 Years
Recharge Valve	Each Use	Replace Every 5 Yrs.
Masks	Each Use	Replace as Necessary

14-77. TESTING FOR LEAKS. Apply detector fluid Leak Tec Formula #16-OX (American Gas and Chemical Co.) solution or its equivalent. The solution should be shaken to obtain suds or foam. The suds or foam should be applied sparingly to the joints of the system. Look for traces of bubbles. Visible leakages are not permitted. Repair or replace any defective parts and retest system. With the system pressurized to service pressure, further tests can be made. All traces of the detector fluid should be wiped off at the conclusion of the examination.

CHEROKEE ARROW III SERVICE MANUAL

14-78. MAINTENANCE.

- a. Check the cylinder to be sure it is securely mounted.
- b. Check the cylinder for the ICC identification number and for the date of the last FAA inspection and test.
- c. If cylinder is completely empty, it must be completely disassembled and inspected in an FAA or manufacturer approved facility before recharging.
- d. Refer to FAA Manual AC 43.13-1A for more details.

14-79. REMOVAL OF OUTLETS.

- a. Make sure the control valve is in the full off position.
- b. Connect a mask or connector to the valve to release any pressure.
- c. Using a suitable spanner wrench, remove the outlet.
- d. The outlet can now be removed from the low pressure fitting.

14-80. INSTALLATION OF OUTLETS.

- a. Apply sealant (Permacel 412) to the male end of the fitting.
- b. Install the outlet to the regulator extension with a suitable spanner wrench.
- c. Torque the fittings into the outlets approximately 30 inch-pounds. Do not overtorque as this could damage the outlet.

14-81. PURGING OXYGEN SYSTEM. The system should be purged whenever the cylinder pressure falls below 50 psi or if any lines are left open for any length of time. Also, if the bottle is left at below 200 psi, it may develop odors from bacterial growth. This will make it necessary to purge the system. Use the following procedures:

CAUTION

When performing this operation, make sure the area is a NO SMOKING AREA and is as clean as possible of oil and dirt.

- a. Keep all doors and windows open.
- b. Connect the oxygen recharging unit to the filler valve.
- c. Plug the oxygen masks into the outlet valves and turn on the system.
- d. Set the recharging unit pressure regulator to deliver 50 psi and let the system purge for one hour. If any odor is still present, repeat the procedure for one or more hours. If the odor persists after the second purging, send unit to its manufacturer or an approved shop.

14-82. CLEANING OF FACE MASKS. The disposable masks are designed for one-time use and require no maintenance. The pilot's and copilot's mask can be cleaned as follows:

- a. Remove the microphone from the mask.
- b. Remove the sponge rubber disc from the mask turrets. Do not use soap to clean sponge rubber discs as this would deteriorate the rubber and give off unpleasant odors. Clean in clear water and squeeze dry.
- c. Wash the rest of the mask with a very mild solution of soap and water.
- d. Rinse the mask thoroughly to removal all traces of soap.
- e. Make sure the side of the breathing bag do not stick together while drying as this may decrease the life of the rubber in the bag. The mask can be sterilized with a solution of 70 percent ethyl alcohol.

CHEROKEE ARROW III SERVICE MANUAL

TABLE XIV-IV. TROUBLESHOOTING CHART (AIR CONDITIONER) (CONT)

Trouble	Cause	Remedy
No indication of pressure on pressure gauge.	Cylinder empty or leak in system has exhausted pressure. Pressure gauge or regulator defective.	Charge system and check for leaks. Return unit to manufacturer or take to approved shop.
Pressure indication normal but no oxygen flowing.	Oxygen cylinder regulator assembly defective.	Return unit to manufacturer or take to approved shop.
Offensive odors in oxygen.	Cylinder pressure below 50 psi. Foreign matter has entered the system during previous servicing.	Purge the oxygen system. See direction in this chapter.

**INTENTIONALLY LEFT BLANK
3C18 THRU 3L24**