

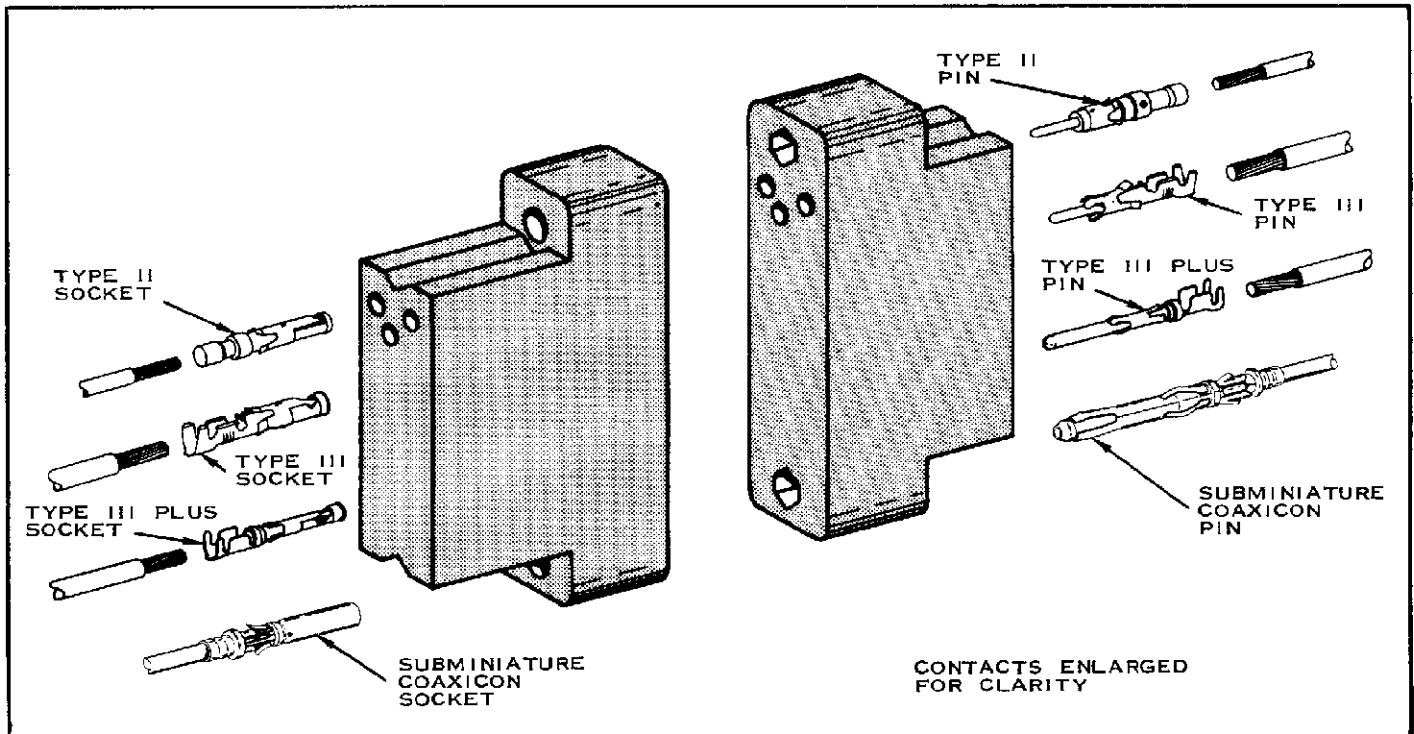

A-MP ★ 6, 14, 20 and 41 POSITION  
SERIES "M" CONNECTORS

**IS 7170**  
RELEASED 9-14-64  
REVISED 2-20-70



NUMBER OF POSITIONS	FEMALE BLOCK NUMBER	MALE BLOCK NUMBER	TYPE OF COMBINATION
6	202757-□	202756-□	M-SM
		202758-□	M-DM
14	201298-□	201297-□	M-SM
		201355-□	M-DM
20	200346-□	200345-□	M-SM
		201356-□	M-DM
41	201302-□	201301-□	M-SM
		202135-□	M-DM

FIGURE 1

1. INTRODUCTION

These instructions cover the recommended procedure for assembling the A-MP 6, 14, 20 and 41 Position Series "M" Connectors listed in Figure 1. The instruction for accessories are packaged with the specific item. Read these instructions and those packaged with the accessories before starting.

2. CONNECTOR BLOCK AND CONTACT SELECTION

Select the Male and Female Blocks from the chart in Figure 1. Note the possible combination between the connector halves.

1. First, the Female Block is Standard and accepts both Pin and Socket contacts.
2. The M-SM designation indicates a Shallow Male Block which accepts Pin contacts only.
3. The M-DM designation indicates a Deep Male Block which accepts both Pin and Socket contacts.

The A-MP Type II, III, III Plus and Subminiature COAXICON ★ Pin and Socket contacts are used in Series "M" Connector Blocks. These Contacts can be arranged to provide polarization for the Connector.

© 1964 - 1970 By AMP Incorporated. All International rights reserved. A-MP products covered by U.S. and foreign patents and/or patents pending.

**NOTE**

A-MP Keying Plugs can be inserted into the Block containing Sockets to provide polarization for the Connector. Read the instruction sheet (IS 1340) packaged with the Keying Plugs.

Using IS 1379, select the Contacts and proper Crimping Tool to be used. Crimp the Contacts using the procedure described on the instruction sheet packaged with the Crimping Tool.

### 3. ASSEMBLY PROCEDURE

The following steps indicate the proper sequence for attaching the components of the Connector Assembly to the Connector Block(s). See Figure 2.

**NOTE**

These instructions cover the application of all accessories for 6, 14, 20 and 41 Position Connectors. Therefore, some of the items will not apply to certain applications.

A. Shields and Pin Hoods are used to protect the Contacts and Wires. Place the One-Piece Shield and/or Pin Hood over the wires before inserting the Contacts.

**NOTE**

Shields and Cable Clamps are not used on 6 Position Connectors.

B. Insert Contacts as follows:

1. Push the contact into the connector cavity until it bottoms.
2. Using light pressure, pull back on the wire to make certain the contact is properly inserted.

**NOTE**

Use an insertion tool to insert contacts that are crimped to fragile wire to prevent damage to the wire. We recommend the A-MP Insertion Tool 91002-□.

C. If Turnable Jackscrews are used with Pin Hoods and/or Strain Relief Clamp, use the following procedure to attach the Jackscrew to the Connector Block.

1. Position the Pin Hood and/or Strain Relief Clamp on the Block.
2. Insert the Jackscrew Tip into the front of the Block so that it protrudes through the Mounting Hole in the Pin Hood and/or Strain Relief Clamp.
3. Slide the Body of the Jackscrew over the Tip of the Jackscrew and assemble according to the instructions (IS 1189) packaged with the Jackscrews.

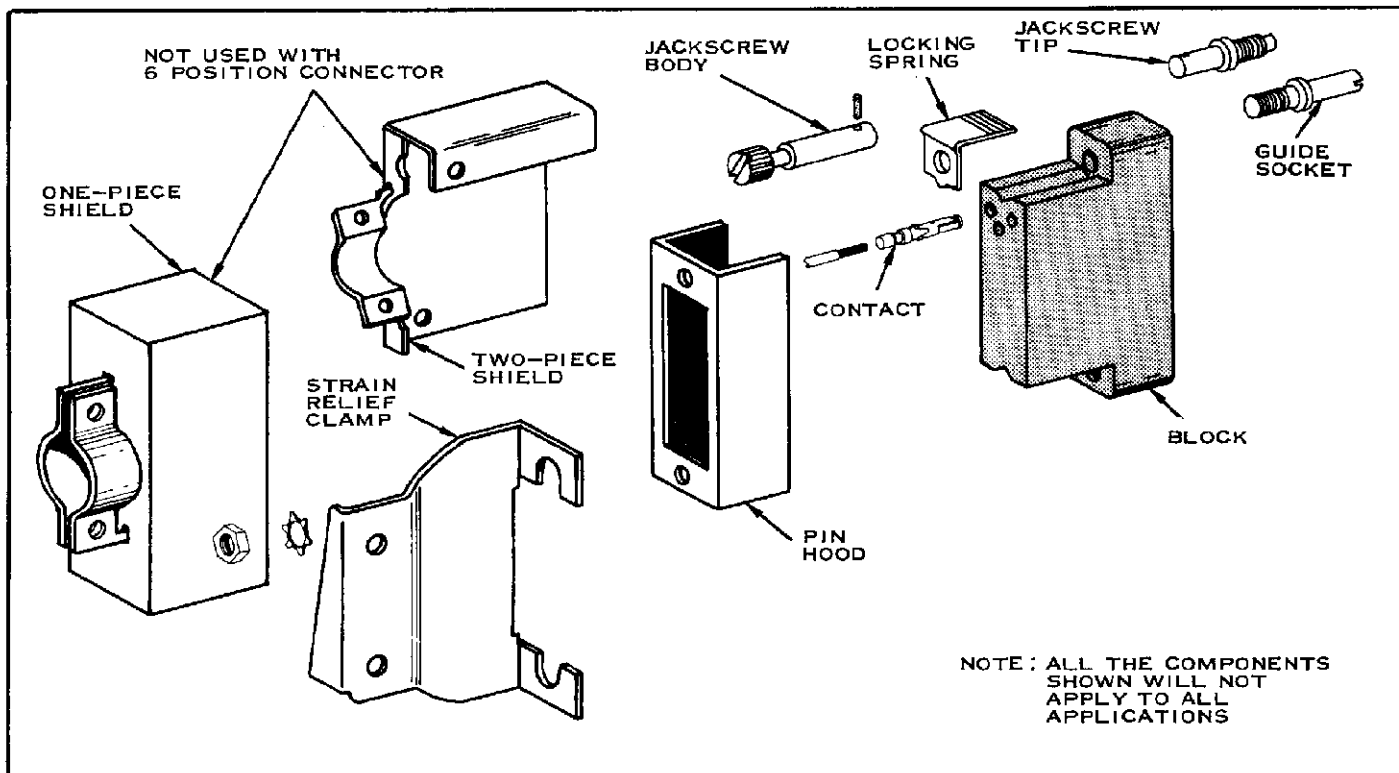

FIGURE 2

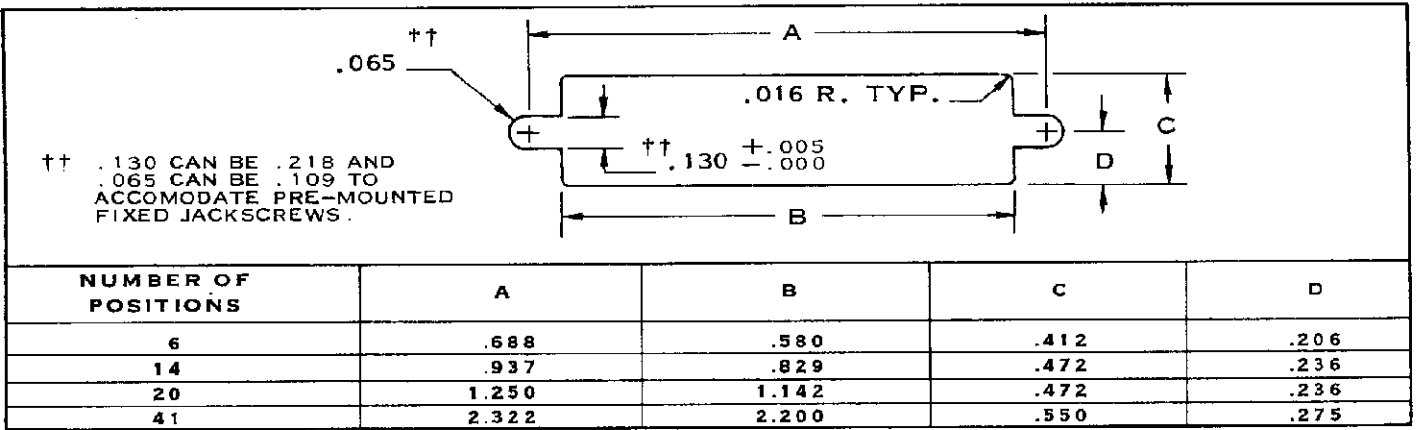

FIGURE 3

D. If Turnable Jackscrews are used with a Two-piece Shield, use the following procedure to attach the Jackscrew to the Connector Blocks.

1. Attach the Jackscrew to the Block according to the instructions (IS 1189) packaged with the Jackscrews.
2. Attach the Shield to the Block according to the instructions (IS 1192) packaged with the Shields.

E. If Locking Springs are assembled with a Pin Hood, One-piece Shield and/or Strain Relief Clamp, use the following procedure to attach them to the Connector Block.

1. Position the Locking Spring on the Block.
2. Place the Pin Hood against the Locking Spring.
3. Place the Strain Relief Clamp and/or One-piece Shield against the Pin Hood.
4. Attach these components to the Connector Block with A-MP Guide Pin Assemblies or No. 4-40 Machine Screws.
5. Attach the Strain Relief Clamp according to the instructions packaged with the specific Clamps. (See Figure 4)
6. Attach the Shield according to the instructions packaged with the specific Shields. (See Figure 4)

4. PANEL MOUNTING

To panel-mount a Connector Block, first make a cutout in the panel using the dimensions shown in Figure 3. Then mount the Block to the panel using Guide Pin Assemblies, Fixed Jackscrews or No. 4-40 Machine Screws.

INSTRUCTION		SHEETS FOR	
CONN. BLOCK (POS.)	STRAIN RELIEF CLAMP	SHIELD & CABLE CLAMP	SHIELD TYPE
6	IS 1313	---	---
14	IS 1313	IS 1296	1-PIECE-LONG 90° OUTLET
		IS 1297	1-PIECE SHORT 90° OUTLET
20	IS 7017	IS 1298	1-PIECE LONG 180° OUTLET
		IS 1312	1-PIECE SHORT 180° OUTLET
41	IS 7012	IS 1192	2-PIECE SHORT OR LONG 180° OUTLET
		IS 1297 IS 7026	1-PIECE SHORT 90° OUTLET

FIGURE 4

NOTE

If applicable, prepare cutout for Pin Hood-Mounting Bracket as shown in Figure 5.

5. CONTACT EXTRACTION

Use an extraction tool to remove the contacts from the Connector Block. We recommend the A-MP Extraction Tool 305183. Read the instructions (IS 1216) packaged with the Tool.

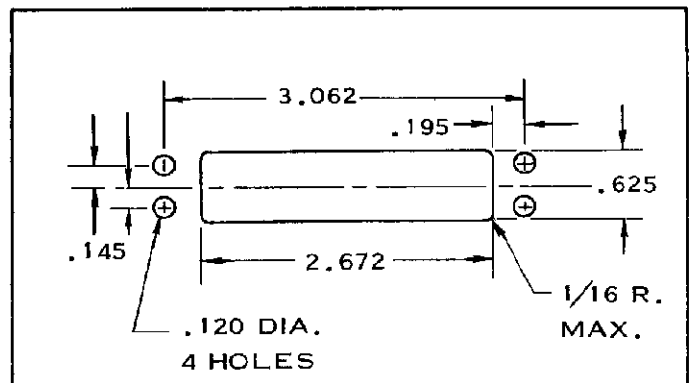

FIGURE 5