

THIS DRAWING IS UNPUBLISHED. RELEASED FOR PUBLICATION  
 BY AMP INCORPORATED. ALL RIGHTS RESERVED.

LOC	DIST	REVISIONS					
DF	DO	P	LTR	DESCRIPTION	DATE	DWN	APVD
		0		RELEASED	4-00	CT	RG
		A		EC 063D-0267-01 JM	1-02	DBK	JM

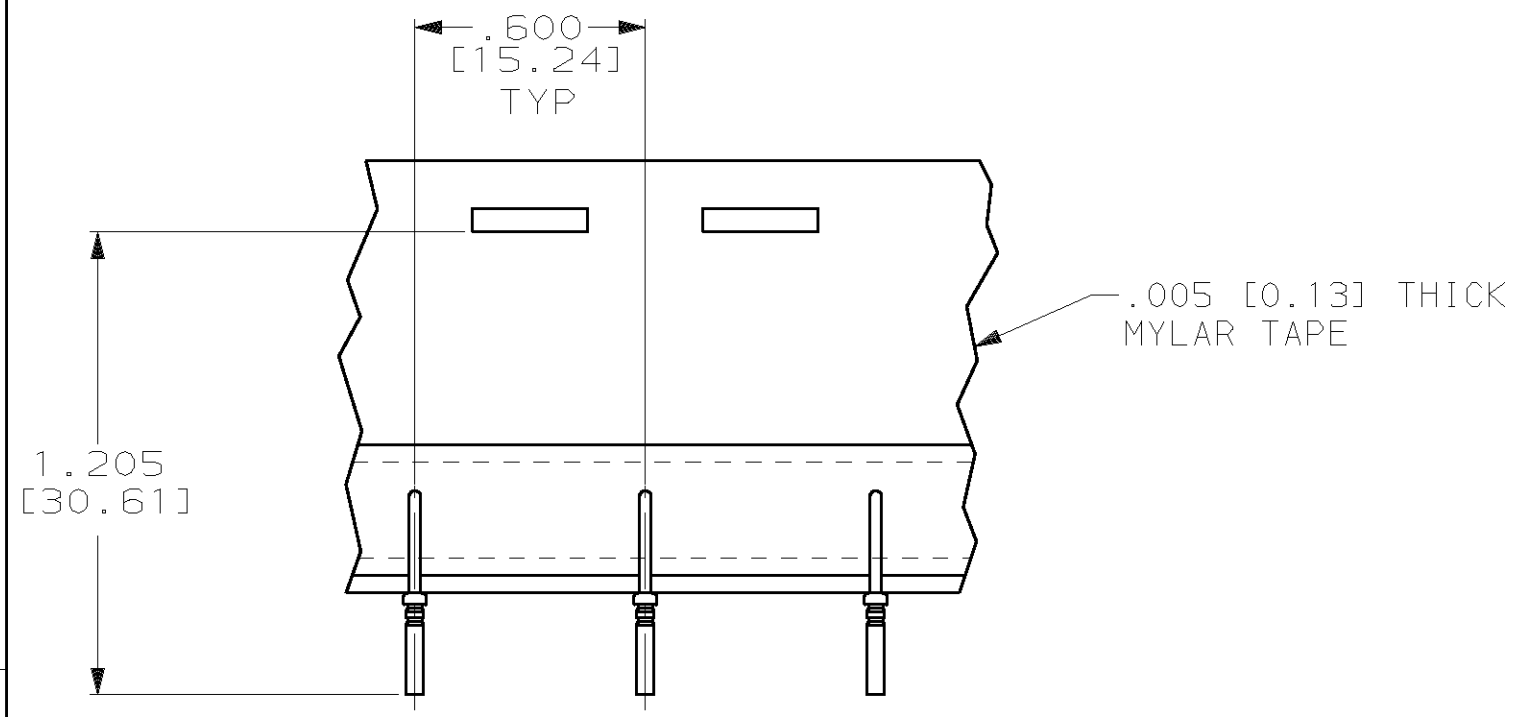

TAPE MOUNTED  
 1218699-2 ONLY  
 SCALE 2:1

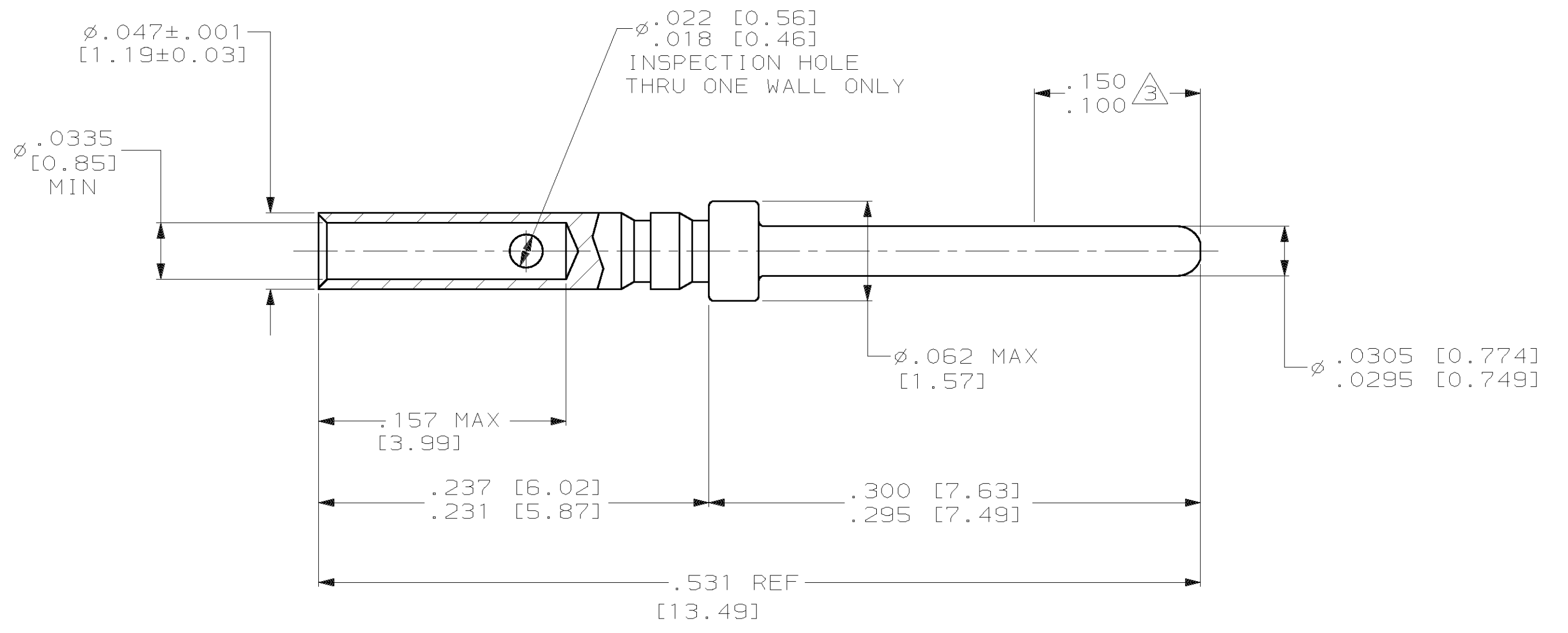

- MATERIAL: BRASS PER ASTM-C34500.
- FINISH: GOLD PLATED .000050 [0.00127] MIN THICK OVER NICKEL PLATE .000050 [0.00127] MIN THICK.
- POINT OF PLATING THICKNESS MEASUREMENT.
- WIRE BARREL WILL ACCEPT #22-28 AWG WIRE.
- CRIMPING TOOL: USE M53198-1 WITH APPLICABLE POSITIONER.
- INSERTION/EXTRACTION TOLL: AMP PART NO. 91067-1.
- FINISH: GOLD PLATED .000030 MIN THK OVER NICKEL UNDERPLATE .000050 MIN THK

FINISH	DESCRIPTION	PART NUMBER
?	LOOSE PIECE	1218699-3
2	ON TAPE	1218699-2
2	LOOSE PIECE	1218699-1

THIS DRAWING IS A CONTROLLED DOCUMENT.

DWN	C.C. THOMAS	4/17/00
CHK	R. GROSS	4/17/00
APVD	R. GROSS	4/17/00

AMP Incorporated  
 Harrisburg, PA 17105-3608

PIN CONTACT, SIZE 22D, AMPLIMITE

SIZE	A2	CAGE CODE	00779	DRAWING NO	1218699	RESTRICTED TO	-
SCALE	15:1	SHEET	1	OF	1	REV	A

1218699