



GTX 3X5 Transponder TSO Installation Manual



© 2015-2016 Garmin International, Inc. or its subsidiaries
All Rights Reserved

Except as expressly provided herein, no part of this manual may be reproduced, copied, transmitted, disseminated, downloaded or stored in any storage medium, for any purpose without the express prior written consent of Garmin. Garmin hereby grants permission to download a single copy of this manual and of any revision to this manual onto a hard drive or other electronic storage medium to be viewed and to print one copy of this manual or of any revision hereto, provided that such electronic or printed copy of this manual or revision must contain the complete text of this copyright notice and provided further that any unauthorized commercial distribution of this manual or any revision hereto is strictly prohibited.

© 2016 Bluetooth® word mark and logos are registered trademarks owned by Bluetooth SIG, Inc. and any use of such marks by Garmin is under license. Other trademarks and tradenames are those of their respective owners.

CherryMAX is a registered trademark of Cherry Aerospace Fasteners, a division of Textron, Inc.

Garmin® is a registered trademark of Garmin International or its subsidiaries. Connex™, GDU™, and GTN™ are trademarks of Garmin International or its subsidiaries. These trademarks may not be used without the express permission of Garmin.

© 2016 SiriusXM Radio Inc. Sirius, XM, and all related marks and logos are trademarks of SiriusXM Radio Inc. All other marks and logos are property of their respective owners. All rights Reserved.

Skywatch® is a registered trademark of L-3 Communications.

Windows® is a registered trademark of Microsoft Corporation in the United States and other countries.

All other product or company names that may be mentioned in this publication are trade names, trademarks, or registered trademarks of their respective owners.

At Garmin, we value your opinion. For comments about this guide, please e-mail Techpubs.Salem@garmin.com. For comments about Garmin aviation products, email Avionics@garmin.com.

Refer to Garmin's website for information about the [Aviation Limited Warranty](#).

Garmin International Inc.
1200 E. 151st Street
Olathe, Kansas 66062 USA
Telephone: (913) 397-8200
Aviation Dealer Technical Support Line (Toll Free): (888) 606-5482
Website Address: www.garmin.com

Garmin AT, Inc.
2345 Turner Rd. SE
Salem, OR 97302 USA
Telephone: (503) 581-8101
Fax: (503) 364-2138
Email: support.salem@garmin.com

Garmin (Europe) Ltd.
Liberty House, Hounslow Business Park
Southampton, Hampshire SO40 9LR U.K.
Phone: +44 (0) 23 8052 4000
Fax: +44 (0) 23 8052 4004
Aviation Support +44 (0) 370 850 1243

RECORD OF REVISIONS

Revision	Revision Date	Subject
2	12/14/15	Reorganized manual.
3	2/11/16	Rewrote for clarity. Refer to current revision description.
4	2/26/2016	Added information for vertical remote mount and other minor edits. Refer to current revision description.

CURRENT REVISION DESCRIPTION

Section	Description
1.8	Added backplate and updated weights in table 1-3.
	Added vertical remote mount characteristics to table 1-4.
1.14	Added GPS Boot Block to table 1-12.
3.2	Added vertical remote mount to table 3-1.
3.3	Added vertical remote mount to table 3-2.
3.4.3	Added "GTX 3X5 Vertical Remote Mount" section.
4.7.2	Added "Standard" to heading.
4.7.3	Added "Vertical Remote Mount Units" section.
4.9	Added "Vertical Remote Mount Unit Installation and Removal" section.
Appendix B	Added "GTX 3X5 Vertical Remote Mount" as figure B-5.
	Added "GTX 3X5 Vertical Remote Mount Dimensions and CG" as figure B-6.
Appendix D	Updated figure D-3.
	Updated note 1 of figure D-10.
	Renamed figure D-16 to "Altitude Source Interconnect."
	Added note 6 to figure D-16.
	Updated figure D-17.

INFORMATION SUBJECT TO EXPORT CONTROL LAWS

This document may contain information which is subject to the Export Administration Regulations (EAR) issued by the United States Department of Commerce (15 Code of Federal Regulations (CFR), Chapter VII, Subchapter C) and which may not be exported, released, or disclosed to foreign nationals inside or outside of the United States without first obtaining an export license. A violation of the EAR may be subject to a penalty of up to 10 years imprisonment and a fine of up to \$1,000,000 under section 2410 of the Export Administration Act of 1979. Include this notice with any reproduced portion of this document.

DEFINITIONS OF WARNINGS, CAUTIONS, AND NOTES



WARNING

A warning means injury or death is possible if the instructions are not obeyed.



CAUTION

A caution means that damage to the equipment is possible.



NOTE

A note gives more information.



WARNING

This product's packaging and components contain chemicals known to the State of California to cause cancer, birth defects, or reproductive harm. This notice is provided in accordance with California's Proposition 65. If you have any questions or would like additional information, please refer to Garmin's website, www.garmin.com/prop65.



WARNING

*Perchlorate Material – special handling can apply.
Refer to www.dtsc.ca.gov/hazardouswaste/perchlorate.*



NOTE

All screen shots used in this document are current at the time of publication. Screen shots are intended to provide visual reference only. All information depicted in screen shots, including software file names, versions, and part numbers, are subject to change.

TABLE OF CONTENTS

1	SYSTEM OVERVIEW	1-1
1.1	Scope	1-2
1.2	Equipment Description.....	1-3
1.3	Definitions and Abbreviations.....	1-4
1.4	ADS-B Capabilities	1-6
1.5	FIS-B Capabilities	1-6
1.6	TIS System Capabilities	1-7
1.7	Interface Summary	1-7
1.8	General Specifications.....	1-8
1.9	Transponder Specifications	1-10
1.10	UAT Receiver Specifications (GTX 345 Only).....	1-10
1.11	1090 MHz Receiver Specifications	1-11
1.12	GPS Specifications (Units with Internal GPS Only).....	1-11
1.13	Power Specifications	1-12
1.14	Certification.....	1-13
1.15	License Requirements	1-16
1.16	Reference Documents.....	1-17
2	LIMITATIONS	2-1
2.1	HSDB Packet Forwarding	2-1
2.2	ARINC 429 Data Concentrator Function	2-1
3	INSTALLATION OVERVIEW	3-1
3.1	Introduction	3-2
3.2	Unit Configurations.....	3-2
3.3	Accessories Supplied.....	3-3
3.4	Optional Accessories	3-5
3.5	Necessary Installation Materials and Accessories Not Supplied	3-7
3.6	Necessary Special Tools.....	3-7
3.7	Transponder Antenna	3-8
3.8	GPS Antenna Requirements	3-9
3.9	Minimum Systems Configuration	3-10
3.10	GTX Input Source Priority	3-11
3.11	GPS/SBAS Parameters.....	3-20
3.12	Antenna Considerations	3-21
3.13	Electrical Bonding.....	3-24
3.14	Cabling and Wiring	3-24
3.15	Electrical Bonding Considerations	3-24
3.16	Cooling Requirements and Considerations	3-24
4	INSTALLATION PROCEDURE	4-1
4.1	Wire Harness Installation	4-1
4.2	Backshell Assembly Parts	4-2
4.3	Shielded Cable Preparation	4-3
4.4	Connector and Backshell Assembly.....	4-5
4.5	Configuration Module Installation	4-8
4.6	Coax Cable Installation	4-10
4.7	Equipment Rack Installation	4-11

TABLE OF CONTENTS CONTINUED

4.8	Panel and Standard Remote Mount Unit Installation and Removal.....	4-12
4.9	Vertical Remote Mount Unit Installation and Removal.....	4-13
5	CONNECTOR PINOUT INFORMATION	5-1
5.1	Main Board Connector - P3251.....	5-2
5.2	ADS-B Board Connector – P3252 (GTX 345 Only)	5-5
5.3	Power.....	5-6
5.4	Lighting Bus	5-7
5.5	Altitude Inputs.....	5-7
5.6	Discrete I/O	5-8
5.7	Serial Data Interfaces	5-9
5.8	Suppression Bus	5-10
5.9	OAT Input	5-10
5.10	Audio Output.....	5-11
5.11	Time Mark.....	5-11
5.12	Configuration Module.....	5-11
5.13	USB Interface	5-12
6	POST INSTALLATION CONFIGURATION AND CHECKOUT	6-1
6.1	System Configuration Overview	6-1
6.2	Mounting, Wiring, and Power Checks	6-1
6.3	Configuration Mode and Settings.....	6-2
6.4	Audio Settings	6-3
6.5	Interfaces	6-5
6.6	Unit Settings	6-14
6.7	Display Pages	6-17
6.8	Sensors.....	6-20
6.9	ADSB	6-25
6.10	Diagnostics	6-30
6.11	Remote Unit Configuration.....	6-32
6.12	Ground Check - GPS Reception Check	6-40
6.13	Software Installation Procedure	6-41
7	CONTINUED AIRWORTHINESS	7-1
APPENDIX A DATA FORMATS		A-1
A.1	RS-232 Air Data Input Format.....	A-1
APPENDIX B GTX 3X5 MECHANICAL DRAWINGS		B-1
APPENDIX C EQUIPMENT COMPATIBILITY AND CONFIGURATION		C-1
C.1	ADS-B In Displays.....	C-2
C.2	GPS Sources	C-3
C.3	Altitude Sources	C-4
C.4	Audio Panels.....	C-5
C.5	Radar Altimeters.....	C-6
C.6	Heading Reference Sources.....	C-6
C.7	Traffic Sensors (GTX 345 Only).....	C-8
C.8	Bluetooth	C-9
C.9	Remote Control	C-9

TABLE OF CONTENTS CONTINUED

C.10 TIS-A Display C-10

APPENDIX D INTERCONNECT DRAWINGSD-1

LIST OF FIGURES

Figure 3-1	Air Data Discrete Priority Order.....	3-11
Figure 3-2	Pressure Altitude Priority Order.....	3-12
Figure 3-3	GPS Locations of Antennas.....	3-23
Figure 4-1	Shielded Cable Preparation.....	4-4
Figure 4-2	Shield Termination on Backshell Assembly.....	4-6
Figure 4-3	Connector and Backshell Assembly.....	4-7
Figure 4-4	Configuration Module Installation.....	4-9
Figure 6-1	Audio Group.....	6-3
Figure 6-2	Audio Page.....	6-4
Figure 6-3	Audio Page 2.....	6-4
Figure 6-4	Audio Page 3.....	6-4
Figure 6-5	Interface Group.....	6-5
Figure 6-6	RS-232 Interface Page.....	6-7
Figure 6-7	RS-422 Output Page.....	6-8
Figure 6-8	A429 In Page.....	6-9
Figure 6-9	A429 Output Page.....	6-10
Figure 6-10	HSDB Interface Page.....	6-11
Figure 6-11	Discrete In Page.....	6-12
Figure 6-12	Discrete Out Page.....	6-13
Figure 6-13	Unit Group.....	6-14
Figure 6-14	FIS-B Processing Page.....	6-14
Figure 6-15	Altitude and Temperature Units Page.....	6-15
Figure 6-16	Installation and VFR ID Page.....	6-15
Figure 6-17	Altitude Alert Deviation and Restore Page.....	6-16
Figure 6-18	Bluetooth Page.....	6-16
Figure 6-19	Display Group.....	6-17
Figure 6-20	Display Pages.....	6-18
Figure 6-21	Sensor Group.....	6-20
Figure 6-22	Sensor Page.....	6-21
Figure 6-23	Altitude Source Page.....	6-21
Figure 6-24	Source, Integrity, and Offset Page.....	6-23
Figure 6-25	Internal Alt Encoder Page.....	6-23
Figure 6-26	Internal Alt Encoder Adjustment Page.....	6-23
Figure 6-27	Setting the Yaw Angle.....	6-24
Figure 6-28	Internal AHRS Orientation Page.....	6-24
Figure 6-29	ADS-B Group.....	6-25
Figure 6-30	Aircraft Category and Max Airspeed Page.....	6-26
Figure 6-31	Aircraft Length and Width Page.....	6-27
Figure 6-32	1090ES Out Control and UAT Out Remote Control Page.....	6-27
Figure 6-33	1090ES In Capable and UAT In Capable Page.....	6-27
Figure 6-34	ADS-B In Processing Page.....	6-28
Figure 6-35	Aircraft Tail Number and Address Page.....	6-28
Figure 6-36	Allow Pilot to Edit Flight ID Page.....	6-28
Figure 6-37	Default Flight ID and Flight ID Prefix Page.....	6-29
Figure 6-38	Diagnostics Group.....	6-30
Figure 6-39	Diagnostics Page.....	6-31
Figure 6-40	USB-A and USB-B Connectors.....	6-32
Figure 6-41	Aircraft Configuration Page.....	6-33

LIST OF FIGURES CONTINUED

Figure 6-42	Airframe Configuration Page	6-33
Figure 6-43	Unit Configuration Page	6-34
Figure 6-44	Interface Configuration Page - Serial	6-34
Figure 6-45	Interface Configuration Page - A429	6-35
Figure 6-46	Interface Configuration Page - Discretes	6-35
Figure 6-47	Interface Configuration Page - HSDB	6-36
Figure 6-48	Sensors Configuration Page - GAE	6-36
Figure 6-49	Sensors Configuration Page - GPS	6-37
Figure 6-50	Sensors Configuration Page - Internal AHRS	6-37
Figure 6-51	Sensors Configuration Page - Additional Sensors	6-38
Figure 6-52	Audio Configuration Page	6-38
Figure 6-53	Display Configuration Page - Panel Mount Units Only	6-39
Figure 6-54	Software Upload Page	6-41
Figure B-1	GTX 345 GPS Panel Mount Assembly Shown	B-2
Figure B-2	GTX 345 GPS Panel Mount Dimensions and CG Shown	B-3
Figure B-3	GTX 345R GPS Standard Remote Mount Assembly Shown	B-4
Figure B-4	GTX 345R GPS Standard Remote Mount Dimensions and CG Shown	B-5
Figure B-5	GTX 3X5 Vertical Remote Mount	B-6
Figure B-6	GTX 3X5 Vertical Remote Mount Dimensions and CG	B-7
Figure B-7	G1000 Mount Rack Assembly with GTX 345R GPS Shown	B-8
Figure B-8	G1000 Mounting Rack Dimensions and CG with GTX 345R GPS Shown	B-9
Figure B-9	GTX 3X5 Panel Cutout Detail	B-10
Figure B-10	GTX 3X5 Connector and Vent Locations	B-11
Figure B-11	Optional Garmin Altitude Encoder	B-11
Figure D-1	GTX 3X5 Power Configuration Typical Interconnect	D-3
Figure D-2	GTX 345 - Legacy G1000 Interconnect	D-5
Figure D-3	GTX 335 - Legacy G1000 Interconnect	D-7
Figure D-4	GTX 3X5 - GNS 480 (CNX80) Interconnect	D-8
Figure D-5	GTX 335 - GTN 6XX/7XX Typical Interconnect	D-9
Figure D-6	Single/Dual GTX 335 - Single GTN 6XX/7XX Interconnect	D-11
Figure D-7	GTX 345 - GTN 6XX/7XX Typical Interconnect	D-12
Figure D-8	GTX 345 - Single/Dual GTN 6XX/7XX Interconnect	D-14
Figure D-9	GTX 335/345 - GDL 88 Interconnect	D-16
Figure D-10	GTX 345 - Traffic Sensor Interconnect	D-17
Figure D-11	GTX 345 - Single and Dual 400W/500W Series	D-18
Figure D-12	GTX 3X5 - Audio Interconnect	D-19
Figure D-13	GTX 3X5 - Radio Altimeter Interconnect	D-20
Figure D-14	GTX 3X5 - AHRS/Heading Source	D-21
Figure D-15	GTX 3X5 - Switches and OAT Probe Interconnect	D-22
Figure D-16	GTX 3X5 - Altitude Source Interconnect	D-23
Figure D-17	GTX 335 - GNS 400W/500W Series Interconnect	D-25
Figure D-18	GTX 345/345R - Flight Stream Interconnect	D-26
Figure D-19	GTX 345 - MX20/GMX 200 Interconnect	D-26
Figure D-20	GTX 335 - GDU 620 Interconnect	D-27

LIST OF TABLES

Table 1-1	GTX 3X5 Units.....	1-3
Table 1-2	Interface Summary.....	1-7
Table 1-3	Physical Characteristics - Panel Mount Units.....	1-8
Table 1-4	Physical Characteristics - Remote Mount Units.....	1-9
Table 1-5	Display Specifications.....	1-10
Table 1-6	Transponder Specifications.....	1-10
Table 1-7	UAT Receiver Specifications.....	1-10
Table 1-8	1090 MHz Receiver Specifications.....	1-11
Table 1-9	GPS Receiver Specifications.....	1-11
Table 1-10	Power Specifications.....	1-12
Table 1-11	TSO Compliance.....	1-13
Table 1-12	Applicable P/Ns.....	1-14
Table 1-13	TSO/ETSO Deviations.....	1-14
Table 1-14	Software Design Assurance Levels.....	1-15
Table 1-15	Complex Hardware Design Assurance Levels.....	1-16
Table 1-16	Equipment Authorization.....	1-16
Table 1-17	Garmin Reference Documents.....	1-17
Table 1-18	Additional Reference Documents.....	1-17
Table 3-1	GTX 3X5 Configurations.....	3-2
Table 3-2	Accessories Supplied.....	3-3
Table 3-3	Pressure Sensor Module.....	3-5
Table 3-4	GX000 System Rack.....	3-5
Table 3-5	GTX 3X5 Vertical Remote Mount Kits.....	3-5
Table 3-6	Recommended Crimp Tools.....	3-7
Table 3-7	Acceptable UAT/1090 Antennas.....	3-8
Table 3-8	GNSS Receiver Antennas.....	3-9
Table 3-9	Minimum System Configuration.....	3-10
Table 3-10	Compatible ADS-B Traffic/FIS-B Displays.....	3-10
Table 3-11	Air Data Select Source Priority.....	3-12
Table 3-12	Barometric Vertical Rate Source Priority.....	3-13
Table 3-13	Indicated Airspeed Source Priority.....	3-13
Table 3-14	True Airspeed Source Priority.....	3-13
Table 3-15	Barometric Pressure Setting Source Priority.....	3-14
Table 3-16	MCP/FCU Selected Altitude Source Priority.....	3-14
Table 3-17	Magnetic Heading Source Priority.....	3-15
Table 3-18	True Heading Source Priority.....	3-15
Table 3-19	Static Air Temperature Source Priority.....	3-15
Table 3-20	Total Air Temperature Source Priority.....	3-16
Table 3-21	Pressure Altitude Source Selection #1.....	3-16
Table 3-22	Pressure Altitude Source Priority Order #1.....	3-16
Table 3-23	Pressure Altitude Source Priority Order #1.....	3-17
Table 3-24	Baro-Corrected Altitude Source Selection #1.....	3-17
Table 3-25	Baro-Corrected Altitude Source Priority Order #1.....	3-17
Table 3-26	Baro-Corrected Altitude Source Priority Order #2.....	3-17
Table 3-27	AHRS Source Priority.....	3-18
Table 3-28	Airport Reference Points Source Priority.....	3-18
Table 3-29	Density Altitude Source Priority.....	3-18
Table 3-30	Height Above Terrain Source Priority.....	3-18

LIST OF TABLES CONTINUED

Table 3-31	Radio Altitude Source Priority	3-19
Table 3-32	Selected Course and Joystick Waypoint Source Priority	3-19
Table 3-33	FMS Selected Altitude Priority	3-19
Table 3-34	Magnetic Variation Source Priority	3-19
Table 4-1	Backshell Assembly	4-2
Table 4-2	Configuration Module Kit, P/N 011-00979-03	4-9
Table 5-1	P3251 Connector	5-2
Table 5-2	P3252 Connector	5-5
Table 5-3	Power Pins	5-6
Table 5-4	Power Configuration and Control Inputs	5-6
Table 5-5	Power Configuration and Power Control Functions	5-7
Table 5-6	Lighting Bus Pins	5-7
Table 5-7	Altitude Inputs	5-8
Table 5-8	Discrete Inputs and Outputs	5-8
Table 5-9	RS-232 Inputs and Outputs	5-9
Table 5-10	ARINC 429 Inputs and Outputs	5-9
Table 5-11	Ethernet Inputs and Outputs	5-10
Table 5-12	RS-422 Outputs	5-10
Table 5-13	External Suppression Bus Pin	5-10
Table 5-14	OAT Input and Output	5-10
Table 5-15	Audio Inputs and Outputs	5-11
Table 5-16	Time Mark Outputs	5-11
Table 5-17	Configuration Module Inputs and Outputs	5-11
Table 5-18	USB Inputs and Outputs	5-12
Table 6-1	RS-232 Channel 1 through Channel 3 Selections	6-6
Table 6-2	RS-232 Channel 4 Selections	6-7
Table 6-3	RS-422 Selections	6-8
Table 6-4	ARINC 429 Inputs	6-9
Table 6-5	ARINC 429 Outputs	6-10
Table 6-6	HSDB Formats	6-11
Table 6-7	Discrete Inputs	6-12
Table 6-8	Discrete Outputs	6-13
Table C-1	ADS-B In Display	C-2
Table C-2	GPS Source	C-3
Table C-3	Altitude Sources	C-4
Table C-4	Audio Panels	C-5
Table C-5	Radar Altimeters	C-6
Table C-6	Heading Reference Source	C-6
Table C-7	Traffic Sensors	C-8
Table C-8	Bluetooth	C-9
Table C-9	Remote Control	C-9
Table C-10	TIS-A Displays	C-10

1 SYSTEM OVERVIEW

1.1	Scope	1-2
1.2	Equipment Description	1-3
1.3	Definitions and Abbreviations	1-4
1.4	ADS-B Capabilities	1-6
1.4.1	ADS-B Out	1-6
1.4.2	ADS-B In	1-6
1.4.3	Installation Approval for ADS-B Systems	1-6
1.5	FIS-B Capabilities	1-6
1.6	TIS System Capabilities	1-7
1.7	Interface Summary	1-7
1.8	General Specifications	1-8
1.9	Transponder Specifications	1-10
1.10	UAT Receiver Specifications (GTX 345 Only)	1-10
1.11	1090 MHz Receiver Specifications	1-11
1.12	GPS Specifications (Units with Internal GPS Only)	1-11
1.13	Power Specifications	1-12
1.14	Certification	1-13
1.14.1	Non-TSO Functions	1-15
1.14.2	Design Assurance Levels	1-15
1.14.3	Transmitter Grant of Equipment Authorization	1-16
1.15	License Requirements	1-16
1.16	Reference Documents	1-17

1.1 Scope



NOTE

Garmin recommends installation of the GTX 3X5 by a Garmin–authorized installer. Garmin will not be liable for damages that result from improper or negligent installation of the GTX 3X5 to the extent permitted by law. Contact Garmin Aviation Product Support at (888) 606-5482 for questions.

This manual gives mechanical and electrical information to install the GTX 3X5 into an aircraft. It is not equivalent to an approved airframe-specific maintenance manual, installation design drawing, or installation data package. The content of this manual assumes use by competent and qualified avionics engineering personnel and/or avionics installation specialist using standard maintenance procedures in accordance with Title 14 of the Code of Federal Regulation and other related accepted procedures.

1.2 Equipment Description

The GTX 3X5 models include Mode S/ES transponders. Mode S/ES models have an optional internal GPS/SBAS receiver. Model names with an R indicate remote mount units. These units do not include a display or keypad.

Table 1-1 GTX 3X5 Units

Feature	GTX 335	GTX 335 NV	GTX 335 w/ GPS	GTX 335R	GTX 335R w/GPS	GTX 345	GTX 345 w/GPS	GTX 345R	GTX 345R w/ GPS
Mode S/ES	X	X	X	X	X	X	X	X	X
External ADS-B control	X	X	X			X	X		
ARINC 429 data concentrator	X	X	X	X	X	X	X	X	X
ADS-B In with alerting (UAT and 1090 MHz)						X	X	X	X
Connex (via Bluetooth)						X	X	X	X
FIS-B						X	X	X	X
TIS traffic	X	X	X	X	X				
ADS-B In and TAS/TCAS traffic integration						X	X	X	X
HSDB forwarding						X	X	X	X
Pressure sensor module (optional)	X	X	X	X	X	X	X	X	X
Flight timers	X	X	X			X	X		
Audio output	X	X	X	X	X	X	X	X	X
Interface to Garmin display products	X	X	X	X	X	X	X	X	X
Shows pressure altitude, outside air temperature, and density altitude	X	X	X			X	X		
Night vision goggle compatibility		X							
Altitude monitor	X	X	X			X	X		

1.3 Definitions and Abbreviations

Definitions

References made to GTX 3X5 apply to all GTX 3X5 models, except when noted.

The term squitter refers to a burst or broadcast of aircraft-tracking data that is periodically transmitted by a Mode S transponder without radar interrogation. The GTX 3X5 Mode S/ES models transmit ADS-B Out ES. These transmissions contain additional aircraft information that includes GPS based location information.

Abbreviations

These abbreviations and acronyms are used in this document.

AC	Advisory Circular
ADF	Automatic Direction Finder
ADS-B	Automatic Dependent Surveillance-Broadcast
ADS-R	Automatic Dependent Surveillance-Rebroadcast
AFMS	Aircraft Flight Manual Supplement
AIRMET	Airmen Meteorological Information
API	Appliance Project Identifier
CDTI	Cockpit Display of Traffic Information
ATCRBS	Air Traffic Control Radar Beacon System
CFR	Code of Federal Regulations
CG	Center of Gravity
CONUS	Continental United States
CSA	Conflict Situational Awareness
DC	Direct Current
DME	Distance Measuring Equipment
EQF	Environmental Qualification Form
ES	Extended Squitter
FAA	Federal Aviation Administration
FCC	Federal Communications Commission
FCU	Flight Control Unit
FIS-B	Flight Information Services-Broadcast
FMS	Flight Manual Supplement
GAE	Garmin Altitude Encoder
GNSS	Global Navigation Satellite System
GPS	Global Positioning System
GTX	Garmin Transponder
HSDB	High Speed Data Bus
LAT	Latitude
LON	Longitude
MCP	Mode Control Panel
METAR	Meteorological Aviation Report
MFD	Multifunction Display
MSR	Message Success Rate
NOTAM	Notice to Airmen
NEXRAD	Next Generation Radar

OAT	Outside Air Temperature
PED	Portable Electronic Device
PIREP	Pilot Weather Report
POH	Pilot Operating Handbook
RAIM	Receiver Autonomous Integrity Monitoring
RFMS	Rotorcraft Flight Manual Supplement
SATCOM	Satellite Communications
SBAS	Satellite-Based Augmentation System
SIGMET	Significant Meteorological Information
SIL	Source Integrity Level
SPI	Special Position Indicator
SUA	Special Use Airspace
TAF	Terminal Area Forecast
TAS	Traffic Advisory System
TCAS	Traffic Collision Avoidance System
TIS	Traffic Information Service
TIS-B	Traffic Information Service-Broadcast
TSO	Technical Standard Order
UAT	Universal Access Transceiver
UHF	Ultra-High Frequency
USB	Universal Serial Bus
VHF	Very High Frequency
VSWR	Voltage Standing Wave Ratio
WAAS	Wide Area Augmentation System

1.4 ADS-B Capabilities

1.4.1 ADS-B Out

The GTX 335 and GTX 345 include ADS-B Out capabilities when installed with an approved internal or external GPS position source.

1.4.2 ADS-B In

The GTX 345 includes receivers for both the UAT and the 1090 MHz frequency bands for all ADS-B In data reception capabilities. The GTX 345 receives ADS-B transmissions from other ADS-B Out equipped aircraft, ADS-R, and TIS-B information from ground stations. Traffic information received from ADS-B, ADS-R, and TIS-B transmissions supplies compatible ADS-B In data to CDTIs to show the pilot.

1.4.3 Installation Approval for ADS-B Systems

The conditions and tests necessary for TSO approval of the GTX 3X5 are minimum performance standards. It is the responsibility of the installer to determine if the aircraft installation conditions are within the TSO standards. TSO units must have separate approval to install in an aircraft. The GTX 3X5 can be installed only in compliance with 14 CFR Part 43 or the applicable airworthiness requirements.

All GTX 3X5 unit functions are design-approved under the TSO. Changes or modifications to any unit that are not approved can void the compliance to necessary regulations and authorization for continued equipment usage.

It is the installer's responsibility to make sure the ADS-B Out system installation is compliant with 14 CFR 91.227 and to make sure compatibility between the GTX 3X5 and the ADS-B Out equipment. Refer to *Garmin ADS-B Out Compatible Equipment*, for compatible equipment that is applicable for 14 CFR 91.227-compliant installations in accordance with AC 20-165A. FIS-B information is for pilot-planning and pilot near-term decisions. The information shown are areas of inclement weather that are out of visual range or are not easily seen.

1.5 FIS-B Capabilities

The GTX 345 receives FIS-B information from UAT ground stations in the United States. A direct line-of-sight between the ground station and aircraft is necessary to receive FIS-B data. The data is not available at ground level in some locations. The GTX 345 supplies the data to compatible displays. Depending on the CDTI it can show:

- NOTAM (includes TFRs)
- AIRMET
- SIGMET
- SUA
- METAR
- TAFs
- PIREP
- Winds/Temps Aloft
- Regional NEXRAD
- CONUS NEXRAD

1.6 TIS System Capabilities

The GTX 335 supplies information about nearby traffic through the FAA provided radar based TIS. Advisory traffic information is shown on a compatible Garmin display. Garmin units capable to show TIS traffic include:

- GNS 480 (CNX80)
- GTN 6XX/7XX
- GMX 200
- MX20 MFD
- GNS 400W/500W Series
- GDU 620
- GDU 1040

1.7 Interface Summary

Table 1-2 Interface Summary

Interface Description	Input/Output	GTX 335 Qty	GTX 345 Qty
RS-232	I/O	3	4
ARINC 429	O	1	1
	I	2	2
HSDB	I/O	N/A	2
RS-422	I or O	N/A	1
Discrete I/O	I [3]	15	15
	O	1	1
	I/O [1]	2	4
Gray code altitude input [3]	I [3]	1	1
Suppression bus	I/O	1	1
1PPS	O	1	1
OAT input	I	1	1
Audio output	O	1	1
Configuration module, GAE module interface [2]	I/O	1	1
USB interface	I/O	1	1
Lighting bus input	I	1	1
Switched power output	O	1	1

Notes:

- [1] Can be configured to be either input or output on a per-discrete basis.
- [2] Use for either the configuration module or combination configuration module/GAE.
- [3] The Gray code altitude input pins can be used for other functions when not used for Gray code.

1.8 General Specifications

It is the responsibility of the installer to get the latest revision of the GTX 3X5 EQF. Refer to Garmin's [Dealer Resource Center](#) to get a copy of the EQF, P/N 005-00752-02.

Table 1-3 Physical Characteristics - Panel Mount Units

Characteristic	Specification
Bezel height	1.65 in. (42 mm)
Bezel width	6.25 in. (159 mm)
Rack height (dimple to dimple)	1.68 in. (43 mm)
Rack width	6.30 in. (160 mm)
Depth behind panel with connectors (measured from face of aircraft panel to rear of connector backshells)	10.07 inches (256 mm)
GTX 335 weight (unit only)	2.0 lbs (0.91 kg)
GTX 335 with GPS weight (unit only)	2.1 lbs (0.95 kg)
GTX 345 weight (unit only)	2.3 lbs (1.04 kg)
GTX 345 with GPS weight (unit only)	2.4 lbs (1.10 kg)
GTX 335 with rack, backplate, and connectors	2.8 lbs (1.27 kg)
GTX 335 with GPS with rack, backplate, and connectors	2.9 lbs (1.32 kg)
GTX 345 with rack, backplate, and connectors	3.1 lbs (1.41 kg)
GTX 345 with GPS with rack, backplate, and connectors	3.2 lbs (1.45 kg)
Operating temperature range	-49°F to 131°F (-45°C to +70°C) Refer to the EQF for additional details.
Maximum operating altitude	55,000 feet
Humidity	95% non-condensing
Cooling	External cooling not necessary
Audio output	100 mW into 500 ohm

Table 1-4 Physical Characteristics - Remote Mount Units

Characteristic	Specification
Height, standard mount	1.7 inches (43 mm)
Width, standard mount	6.3 inches (160 mm)
Length, standard mount (unit, mount, and connector backshells)	9.9 inches (252 mm)
Height, unit and vertical remote mount	6.6 inches (167 mm)
Width, unit and vertical remote mount	1.8 inches (46 mm)
Length, unit and vertical remote mount (unit, mount, connector backshell(s))	12.7 inches (321 mm)
GTX 335R weight (unit only)	1.7 lb (0.77 kg)
GTX 335R with GPS weight (unit only)	1.8 lb (0.82 kg)
GTX 345R weight (unit only)	2.0 lb (0.91 kg)
GTX 345R with GPS (unit only)	2.2 lb (1.00 kg)
GTX 335R weight with standard mounting tray, backplate, and connectors	2.5 lb (1.13 kg)
GTX 335R with GPS weight with standard mounting tray, backplate, and connectors	2.7 lb (1.22 kg)
GTX 345R weight with standard mounting tray, backplate, and connectors	2.9 lb (1.32 kg)
GTX 345R with GPS with standard mounting tray, backplate, and connectors	3.0 lb (1.36 kg)
GTX 335R weight with vertical remote mount, backplate, and connectors	3.0 lb (1.35 kg)
GTX 335R with GPS weight with vertical remote mount, backplate, and connectors	3.1 lb (1.42 kg)
GTX 345R weight with vertical remote mount, connector backplate, and connectors	3.3 lb (1.51 kg)
GTX 345 with GPS weight with vertical remote mount, connector backplate, and connectors	3.5 lb (1.57 kg)
Operating temperature range	-49°F to 131°F (-45°C to + 70°C) For more details refer to the EQF.
Maximum operating altitude	55,000 feet
Humidity	95% non-condensing
Cooling	External cooling not necessary
Audio output	100 mW into 500 ohm

The GTX 3X5 display is a sunlight readable LCD display.

Table 1-5 Display Specifications

Characteristic	Specification
Display size	Width: 3.46 inches (87.88 mm) Height: 0.843 inches (21.4 mm)
Active area	Width: 2.95 inches (74.98 mm) Height: 0.486 inches (12.36 mm)
Resolution	200 x 33 pixels
Viewing angle	Left: 45° Right: 45° From top: 30° From bottom: 10°

1.9 Transponder Specifications

Table 1-6 Transponder Specifications

Characteristic	Specification
Transmitter frequency	1090 MHz \pm 1 MHz
Transmitter power	125 W min at antenna, with max 2dB cable loss 250 W nominal at unit
Receiver frequency	1030 MHz \pm 0.01 MHz
Receiver sensitivity	-74 dBm nominal for 90% replies
External suppression input	\geq 10 VDC to suppress
External suppression output	\geq 18 VDC with 300 ohm load, 28 VDC typical with no load

1.10 UAT Receiver Specifications (GTX 345 Only)

Table 1-7 UAT Receiver Specifications

Characteristic	Specification
Frequency	978 MHz \pm 20 ppm
Modulation	Continuous phase FSK, h = 0.6, raised cosine shaping, a = 0.5
Data rate	1.04 Mbps
Sensitivity	-96 dBm for 90% MSR

1.11 1090 MHz Receiver Specifications

Table 1-8 1090 MHz Receiver Specifications

Characteristic	Specification
Frequency	1090 MHz \pm 1 MHz
Modulation	Binary pulse-position
Data rate	1 Mbps
Sensitivity	-81 dBm for 90% MSR

1.12 GPS Specifications (Units with Internal GPS Only)

Table 1-9 GPS Receiver Specifications

Characteristic	Specification
Number of channels	15 (12 GPS and 3 GPS/SBAS)
Frequency	1575.42 MHz L1, C/A code
Sensitivity (acquisition, no interference)	-134.5 dBm GPS -135.5 dBm SBAS
Sensitivity (drop lock)	-144 dBm
Dynamic range	>20 dB
LAT/LON position accuracy	<1.25 meter RMS horizontal, <2 meter vertical, with SBAS
Velocity	1000 knots maximum (above 60,000 ft)
TTFF (Time To First Fix)	1:45 min. typical with current almanac, position, and time
Reacquisition	10 seconds typical
Position update interval	0.2 sec (5 Hz)
1PPS (Pulse Per Second)	\pm 275 nsec of UTC second
Datum	WGS-84
SATCOM compatibility	SATCOM compatibility is dependent on antenna selection
Antenna power supply	35 mA typical, 40 mA max at 4.7 VDC

1.13 Power Specifications

GTX 3X5 units require an input voltage of between 9 VDC and 33 VDC. The maximum input power and current is based upon maximum reply rates. Input power and current does not include the switched power output.

Table 1-10 Power Specifications

Unit	Characteristic	Specification	
		14 VDC	28 VDC
GTX 335	Power input	8 W typical, 15 W maximum	
	Input current, typical	0.57 A	0.29 A
	Input current, maximum	0.86 A	0.43 A
GTX 335, GPS	Power input	10 W typical, 17 W maximum	
	Input current, typical	0.72 A	0.36 A
	Input current, maximum	1.22 A	0.61 A
GTX 345	Power input	10 W typical, 18 W maximum	
	Input current, typical	0.72 A	0.36 A
	Input current, maximum	1.30 A	0.65 A
GTX 345, GPS	Power input	12 W typical, 20 W maximum	
	Input current, typical	1.07 A	0.54 A
	Input current, maximum	1.43 A	0.72 A
GTX 3X5, GPS [1]	KEEP ALIVE input current, typical	65 uA	20 uA
	KEEP ALIVE input current, maximum	85 uA	40 uA

Notes:

[1] KEEP ALIVE input only applies to units that have an internal GPS.

1.14 Certification

The GTX 3X5 meets compliance with the TSO(s) when interfaced with equipment and installed in accordance with the requirements and limitations as outlined in this manual.

FIS-B information, including weather information, NOTAMs, and TFR areas, are intended to assist in long- and near-term planning decision making. The system lacks sufficient resolution and updating capability necessary for aerial maneuvering associated with immediate decisions.

The Appliance Project Identifier (API) for the GTX 3X5 is GMN-01216. The API is used for project identification with the FAA. Refer to applicable hardware and software part numbers to identify appliance approvals.

Table 1-11 TSO Compliance

GTX 335	GTX 345	TSO	Class and Level	Function
X [2]	X [2]	TSO-C88b	--	Automatic Pressure Altitude Reporting Code-Generating Equipment
X	X	TSO-C112e	Class 1 Level 2els	Air Traffic Control Radar Beacon System / Mode Select (ATCRBS/Mode S) Airborne Equipment
X [1]	X [1]	TSO-C145d	Class B2	Airborne Navigation Sensors Using the Global Positioning System Augmented by the Satellite Based Augmentation System
	X	TSO-C154c	Class A1S	Universal Access Transceiver (UAT) Automatic Dependent Surveillance – Broadcast (ADS-B) Equipment Operating on Frequency of 978 MHz
	X	TSO-C157a	Class 1	Aircraft Flight Information Services – Broadcast (FIS-B) Data Link System and Equipment
X		TSO-C166b	Class B1S	Extended Squitter Automatic Dependent Surveillance – Broadcast (ADS-B) and Traffic Information Service – Broadcast (TIS-B) Equipment Operating on the Radio Frequency of 1090 Megahertz (MHz)
	X		Class A1S	
	X	TSO-C195a	Class C1, C2, C3, C4	Avionics Supporting Automatic Dependent Surveillance – Broadcast (ADS-B) Aircraft Surveillance Applications (ASA)

Notes:

- [1] With internal GPS.
- [2] With optional GAE module.

Table 1-12 Applicable P/Ns

Description	P/Ns
Main Software	006-B1607-0()
ADS-B Software	006-B1797-0()
GPS Software	006-B1827-0()
Main Boot Block	006-B1607-BA through -B()
ADS-B Boot Block	006-B1797-BA through -B()
GPS Boot Block	006-B1827-B()
Main CLD	006-C0153-22 through -2()
ADS-B CLD	006-C0157-21 through -2()

Table 1-13 TSO/ETSO Deviations

TSO	Deviation
TSO-C88b	1. Garmin is granted a deviation from the TSO for marking the TSO number, Type/Class and Date of Manufacture, Deviation and Software Part Number on the exterior of the unit.
	2. Garmin is granted a deviation from the TSO to use RTCA DO-160G instead of earlier versions of RTCA/DO-160 as the standard for Environmental Conditions and Test Procedures for Airborne Equipment.
TSO-C145d	1. Garmin is granted a deviation from the TSO for marking the TSO number, Type/Class and Date of Manufacture, Deviation and Software Part Number on the exterior of the unit.
	2. Garmin is granted a deviation from TSO-C145d section 7.a that requires "...provide one copy or on-line access to the data in paragraphs...5.f through 5.h of this TSO."
	3. Garmin is granted a deviation from RTCA/DO-229D Change 1 section 2.1.1.10 to use GPS antennas that meet Garmin Minimum Performance Specifications (Document No. 004-00287-00).
TSO-C154c	1. Garmin is granted a deviation from the TSO for marking the TSO number, Type/Class and Date of Manufacture, Deviation and Software Part Number on the exterior of the unit.
TSO-C157a	1. Garmin is granted a deviation from the TSO for marking the TSO number, Type/Class and Date of Manufacture, Deviation and Software Part Number on the exterior of the unit.
	2. Garmin is granted a deviation from RTCA DO-267A section 3.6.2.3 to use Product File Identifier in addition to APDU Number when reconstructing a Product File from linked APDUs as specified by Aerodrome and Airspace FIS-B Product Definitions, v4.00, dated May 2009.
TSO-C166b	1. Garmin is granted a deviation from the TSO for marking the TSO number, Type/Class and Date of Manufacture, Deviation and Software Part Number on the exterior of the unit.
	2. Garmin is granted a deviation from the TSO-C166b not to process ADS-R as required by RTCA/DO-260B section 2.2.18.
	3. Garmin is granted a deviation from RTCA/DO-260B section 2.1.10 to meet the transponder function requirements of RTCA/DO-181E instead of RTCA/DO-181D.
TSO-C195a	1. Garmin is granted a deviation from the TSO for marking the TSO number, Type/Class and Date of Manufacture, Deviation and Software Part Number on the exterior of the unit.

1.14.1 Non-TSO Functions

The following are declared non-TSO functions, these non-TSO functions as defined in this manual have been evaluated with the TSO functions. The design data for these non-TSO functions has been accepted by the FAA when these non-TSO functions are installed in accordance with the guidance and limitations provided in this manual.

The GTX 3X5 includes the following non-TSO functions.

- TIS-A (GTX 335)
- Wireless data conversion (Bluetooth interface) (GTX 345)

1.14.2 Design Assurance Levels

Table 1-14 Software Design Assurance Levels

System Function	DO-178B Level
Mode S transponder functionality	C
Display of TIS-A traffic data	C
Flight information data (FIS-B, including weather information) processing and output to display	D
Display of outside air temperature (static)	C
Flight timers	C
1090 ADS-B transmission	C
1090/UAT ADS-B reception	B
Correlation of TCAS traffic with ADS-B, ADS-R, and TIS-B traffic	B
Conflict Situational Awareness (CSA) including visual and aural alerts	B
External UAT ADS-B control	C
Internal GPS/SBAS	B
Pressure sensor module	C
Altitude monitor/alerting	C
Flight ID	C
Bluetooth output	E
HSDB packet forwarding	B
Data concentrator	C

Table 1-15 Complex Hardware Design Assurance Levels

Function	DO-254
Main board, transponder, and I/O	C
ADS-B board, 978 MHz and 1090 MHz receivers	C
GPS receiver	B [1]

Notes:

[1] Developed to DO-178B level B equivalent process.

1.14.3 Transmitter Grant of Equipment Authorization

Table 1-16 Equipment Authorization

Model	FCC ID
GTX 335	IPH-02133
GTX 335R	
GTX 345	IPH-02256
GTX 345R	

1.15 License Requirements



CAUTION

The UHF transmitter in this equipment is guaranteed to meet Federal Communications Commission acceptance over the operating temperature range. Modifications not expressly approved by Garmin could invalidate the license and make it unlawful to operate the equipment.



NOTE

For non-US installations consult the local spectrum management agency for requirements.

The Telecommunications Act of 1996, effective February 8, 1996, provides the FCC discretion to eliminate radio station license requirements for aircraft and ships. The GTX 3X5 installation must obey current transmitter licensing requirements. In the US, to find out the specific details on whether a particular installation is exempt from licensing, visit the FCC website <http://wireless.fcc.gov/aviation>.

If an aircraft license is necessary, apply for a license on FCC Form 404, *Application for Aircraft Radio Station License*. The FCC also has a fax-on-demand service to supply forms by fax. The GTX 3X5 owner accepts all responsibility for obtaining the proper licensing before using the transponder.

1.16 Reference Documents

These documents are additional sources of information to install the GTX 3X5. The technician should read all related reference materials along with this manual before unit installation. The documents in table 1-17 are found at Garmin's [Dealer Resource Center](#).

Table 1-17 Garmin Reference Documents

Document	P/N
<i>14 CFR 91.227 ADS-B Out Compatible Equipment</i>	190-01533-00
<i>Antenna Minimum Performance Specification for Garmin's GPS/WAAS Receiver System</i>	004-00287-00
<i>G1000 System Installation Manual</i>	190-00303-00
<i>GTX 3X5 Pilot's Guide</i>	190-01499-00
<i>GTX 3X5 Series Transponder G1000 Pilot's Guide</i>	190-01499-01
<i>GTX 3X5 Environmental Qualification Form</i>	005-00752-02

Table 1-18 Additional Reference Documents

Document	P/N
<i>Aerospace Systems Electrical Bonding and Grounding for Electromagnetic Compatibility and Safety</i>	SAE ARP 1870
<i>Application for Aircraft Radio Station License</i>	FCC Form 404
<i>FAA Advisory Circular, Acceptable Methods, Techniques, and Practices – Aircraft Inspection and Repair</i>	FAAAC 43.13-1B
<i>FAA Advisory Circular, Acceptable Methods, Techniques, and Practices – Aircraft Alterations</i>	FAAAC 43.13-2B

2 LIMITATIONS

The GTX 3X5 meets the minimum performance and quality control standards that are necessary by the TSOs in section 1.14. Installation of the GTX 3X5 requires separate approval.

2.1 HSDB Packet Forwarding

The GTX 345 HSDB interface is not approved for forwarding data whose failure condition for loss or malfunction is classified as hazardous or catastrophic.

2.2 ARINC 429 Data Concentrator Function

ARINC 429 data from the GTX 3X5 must not be used for any function whose associated failure is classified as hazardous or catastrophic.

3 INSTALLATION OVERVIEW

3.1	Introduction	3-2
3.2	Unit Configurations	3-2
3.3	Accessories Supplied	3-3
3.4	Optional Accessories	3-5
3.4.1	GAE	3-5
3.4.2	GX000 System Rack	3-5
3.4.3	GTX 3X5 Vertical Remote Mount	3-5
3.4.4	GPS Antenna	3-6
3.5	Necessary Installation Materials and Accessories Not Supplied	3-7
3.6	Necessary Special Tools	3-7
3.7	Transponder Antenna	3-8
3.8	GPS Antenna Requirements	3-9
3.9	Minimum Systems Configuration	3-10
3.10	GTX Input Source Priority	3-11
3.11	GPS/SBAS Parameters	3-20
3.12	Antenna Considerations	3-21
3.12.1	Transponder Antenna	3-21
3.12.2	GPS Antenna	3-22
3.13	Electrical Bonding	3-24
3.14	Cabling and Wiring	3-24
3.15	Electrical Bonding Considerations	3-24
3.16	Cooling Requirements and Considerations	3-24

3.1 Introduction

Equipment information to install the GTX 3X5 and optional accessories is in this section. Cabling is made by the installing agency to fit each particular aircraft. Always follow permitted avionics installation procedures as outlined in AC 43.13-1B and AC 43.13-2B or later FAA approved revisions.

3.2 Unit Configurations

The GTX 3X5 is available in different configurations.

Table 3-1 GTX 3X5 Configurations

Model	Mount	GPS	ADS-B In	Unit P/N	Unit Only Kit	Standard Kit	Mount Type
GTX 335	Panel			011-03300-00	010-01214-00	010-01214-01	
GTX 335 NV	Panel			011-03300-20	010-01214-20	010-01214-21	
GTX 335, GPS	Panel	X		011-03300-40	010-01214-40	010-01214-41	
GTX 335R	Remote			011-03301-00	010-01215-00	010-01215-01	Standard
GTX 335R	Remote			011-03301-00	010-01215-00	010-01215-02	Vertical
GTX 335R, GPS	Remote	X		011-03301-40	010-01215-40	010-01215-41	Standard
GTX 335R, GPS	Remote	X		011-03301-40	010-01215-40	010-01215-42	Vertical
GTX 345	Panel		X	011-03302-00	010-01216-00	010-01216-01	
GTX 345, GPS	Panel	X	X	011-03302-40	010-01216-40	010-01216-41	
GTX 345R	Remote		X	011-03303-00	010-01217-00	010-01217-01	Standard
GTX 345R	Remote		X	011-03303-00	010-01217-00	010-01217-02	Vertical
GTX 345R, GPS	Remote	X	X	011-03303-40	010-01217-40	010-01217-41	Standard
GTX 345R, GPS	Remote	X	X	011-03303-40	010-01217-40	010-01217-42	Vertical

3.3 Accessories Supplied

Table 3-2 Accessories Supplied

Unit	Kit P/N	Item	P/N
GTX 335	010-01214-01	Install rack	115-01771-00
		Backplate assembly	011-02976-00
		Connector kit	011-02977-00
		Configuration module	011-00979-03
		Product information kit	K00-00598-01
GTX 335NV	010-01214-21	Install rack	115-01771-00
		Backplate assembly	011-02976-00
		Connector kit	011-02977-00
		Configuration module	011-00979-03
		Product information kit	K00-00598-01
GTX 335 w/GPS	010-01214-41	Install rack	115-01771-00
		Backplate assembly	011-02976-01
		Connector kit	011-02977-00
		Configuration module	011-00979-03
		Product information kit	K00-00598-01
GTX 335R, standard mount	010-01215-01	Install rack	115-01771-00
		Backplate assembly	011-02976-00
		Connector kit	011-02977-00
		Configuration module	011-00979-03
		Product information kit	K00-00598-02
GTX 335R, vertical mount	010-01215-02	Install rack, vertical	011-03762-00
		Backplate assembly	010-02976-10
		Connector kit	011-02977-00
		Configuration module	011-00979-03
		Product information kit	K00-00598-02
GTX 335R w/GPS, standard mount	010-01215-41	Install rack	115-01771-00
		Backplate assembly	011-02976-01
		Connector kit	011-02977-00
		Configuration module	011-00979-03
		Product information kit	K00-00598-02

Unit	Kit P/N	Item	P/N
GTX 335R w/GPS, vertical mount	010-01215-42	Install rack, vertical	011-03762-00
		Backplate assembly	010-02976-11
		Connector kit	011-02977-00
		Configuration module	011-00979-03
		Product information kit	K00-00598-02
GTX 345	010-01216-01	Install rack	115-01771-00
		Backplate assembly	011-02976-00
		Connector kit	011-02977-01
		Configuration module	011-00979-03
		Product information kit	K00-00598-03
GTX 345 w/GPS	010-01216-41	Install rack	115-01771-00
		Backplate assembly	011-02976-01
		Connector kit	011-02977-01
		Configuration module	011-00979-03
		Product information kit	K00-00598-03
GTX 345R, standard mount	010-01217-01	Install rack	115-01771-00
		Backplate assembly	011-02976-00
		Connector kit	011-02977-01
		Configuration module	011-00979-03
		Product information kit	K00-00598-04
GTX 345R, vertical mount	010-01217-02	Install rack, vertical	011-03762-00
		Backplate assembly	010-02976-10
		Connector kit	011-02977-01
		Configuration module	011-00979-03
		Product information kit	K00-00598-04
GTX 345R w/GPS, standard mount	010-01217-41	Install rack	115-01771-00
		Backplate assembly	011-02976-01
		Connector kit	011-02977-01
		Configuration module	011-00979-03
		Product information kit	K00-00598-04

Unit	Kit P/N	Item	P/N
GTX 335R w/GPS, vertical mount	010-01217-42	Install rack, vertical	011-03762-00
		Backplate assembly	010-02976-11
		Connector kit	011-02977-01
		Configuration module	011-00979-03
		Product information kit	K00-00598-04

3.4 Optional Accessories

3.4.1 GAE

The GTX 3X5 uses an optional GAE module to use as a transponder pressure altitude input. The GAE module directly attaches to the GTX 3X5 rear backplate and connects to the aircraft static pressure system. The GAE module replaces and functions the same as the configuration module.

Table 3-3 Pressure Sensor Module

Item	P/N
Pressure sensor module	011-03080-00

3.4.2 GX000 System Rack

The GTX 3X5 has an optional mount and hardware for GX000 installations.

Table 3-4 GX000 System Rack

Item	P/N
GTX 3X5 Remote Rack, G1000	115-02250-00
G1000 nut plate kit, 3 position	011-00915-01

3.4.3 GTX 3X5 Vertical Remote Mount

The GTX 3X5 vertical remote mount is available as separate components. The base kit mounts to the aircraft. The shoe kit mounts to the GTX 3X5.

Table 3-5 GTX 3X5 Vertical Remote Mount Kits

Item	P/N
GTX 3X5 Vertical Remote Mount, Base Kit	011-03762-10
GTX 3X5, Vertical Remote Mount, Shoe Kit	011-03762-20

3.4.4 GPS Antenna

A GPS antenna is necessary for the GTX 335 and GTX 345 with the internal GPS option. Refer to section 3.8 for information about antenna selection and part numbers.

GA 35 Antenna

The antenna includes four 8-32 UNC-2A x 1.00" SS 303 mounting screws and one O-ring.

It can be necessary to use an antenna doubler. Refer to applicable antenna installation data.

Use four #8 washers and four #8 self-locking to attach the antenna. Applicable nut plates can be attached to the doubler. Torque the four supplied 8-32 stainless steel screws 12-15 in-lbs. Apply torque equally across all mounting screws to avoid deformation of the mounting area. Use a TNC plug to connect the GPS antenna coax cable.

GA 36 Antenna

The antenna includes four 10-32 UNF-2A x 1.00" SS 303 mounting screws and one O-ring.

It can be necessary to use an antenna doubler. Refer to applicable antenna installation data.

Attach the antenna with four #10 washers and four #10 self-locking nuts. Applicable nut plates can be attached to the doubler. Torque the four supplied 10-32 stainless steel screws 20-25 in-lbs. Apply torque equally across all mounting screws to avoid deformation of the mounting area.

Use a TNC plug to connect the GPS antenna coax cable.

GA 37 Antenna

The antenna includes four 10-32 UNF-2A x 1.00" SS 303 mounting screws and one O-ring.

It can be necessary to use an antenna doubler. Refer to applicable antenna installation data.

Attach the antenna with four #10 washers and four #10 self-locking nuts.. Applicable nut plates can be attached to the doubler. Torque the four supplied 10-32 stainless steel screws 20-25 in-lbs. Apply torque equally across all mounting screws to avoid deformation of the mounting area.

Use a TNC plug to connect the GPS antenna coax cable.

A33W Antenna

The antenna includes four 6-32 UNC-2A x 1.00" SS 303 mounting screws and one O-ring.

It can be necessary to use an antenna doubler. Refer to applicable antenna installation data.

Attach the antenna with four #6 washers and four self-locking nuts. Applicable nut plates can be attached to the doubler. Torque the four supplied 6-32 stainless steel screws 3-5 in-lbs. Apply torque equally across all mounting screws to avoid deformation of the mounting area.

Use a TNC plug to connect the GPS antenna coax cable.

3.5 Necessary Installation Materials and Accessories Not Supplied

The GTX 3X5 is installed with standard aviation materials. The following items are necessary for installation, but not supplied.

- Wire (MIL-W-22759/16 or equivalent)
- Shielded wire (MIL-C-27500 or equivalent)
- Aircraft grade category 5 Ethernet cable is necessary for installations utilizing the HSDB interfaces
- Mounting hardware
- Circuit breaker of applicable rating
- Tie wraps and/or lacing cord
- Ring terminals for grounding
- Coaxial cable (RG-400 or equivalent)
- Coax connectors – BNC connectors for the transponder antenna and TNC connectors for the GPS antenna
- Approved pressure altitude source

3.6 Necessary Special Tools



NOTE

Insertion/extraction tools from ITT Cannon are all plastic. The others are plastic with metal tips.

Some connectors use crimp contacts. Use crimp tools in table 3-6 to make sure reliable crimp contact connections for the rear D-sub connectors are correct.

Table 3-6 Recommended Crimp Tools

Manufacturer	Hand Crimping Tool	22-28 AWG (P3251, P3252)	
		Positioner	Insertion/Extraction Tool
Military PN	M22520/2-01	M22520/2-09	M81969/14-01 M81969/1-04
Positronic	9507-0-0-0	9502-4-0-0	M81969/1-04
ITT Cannon	995-0001-584	995-0001-739	000849490 274-7048-000MIL
AMP	601966-1	601966-6	91067-1 2031838-1
Daniels	AFM8	K42	M81969/14-01 M81969/1-04
Astro	615717	615725	M81969/14-01 M81969/1-04

3.7 Transponder Antenna



NOTE

For the GTX 345 some types of transponder antennas that utilize thin radiator elements are only intended for use at 1030 and 1090 MHz. These types of antennas should be evaluated on a model-by-model basis to determine their suitability for UAT receivers.

The GTX 3X5/3X5R must have an UHF antenna. The antennas in table 3-7 are approved for use with the GTX 3X5/3X5R. Other antennas are permitted if they meet these specifications:

- Standard 50 ohm vertically polarized antenna with a VSWR $\leq 1.7:1$ at 978 MHz and $\leq 1.5:1$ at 1090 MHz
- TSO-C66(), TSO-C74(), or TSO-C112() antennas that also meet the VSWR specification

Table 3-7 Acceptable UAT/1090 Antennas

Manufacturer	P/N	Model/Description	Connector Type	Notes
Aero Antenna	AT130-16	DME Transponder	TNC	DC Grounded
Comant	CI-100	DME Transponder	BNC	Open Circuit
	CI-100-2	DME Transponder	TNC	Open Circuit
	CI-105	DME Transponder	BNC	Open Circuit
	CI-105-3	DME Transponder	BNC	Open Circuit
	CI-105-16	DME Transponder	BNC	Open Circuit
	CI-110-40-30	DME Transponder	C	Open Circuit
	CI-110-41-30	DME Transponder	C	DC Grounded
	CI-110-60-30	DME Transponder	C	Open Circuit
	CI-110-61-30	DME Transponder	C	DC Grounded
Dayton-Granger	L10-611-()	L-Band Blade	C	DC Grounded
Garmin	590-0052 or 013-00219-00	A-40	TNC	Open Circuit
	590-0051 or 013-00174-00	A-41	TNC	DC Grounded

3.8 GPS Antenna Requirements

Use an antenna in table 3-8 to get the best performance with the GTX 3X5 with internal GNSS receiver. These antennas meet specifications in the document *Antenna Minimum Performance Specification for Garmin's GPS/WAAS Receiver System*.

Table 3-8 GNSS Receiver Antennas

Model/Description	Connector Type	Manufacturer	P/N	Garmin Order Number
GA 35, GPS/WAAS [1]	TNC	Garmin	013-00235-()	013-00235-()
		Aero Antenna	AT575-93G()-TNCF-000-RG-27-NM	N/A
GA 36, GPS/WAAS	TNC	Garmin	013-00244-()	013-00244-()
		Aero Antenna	AT575-126G()-TNCF-000-RG-27-NM	N/A
GA 37, GPS/WAAS/XM	TNC	Garmin	013-00245-()	013-00245-()
		Aero Antenna	AT2300-126G()-TNCF-000-RG-27-NM	N/A
A33W, WAAS Antenna	TNC	Garmin	013-00261-()	013-00261-()
		Aero Antenna	AT575-332G()-TNCF-000-RG-27-NM	N/A
GPS/VHF Antenna [2]	TNC/BNC	Comant	CI-2580-200	N/A
GPS/VHF Antenna [2]	TNC/BNC	Comant	CI-2728-200	N/A
GPS/XM/VHF Antenna [3]	TNC/TNC/BNC	Comant	CI-2580-410	N/A
GPS/XM/VHF Antenna [3]	TNC/TNC/BNC	Comant	CI-2728-410	N/A
GPS/WAAS Antenna	TNC	Comant	CI-428-200	N/A
GPS/XM Antenna	TNC/TNC	Comant	CI-428-410	N/A

- [1] Same mounting hole pattern as GA 56, except GA 35 has a physically larger footprint.
- [2] The GPS antenna connector is a TNC and the VHF connector is BNC.
- [3] The GPS antenna connector is a TNC connector, the XM connector is TNC, and the VHF connector is BNC.

3.9 Minimum Systems Configuration

Refer to table 3-10 for compatible ADS-B traffic/FIS-B displays. GTN 6XX/7XX, GNS 480 (CNX80), and Legacy G1000 displays are compatible control panels. When installing a model in table 3-9, each item marked with an X on the same row is necessary.

Table 3-9 Minimum System Configuration

Model	Transponder Antenna	Altitude Source	External GPS/SBAS Position Source	GPS/SBAS Antenna	Control Panel	ADS-B Traffic/FIS-B Display or Traffic Light	Audio Panel
GTX 335	X	X	X				
GTX 335R	X	X	X		X		
GTX 335 w/GPS	X	X		X			
GTX 335R w/GPS	X	X		X	X		
GTX 345	X	X	X			X	X
GTX 345R	X	X	X		X	X	X
GTX 345 w/GPS	X	X		X		X	X
GTX 345R w/GPS	X	X		X	X	X	X

Table 3-10 Compatible ADS-B Traffic/FIS-B Displays

Display	FIS-B Source Format	ADS-B Traffic Source Format
GTN 6XX/7XX	HSDB	HSDB
GDU 620	HSDB	HSDB
GNS 400W/500W Series	RS-232: GNS	ARINC 429: Traffic
Legacy G1000	RS-422: MX Format 1	RS-232: Legacy Traffic

3.10 GTX Input Source Priority

The GTX 3X5 accepts data from multiple sources. If multiple sources supply data to the unit, only valid data from the highest priority source is used. Source priorities are shown from highest to the lowest.

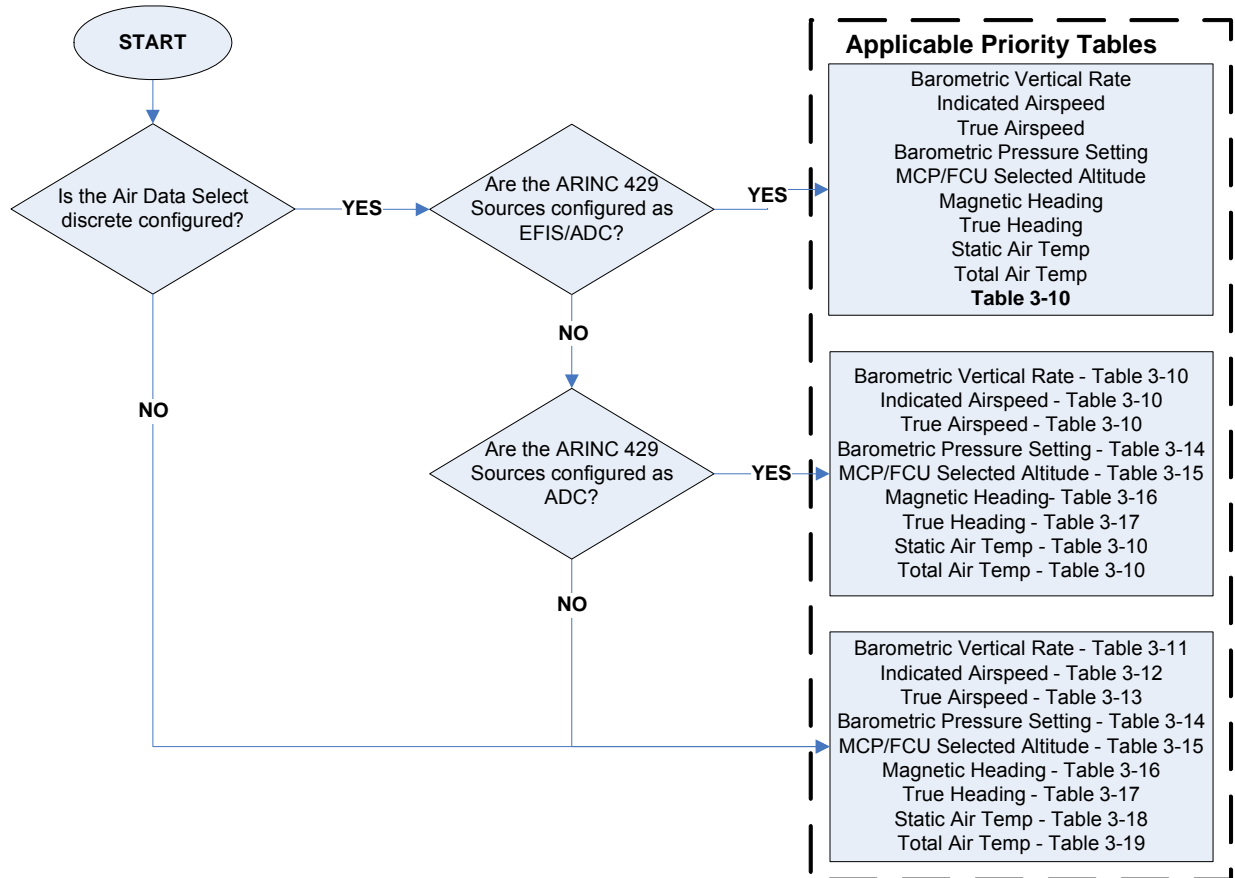

Figure 3-1 Air Data Discrete Priority Order

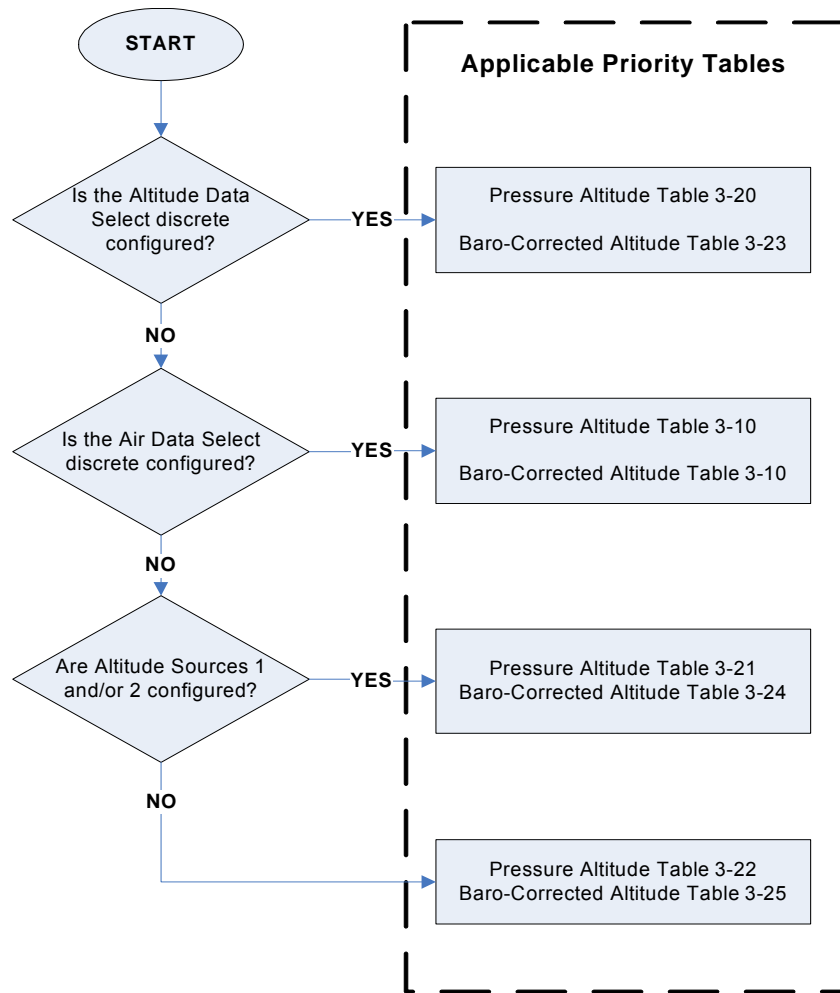

Figure 3-2 Pressure Altitude Priority Order

Table 3-11 Air Data Select Source Priority

Air Data Select Discrete	Source
Open	Configured Port 1 ARINC 429 EFIS ADC/ADC input
Ground	Configured Port 2 ARINC 429 EFIS ADC/ADC input

Table 3-12 Barometric Vertical Rate Source Priority

Priority	Source
1	ARINC 429 Label 212 from an ADC
2	ARINC 429 Label 212 from an EFIS/ADC
3	RS-232 from an ADC
4	RS-232 from a remote control panel
5	HSDB Barometric Vertical Rate from a GX000
6	HSDB Barometric Vertical Rate from GDU 620 #1
7	HSDB Barometric Vertical Rate from GDU 620 #2

Table 3-13 Indicated Airspeed Source Priority

Priority	Source
1	ARINC 429 Label 206 from an ADC
2	ARINC 429 Label 206 from an EFIS/ADC
3	RS-232 from an ADC
4	RS-232 from a remote control panel
5	HSDB Indicated Airspeed from a GX000
6	HSDB Indicated Airspeed from GDU 620 #1
7	HSDB Indicated Airspeed from GDU 620 #2

Table 3-14 True Airspeed Source Priority

Priority	Source
1	ARINC 429 Label 210 from an ADC
2	ARINC 429 Label 210 from an EFIS/ADC
3	RS-232 from an ADC
4	RS-232 from a remote control panel
5	HSDB True Airspeed from a GX000
6	HSDB True Airspeed from GDU 620 #1
7	HSDB True Airspeed from GDU 620 #2

Table 3-15 Barometric Pressure Setting Source Priority



NOTE

If the Air Data Select discrete input is configured and the source is EFIS/Air Data, Label 235 will have priority over Label 234.

Priority	Source
1	ARINC 429 Label 235 from an EFIS/ADC
2	ARINC 429 Label 234 from an EFIS/ADC
3	ARINC 429 Label 235 from an AFCS
4	ARINC 429 Label 234 from an AFCS
5	RS-232 from an ADC
6	RS-232 from a remote control panel
7	HSDB Barometric Pressure Setting from a GX000
8	HSDB Barometric Pressure Setting from GDU 620 #1
9	HSDB Barometric Pressure Setting from GDU 620 #2

Table 3-16 MCP/FCU Selected Altitude Source Priority

Priority	Source
1	ARINC 429 Label 102 from an AFCS
2	ARINC 429 Label 102 from an EFIS/ADC
3	RS-232 from a remote control panel
4	HSDB Selected Altitude from a GX000
5	HSDB Selected Altitude from GDU 620 #1
6	HSDB Selected Altitude from GDU 620 #2

Table 3-17 Magnetic Heading Source Priority

Priority	Source
1	ARINC 429 Label 320 from a heading source
2	ARINC 429 Label 320 from an AHRS
3	ARINC 429 Label 320 from an EFIS/ADC
4	RS-232 from an ADC
5	RS-232 from a remote control panel
6	HSDB Magnetic Heading from GTN #1
7	HSDB Magnetic Heading from GTN #2
8	HSDB Magnetic Heading from a GX000
9	HSDB Magnetic Heading from GDU 620 #1
10	HSDB Magnetic Heading from GDU 620 #2

Table 3-18 True Heading Source Priority

Priority	Source
1	ARINC 429 Label 314 from a heading source
2	ARINC 429 Label 314 from an AHRS
3	ARINC 429 Label 314 from an EFIS/ADC
4	RS-232 from a remote control panel
5	HSDB True Heading from a GX000

Table 3-19 Static Air Temperature Source Priority

Priority	Source
1	ARINC 429 Label 213 from an ADC
2	ARINC 429 Label 213 from an EFIS/ADC
3	RS-232 from an ADC
4	RS-232 from a remote control panel
5	HSDB Static Air Temperature from a GX000
6	HSDB Static Air Temperature from GDU 620 #1
7	HSDB Static Air Temperature from GDU 620 #2

Table 3-20 Total Air Temperature Source Priority

Priority	Source
1	ARINC 429 Label 211 from an ADC
2	ARINC 429 Label 211 from an EFIS/ADC
3	RS-232 from an ADC
4	RS-232 from a remote control panel
5	HSDB Total Air Temperature from a GX000
6	HSDB Total Air Temperature from GDU 620 #1
7	HSDB Total Air Temperature from GDU 620 #2
8	Outside air temperature sensor if OAT Sensor Installed is active

Table 3-21 Pressure Altitude Source Selection #1

Altitude Data Select Discrete	Source
Open	RS-232 from a remote control panel
Ground	Source specified in Altitude Source Configuration 2

Table 3-22 Pressure Altitude Source Priority Order #1

Priority	Source
1	Source specified in Altitude Source Configuration 1
2	Source specified in Altitude Source Configuration 2

Table 3-23 Pressure Altitude Source Priority Order #1

Priority	Source
1	ARINC 429 Label 203 from an ADC
2	ARINC 429 Label 203 from an EFIS/ADC
3	RS-232 from an ADC
4	RS-232 from a 25 ft resolution altitude source
5	RS-232 from a remote control panel
6	Optional GAE module
7	HSDB Pressure Altitude from GTN #1
8	HSDB Pressure Altitude from GTN #2
9	HSDB Pressure Altitude from a GX000
10	HSDB Pressure Altitude from GDU 620 #1
11	HSDB Pressure Altitude from GDU 620 #2
12	Gray code altitude
13	RS-232 from a 100 ft resolution altitude source

Table 3-24 Baro-Corrected Altitude Source Selection #1

Altitude Data Select Discrete	Source
Open	Source specified in Altitude Source Configuration 1
Ground	Source specified in Altitude Source Configuration 2

Table 3-25 Baro-Corrected Altitude Source Priority Order #1

Priority	Source
1	Source specified in Altitude Source Configuration 1
2	Source specified in Altitude Source Configuration 2

Table 3-26 Baro-Corrected Altitude Source Priority Order #2

Priority	Source
1	ARINC 429 Label 204 from an ADC
2	ARINC 429 Label 204 from an EFIS/ADC
3	RS-232 from an ADC

Table 3-27 AHRS Source Priority

Priority	Source
1	ARINC 429 labels 270, 324, 325, 332, 333, and 340 from an AHRS.
2	RS-232 from a remote control panel
3	HSDB AHRS Data from a GX000
4	HSDB AHRS Data from GDU 620 #1
5	HSDB AHRS Data from GDU 620 #2
6	AHRS Data from the Internal AHRS

Table 3-28 Airport Reference Points Source Priority

Priority	Source
1	RS-232 from a remote control panel
2	HSDB Runway Information from GTN #1
3	HSDB Runway Information from GTN #2
4	HSDB Runway Information from a GX000
5	HSDB Runway Information from GDU 620 #1
6	HSDB Runway Information from GDU 620 #2

Table 3-29 Density Altitude Source Priority

Priority	Source
1	RS-232 from an ADC
2	RS-232 from a remote control panel
3	HSDB Density Altitude from a GX000
4	HSDB Density Altitude from GDU 620 #1
5	HSDB Density Altitude from GDU 620 #2

Table 3-30 Height Above Terrain Source Priority

Priority	Source
1	RS-232 from a remote control panel
2	RS-232 from a GNS
3	HSDB Height Above Terrain from GTN #1
4	HSDB Height Above Terrain from GTN #2
5	HSDB Height Above Terrain from a GX000
6	HSDB Height Above Terrain from GDU 620 #1
7	HSDB Height Above Terrain from GDU 620 #2

Table 3-31 Radio Altitude Source Priority

Priority	Source
1	ARINC 429 Label 164 from a radar altimeter
2	ARINC 429 Label 164 from an EFIS/ADC
3	RS-232 from a remote control panel
4	HSDB Radio Height from GTN #1
5	HSDB Radio Height from GTN #2
6	HSDB Radio Height from a GX000
7	HSDB Radio Height from GDU 620 #1
8	HSDB Radio Height from GDU 620 #2

Table 3-32 Selected Course and Joystick Waypoint Source Priority

Priority	Source
1	ARINC 429 Labels 100, 306, and 307 from an EFIS/ADC

Table 3-33 FMS Selected Altitude Priority

Priority	Source
1	RS-232 from a remote control panel
2	HSDB FMS Vertical Navigation Data from a GX000
3	HSDB FMS Vertical Navigation Data from GDU 620 #1
4	HSDB FMS Vertical Navigation Data from GDU 620 #2

Table 3-34 Magnetic Variation Source Priority

Priority	Source
1	HSDB Magnetic Variation from a GX000
2	HSDB Magnetic Variation from GDU 620 #1
3	HSDB Magnetic Variation from GTN #1
4	HSDB Magnetic Variation from GTN #2
5	HSDB Magnetic Variation from GDU 620 #2
6	RS-232 from a GNS

3.11 GPS/SBAS Parameters

The GTX 3X5 receives from internal and external GPS receivers:

- Latitude
- Longitude
- Height above ellipsoid
- Horizontal and vertical position accuracy data
- Horizontal position integrity data
- North/south velocity
- East/west velocity
- Up/down velocity
- Ground speed
- Horizontal velocity accuracy
- Ground track
- Geometric vertical rate
- SIL and SIL supplement
- RAIM alarm
- Geoid altitude
- Time
- Date

3.12 Antenna Considerations

Mounting location considerations for the antenna(s) are provided in this section. The recommended antenna locations are shown in figure 3-3.

3.12.1 Transponder Antenna



NOTE

Ground planes must be considered for installations on composite aircraft. Conductive wire mesh, radials, or thin aluminum sheets embedded in the composite material supply the ground plane to maximize the antenna pattern (gain). This can improve transponder performance.

The antenna mounting must use the aircraft manufacturer's type certificated antenna location and style. The antenna must be installed in accordance with manufacturer instructions and/or AC 43.12-2A Chapter 3.

Transponder antenna considerations help the installer to select the best location for the antenna. The antenna should:

- Be attached away from major protrusions, such as engines, nacelles, propellers, and antenna masts.
- Be as far as practical from landing gear doors, access doors, or other openings that could affect its radiation pattern.
- Be vertically attached on the bottom of the aircraft.
- Not be attached within three feet of the ADF sense antenna or any other communication antenna.
- Not be attached within six feet of a DME antenna.
- Be attached a minimum of three feet from the GTX 3X5 to prevent RF interference.

3.12.2 GPS Antenna



NOTE

When attaching a combination antenna, the recommended distance of two feet or more is not applicable to the distance between the antenna elements of the combination antenna (ex. GPS and COM, GPS and XM) provided the combination antenna is TSO authorized and has been tested to meet Garmin's minimum performance standards. Refer to table 1-10 for approved antennas.



NOTE

If twelve inch spacing is not practical, the maximum center-to-center spacing must be used, but never less than nine inches. Spacing less than nine inches results in unacceptable antenna pattern degradation.

The installation guidelines meet the intent of AC 20-138A section 16. The greater the deviation from these guidelines, the greater the chance of decreased signal quality and availability. It is possible that all of the installation guidelines cannot be met. These guidelines are listed in order of importance to get the best performance. The installer should use best judgment to balance the installation guidelines.

The GPS antenna should:

- Be installed as near to level as possible with respect to the normal cruise flight attitude of the aircraft.
- Be installed in a location to minimize the effects of airframe shadowing during typical maneuvers.
- Be installed a minimum of two feet from any VHF COM antenna or any other antenna which may emit harmonic interference at the L1 frequency of 1575.42 MHz.
- Be installed a minimum of two feet from any antennas emitting more than 25 watts.
- Be installed a minimum of nine inches (center to center) from other antennas, including passive antennas such as another GPS or XM antenna.
- Be installed a minimum of three inches from the windscreen.
- Have a twelve inch center to center spacing between GPS antennas.

An aircraft EMC check can find the source of GPS degradation in the presence of interference signals. If an EMC check shows unacceptable interference, either insert a GPS notch filter in line with the offending VHF COM or the (re-radiating) ELT transmitter, or select a different GPS antenna location.

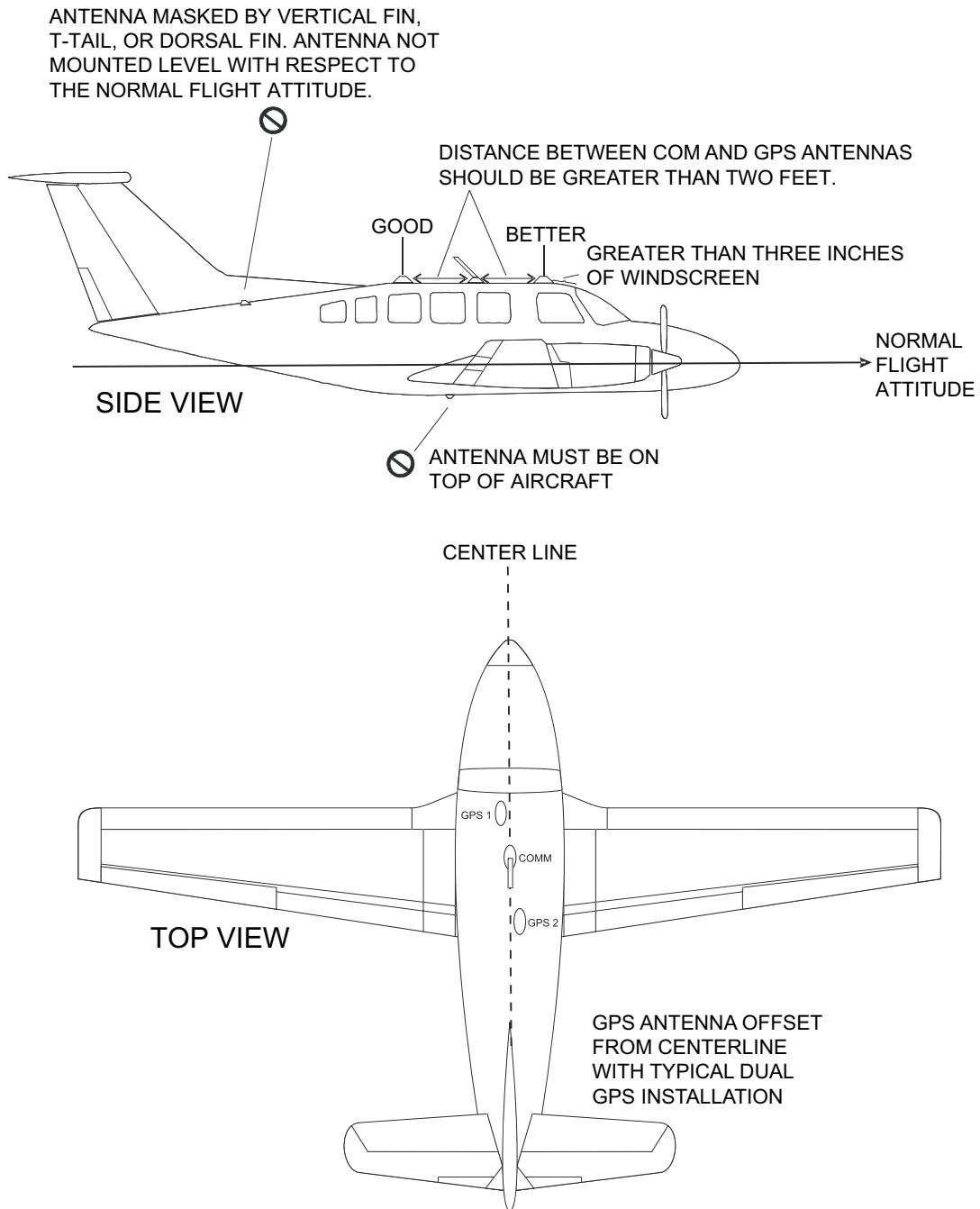

Figure 3-3 GPS Locations of Antennas

3.13 Electrical Bonding

Make sure the transponder and GPS antennas are electrically bonded to the aircraft.

3.14 Cabling and Wiring

Use AC 43.13-1B chapter 11, sections 8 through 13 to install wiring. The considerations are as follows:

- It should not be possible for the cable harness to be exposed to wire chafing.
- The cable harness should not be located near flight control cables, high capacity electrical lines (e.g., DC electric motor cables), or fuel lines.
- Do not put cables near high energy sources (e.g., DC motors, high heat sources).
- Wiring that must be shielded must be done as shown in appendix D.
- Shield pigtail lengths must be less than 3.0 inches.

3.15 Electrical Bonding Considerations

Bond electrical equipment, supporting brackets, and racks to the aircraft's main structure. Refer to SAE ARP 1870 section 5 when surface preparation is necessary to get an electrical bond. Use a calibrated milliohm meter to measure the resistance of the bond between the equipment and the adjacent aircraft structure. The bond must have a DC resistance no more than 2.5 milliohms.

3.16 Cooling Requirements and Considerations

There are no cooling requirements or considerations for the GTX 3X5. The chassis has provisions for a fan, however one is not necessary or provided.

4 INSTALLATION PROCEDURE

4.1	Wire Harness Installation	4-1
4.2	Backshell Assembly Parts	4-2
4.3	Shielded Cable Preparation	4-3
4.4	Connector and Backshell Assembly	4-5
4.5	Configuration Module Installation	4-8
4.6	Coax Cable Installation	4-10
4.7	Equipment Rack Installation	4-11
4.7.1	Panel Mount Units	4-11
4.7.2	Standard Remote Mount Units	4-11
4.7.3	Vertical Remote Mount Units	4-12
4.7.4	GX000 Integrated Flight Decks	4-12
4.8	Panel and Standard Remote Mount Unit Installation and Removal	4-12
4.9	Vertical Remote Mount Unit Installation and Removal	4-13

4.1 Wire Harness Installation

All electrical connections, except for the antenna(s) and shield grounds, are made through the D-sub connectors on the rear of the unit. The shield grounds terminate to the connector backshells.

For additional information:

- Refer to section 5 for rear connector pinout and descriptions of interface connections
- Refer to appendix D for interconnect diagrams
- Refer to section 3.12 for special tools

Give sufficient space for installation of cables and connectors. The installer supplies and assembles all cables. Cable lengths are dependent upon the installation.

To install pins into connectors and build a wire harness:

1. Remove 0.17 inches of insulation from wires going to the connectors.
2. Put the wire into the pin and crimp with one of the recommended (or equivalent) crimping tools.
3. Put the pin into the connector housing location as specified by the interconnect drawings in appendix D.
4. Gently pull on the wire to make sure the pin is properly engaged into the connector.
5. Route and attach the cable run from the GTX 3X5 to the other units. Refer to section 3.14.

4.2 Backshell Assembly Parts

The GTX 3X5 connector kits include backshell assemblies and ground adapter assemblies. Use the shield block ground kit to terminate shield grounds to the backshell housing. Garmin part numbers for the D-sub connectors and the backshell assemblies are in table 4-1.

Table 4-1 Backshell Assembly

Refer to Figure 4-2 through Figure	Description	Garmin P/N	Notes
1	Backshell (P3251) Backshell (P3252)	125-00084-00 125-00081-00	[1]
2	Shield block (P3251) Shield block (P3252)	117-00147-01 117-00147-00	[2]
3	Screw, 4-40 x.250, FLHP100°, SS/P, nylon	211-63234-08	[2]
6	Screw, 4-40x.375, PHP, SS/P, with nylon	211-60234-10	[1]
7	Strain relief (P3251) Strain relief (P3252)	115-00499-03 115-00499-00	[1]
8	Cover (P3251) Cover (P3252)	115-00500-03 115-00500-00	[1]
9	Screw, 4-40x.187, FLHP100, SS/P, with nylon	211-63234-06	[1]
10	Connector, D-sub, HD, 62-pin (P3251) Connector, D-sub, HD, 15-pin (P3252)	330-00185-62 330-00185-15	[3]
11	Multiple conductor shielded cable	As necessary	[4]
12	Shield terminator	As necessary	[4] [5]
13	Wire, insulated, 20-22 AWG (3 inches maximum length)	As necessary	[4] [5]
14	Pin contacts, #22D	336-00021-00	[3]
15	Ring terminal, #8, insulated, 18-22 AWG, 14-16 AWG	MS25036-149, MS25036-153, MS25036-156	[4] [6]
16	Screw, PHP, 8-32 x .312", stainless or cad plated steel	MS51957-42, MS35206-242	[4] [6]
17	Split washer, #8, (.045" compressed thickness) stainless or cad-plated steel	MS35338-137, MS35338-42	[4] [6]
18	Flat washer, #8, .032" thick, .174" ID, .375" OD, stainless or cad plated steel	NAS1149CN832R, NAS1149FN832P	[4] [6]
19	Silicone fusion tape	249-00114-00	[4]

Notes:

- [1] Supplied as part of backshell kits, P/N 011-00950-03 (P3251), and P/N 011-00950-00 (P3252). These are included in the connector kits, P/N 011-02977-().
- [2] Supplied as part of ground adapter kits P/N 011-01169-01 (P3251) and P/N 011-01169-00 (P3252). These are included in the connector kits, P/N 011-02977-().
- [3] Supplied as part of GTX connector kit P/N 011-02977-00 (GTX 335), and P/N 011-02977-01 (GTX 345).
- [4] Not supplied – must be purchased separately.
- [5] Solder sleeve with pre-installed shield drain wire may be used instead of items 12 and 13.
- [6] Not a Garmin part number.

4.3 Shielded Cable Preparation



NOTE

Solder sleeves with pre-installed shield drains can be used instead of separate shield terminators (12) and individual wires (13). A preferred solder sleeve is M83519/2-X series with a pre-installed shield drain.

Prepare all of the shielded cables using one of the methods shown in figure 4-1. Refer to figure 4-2 for details of the shield termination to the connector backshell.

1. At the end of the shielded cable (11), strip back a 2.5" maximum length of the jacket to expose the braid.
2. Remove the exposed braid.
3. Carefully score the jacket 1/4" to 5/16" from the end and remove the jacket to leave the braid exposed.
4. Connect a 20 or 22 AWG wire (13) to the exposed shield of the prepared cable assembly. Refer to figure 4-1. AC 43.13 maybe a helpful reference for termination techniques.
5. Slide a shield terminator (12) onto the prepared cable assembly (11) and connect the shield wire (13) to the shield using a heat gun approved for use with solder sleeves.
6. Crimp contacts (14) onto the cable wires. Refer to section 4.1.
7. Repeat steps 1 through 6 as necessary for the remaining shielded cables.
8. Install a ring terminal (15) onto the cable shield termination wires (13).
9. Group wires as applicable for the connector. Refer to section 4.4.

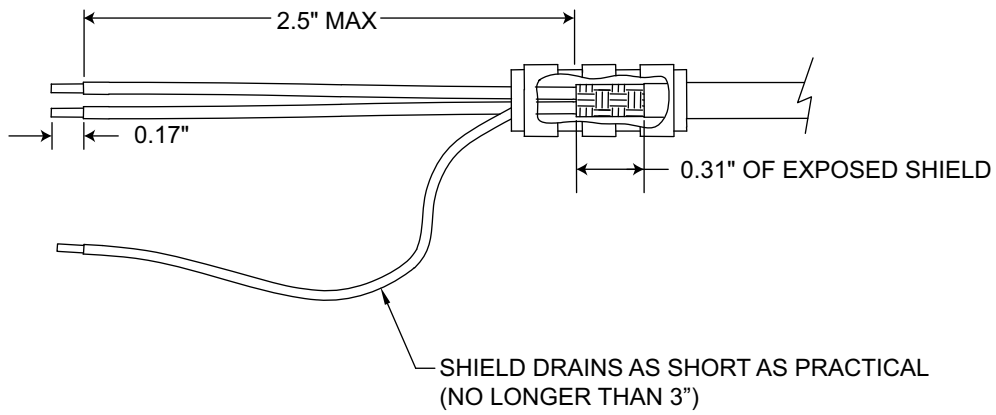

Preferred Method

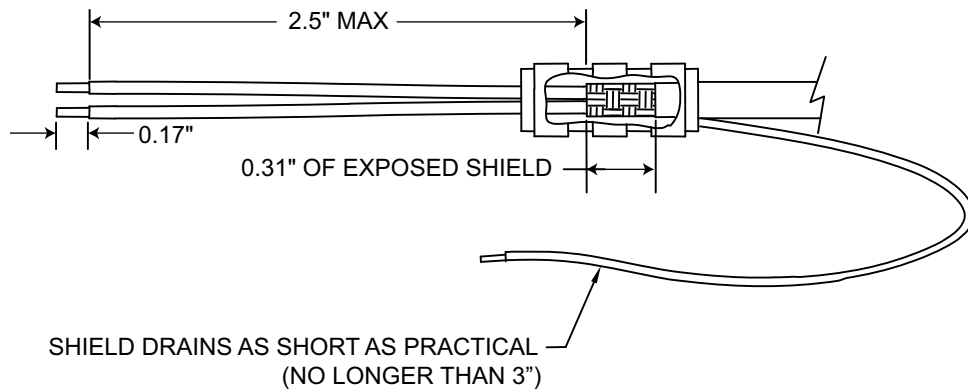

Alternate Method

Figure 4-1 Shielded Cable Preparation

4.4 Connector and Backshell Assembly



CAUTION

Do not place the concave side of the strain relief clamp (9) across the cable bundle. The cable bundle can be damaged.



NOTE

The configuration module and GAE use the same connector pin locations and cannot be used at the same time.



NOTE

Each tapped hole on the backshell (1) will only take two ring terminals (15). It is recommended to terminate a maximum of two wires (13) per ring terminal. This necessitates the use of a ring terminal, #8, insulated, 14-16 AWG (MS25036-153). If only a single wire is left or if only a single wire is necessary for this connector, a ring terminal, #8, insulated, 18-22 AWG (MS25036-149) can be used. If more wires exist for the connector than two per ring terminal, it is permitted to terminate three wires per ring terminal.

Refer to figure 4-2 and figure 4-3 for this procedure.

1. Insert flathead screws (3) through holes on the shield block (2).
2. Attach to the backshell (1).
3. Insert the crimped wire harness contacts (14) in the D-sub connector (10). Refer to appendix D for the chosen contact location.
4. Install the configuration module or GAE wires into the connector if a configuration module or GAE is used. Refer to section 4.5.
5. Group wires as applicable for the connector.
6. Wrap the cable bundle with silicone fusion tape (19) so the backshell strain relief and cast housing touches the cable bundle.
7. Place the backshell around the connector and wire harness so it rests against the front of the backshell.
8. Place the smooth side of the backshell strain relief clamp (7) across the cable bundle.
9. Attach with three 4-40 x 0.375" pan head screws (6).
10. Attach configuration module. Refer to section 4.5 and figure 4-4.
11. Attach the cover (8) to the backshell using two screws (9).
12. On the pan head screw(16) place in order:
 - Split washer (17)
 - Flat washer (18)
 - First ring terminal (15)
 - If necessary, second ring terminal
13. Insert the assembled pan head screw (16) into the tapped holes on the shield block (2).

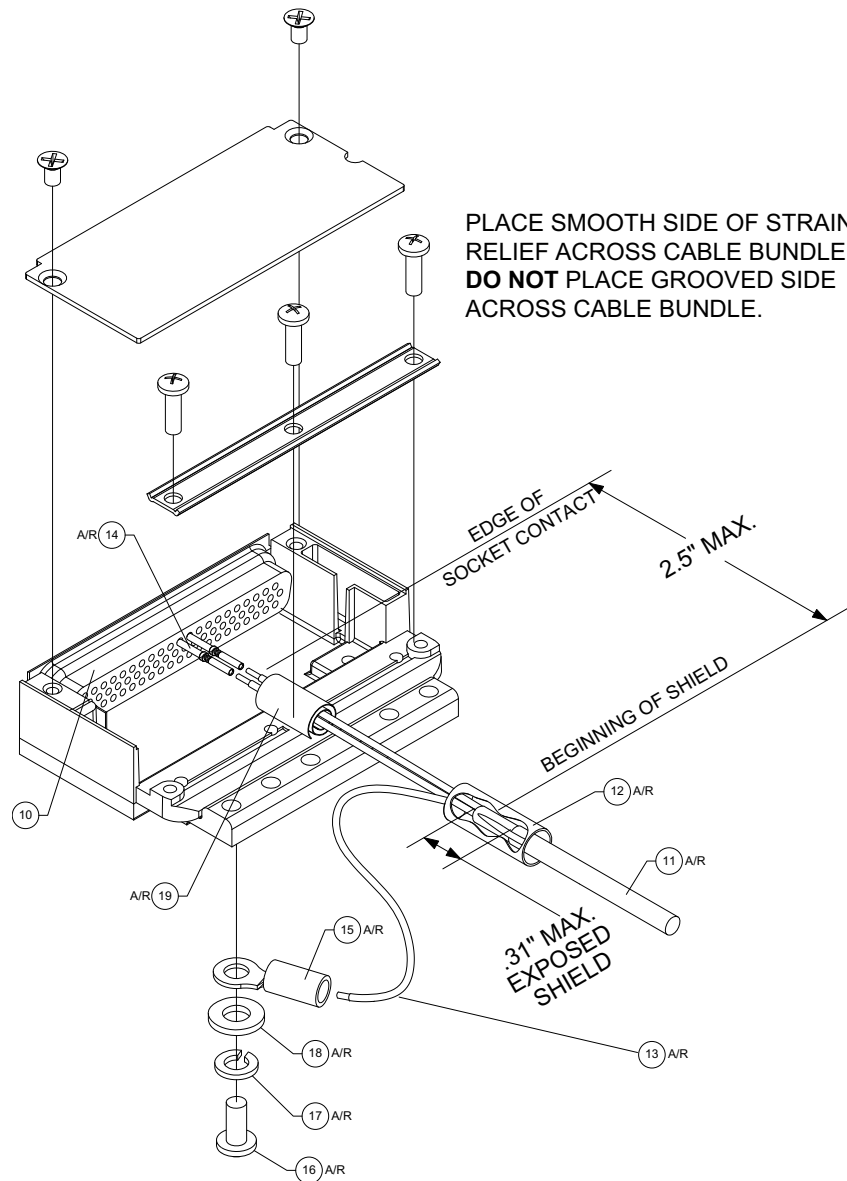

Figure 4-2 Shield Termination on Backshell Assembly

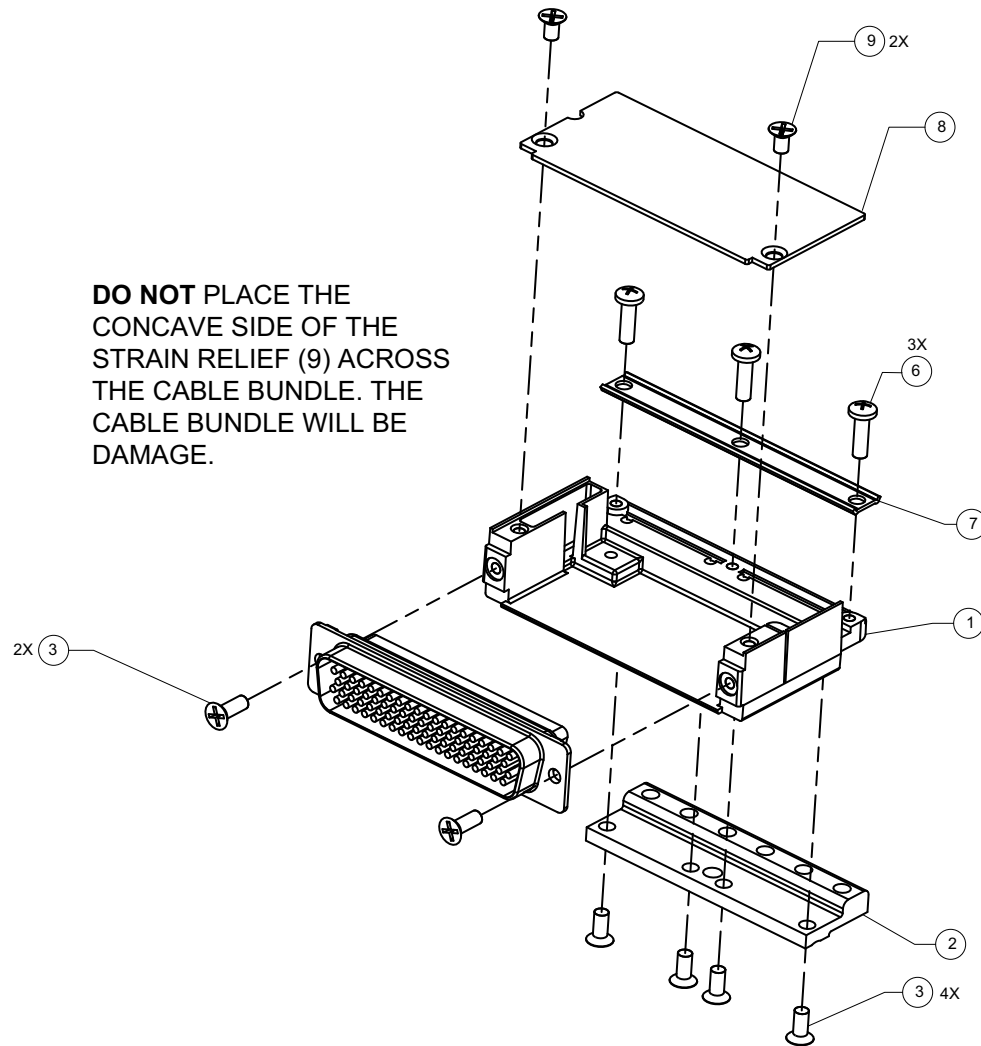

Figure 4-3 Connector and Backshell Assembly

4.5 Configuration Module Installation



NOTE

Installations with an optional GAE module do not require a configuration module.



NOTE

The configuration module stores unit configuration data. This lets the installer remove and replace the GTX without loss of configuration data. Installation of the module is part of the aircraft harness.

GTX 335 and GTX 345 standard kits include a configuration module. Garmin recommends to use the configuration module with these models, but it is not required.

Do not install the configuration module in the connector backshell when the GAE is installed on the connector backplate. The GAE module has a built-in configuration data storage device and interfaces to the GTX 3X5 through the same pins as the configuration module.

The GAE wire harness is routed out the back of the backshell and plugged into the GAE when the backplate is assembled. Refer to section 5.12 and figure B-11.

Refer to figure 4-4 and figure D-1 for this procedure.

1. Remove 0.17 inches of insulation from the end of each wire (2) before crimping.
2. Crimp socket contacts (3) onto each wire of the four-conductor wire harness (2).
3. Insert crimped socket contacts (3) and wires (2) into the applicable connector housing location. Refer to figure D-1.
4. Plug the four-conductor wire harness (2) into the connector on the configuration module (1).
5. Insert configuration module (1) into the backshell recess.
6. Point the connector housing so the inserted four conductor wire harness (2) is on the same side of the backshell as the configuration module (1).

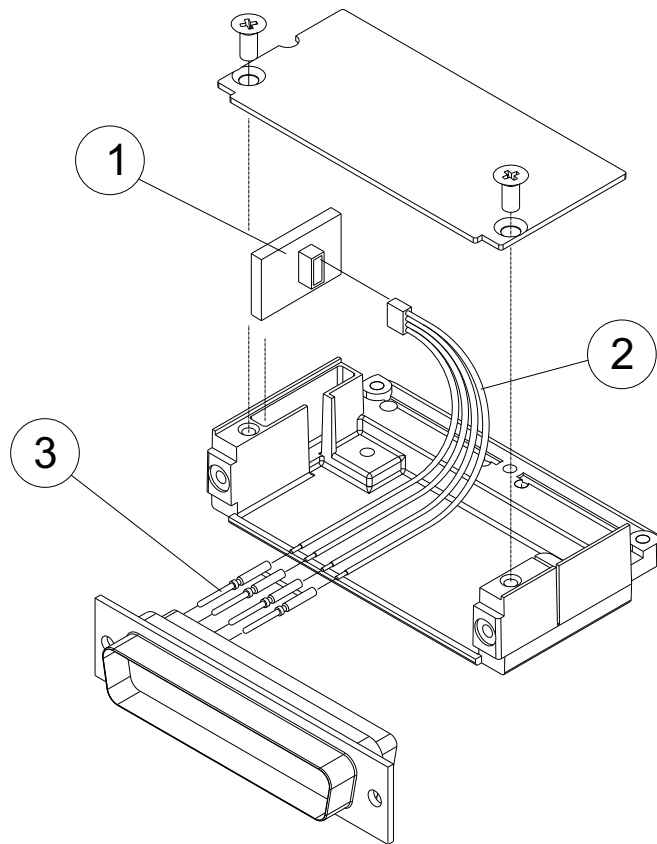

Figure 4-4 Configuration Module Installation

Table 4-2 Configuration Module Kit, P/N 011-00979-03

Refer to Figure	Description	Garmin P/N
1	Sub-assembly, potted configuration module, with EEPROM	011-02178-00
2	4-conductor harness	325-00122-00
3	Socket contact, crimp #22D	336-00021-01

4.6 Coax Cable Installation



NOTE

Make sure the length is set for the necessary cable loss. Some antennas have minimum cable loss specifications, that may need a cable longer than the physical run in the aircraft.

Follow the steps below for installation of the coaxial cables.

1. Route the coaxial cable to the radio rack location keeping in mind the recommendations of section 3.14.
2. Attach the cable in accordance with AC 43.13-1B chapter 11, section 11.
3. Trim the coaxial cable to the applicable length.
4. Install the coaxial connectors per the manufacturer's instructions.

4.7 Equipment Rack Installation

4.7.1 Panel Mount Units



CAUTION

Exercise caution when installing the rack in the instrument panel. Deformation of the rack will make it difficult to install and remove the GTX 3X5.



NOTE

If the front lip of the mounting rack is behind the surface of the aircraft panel, the GTX 3X5 connectors may not fully engage. Refer to appendix B for more information.



NOTE

Make sure no screw heads or other obstructions prevent the unit from fully engaging in the rack. Refer to figure B-9 for drawing dimensions necessary to prepare the cutouts for the GTX 3X5 unit. The GTX 3X5 mounting rack may also be used as a template for drilling the mounting holes.



NOTE

Step 3 can be done before or after the wire harness is installed in the aircraft.

1. Install the rack in a rectangular hole (or gap between units) in the instrument panel, typically in the radio stack. The lower front lip of the rack should be flush with, or extend slightly beyond, the finished aircraft panel.
2. Use six #6-32 flat head screws and self-locking nuts to install the rack in the aircraft panel. The screws are inserted from the inside through holes in the sides of the rack.
3. Use provided screws to attach the connector(s) to the backplate.
4. Align the backplate so the backplate screw heads pass through the keyed holes in the back of the rack.
5. Use two #4-40 flat head screws to attach the GAE to the backplate, if used. Refer to figure B-11.
6. Connect the wire harness to the GAE, if used. Refer to figure B-9.
7. Slide the backplate to the left (viewing from the front of the unit) until an audible click is heard.
8. Attach the backplate by tightening the four #4-40 screws.

4.7.2 Standard Remote Mount Units



NOTE

The Bluetooth antenna in the GTX 345 is at the front of the unit and must point to the passenger area to provide the best Bluetooth connection. Bluetooth performance from a remote unit can be limited due to obstructions in the aircraft. In this situation, better performance can be obtained by using a Flight Stream 110/210.

The GTX 3X5 standard remote mount racks can be mounted in any orientation as long as all six mounting screws are attached to a mounting bracket. Design the mounting bracket(s) for the GTX 3X5 unit with the dimension shown in figure B-4.

Attach the connectors and optional GAE, if used, to the connector backplate the same way as panel mount units. Refer to section 4.7.1.

4.7.3 Vertical Remote Mount Units



NOTE

The Bluetooth antenna in the GTX 345 is at the front of the unit and must point to the passenger area to provide the best Bluetooth connection. Bluetooth performance from a remote unit can be limited due to obstructions in the aircraft. In this situation, better performance can be obtained by using a Flight Stream 110/210.

The GTX 3X5 vertical remote mount base is installed in the vertical orientation with six #10-32 100° flat-head screws and locking nuts. Refer to figure B-6 for mounting hole spacing dimensions. The base may also be used as a template to mark or drill the mounting holes.

Point the wedge-shaped end of the vertical remote mount shoe to the back of the unit. Attach the vertical remote mount shoe to the unit with the four screws provided. Torque the screws to 15-16 in-lbs.

Attach the connectors and optional GAE, if used, to the connector backplate the same way as panel mount units. Refer to section 4.7.1.

4.7.4 GX000 Integrated Flight Decks

The GTX 3X5 G1000 rack is mounted to the main system rack with the nutplate kit listed in section 3.4.2. At least eight screws are required to secure the rack as shown in figure B-7. Refer to *G1000 System Installation Manual*. Attach the connectors and optional GAE, if used, to the connector backplate the same way as panel mount units. Refer to section 4.7.1.

4.8 Panel and Standard Remote Mount Unit Installation and Removal



CAUTION

The application of hex drive tool torque more than 8 in-lbs can damage the locking mechanism.



NOTE

When a unit is installed make sure it successfully powers up. Refer to section 6 for configuration procedures.



NOTE

Before placing the unit in the rack, in order to make sure the position of the retention mechanism is correct, it can be necessary to insert the hex drive tool into the access hole and turn the hex drive tool counterclockwise until it fully stops.

Insertion

1. Slide unit in until it stops, approximately 3/8 inch short of the final position.
2. Insert a 3/32" hex drive tool into the access hole at the bottom of the unit face.
3. Push on the left side of the bezel and turn hex drive tool clockwise and apply 8 in-lbs of torque.

Removal

1. Insert the hex drive tool into the access hole on the unit face.
2. Turn hex drive tool counterclockwise until the hex drive tool stops.
3. Pull the unit from the rack.

4.9 Vertical Remote Mount Unit Installation and Removal



NOTE

When a unit is installed make sure it successfully powers up. Refer to section 6 for configuration procedures.



NOTE

The connector backplate can be attached/detached before or after the installation/removal of the GTX 3X5 onto the base.

Insertion

1. Insert the toe of the GTX 3X5 shoe into the base at an angle.
2. Make sure the unit is fully engaged and in line with the base.
3. Rotate the GTX 3X5 down flat onto the base.
4. Rotate the base locking mechanism up and place the cup over the shoe.
5. Rotate the knob clockwise until tight.
6. Directly attach the connector backplate to the GTX 3X5 with two screws using a 3/32" hex tool.

Removal

1. On the base, pull the knob back.
2. Rotate knob counter-clockwise.
3. Remove the cup off of the shoe.
4. Lift the end of the GTX 3X5 from the base and remove the unit.
5. Detach the connector backplate from the GTX 3X5 with a 3/32" hex tool.

5 CONNECTOR PINOUT INFORMATION

5.1	Main Board Connector - P3251	5-2
5.2	ADS-B Board Connector – P3252 (GTX 345 Only)	5-5
5.3	Power	5-6
5.3.1	Power Configuration and Control Inputs	5-6
5.4	Lighting Bus	5-7
5.5	Altitude Inputs	5-7
5.5.1	Pressure Sensor Module	5-7
5.5.2	Gray Code Altitude Input	5-8
5.6	Discrete I/O	5-8
5.7	Serial Data Interfaces	5-9
5.7.1	RS-232	5-9
5.7.2	ARINC 429	5-9
5.7.3	HSDB	5-10
5.7.4	RS-422	5-10
5.8	Suppression Bus	5-10
5.9	OAT Input	5-10
5.10	Audio Output	5-11
5.11	Time Mark	5-11
5.12	Configuration Module	5-11
5.13	USB Interface	5-12

5.1 Main Board Connector - P3251

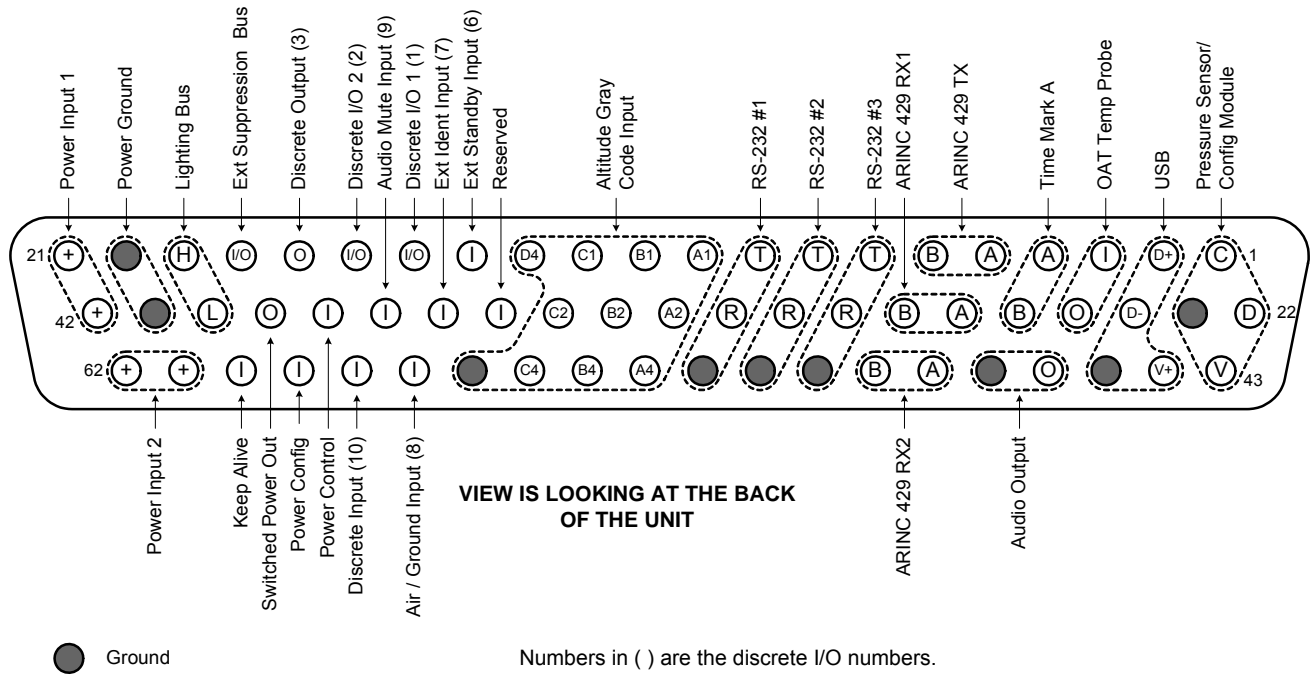

Table 5-1 P3251 Connector

Pin	Pin Name	I/O
1	ALT ENCODER/CONFIG MODULE CLOCK	I/O
2	USB DATA HI	I/O
3	TEMP PROBE IN	I
4	TIME MARK A	I/O
5	ARINC 429 OUT A	O
6	ARINC 429 OUT B	O
7	RS-232 OUT 3	O
8	RS-232 OUT 2	O
9	RS-232 OUT 1	O
10	ALTITUDE A1* or CONFIGURABLE*	I
11	ALTITUDE B1* or CONFIGURABLE*	I
12	ALTITUDE C1* or CONFIGURABLE*	I
13	ALTITUDE D4* or CONFIGURABLE*	I
14	EXTERNAL STANDBY SELECT* or CONFIGURABLE*	I
15	CONFIGURABLE DISCRETE 1*	I/O
16	CONFIGURABLE DISCRETE 2*	I/O
17	XPDR FAIL 1* or CONFIGURABLE*	O
18	EXTERNAL SUPPRESSION	I/O

Pin	Pin Name	I/O
19	LIGHTING BUS HI	I
20	AIRCRAFT GROUND	I
21	AIRCRAFT POWER 1	I
22	ALT ENCODER/CONFIG MODULE DATA	I/O
23	ALT ENCODER/CONFIG MODULE GND	O
24	USB DATA LO	I/O
25	TEMP PROBE OUT	O
26	TIME MARK B	I/O
27	ARINC 429 IN 1A	I
28	ARINC 429 IN 1B	I
29	RS-232 IN 3	I
30	RS-232 IN 2	I
31	RS-232 IN 1	I
32	ALTITUDE A2* or CONFIGURABLE*	I
33	ALTITUDE B2* or CONFIGURABLE*	I
34	ALTITUDE C2* or CONFIGURABLE*	I
35	RESERVED	I
36	EXTERNAL IDENT SELECT* or CONFIGURABLE*	I
37	AUDIO INHIBIT 2* or CONFIGURABLE*	I
38	POWER CONTROL*	I
39	SWITCHED POWER OUT	O
40	LIGHTING BUS LO	I
41	AIRCRAFT GROUND	--
42	AIRCRAFT POWER 1	I
43	ALT ENCODER/CONFIG MODULE POWER	O
44	USB VBUS POWER	I
45	USB GND	--
46	AUDIO OUT HI	O
47	AUDIO OUT LO	O
48	ARINC 429 IN 2A	I
49	ARINC 429 IN 2B	I
50	RS-232 GND 3	--
51	RS-232 GND 2	--
52	RS-232 GND 1	--

Pin	Pin Name	I/O
53	ALTITUDE A4* or CONFIGURABLE*	I
54	ALTITUDE B4* or CONFIGURABLE*	I
55	ALTITUDE C4* or CONFIGURABLE*	I
56	ALTITUDE GROUND	O
57	SQUAT SWITCH* or CONFIGURABLE*	I
58	AIR DATA SELECT* or CONFIGURABLE*	I
59	POWER CONFIG*	I
60	GPS KEEP ALIVE	I
61	AIRCRAFT POWER 2	I
62	AIRCRAFT POWER 2	I

An asterisk (*) following a signal name denotes the signal is an Active-Low discrete, requiring a ground to activate. If there is no asterisk, the signal is an Active-High.

5.2 ADS-B Board Connector – P3252 (GTX 345 Only)

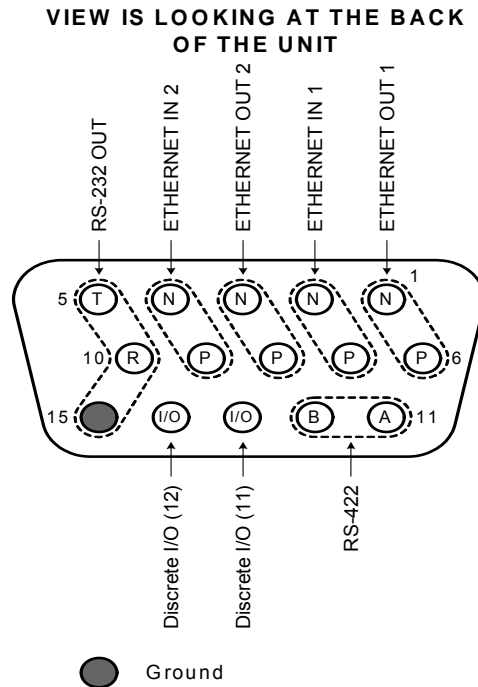

Table 5-2 P3252 Connector

Pin	Pin Name	I/O
1	ETHERNET OUT 1B	O
2	ETHERNET IN 1B	I
3	ETHERNET OUT 2B	O
4	ETHERNET IN 2B	I
5	RS-232 OUT 4	O
6	ETHERNET OUT 1A	O
7	ETHERNET IN 1A	I
8	ETHERNET OUT 2A	O
9	ETHERNET IN 2A	I
10	RS-232 IN 4	I
11	RS-422 A	O
12	RS-422 B	O
13	CONFIGURABLE DISCRETE 11*	I/O
14	CONFIGURABLE DISCRETE 12*	I/O
15	RS-232 GND 4	--

An asterisk (*) following a signal name denotes the signal is an Active-Low discret, requiring a ground to activate. If there is no asterisk, the signal is an Active-High.

5.3 Power

The GTX 3X5 is compatible with 14 VDC and 28 VDC aircraft electrical systems. The AIRCRAFT POWER 2 input is diode-isolated from AIRCRAFT POWER 1 and is used for connecting to an alternate power source, such as on an aircraft with two electrical buses.

Table 5-3 Power Pins

Pin Name	Connector	Pin	I/O
AIRCRAFT POWER 1	P3251	21	I
AIRCRAFT POWER 1	P3251	42	I
AIRCRAFT POWER 2	P3251	61	I
AIRCRAFT POWER 2	P3251	62	I
AIRCRAFT GROUND	P3251	20	--
AIRCRAFT GROUND	P3251	41	--
SWITCHED POWER OUT	P3251	39	O
GPS KEEP ALIVE [1]	P3251	60	I

Notes:

[1] Applicable to the GTX 335 and GTX 345 with internal GPS only.

The SWITCHED POWER OUT pin is a switched power output source, typically used for powering devices such as a remote altitude encoder module. It is active when the GTX 3X5 power is on, and has a 1 ampere max rating.

On models with built-in GPS/SBAS, the GPS KEEP ALIVE input requires continuous battery power. This battery input maintains the internal GPS clock and decreases initial GPS satellite acquisition time during system power-up.

5.3.1 Power Configuration and Control Inputs

The power control inputs are for remote power on/off and enabling the power auto on feature.

The POWER CONFIG input controls the remote on/off feature. The POWER CONFIG input connects to ground for remote unit installation. The input is left open for panel mount unit installation.

The POWER CONTROL connection controls the POWER CONTROL input. This is used as a remote power on/off control or to use the power auto on feature when the avionics master is turned on.

Table 5-4 Power Configuration and Control Inputs

Pin Name	Connector	Pin	I/O
POWER CONFIG	P3251	59	I
POWER CONTROL	P3251	38	I

Table 5-5 Power Configuration and Power Control Functions

POWER CONFIG	POWER CONTROL	Unit Type	Description
Open	Open	Panel mount	Auto on disabled, momentary power switch enabled
Open	Ground	Panel mount	Auto on enabled, momentary power switch enabled
Ground	Open	Remote	Power off
Ground	Ground	Remote	Power on

5.4 Lighting Bus

The lighting bus input controls the front panel display and keypad brightness of panel mount units using the aircraft panel lighting bus. The GTX 3X5 can also be configured to adjust the display and keypad brightness for ambient lighting conditions using an internal photo sensor.

The lighting bus input is configured for 5 VDC, 14 VDC, 28 VDC, or 5 VAC inputs.

Use both the LIGHTING BUS HI and LIGHTING BUS LO inputs to connect the lighting bus input to a 5 VAC bus.

Use the LIGHTING BUS HI input to connect the light bus input to a DC input. The return is the unit ground connection. LIGHTING BUS LO should be left open.

Table 5-6 Lighting Bus Pins

Pin Name	Connector	Pin	I/O
LIGHTING BUS HI	P3251	19	I
LIGHTING BUS LO	P3251	40	I

5.5 Altitude Inputs

The GTX 3X5 uses pressure altitude inputs from several different sources:

- Gray code inputs
- RS-232 serial inputs
- ARINC 429 inputs
- The optional GAE module (Garmin P/N 011-03080-00)
- HSDB

Refer to section 3.10 for altitude source priorities. With the proper encoder, the Mode S transponder transmits altitude reporting in 25-foot resolution to ground stations and other aircraft. The unit must receive altitude from an applicable altitude reporting device or from the optional GAE module. A parallel Gray code encoder provides altitude in 100 foot resolution.

For altitude encoders that supply both a serial interface and the parallel Gray code input, such as the GAE 43 (P/N 013-00066-00), connect one or the other interfaces, but not both. The serial interface is preferred.

5.5.1 Pressure Sensor Module

The optional GAE module (Garmin P/N 011-03080-00) is used for the GTX 3X5 pressure altitude input. It uses the same interface as the configuration module and also includes the configuration module functionality.

5.5.2 Gray Code Altitude Input

The GTX 3X5 accepts ten Gray code altitude discrete inputs.

The Gray code inputs are pulled down for active, or open for inactive.

The GTX 3X5 includes internal isolation diodes on the Gray code inputs to prevent the unit from pulling the encoder lines to ground when the transponder is turned off.

Table 5-7 Altitude Inputs

Pin Name	Connector	Pin	I/O
ALTITUDE A1* or CONFIGURABLE*	P3251	10	I
ALTITUDE A2* or CONFIGURABLE*	P3251	32	I
ALTITUDE A4* or CONFIGURABLE*	P3251	53	I
ALTITUDE B1* or CONFIGURABLE*	P3251	11	I
ALTITUDE B2* or CONFIGURABLE*	P3251	33	I
ALTITUDE B4* or CONFIGURABLE*	P3251	54	I
ALTITUDE C1* or CONFIGURABLE*	P3251	12	I
ALTITUDE C2* or CONFIGURABLE*	P3251	34	I
ALTITUDE C4* or CONFIGURABLE*	P3251	55	I
ALTITUDE D4* or CONFIGURABLE*	P3251	13	I
ALTITUDE GROUND	P3251	56	O

5.6 Discrete I/O

Active-Low discrete inputs are considered active if either the voltage to ground is <3.5 VDC or the resistance to ground is <375 ohms. These inputs are considered inactive if the voltage to ground is 6.5-33 VDC or the resistance to ground is >100 kilohm.

The GTX 3X5 has discrete outputs that are configurable. Each is an open drain output capable of sinking 250 milliamp when active. Refer to table 6-7 and table 6-8 for discrete input and output configuration.

Table 5-8 Discrete Inputs and Outputs

Pin Name	Connector	Pin	I/O
EXTERNAL STANDBY SELECT* or CONFIGURABLE*	P3251	14	I
XPDR FAIL 1* or CONFIGURABLE*	P3251	17	O
EXTERNAL IDENT SELECT* or CONFIGURABLE*	P3251	36	I
AUDIO INHIBIT 2* or CONFIGURABLE*	P3251	37	I
SQUAT SWITCH* or CONFIGURABLE*	P3251	57	I
AIR DATA SELECT* or CONFIGURABLE*	P3251	58	I
CONFIGURABLE DISCRETE 1*	P3251	15	I/O
CONFIGURABLE DISCRETE 2 *	P3251	16	I/O
CONFIGURABLE DISCRETE 11*	P3252	13	I/O
CONFIGURABLE DISCRETE 12*	P3252	14	I/O

5.7 Serial Data Interfaces

5.7.1 RS-232

The RS-232 outputs are compatible with EIA Standard RS-232C with an output voltage swing of at least ± 5 V when driving a standard RS-232 load. The RS-232 inputs and outputs can be configured for different functions depending on the installation. Refer to section 6.5. Pins P3252-5, -10, and -15 are on the GTX 345 only.

Table 5-9 RS-232 Inputs and Outputs

Pin Name	Connector	Pin	I/O
RS-232 OUT 1	P3251	9	O
RS-232 IN 1	P3251	31	I
RS-232 GND 1	P3251	52	O
RS-232 OUT 2	P3251	8	O
RS-232 IN 2	P3251	30	I
RS-232 GND 2	P3251	51	--
RS-232 OUT 3	P3251	7	O
RS-232 IN 3	P3251	29	I
RS-232 GND 3	P3251	50	---
RS-232 OUT 4	P3252	5	O
RS-232 IN 4	P3252	10	I
RS-232 GND 4	P3252	15	O

5.7.2 ARINC 429

The ARINC 429 output conforms to the ARINC 429 electrical specification when loaded with up to five standard ARINC 429 receivers. The ARINC 429 inputs and outputs can be configured for different functions depending on the installation. Refer to section 6.5.

Table 5-10 ARINC 429 Inputs and Outputs

Pin Name	Connector	Pin	I/O
ARINC 429 OUT A	P3251	5	O
ARINC 429 OUT B	P3251	6	O
ARINC 429 IN 1A	P3251	27	I
ARINC 429 IN 1B	P3251	28	I
ARINC 429 IN 2A	P3251	48	I
ARINC 429 IN 2B	P3251	49	I

5.7.3 HSDB

Table 5-11 Ethernet Inputs and Outputs

Pin Name	Connector	Pin	I/O
ETHERNET OUT 1A	P3252	6	O
ETHERNET OUT 1B	P3252	1	O
ETHERNET IN 1A	P3252	7	I
ETHERNET IN 1B	P3252	2	I
ETHERNET OUT 2A	P3252	8	O
ETHERNET OUT 2B	P3252	3	O
ETHERNET IN 2A	P3252	9	I
ETHERNET IN 2B	P3252	4	I

5.7.4 RS-422

The RS-422 interface conforms to the electrical specifications of EIA standard RS-422.

Table 5-12 RS-422 Outputs

Pin Name	Connector	Pin	I/O
RS-422 A	P3252	11	O
RS-422 B	P3252	12	O

5.8 Suppression Bus

The EXTERNAL SUPPRESSION is intended for connection to other L-band equipment, such as a DME or UAT. The output is active whenever the GTX 3X5 transmits. When driven by another source, the GTX 3X5 transponder receiver and transmitter functions will be suppressed.

The EXTERNAL SUPPRESSION output is driven to ≥ 18 VDC when the GTX 3X5 transmits. An input voltage of ≥ 10 VDC will suppress the GTX 3X5.

Table 5-13 External Suppression Bus Pin

Pin Name	Connector	Pin	I/O
EXTERNAL SUPPRESSION	P3251	18	I/O

5.9 OAT Input

The GTX 3X5 includes an OAT input, used for OAT and density altitude displays.

TEMP PROBE IN uses a current sensor type probe, such as the EDMO P/N 655-PROBE or the Davtron P/N C307PS. The temperature input specification is 1 microamp per degree Kelvin (1 μ A/ $^{\circ}$ K). Connect the probe red wire to pin 25 and the black wire to pin 3.

Table 5-14 OAT Input and Output

Pin Name	Connector	Pin	I/O
TEMP PROBE OUT	P3251	25	O
TEMP PROBE IN	P3251	3	I

5.10 Audio Output

The audio output is used to provide aural traffic alerts. The output is capable of 100 mW into a 500 ohm load.

Table 5-15 Audio Inputs and Outputs

Pin Name	Connector	Pin	I/O
AUDIO OUT HI	P3251	46	O
AUDIO OUT LO	P3251	47	O

5.11 Time Mark

Table 5-16 Time Mark Outputs

Pin Name	Connector	Pin	I/O
TIME MARK A	P3251	4	O
TIME MARK B	P3251	26	O

With either a GTX 335 or GTX 345 with internal GPS, the TIME MARK can be used as an output to provide 1PPS to other equipment in the aircraft.

5.12 Configuration Module

The configuration module interface is used for connection to either a configuration module or an optional GAE module.

The configuration and GAE module kits include a wire harness for connection to the GTX 3X5 D-sub connector. Connect using The wire colors are shown in table 5-17.

The configuration module stores the specified aircraft installation configuration settings.

The optional GAE module is used to provide the pressure altitude for the transponder. The GAE module also includes configuration memory function to store the installation configuration. When used, A separate configuration module is not necessary.

Table 5-17 Configuration Module Inputs and Outputs

Pin Name	Color	Connector	Pin	I/O
ALT ENCODER/CONFIG MODULE CLOCK	White	P3251	1	O
ALT ENCODER/CONFIG MODULE DATA	Yellow	P3251	22	I/O
ALT ENCODER/CONFIG MODULE POWER	Red	P3251	43	O
ALT ENCODER/CONFIG MODULE GROUND	Black	P3251	23	O

5.13 USB Interface



CAUTION

Use the USB cable shipped with the unit. Do not lengthen or tie up in bundles with other electrical wires. Potential damage or interference due to coupling with other cables will occur.

Only use the USB interface for unit configuration, software updates, and service while the aircraft is on the ground. Do not use during normal operation or when airborne.

Table 5-18 USB Inputs and Outputs

Pin Name	Connector	Pin	I/O
USB DATA HI	P3251	2	I/O
USB DATA LO	P3251	24	I/O
USB VBUS POWER	P3251	44	I
USB GND	P3251	45	O

6 POST INSTALLATION CONFIGURATION AND CHECKOUT

6.1	System Configuration Overview	6-1
6.2	Mounting, Wiring, and Power Checks	6-1
6.3	Configuration Mode and Settings	6-2
6.4	Audio Settings	6-3
6.5	Interfaces	6-5
6.6	Unit Settings	6-14
6.7	Display Pages	6-17
6.8	Sensors	6-20
6.9	ADSB	6-25
6.10	Diagnostics	6-30
6.11	Remote Unit Configuration	6-32
6.12	Ground Check - GPS Reception Check	6-40
6.13	Software Installation Procedure	6-41

6.1 System Configuration Overview

The required GTX 3X5 configuration and checkout procedures are as follows:

- Complete the installation checks.
- Configure the GTX 3X5 for the specified installation.
- Complete ground checks to make sure it interfaces to external equipment.

6.2 Mounting, Wiring, and Power Checks



CAUTION

Make sure all lighting buses are turned to their lowest adjustment before applying power to the unit. The lowest adjustment prevents damage to the unit if there are any wiring errors.

Examine the wire harness to make sure the connection to aircraft systems and avionics equipment is correct before the unit is energized. Point-to-point continuity must be examined to expose any faults such as shorting to ground or wiring discrepancies. All faults or discrepancies must be corrected before continuing.

Before and during the installation make sure:

- All cables are properly attached.
- Shields are connected to connector shield blocks.
- Movement of the flight and engine controls through the full range of motion do not touch cabling and control systems.
- Wire is installed as described in section 3.14.

Make sure these items are completed after the installation or a continuity check.

- Power and ground checks.
- Faults and discrepancies are corrected.
- Installation rack is correctly attached.
- Unit is correctly seated in the installation rack.

6.3 Configuration Mode and Settings



NOTE

Screenshots are for illustrative purposes only. They do not imply the shown setting(s) should be used in any installation.

System and interface settings are shown in configuration mode and are unique to the GTX 3X5 installation. The configuration settings are stored in internal memory. If connected, the configuration module stores configuration settings. The optional GAE module operates as a configuration module. In this section, configuration instructions are for panel mount units. Refer to section 6.11 to configure remote units.

On a panel mount unit push and hold the **ENT** key and apply power to enter configuration mode.

- Push and hold the **OFF** key until the unit powers off to exit configuration mode.
- Push the **FUNC** key to cycle through the group pages.
- Push the **8** or **9** key to scroll up or down on the page without an active field selected.
- Push the **CRSR** key to access items on the page.
- Push the **8** or **9** key to cycle through the selections of an item on the page.
- Push the **ENT** key to move within the page with a field highlighted or to accept setting.
- Push the **CLR** key to move to previous selection on the page.
- Push the **FUNC** key to exit the page.

6.4 Audio Settings

Sets the audio output, volume, and alert types.

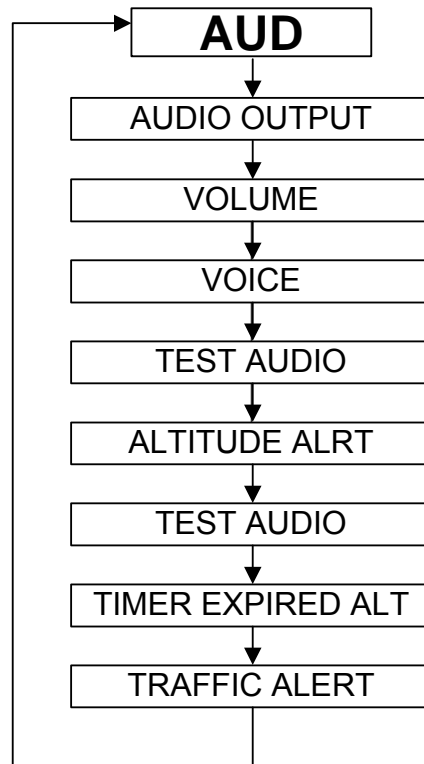

Figure 6-1 Audio Group

AUDIO OUTPUT

To use the audio output of the transponder, select XPDR. If installing a GTX 345 in a GX000 system, select HSDB.

VOLUME

To raise the volume of the transponder audio, push the **8** key. To lower the volume, push the **9** key. The range is 0 to 100.

VOICE

Set the voice type to MALE or FEMALE.

TEST AUDIO

The test audio files are used to set the volume level of the transponder. Selections are:

- NONE
- TONE
- MSG 1
- MSG 2
- MSG 3

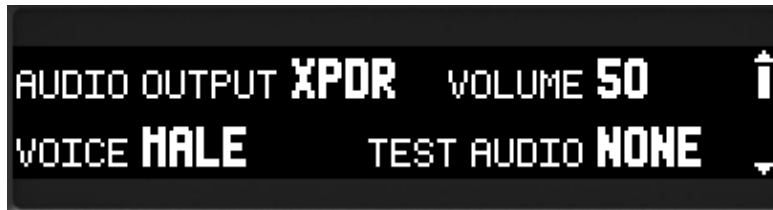

Figure 6-2 Audio Page

ALTITUDE ALRT (PANEL MOUNT UNITS ONLY)

Sets altitude alerting type. Selections are:

- OFF
- MESSAGE
- MSG W/CHIME

TIMER EXPIRED ALRT (PANEL MOUNT UNITS ONLY)

Sets timer expired alert type. Selections are:

- OFF
- MESSAGE
- MSG W/CHIME



Figure 6-3 Audio Page 2

TRAFFIC ALERT



NOTE

A chime is heard if the GTX 335 is configured for TIS-A traffic alerts.

Sets the traffic alerting type. Selections are:

- OFF
- MESSAGE
- MSG W/CHIME



Figure 6-4 Audio Page 3

6.5 Interfaces

Configures inputs and outputs of RS-232, ARINC 429, discretes, and HSDB interfaces.

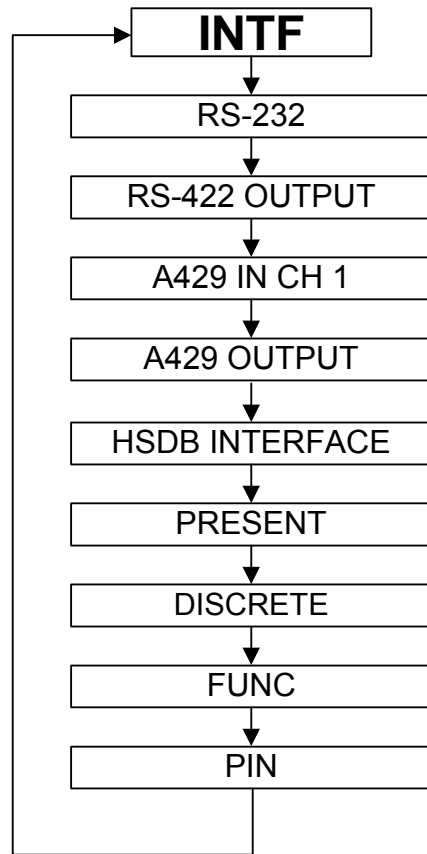

Figure 6-5 Interface Group

RS-232 - CHANNEL 1 THROUGH CHANNEL 3

Sets the input and output format for channel 1, channel 2, channel 3, and channel 4 of RS-232 interfaces. Refer to appendix A for data format information.

Table 6-1 RS-232 Channel 1 through Channel 3 Selections

Input/Output	Selection	Description	Unit Applicability	Notes
Input/Output	Off	No information is received or transmitted.	All	
Input/Output	XPDR FMT 1	Supports transponder interface to GX000.	All	
Input/Output	XPDR FMT 2	Supports transponder interface and TIS-A traffic to GX000.	GTX 335 only	
Input or Output	ADS-B+ FMT 1	Receives or transmits necessary ADS-B GPS data at 9600 baud.	All	[1]
Input or Output	ADS-B+ FMT 2	Receives or transmits necessary ADS-B GPS data at 38400 baud.	All	[1]
Input/Output	REMOTE FMT 1	Supports transponder interface to GTN and GNS 480 (CNX80).	All	
Input/Output	REMOTE FMT 2	Supports transponder interface and TIS traffic to GTN and GNS 480 (CNX80)	GTX 335 only	
Input/Output	GDL	Supports GDL 88 interface	All	[2]
Input/Output	GNS	Supports GNS 400W/500W Series ADS-B In weather. Traffic is supported over ARINC 429. Supplies GPS data.	GTX 345 only	
Input/Output	CONNEXT FMT 1	Supports G3X for ADS-B In weather and traffic.	GTX 345 only	
Input	CONNEXT FMT 3	Supports input from a Flight Stream 110/210.	GTX 345 only	
Input	ALT FMT 1 25ft	Supports Sandia/Icarus/ACK altitude format with 25 ft or lower encoding.	All	
Input	ALT FMT 1 100ft	Supports Sandia/Icarus/ACK altitude format with a parallel Gray source or 100 ft encoding.	All	
Input	ALT FMT 3 25ft	Supports Shadin altitude format with 25 ft or lower encoding.	All	
Input	ALT FMT 3 100ft	Supports Shadin altitude format with a parallel Gray code source or 100 ft encoding.	All	
Input	ADC FMT 1	Supports Shadin G/S/Z ADC formats.	All	
Input/Output	LGCY REMOTE 1	Supports transponder interface and TIS-A traffic to legacy G1000.	All	
Input/Output	LGCY REMOTE 2	Supports transponder interface and TIS-A traffic to legacy G1000.	GTX 335 only	

Input/Output	Selection	Description	Unit Applicability	Notes
Output	ALT FMT 1	Transmits pressure altitude in 25 to 100 ft resolution depending on the source of the data.	All	
Output	TIS-A OUT FMT	Transmits TIS-A traffic for non-certified displays: GPSMAP 396/496/695/696, G3X, G300	GTX 335 only	
Output	LGCY TRAFFIC	Supports GDL 90 traffic interface to legacy G1000.	GTX 345 only	

Notes:

[1] Output available only on GTX 335 with GPS and GTX 345 with GPS.

[2] Not supported by GDL 88 software v3.32 or earlier.

RS-232 - CHANNEL 4 (GTX 345 ONLY)

Table 6-2 RS-232 Channel 4 Selections

Input/Output	Selection	Description
Input/Output	OFF	Information is not received or transmitted.
Input/Output	GNS	Supports GNS 400W/500W Series ADS-B In weather. Traffic is supported over ARINC 429. Supplies GPS information.
Input/Output	CONNEXT FMT 1	Supports G3X for ADS-B In weather and traffic.
Input	CONNEXT FMT 3	Supports input from Flight Stream 110/210
Input/Output	TRAFFIC FMT 4	Supports Ryan TCAD.
Output	LGCY TRAFFIC	Supports GDL 90 enhanced traffic interface to legacy G1000.

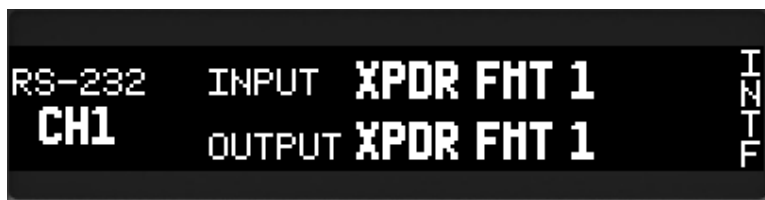

Figure 6-6 RS-232 Interface Page

RS-422 OUTPUT (GTX 345 ONLY)

RS-422 supports ADS-B In traffic and weather to the GMX 200 and MX20. Either format also provides weather to a legacy G1000 installation.

Table 6-3 RS-422 Selections

Channel	Input/Output	Selection	Description
RS-422	Output	CONNEXT FMT 3	Supports output to Flight Stream 210.
		OFF	Information is not transmitted.
		MX FMT 1	Supports GMX 200.
		MX FMT 2	Supports MX20.



Figure 6-7 RS-422 Output Page

A429 IN

Table 6-4 ARINC 429 Inputs

Channel/Speed	Format	Description	Notes
CH1/CH2 High/Low	OFF	Information is not received.	
	AHRS	Receives heading, roll, pitch, and yaw information from systems with AHRS.	
	ADC	Receives altitude, airspeed, and altitude rate information from air data systems.	
	ARINC 743A	Receives GPS information from ARINC 743A.	
	EFIS AIR DATA	Receives altitude, airspeed, altitude rate, and heading information from EFIS and ADC systems.	
	FLIGHT CONTROL	Receives selected altitude, barometric setting, and non-standard pitch discrete data for Bendix King KFC 225.	
	HEADING	Receives heading information.	
	MODE S CTRL PNL	Receives ARINC 718 labels for ATCRBS Control and Flight ID.	
	RADIO ALTITUDE	Receives radar altitude information.	
	TRAFFIC 1	Receives traffic information from Garmin GTX 800, GTS 820, and GTS 850 systems.	[1]
	TRAFFIC 2	Receives traffic information from L-3 Comm SKY497 Skywatch and SKY899 Skywatch HP.	[1]
	TRAFFIC 5	Receives traffic information from KTA 870 (KTA 810), KTA 970 (KTA 910), KMH 880 (KMH 820), and KMH 980 (KMH 920).	[1]

Notes

[1] Applicable to GTX 345 only.

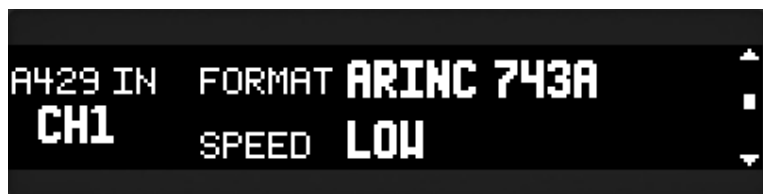

Figure 6-8 A429 In Page

A429 OUTPUT

Table 6-5 ARINC 429 Outputs

Format	Description	Notes
OFF	Information is not transmitted.	
FORMAT 1	Mode S control panel	
FORMAT 2	Garmin concentrator	
FORMAT 3	Garmin concentrator and Mode S control panel	
FORMAT 4	Garmin TAS and GPS data	
FORMAT 5	Garmin concentrator, Garmin TAS, and GPS data	
FORMAT 6	Mode S control panel, Garmin TAS, and GPS data	
FORMAT 7	Garmin concentrator, Mode S control panel, Garmin TAS, and GPS data	
FORMAT 8	Garmin TIS-A	[1]
FORMAT 9	Garmin concentrator and Garmin TIS-A	[1]
TRAFFIC	ADS-B traffic output for GNS 400W/500W Series units	[2]

Notes:

[1] Supported by the GTX 335 only.

[2] Supported by the GTX 345 only.



Figure 6-9 A429 Output Page

HSDB INTERFACE (GTX 345 ONLY)

Sets the presence of specified HSDB devices interfaced to the GTX 345. Selections are YES, NO.

Table 6-6 HSDB Formats

Interface	Description
GDU 620	Controls HSDB communication with the GDU 620, GTN 6XX/7XX, GTS 8X5, and GX000.
GTN	
GTS	
GX000	
Indirect A429 TCAS	The GTX receives traffic inputs from the GIA instead of TAS/TCAS in GX000 installations where TAS/TCAS is connected to a GIA, This interface is not shown on the display.



Figure 6-10 HSDB Interface Page

DISCRETE IN

Refer to section 5 for pinout information.



NOTE

The source priority is based upon the selections made during configuration. Refer to section 3.10.

Table 6-7 Discrete Inputs

Function	Selection	Description
AUD MUTE	All discrete inputs	The audio output will be muted until the discrete is opened. This is connected to a higher priority audio such as TAWS.
AUD CNCL	Off P3251-37	When this discrete is grounded by a momentary switch, audio alerts are canceled.
IDENT	Off P3251-36	When this discrete is grounded by a momentary switch, the SPI activates.
STANDBY	Off P3251-14	When this discrete is grounded, the unit will go into standby mode.
SQUAT	Off P3251-57	This input determines the on-ground status of the aircraft. It is active low, and a ground on this input can be configured to mean On Ground or In Air.
AIR DATA	Off P3251-58	Switches between two ARINC 429 ADC sources or two EFIS ADC sources. Source 1 and 2 are set during configuration. Source 1 is used when the discrete is open and Source 2 is used when the discrete is grounded.
ALT DATA	All discrete inputs	Selects between two pressure altitude sources.
ID SLCT	All discrete inputs on main board (P3251)	Selects the system ID and overrides configuration setting. GTX 1 system ID is selected when this discrete is open. GTX 2 system ID is selected when the discrete is grounded.
GILLHAM	On, Off	Activates all ten Gillham/Gray code inputs. If set to OFF, the input pins are available for configuration to other discrete input functions.
TIS-A	All discrete inputs	When this discrete is momentarily grounded, TIS-A will toggle between operate/standby.



Figure 6-11 Discrete In Page

DISCRETE OUT

Table 6-8 Discrete Outputs

Function	Pin Selection	Description
ALT ALERT	Off All discrete outputs on P3251	When this discrete is grounded, it indicates a deviation from the preset altitude setting.
FAIL 1	Off P3251-17	Failure of transponder causes discrete to ground.
FAIL 2	Off All discrete outputs on P3251 or P3252	Failure of transponder causes discrete to open.
RPLY ACTV	Off All discrete outputs on P3251 or P3252	Discrete grounds when transponder sends replies to interrogations.
EQUIP STS	Off All discrete outputs on P3251 or P3252	If the unit needs service soon, this discrete will switch between open and ground for the first 30 seconds after power up. If after 30 seconds, there is no detection of ADS-B In/Out failures the discrete opens. The discrete will ground if any ADS-B In/Out failures are detected after 30 seconds.
TRFC STBY	Off All discrete outputs on P3251	Commands TAS/TCAS standby/operate. Discrete output operation automatically sets through TAS/TCAS input configuration. GTX 345 only.
TRFC TEST	Off All discrete outputs on P3251	Commands TAS/TCAS into test mode. GTX 345 only.
TRFC ALRT	Off All discrete outputs on P3251 or P3252	When a traffic alert is active, this discrete will ground. GTX 345 only.
TCAD SL	Off All discrete outputs on P3251 or P3252	Supports automatic control and integration with Ryan TCAD and Avidyne TAS600 Series traffic systems. GTX 345 only.



Figure 6-12 Discrete Out Page

6.6 Unit Settings

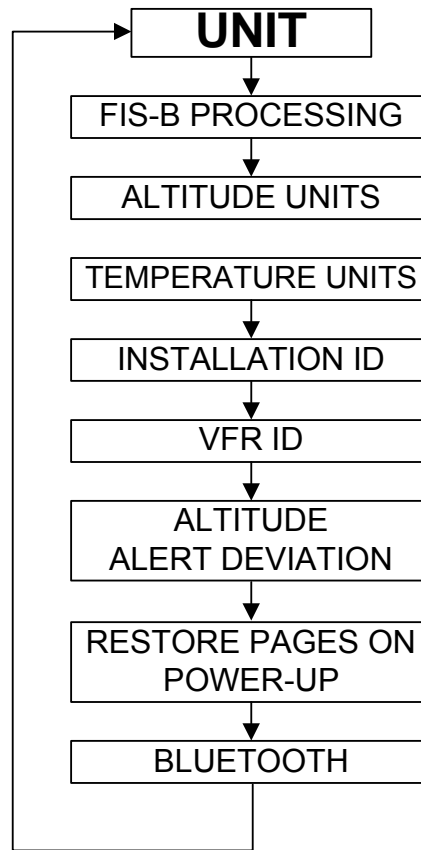

Figure 6-13 Unit Group

FIS-B PROCESSING (GTX 345 ONLY)

To receive ADS-B weather data, select ENABLED.



Figure 6-14 FIS-B Processing Page

ALTITUDE UNITS (PANEL MOUNT UNITS ONLY)

Sets pressure and density altitude units. Selections are:

- FLIGHT LVL
- FEET
- METERS

TEMPERATURE UNITS (PANEL MOUNT UNITS ONLY)

Sets temperature display units. Selections are:

- CELSIUS
- FAHRENHEIT



Figure 6-15 Altitude and Temperature Units Page

INSTALLATION ID



NOTE

The Installation ID Select discrete overwrites the configuration setting.

Selects the ID number for the transponder. Set the Installation ID to 1 in single installations. Set the primary transponder Installation ID to 1, and the secondary transponder to 2 in dual installations.

VFR ID

Sets the VFR squawk code for your country. Range in octal is 0000-7777.

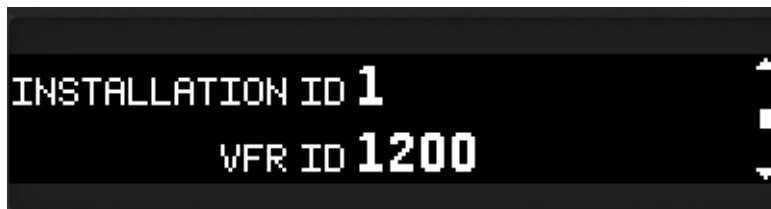

Figure 6-16 Installation and VFR ID Page

ALTITUDE ALERT DEVIATION (PANEL MOUNT UNITS ONLY)

This field determines the amount of altitude difference from selected altitude to generate an altitude alert. Range is 200 ft to 999 ft.

RESTORE PAGES ON POWER-UP (PANEL MOUNT UNITS ONLY)

To save the selected pages set in normal operating mode as the new default page settings next time the unit is power up, select YES.



Figure 6-17 Altitude Alert Deviation and Restore Page

BLUETOOTH (GTX 345 ONLY)

To transmit information to a PED using Bluetooth, select ENABLED.



Figure 6-18 Bluetooth Page

6.7 Display Pages



NOTE

Make sure the brightness levels match the lighting levels of other equipment in the panel under night conditions.

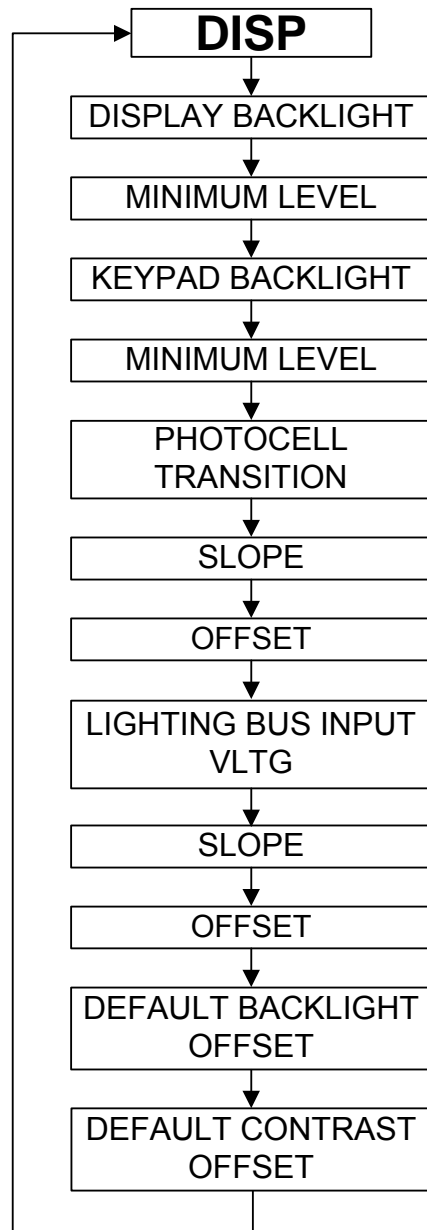

Figure 6-19 Display Group



Figure 6-20 Display Pages

DISPLAY BACKLIGHT

Sets the source for the display backlight control and adjustment. Select PHOTOCELL if the lighting level uses ambient lighting. Select LIGHTING BUS if an input from the lighting bus is used to dim the display.

MINIMUM LEVEL

Sets the minimum brightness of the display. The range is 0 to 100. The higher the number, the brighter the minimum brightness.

KEYPAD BACKLIGHT

Sets the source for the keypad backlight control and adjustment. Select PHOTOCELL if the lighting level uses ambient lighting. Select LIGHTING BUS if an input from the lighting bus is used to dim the keypad.

MINIMUM LEVEL

Sets the minimum brightness of the keypad. The range is 0 to 100. The higher the number, the brighter the minimum brightness.

PHOTOCELL TRANSITION

Sets a point on the lighting bus. When the lighting bus is below this point, the GTX 3X5 uses the photocell to adjust the display brightness. The range is 5 to 50.

PHOTOCELL SLOPE

Sets the sensitivity of the photocell input level. Adjusting the slope higher results in a greater display brightness change for a given increase in the photocell input level. The range is 0 to 100.

OFFSET

Adjusts the lighting level up or down for any given photocell input level. This field has a range of 0 to 100. Use the offset setting to match lighting curves with other equipment in the panel.

LIGHTING BUS INPUT VLTG

Sets the voltage of the lighting bus source. Selections are:

- 14 VDC
- 28 VDC
- 5 VDC
- 5 VAC

DISPLAY AND BEZEL KEY LIGHTING SLOPE

Sets the sensitivity of the display or bezel keys for any given lighting bus input level. Set the slope higher for a brighter display for a given increase in the lighting bus input level. This field has a range of 0 to 100.

DISPLAY AND BEZEL KEY OFFSET

Sets the lighting level up or down for any given lighting bus input level. This field has a range of 0 to 100. Use the offset setting to match lighting curves with other equipment in the panel.

DEFAULT BACKLIGHT OFFSET

Manually sets the default backlight offset value from -10 to 99.

DEFAULT CONTRAST OFFSET

Manually sets the default contrast offset value from -50 to 50.

6.8 Sensors

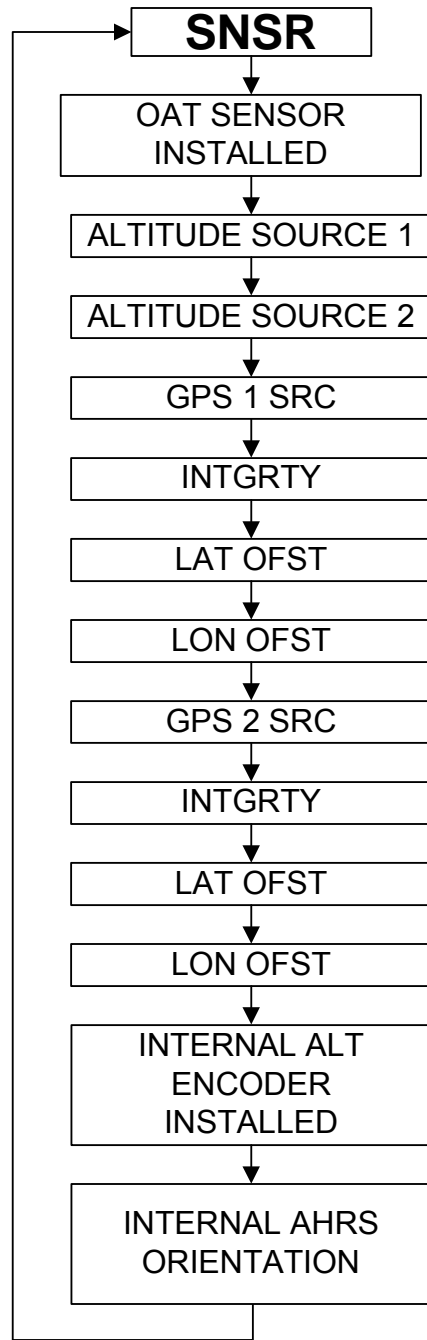

Figure 6-21 Sensor Group

OAT SENSOR INSTALLED

Select YES if an OAT sensor is installed.

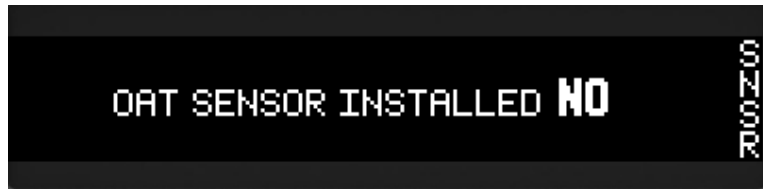

Figure 6-22 Sensor Page

ALTITUDE SOURCE 1 (GTX 345 ONLY)



NOTE

Altitude sources do not need to be set. The GTX 3X5 uses both altitude sources if set. The GTX uses any altitude source in priority order if no altitude sources are selected. Refer to section 3.10.

Sets the primary altitude source. Selections are:

- NONE
- A429 1
- ALT ENC
- RS232 1
- A429 2
- RS232 2
- HSDB (GTX 345 only)
- RS232 3
- GILLHAM

ALTITUDE SOURCE 2

Sets the secondary altitude source. Selections are:

- NONE
- A429 1
- ALT ENC
- RS232 1
- A429 2
- RS232 2
- HSDB (GTX 345 only)
- RS232 3
- GILLHAM

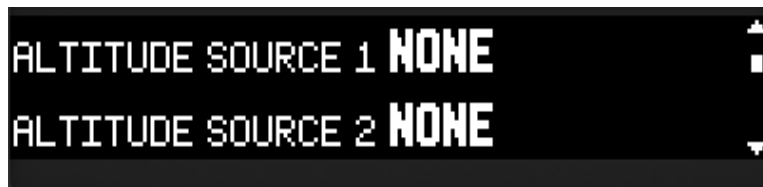

Figure 6-23 Altitude Source Page

GPS 1 SRC



NOTE

GTN 1, GTN 2, GIA 1, and GIA 2 are applicable to GTX 345 only.



NOTE

Lateral offset settings are determined from the perspective of the pilot. Right is positive and left is negative.

Sets the primary GPS source. Selections are:

- NONE
- INTRNL
- RS232 1
- RS232 2
- RS232 3
- RS232 4 (GTX 345 Only)
- A429 1
- A429 2
- GTN 1
- GTN 2
- GIA 1
- GIA 2

INTGRTY

Sets the integrity for the primary GPS. Choose the setting for the GPS. All certified Garmin GPS sources are 1E-7. Selections are:

- UNK
- IE-3
- IE-5
- IE-7
- Auto (Garmin GPS only)

LAT OFST

Sets the distance from the antenna and the centerline of the aircraft in meters. Selections are:

- UNK
- -6 mt
- -4 mt
- -2 mt
- 0 mt
- 2 mt
- 4 mt
- 6 mt

LON OFST

Sets the distance of the GPS antenna from the nose of the aircraft in meters. Selections are:

- UNK
- 2 mt to 60 mt in 2 mt increments

GPS 2 SRC

Sets the secondary GPS source. Selections are:

- NONE
- INTRNL
- RS232 1
- RS232 2
- RS232 3
- RS232 4
- A429 1
- A429 2
- GTN 1
- GTN 2
- GIA 1
- GIA 2

INTGRTY

Sets the integrity for the secondary GPS. Selections are:

- UNK
- IE-3
- IE-5
- IE-7
- AUTO

LAT OFST

Sets the secondary GPS lateral offset in meters. Selections are:

- UNK
- -6 mt
- -4 mt
- -2 mt
- 0 mt
- 2 mt
- 4 mt
- 6 mt

LON OFST

Sets the secondary GPS longitudinal offset. Selections are:

- UNK
- 2 mt to 60 mt in 2 mt increments



Figure 6-24 Source, Integrity, and Offset Page

INTERNAL ALT ENCODER INSTALLED

Select YES if a GAE module is connected to the backplate.

CEILING

Sets aircraft maximum altitude between 8,000 feet and 30,000 feet.

TEST POINTS

Sets the number of test points used to calibrate the GAE module. The range is 3 to 20. The maximum number of test points are limited by the aircraft ceiling setting.



Figure 6-25 Internal Alt Encoder Page

INTERNAL ALT ENCODER ADJUSTMENT

Sets the GAE module altitude to match the primary altitude display.



Figure 6-26 Internal Alt Encoder Adjustment Page

INTERNAL AHRS ORIENTATION (GTX 345 ONLY)

Sets connectors and vent to the orientation of the unit. Refer to figure B-10. Set the yaw angle of the unit relative to the centerline of aircraft. When setting the yaw angle, a positive angle indicates the GTX 345 is rotated clockwise from the longitudinal axis of the airplane (line from nose to tail). A negative angle indicates the GTX 345 is rotated counterclockwise. Refer to figure 6-27.

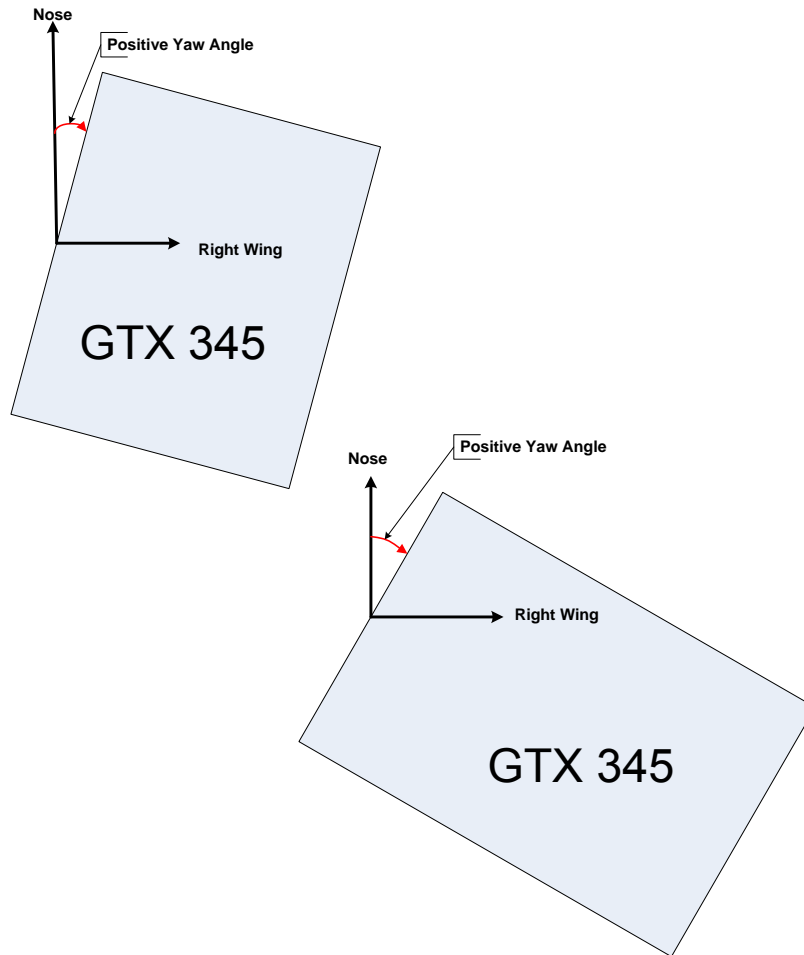

Figure 6-27 Setting the Yaw Angle



Figure 6-28 Internal AHRS Orientation Page

6.9 ADSB

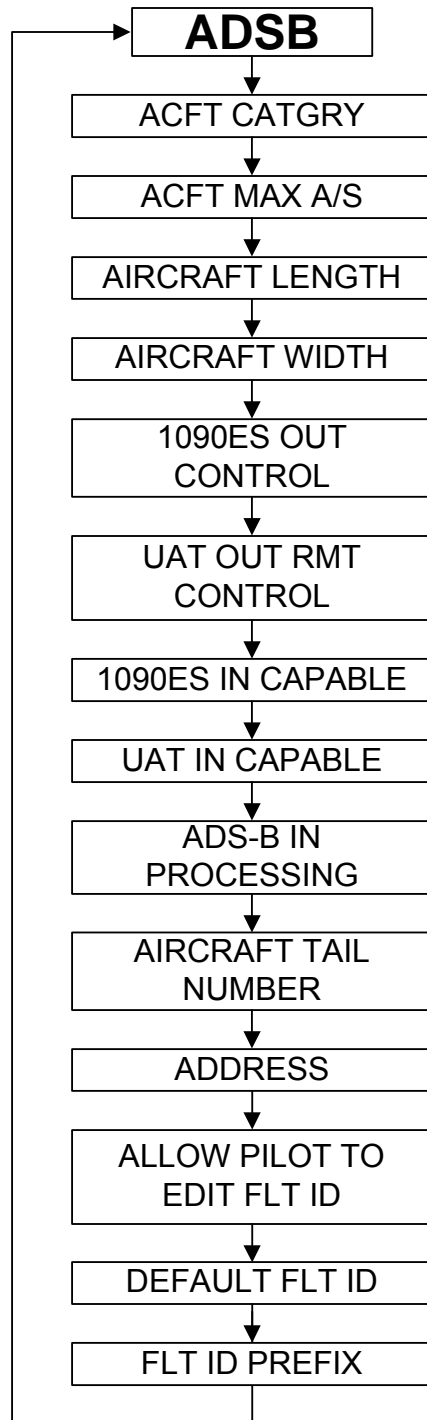

Figure 6-29 ADS-B Group



NOTE

Both 1090ES and UAT In settings can be set to YES when a portable ADS-B In receiver system, such as a GDL 39, is installed. It is not necessary to install a certified ADS-B In system.



NOTE

The GDL format must be configured to modify UAT OUT RMT CONTROL.

ACFT CATGRY

Sets the aircraft type. Select LIGHT for aircraft with a maximum gross weight less than 15,500 lbs. Selections are:

- UNKNOWN
- LIGHT
- SMALL
- HIGH PERFORMANCE
- ROTORCRAFT
- GLIDER
- LIGHTER-THAN-AIR
- ULTRALIGHT
- UAV

ACFT MAX A/S

Sets the maximum airspeed of the aircraft. Selections are:

- UNKNOWN
- <=75 kt
- <=150 kt
- <=300 kt
- <=600 kt
- <=1200 kt
- >1200 kt.



Figure 6-30 Aircraft Category and Max Airspeed Page

AIRCRAFT LENGTH

Sets aircraft length in meters.

- UNKNOWN
- <=35 mt
- <=65 mt
- >85 mt
- <=15 mt
- <=45 mt
- <= 75 mt
- <=25 mt
- <=55 mt
- <= 85 mt

AIRCRAFT WIDTH

Sets aircraft width in meters.

- Unknown
- <=34.0 mt
- <= 52.0 mt
- <=80.0 mt
- <=23.0 mt
- <=38.0 mt
- <=59.5 mt
- > 80 mt
- <=28.5 mt
- <=39.5 mt
- <=67.0 mt
- <=33.0 mt
- <= 45.0 mt
- <=72.5 mt



Figure 6-31 Aircraft Length and Width Page

1090ES OUT CONTROL

Sets 1090ES ADS-B transmission function. Selections are:

- Enabled
- Pilot Set
- Disabled

UAT OUT RMT CONTROL

Not available with GDL 88 software v3.33 or earlier.



Figure 6-32 1090ES Out Control and UAT Out Remote Control Page

1090ES IN CAPABLE

Select YES if the aircraft can receive 1090ES ADS-B messages.

UAT IN CAPABLE

Select YES if the aircraft can receive UAT ADS-B messages.



Figure 6-33 1090ES In Capable and UAT In Capable Page

ADS-B IN PROCESSING

Select ENABLED.



Figure 6-34 ADS-B In Processing Page

AIRCRAFT TAIL NUMBER

Set this to the registered aircraft tail number.

ADDRESS

Set the ICAO address to either octal or hex format. If the tail number is recognized as a US registered tail number, the ICAO address will be pre-filled by the GTX. It only needs to be compared to the aircraft registration records. Selections are:

- Octal
- Hex



Figure 6-35 Aircraft Tail Number and Address Page

ALLOW PILOT TO EDIT FLT ID

Select YES to let the pilot change the flight ID.

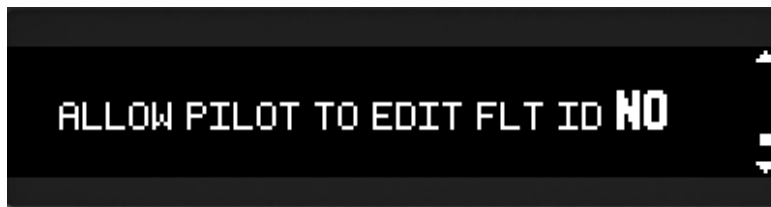

Figure 6-36 Allow Pilot to Edit Flight ID Page

DEFAULT FLT ID

Sets the default flight ID used in normal mode.

FLIGHT ID PREFIX

Sets the flight ID prefix with the carrier abbreviation. For example, Garmin AT is GAT.



Figure 6-37 Default Flight ID and Flight ID Prefix Page

6.10 Diagnostics

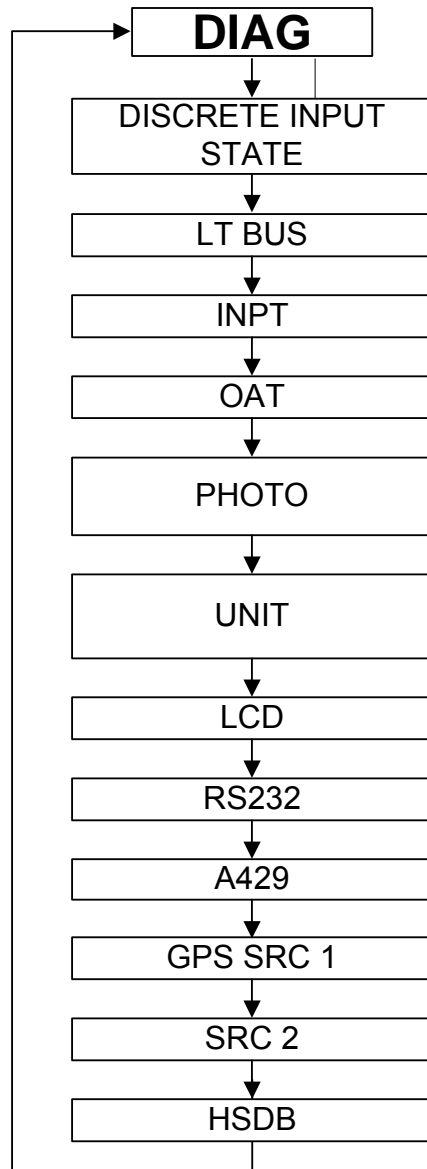

Figure 6-38 Diagnostics Group

The Diagnostics group shows information for troubleshooting purposes. Information includes:

- Discrete input state
- Lighting bus voltages
- Photocell voltages
- Outside air temperature
- Display temperature
- RS-232 channels
- ARINC 429 channels
- GPS Source 1 and GPS Source 2 status
- HSDB status (GTX 345)
- Gillham input state



Figure 6-39 Diagnostics Page

6.11 Remote Unit Configuration



CAUTION

Do not remove power from the unit when software upload is in progress.

The GTX 3X5 Installation Tool requires Windows 2000, XP, Vista, or Windows 7. There is no support at this time for Apple products. Use a PC or laptop and the GTX 3X5 Install Tool to configure units without a display. Selections are the same as for panel mount units. The GTX 3X5 Install Tool (P/N 006-A0271-01) is available at Garmin's [Dealer Resource Center](#). A USB-A plug to USB-B plug cable (not provided) is necessary.

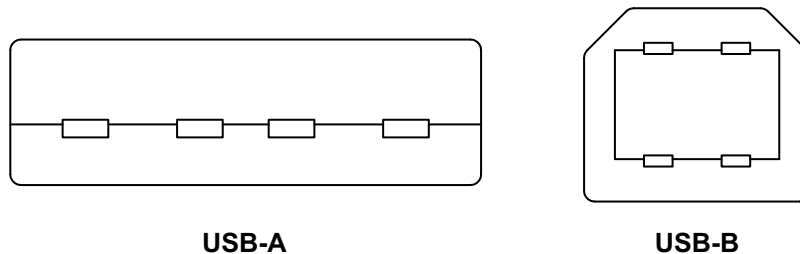

Figure 6-40 USB-A and USB-B Connectors

To use the GTX 3X5 Install Tool:

1. Remove power from the unit.
2. Connect the USB-A to USB-B cable between the computer and the USB-B receptacle installed in the aircraft wire harness.
3. Apply power to unit.
4. Launch the GTX 3X5 Install Tool.
5. Select the Configuration tab.
6. Select tabs to set parameters.

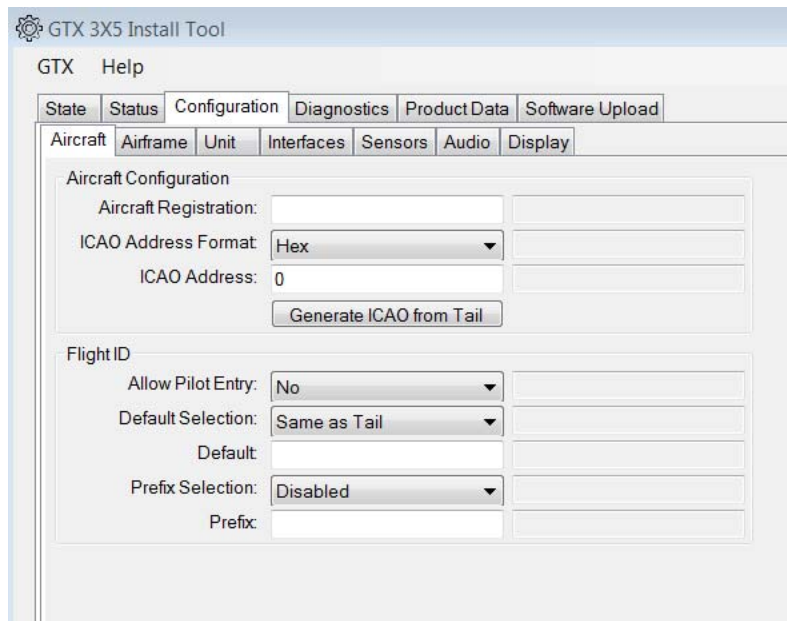

Figure 6-41 Aircraft Configuration Page

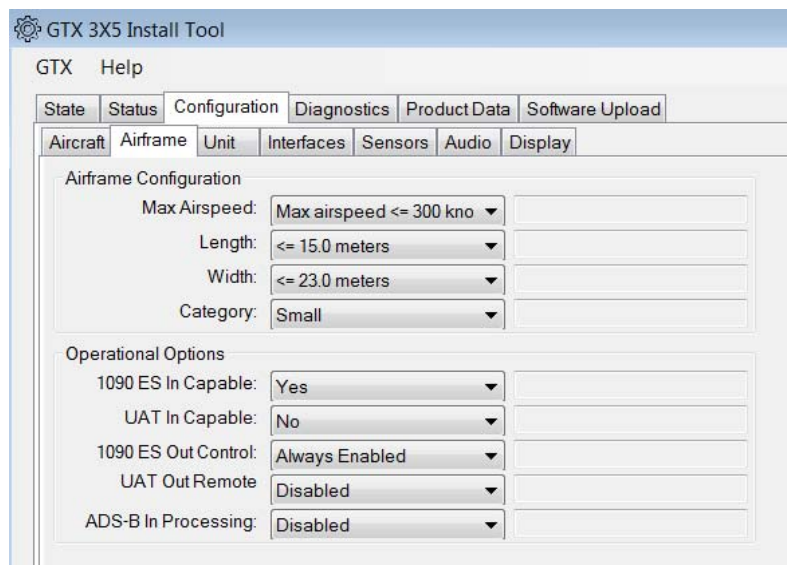

Figure 6-42 Airframe Configuration Page

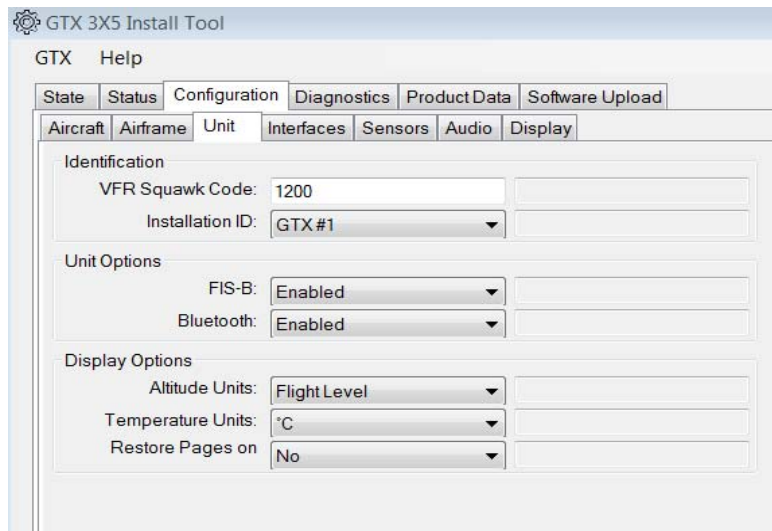

Figure 6-43 Unit Configuration Page

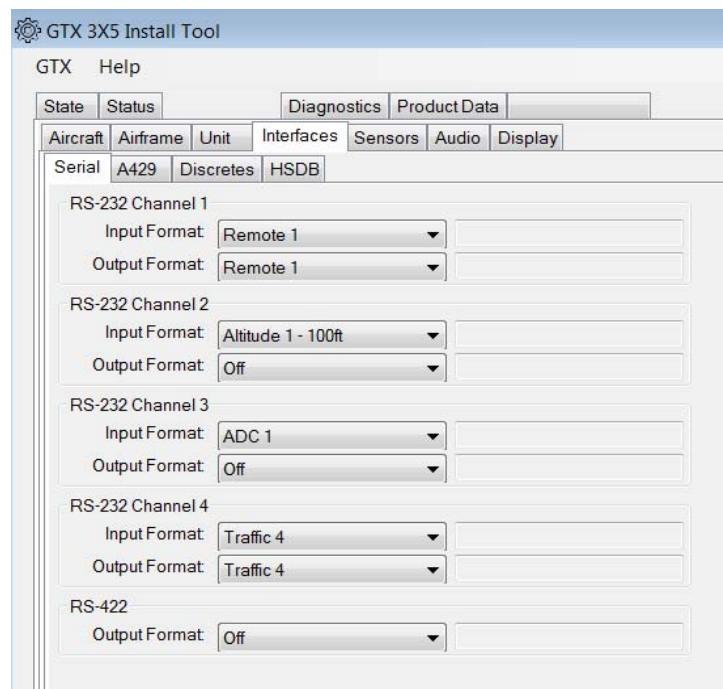

Figure 6-44 Interface Configuration Page - Serial

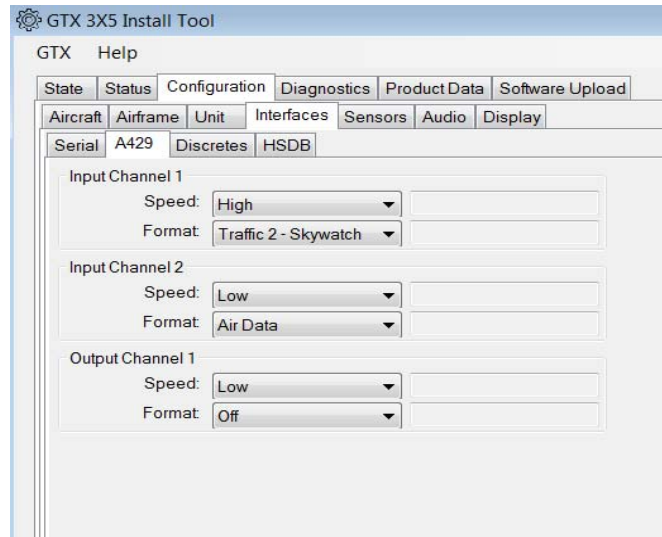

Figure 6-45 Interface Configuration Page - A429

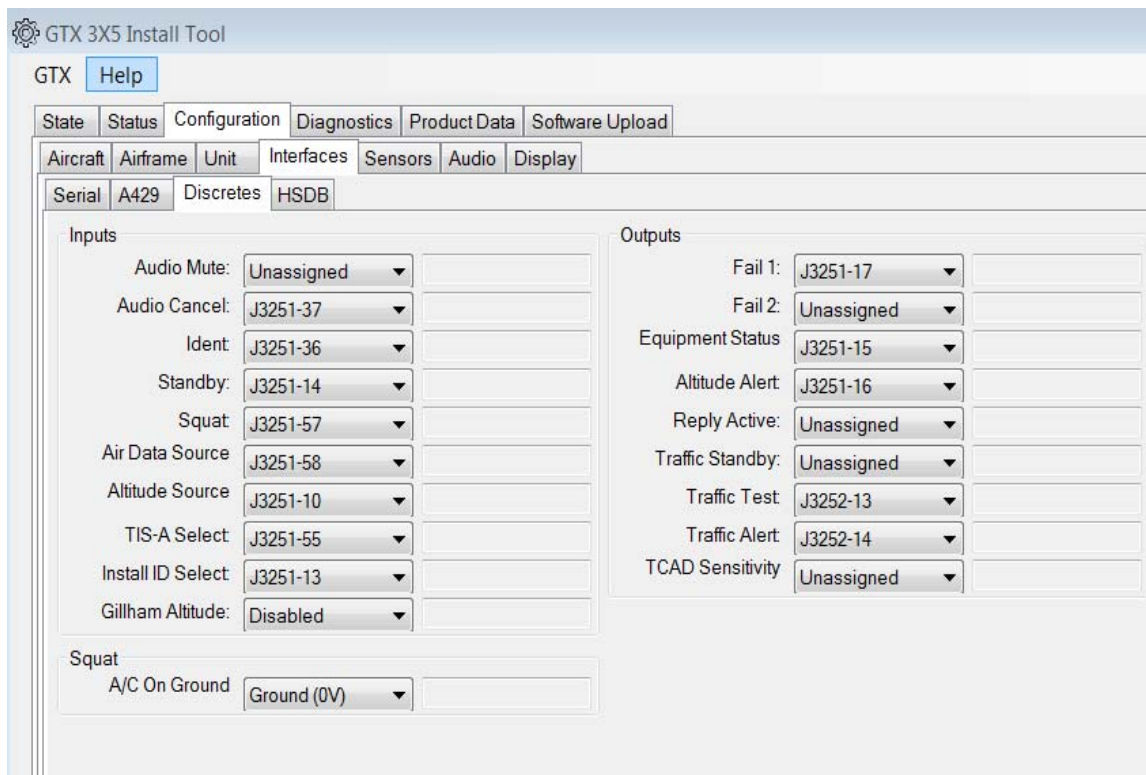

Figure 6-46 Interface Configuration Page - Discretes

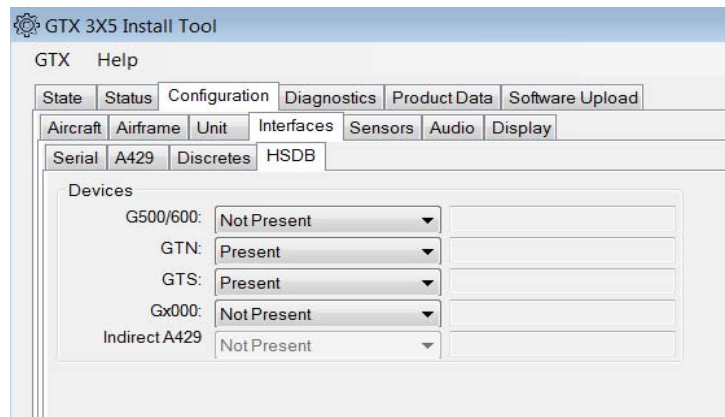

Figure 6-47 Interface Configuration Page - HSDB

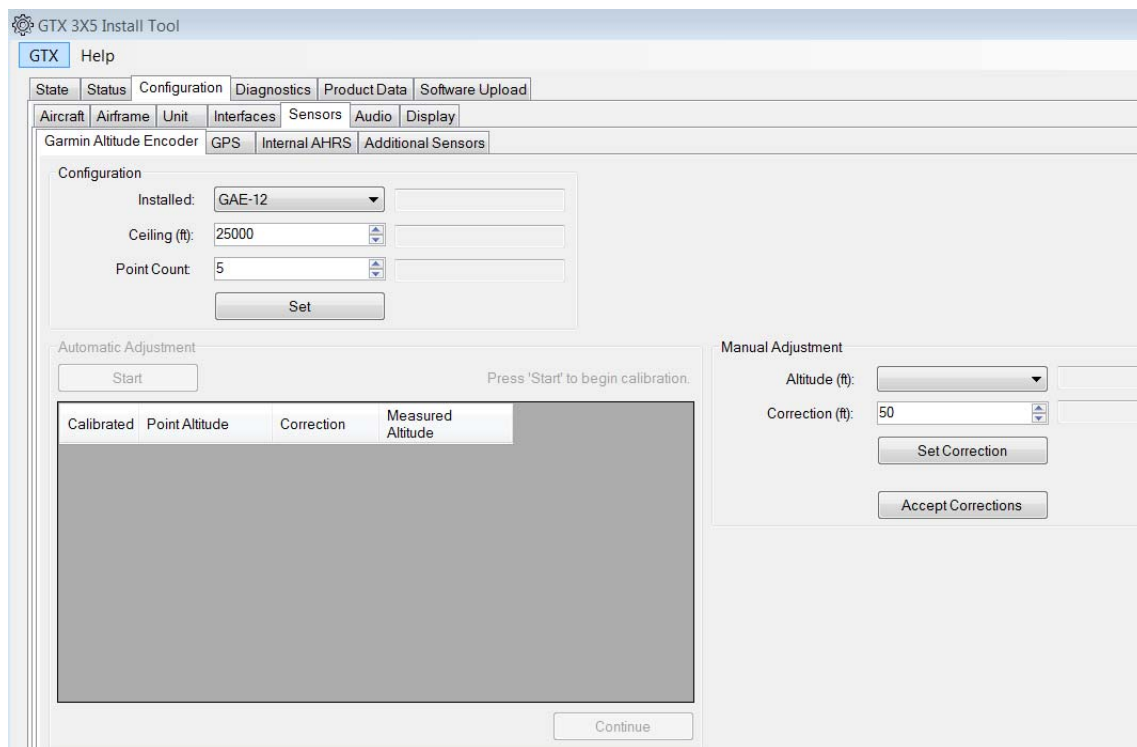

Figure 6-48 Sensors Configuration Page - GAE

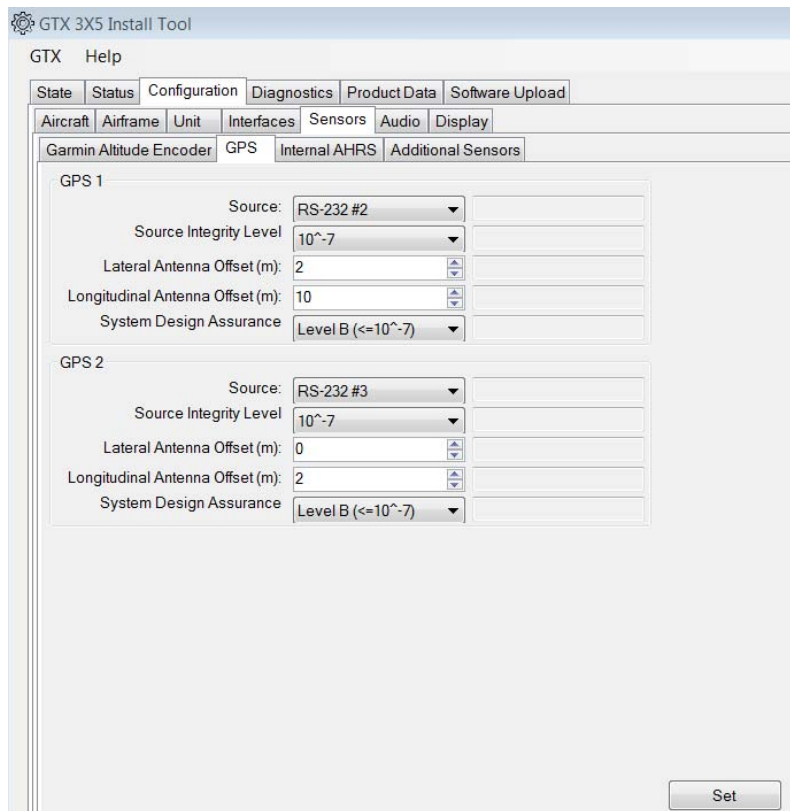

Figure 6-49 Sensors Configuration Page - GPS

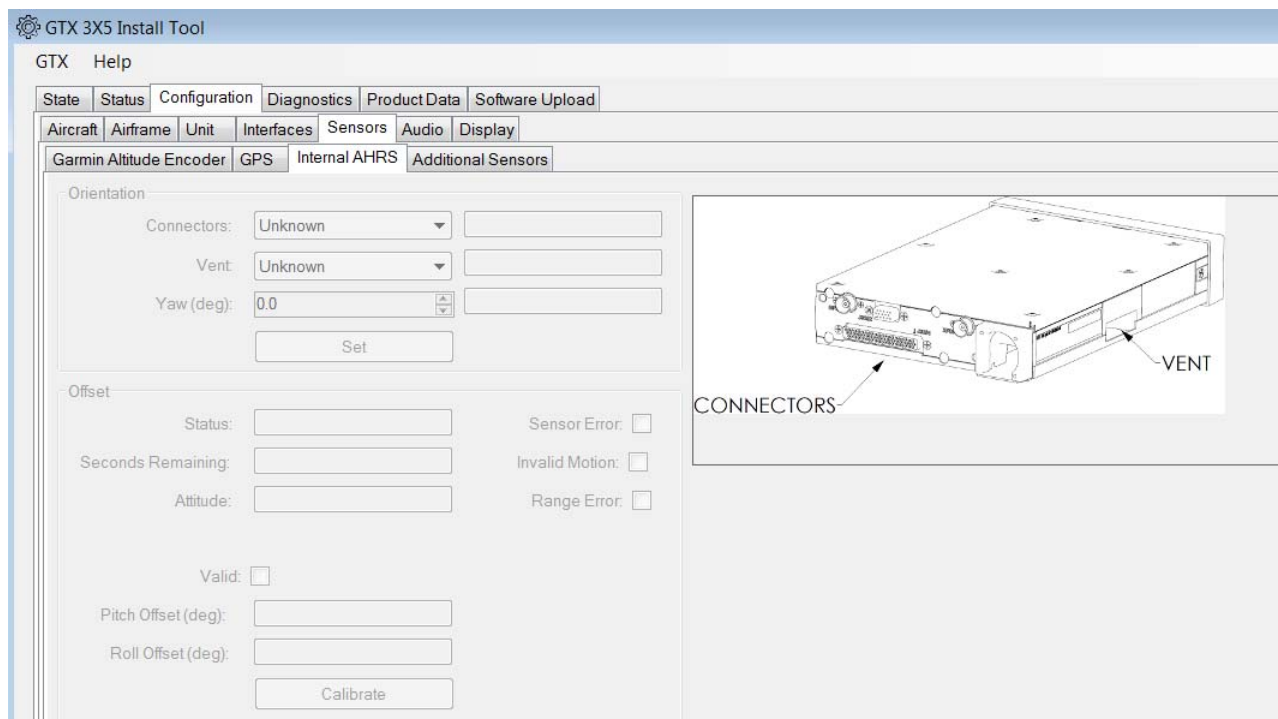

Figure 6-50 Sensors Configuration Page - Internal AHRS

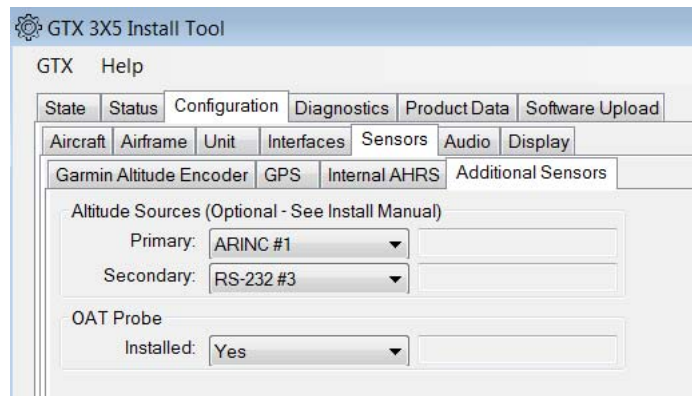

Figure 6-51 Sensors Configuration Page - Additional Sensors

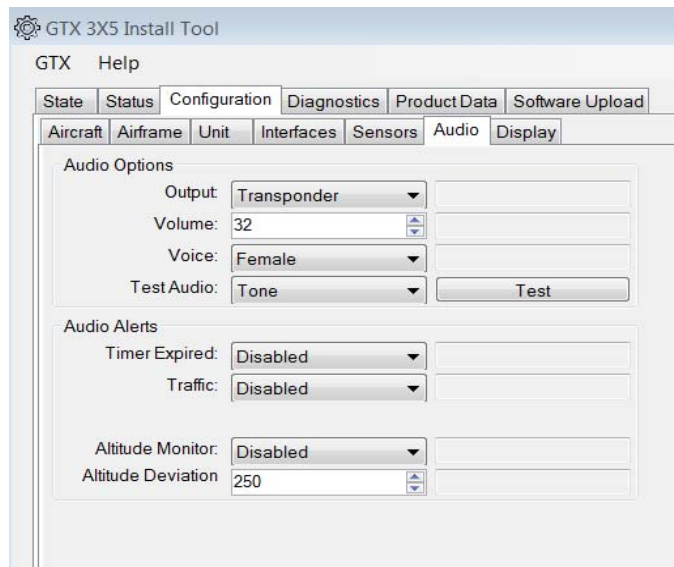

Figure 6-52 Audio Configuration Page

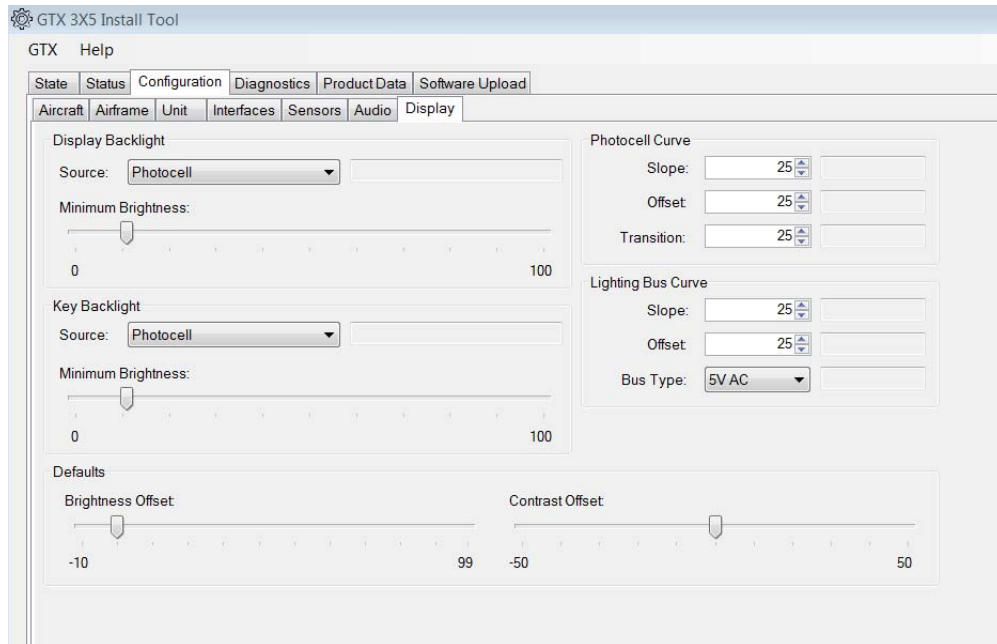

Figure 6-53 Display Configuration Page - Panel Mount Units Only

6.12 Ground Check - GPS Reception Check



NOTE

If an external GPS is in use, GPS reception checks are not necessary.

The GPS check in this section is applicable to GTX 335 and GTX 345 units with an optional internal GPS receiver.

1. Make sure the LAT/LON on the ADS-B Out page matches with a known reference.
2. Select 121.150 MHz on the COM transceiver to be tested.
3. Transmit for a period of 35 seconds.
4. Make sure the LAT/LON continues to match the known reference.
5. Repeat steps 3 and 4 for the following frequencies.
 - 121.15 MHz • 121.22 MHz • 131.22 MHz • 131.30 MHz
 - 121.17 MHz • 121.25 MHz • 131.25 MHz • 131.32 MHz
 - 121.20 MHz • 131.20 MHz • 131.27 MHz • 131.35 MHz
6. For VHF radios that include 8.33 kHz channel spacing, include the following frequencies in addition to those in step 5.
 - 121.185 MHz • 130.285 MHz
 - 121.190 MHz • 131.290 MHz
7. Repeat steps 2 through 6 for all remaining COM transceivers in the aircraft.
8. Turn on the TCAS system and make sure the GPS position remains valid if the aircraft is TCAS equipped.
9. Use the SATCOM system to make sure the GPS position remains valid if the aircraft is SATCOM equipped.

6.13 Software Installation Procedure



CAUTION

Do not turn off the unit until “Update Complete” is shown next to all selected items. Failure to do so could result in equipment damage.

Use the GTX 3X5 Install Tool through the USB port to install software on the unit.

1. Download and launch the latest GTX 3X5/3X5R software from the [Dealer Resource Center](#) on Garmin’s website.
2. Under “Step 1 - Select a File,” select the **Browse** key and locate the Boot Block software file containing the GTX 3X5/3X5R software previously loaded.
3. Under “Step 2 - Upload Options,” select the options to be updated.
4. Under “Step 3 - Start Upload,” select the **Upload** key.
5. Wait for the upload to complete. Individual files will be marked as complete as they are installed.
6. Under “Step 1 - Select a File,” select the **Browse** key and locate the Main System software file containing the GTX 3X5/3X5R software previously downloaded.
7. Under “Step 2 - Upload Options,” select the remaining options to be updated.
8. Under “Step 3 - Start Upload,” select the **Upload** key.
9. Wait for the upload to complete. Individual files will be marked as complete as they are installed.
10. After successful completion of the update, make sure that the correct software versions and part numbers show on the Transponder page under the Product Data group. If any software items did not load, select those items and attempt to upload again.

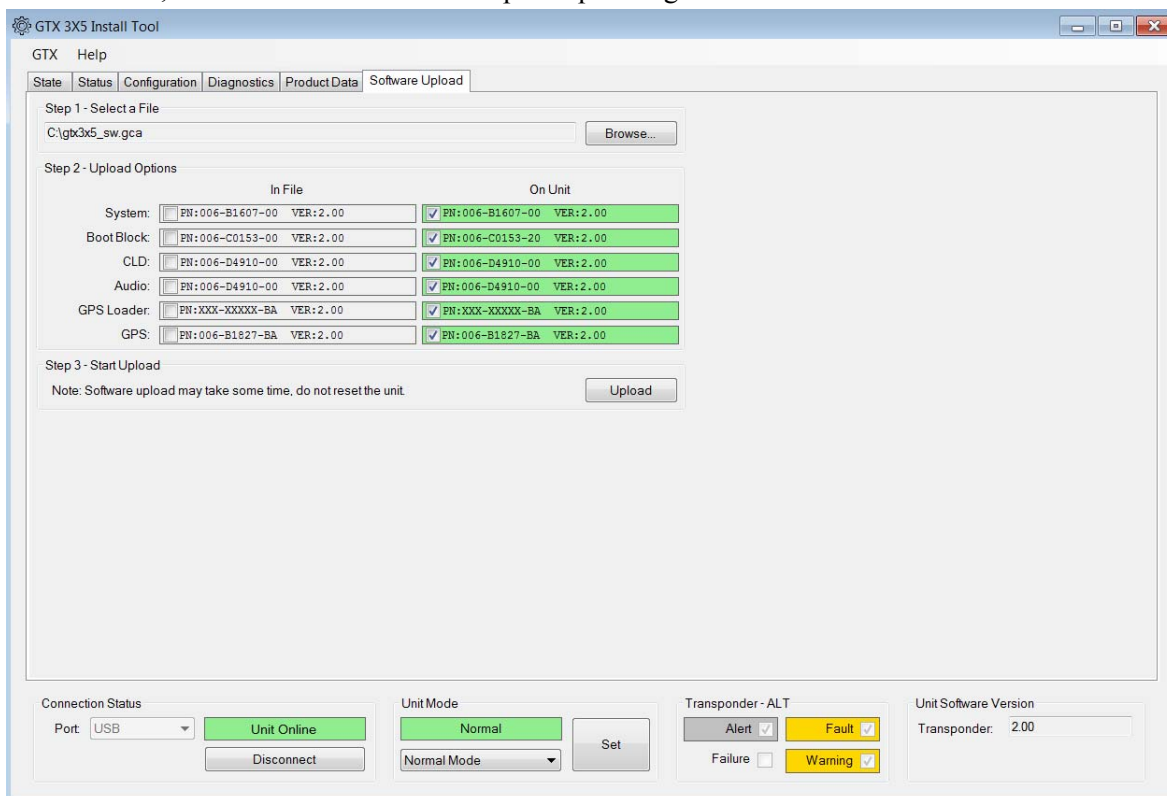

Figure 6-54 Software Upload Page

7 CONTINUED AIRWORTHINESS

Other than for regulatory periodic functional checks, maintenance of the GTX 3X5 is “on condition” only. Periodic maintenance of the GTX 3X5 is not required.

APPENDIX A DATA FORMATS

A.1	RS-232 Air Data Input Format	A-1
A.1.1	Electrical Interface	A-1
A.1.2	Altitude Format 1 Sentence	A-1
A.1.3	Altitude Format 3 Sentence	A-1
A.1.4	Airdata Format 1 Sentence	A-2

A.1 RS-232 Air Data Input Format

A.1.1 Electrical Interface

The input signals are compatible with RS-232C. Data input at 9600 baud with a word length of 8 bits, one stop bit, and no parity. One message is received per second.

A.1.2 Altitude Format 1 Sentence

The GTX 3X5 is capable of receiving the following 10-byte message from the altitude serializer.

ALT <sp>12345<CR>

Where:

ALT	ASCII characters
<sp>	space (0x20)
12345	altitude in feet
<CR>	carriage return (0x0D)

A.1.3 Altitude Format 3 Sentence

The GTX 3X5 is capable of receiving the following 17-byte message from GAE modules, altitude serializers, and altitude converters.

RMS<sp><+/->12345T<+/->12ul<CR>

Where:

RMS	ASCII characters
<sp>	space (0x20)
<+/->	sign indicator (0x2B[+] or 0x2D[-])
12345	altitude in feet
T	ASCII character
<+/->	sign indicator
12	sensor temperature
ul	checksum of bytes 1 through 14 in hex ASCII (i.e., FA)
<CR>	carriage return (0x0D)



NOTE

Checksum is calculated by adding each byte in the message (1 through 14).

A.1.4 Airdata Format 1 Sentence

The GTX 3X5 is capable of receiving the following message strings from the air data computer.

SHADIN Z FORMAT

```

<STX>
ZA012<CR><LF>    ZA (ASCII characters); 012 represents indicated air speed (knots)
ZB345<CR><LF>    ZB (ASCII characters); 345 represents true air speed (knots)
ZC678<CR><LF>    ZC (ASCII characters); 678 represents mach speed (thousandths)
ZD<+/->9012<CR><LF> ZD (ASCII characters); sign; 9012 represents pressure altitude (tens of feet)
ZE<+/->3456<CR><LF> ZE (ASCII characters); sign; 3456 represents density altitude (tens of feet)
ZF<+/->78<CR><LF>  ZF (ASCII characters); sign; 78 represents outside air temperature (Celsius)
ZG<+/->90<CR><LF>  ZG (ASCII characters); sign; 90 represents true air temperature (Celsius)
ZL234<CR><LF>    ZL (ASCII characters); 234 represents heading (degrees from north)
ZQ345<CR><LF>    ZQ (ASCII characters); 345 represents error log/reason indicator
ZR678<CR><LF>    ZR (ASCII characters); 678 represents checksum
<ETX>
  
```

Where:

```

<STX>    start-transmit character (0x02)
<CR>    carriage-return character (0x0D)
<LF>    line-feed character (0x0A)
<+/->    sign indicator (0x2B[+] or 0x2D[-])
<ETX>    end-transmit character (0x03)
  
```



NOTE

Checksum is calculated by adding each byte in the message (including all characters from <STX> up to and including the error log/reason indicator), such that carries are discarded to give a one byte result. The ASCII-coded decimal representation of that byte is given, ranging from 0 (0x30, 0x30, 0x30) to 255 (0x32, 0x35, 0x35).

SHADIN G FORMAT

<STX>	
GA012<CR><LF>	GA (ASCII characters); 012 represents indicated air speed (knots)
GB345<CR><LF>	GB (ASCII characters); 345 represents true air speed (knots)
GC678<CR><LF>	GC (ASCII characters); 678 represents Mach speed (thousandths)
GD<+/->9012<CR><LF>	GD (ASCII characters); sign; 9012 represents pressure altitude (tens of feet)
GE<+/->3456<CR><LF>	GE (ASCII characters); sign; 3456 represents density altitude (tens of feet)
GF<+/->78<CR><LF>	GF (ASCII characters); sign; 78 represents outside air temperature (Celsius)
GG<+/->90<CR><LF>	GG (ASCII characters); sign; 90 represents true air temperature (Celsius)
GK<+/->901<CR><LF>	GK (ASCII characters); sign; 901 represents vertical speed (tens of ft/minute)
GL234<CR><LF>	GL (ASCII characters); 234 represents heading (degrees from north)
GP89012<CR><LF>	GP (ASCII characters); 89012 represents fuel used, left (or Single) (tenths gallons)
GR6789.0<CR><LF>	GR (ASCII characters); 6789.0 represents fuel remaining (gallons) [1]
Ga<+/->1234<CR><LF>	Ga (ASCII characters); sign; 12.34 represents barometric corrected altitude (tens of feet)
Gb56.78<CR><LF>	Gb (ASCII characters); 56.78 represents current barometric pressure setting (inches Hg)
G*901<CR><LF>	G* (ASCII characters); 901 represents checksum

<ETX>

Where:

<STX>	start-transmit character (0x02)
<CR>	carriage-return character (0x0D)
<LF>	line-feed character (0x0A)
<+/->	sign indicator (0x2B[+] or 0x2D[-])
<ETX>	end-transmit character (0x03)

[1] Not available from Airdata Computer



NOTE

Checksum is calculated by adding each byte in the message (including all characters from <STX> up to and including the error log/reason indicator), such that carries are discarded to give a one byte result. The ASCII-coded decimal representation of that byte is given, ranging from 0 (0x30, 0x30, 0x30) to 255 (0x32, 0x35, 0x35).

SHADIN S FORMAT

<STX>	
SA012<CR><LF>	SA (ASCII characters); 012 represents indicated air speed (knots)
SB345<CR><LF>	SB (ASCII characters); 345 represents true air speed (knots)
SC678<CR><LF>	SC (ASCII characters); 678 represents Mach speed (thousandths)
SD<+/->9012<CR><LF>	SD (ASCII characters); sign; 9012 represents pressure altitude (tens of feet)
SE<+/->3456<CR><LF>	SE (ASCII characters); sign; 3456 represents density altitude (tens of feet)
SF<+/->78<CR><LF>	SF (ASCII characters); sign; 78 represents outside air temperature (Celsius)
SG<+/->90<CR><LF>	SG (ASCII characters); sign; 90 represents true air temperature (Celsius)
SK<+/->901<CR><LF>	SK (ASCII characters); sign; 901 represents vertical speed (tens of ft/minute)
SL234<CR><LF>	SL (ASCII characters); 234 represents heading (degrees from north)
Sa<+/->1234<CR><LF>	Sa (ASCII character); sign; 1234 represents barometric corrected altitude (tens of feet)
Sb56.78<CR><LF>	Sb (ASCII character); 56.78 represents current barometric pressure setting (inches Hg)
S*901<CR><LF>	S* (ASCII character); 901 represents checksum

<ETX>

Where:

<STX>	start-transmit character (0x02)
<CR>	carriage-return character (0x0D)
<LF>	line-feed character (0x0A)
<+/->	sign indicator (0x2B[+] or 0x2D[-])
<ETX>	end-transmit character (0x03)



NOTE

Checksum is calculated by adding each byte in the message (including all characters from <STX> up to and including the error log/reason indicator), such that carries are discarded to give a one byte result. The ASCII-coded decimal representation of that byte is given, ranging from 0 (0x30, 0x30, 0x30) to 255 (0x32, 0x35, 0x35).

APPENDIX B GTX 3X5 MECHANICAL DRAWINGS

Figure B-1	GTX 345 GPS Panel Mount Assembly Shown	B-2
Figure B-2	GTX 345 GPS Panel Mount Dimensions and CG Shown	B-3
Figure B-3	GTX 345R GPS Standard Remote Mount Assembly Shown	B-4
Figure B-4	GTX 345R GPS Standard Remote Mount Dimensions and CG Shown.....	B-5
Figure B-5	GTX 3X5 Vertical Remote Mount.....	B-6
Figure B-6	GTX 3X5 Vertical Remote Mount Dimensions and CG	B-7
Figure B-7	G1000 Mount Rack Assembly with GTX 345R GPS Shown	B-8
Figure B-8	G1000 Mounting Rack Dimensions and CG with GTX 345R GPS Shown.....	B-9
Figure B-9	GTX 3X5 Panel Cutout Detail	B-10
Figure B-10	GTX 3X5 Connector and Vent Locations.....	B-11
Figure B-11	Optional Garmin Altitude Encoder	B-11

STANDARD KIT	UNIT PN	UNIT DESCRIPTION	CONNECTOR KIT	CONFIG MODULE	RACK	Back Plate Assy	Mount Type	Dim A - inch (mm)	Dim B - inch (mm)	Dim C - inch (mm)
010-01083-01	011-02974-00	Sub-Assy,GTX325,BIK	011-02977-00	011-00979-03	115-01771-01	011-02976-00	Panel	4.5 (114)	3.2 (81)	0.8 (20)
010-01214-01	011-03300-00	Sub-Assy,GTX335	011-02977-00	011-00979-03	115-01771-01	011-02976-00	Panel	4.5 (114)	3.2 (81)	0.8 (20)
010-01214-21	011-03300-20	Sub-Assy,GTX335, NV	011-02977-00	011-00979-03	115-01771-01	011-02976-00	Panel	4.5 (114)	3.2 (81)	0.8 (20)
010-01214-41	011-03300-40	Sub-Assy,GTX335,GPS	011-02977-00	011-00979-03	115-01771-01	011-02976-01	Panel	4.5 (114)	3.2 (81)	0.8 (20)
010-01216-00	011-03302-00	Sub-Assy,GTX345	011-02977-01	011-00979-03	115-01771-01	011-02976-00	Panel	4.7 (119)	3.0 (76)	0.8 (20)
010-01216-40	011-03302-40	Sub-Assy,GTX345, GPS	011-02977-01	011-00979-03	115-01771-01	011-02976-01	Panel	4.6 (117)	3.0 (76)	0.8 (20)

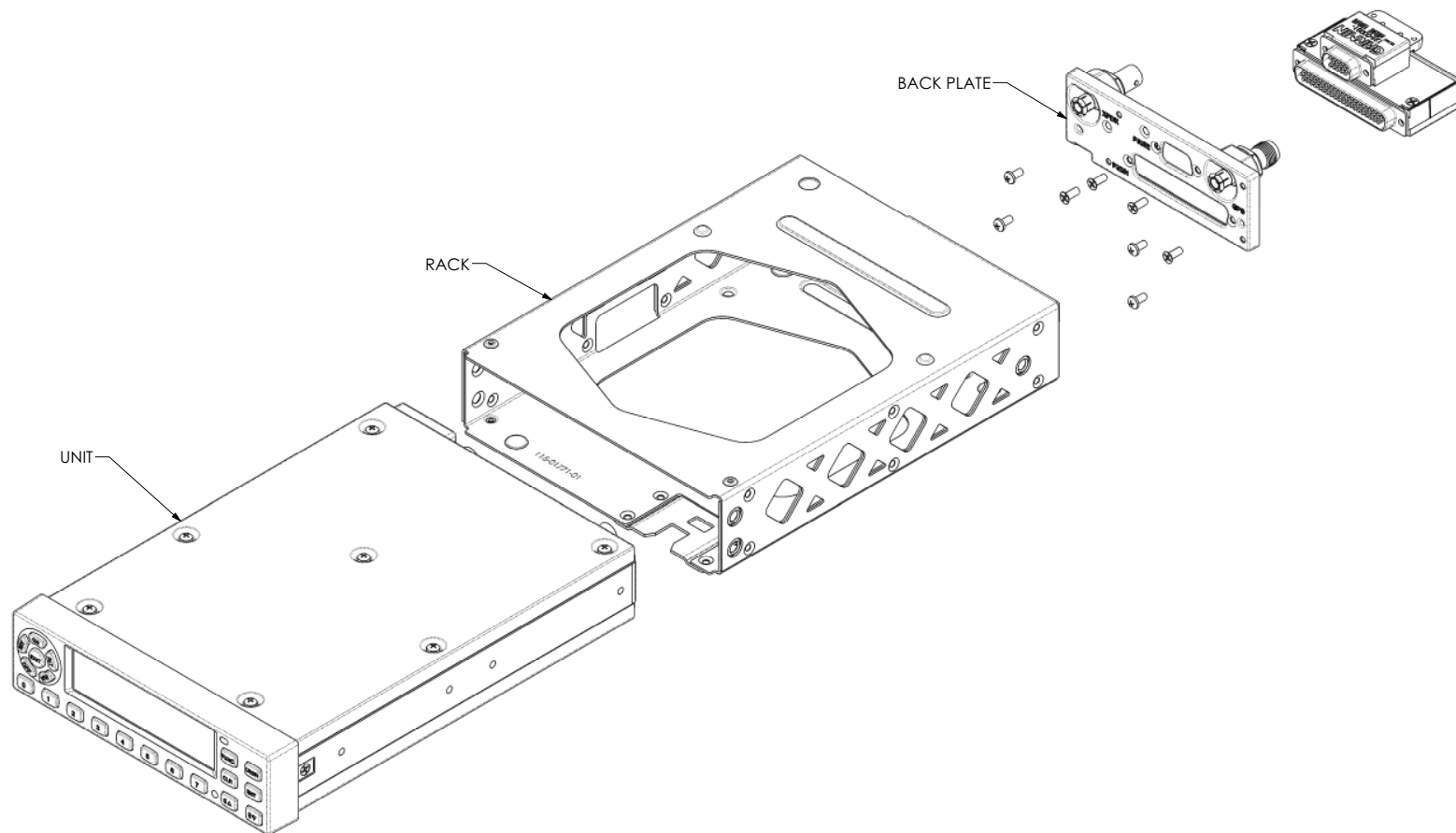

Figure B-1 GTX 345 GPS Panel Mount Assembly Shown

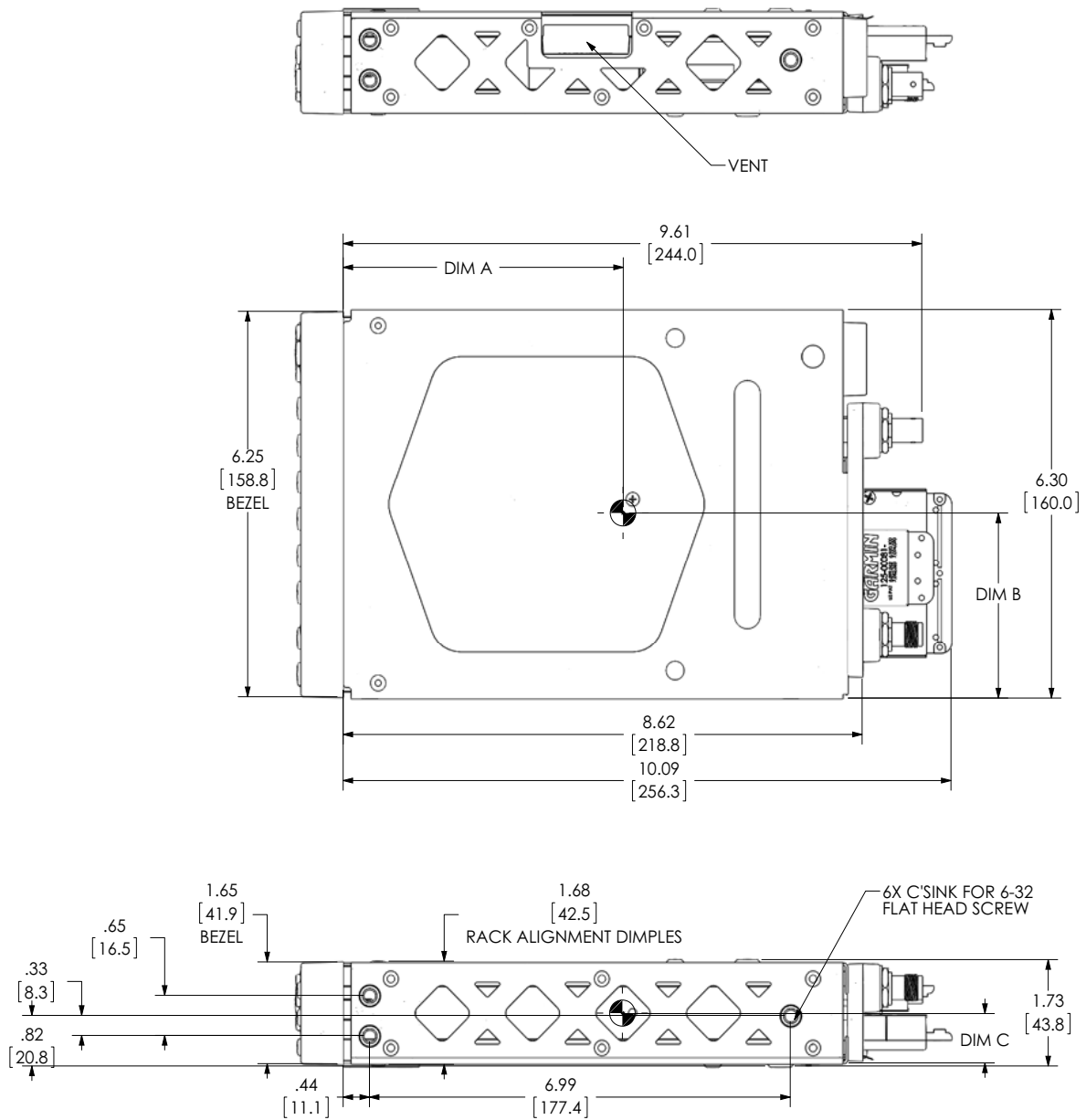

Figure B-2 GTX 345 GPS Panel Mount Dimensions and CG Shown

STANDARD KIT	UNIT PN	UNIT DESC	CONNECTOR KIT	CONFIG MODULE	RACK	Back Plate Assy	Mount Type	Dim A inch (mm)	Dim B inch (mm)	Dim C inch (mm)
010-01215-01	011-03301-00	Sub-Assy,GTX335R	011-02977-00	011-00979-03	115-01771-00	011-02976-00	Remote	4.8 (120)	3.3 (84)	0.8 (20)
010-01215-40	011-03301-40	Sub-Assy,GTX335R, GPS	011-02977-00	011-00979-03	115-01771-00	011-02976-01	Remote	4.9 (124)	3.2 (81)	0.8 (20)
010-01217-00	011-03303-00	Sub-Assy,GTX345R	011-02977-01	011-00979-03	115-01771-00	011-02976-00	Remote	5.0 (127)	3.0 (76)	0.8 (20)
010-01217-40	011-03303-40	Sub-Assy,GTX345R, GPS	011-02977-01	011-00979-03	115-01771-00	011-02976-01	Remote	5.0 (127)	3.1 (79)	0.8 (20)

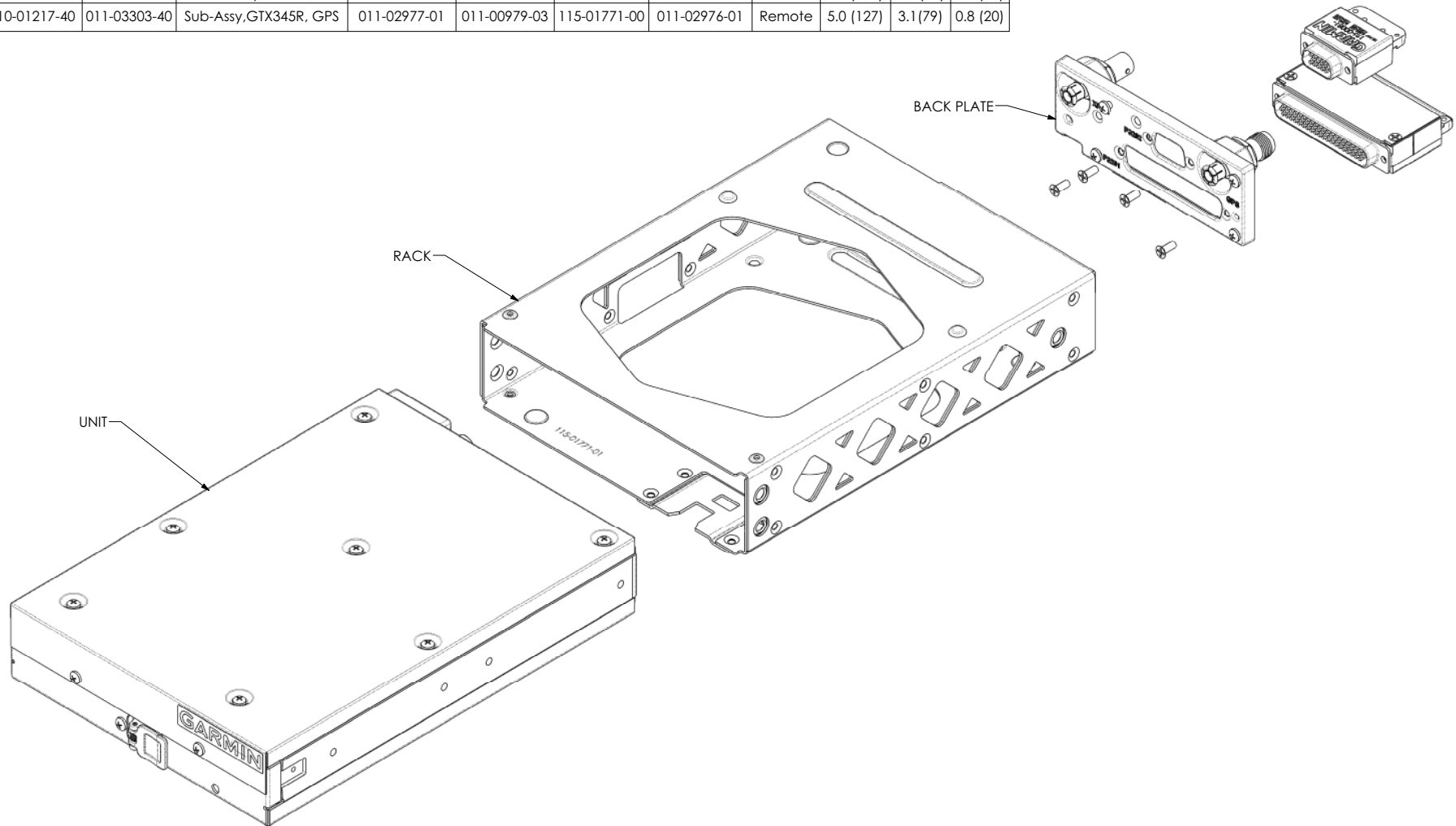

Figure B-3 GTX 345R GPS Standard Remote Mount Assembly Shown

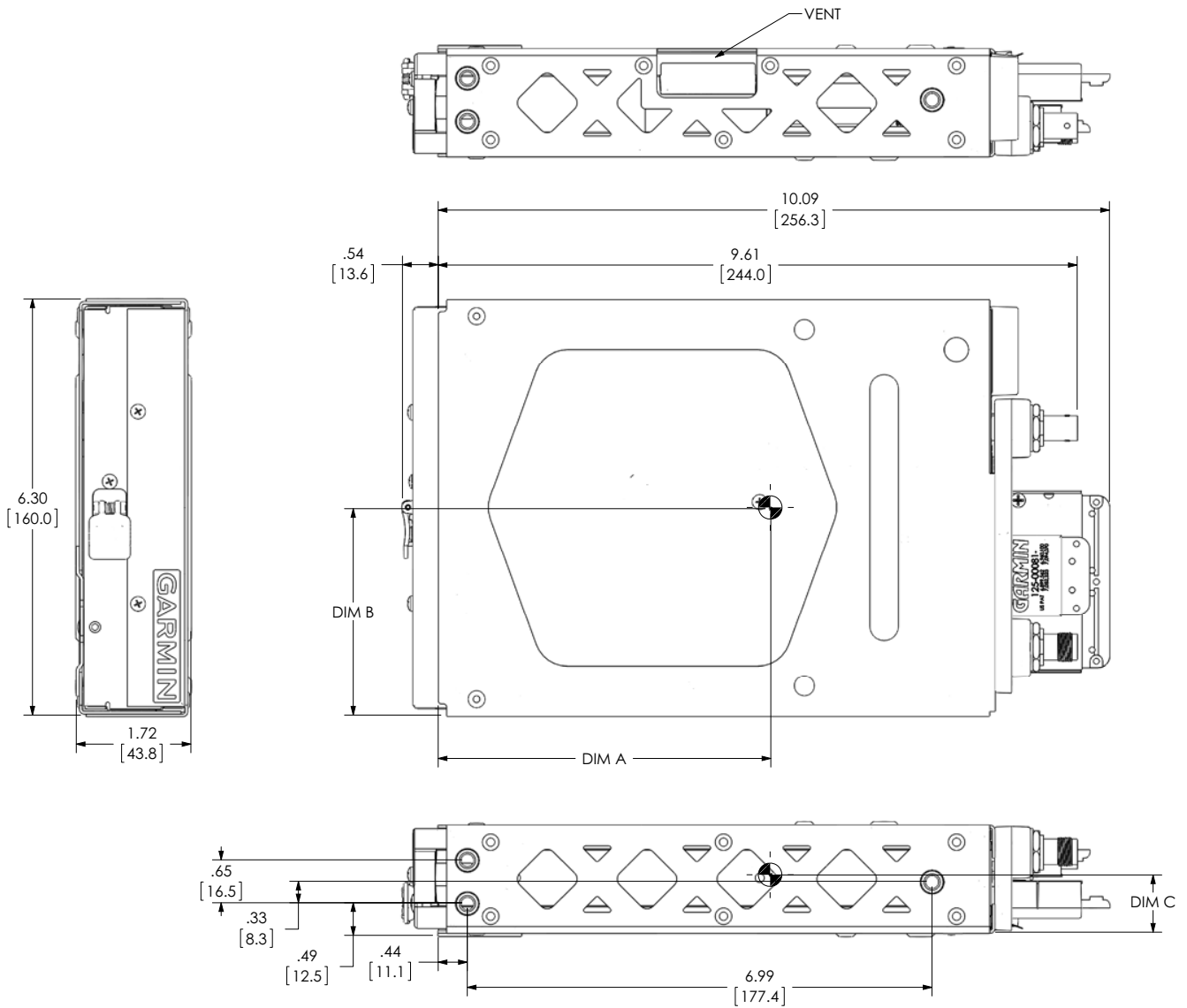
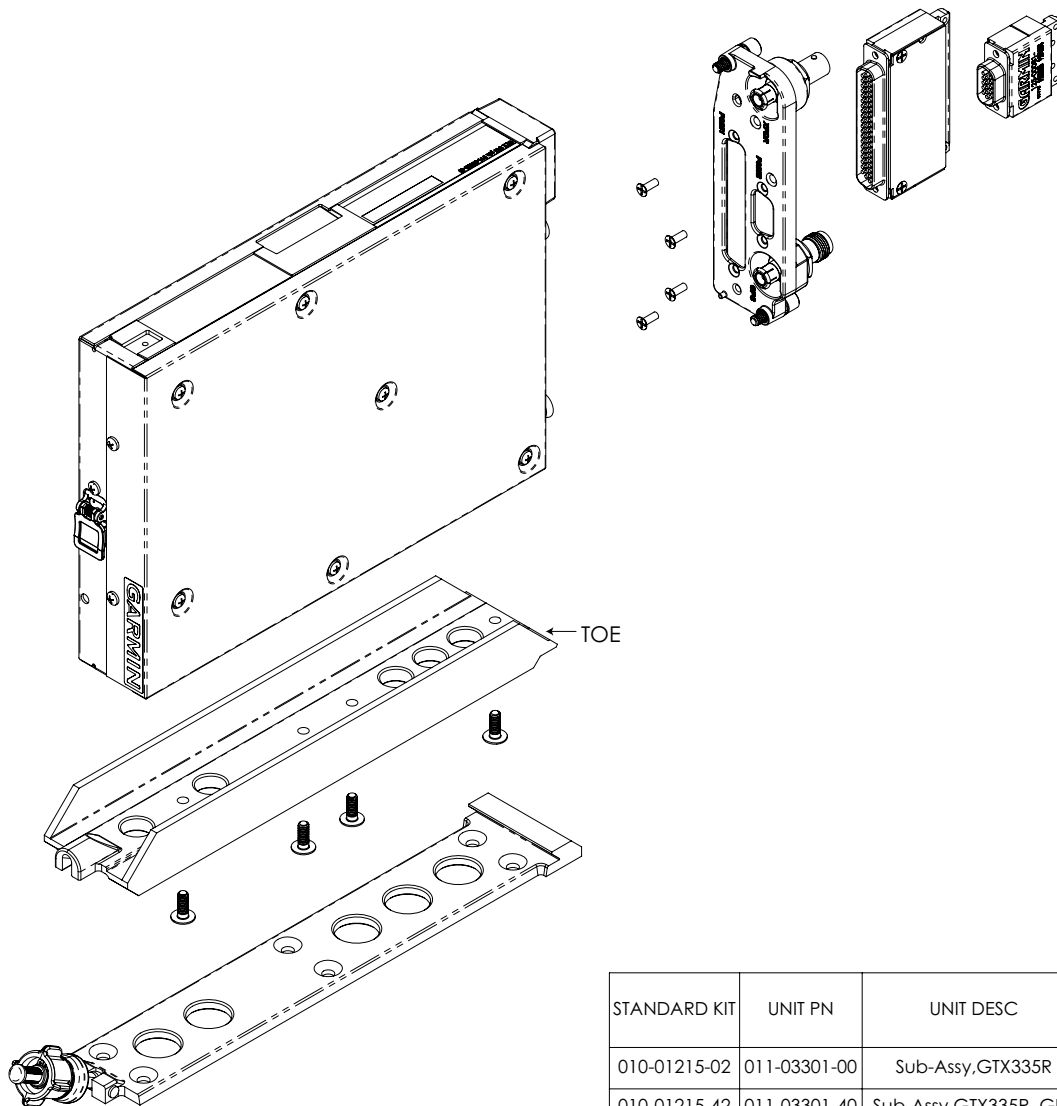

Figure B-4 GTX 345R GPS Standard Remote Mount Dimensions and CG Shown



STANDARD KIT	UNIT PN	UNIT DESC	CONNECTOR KIT	CONFIG MODULE	RACK	Back Plate Assy	Mount Type	Dim A inch (mm)	Dim B inch (mm)	Dim C inch (mm)
010-01215-02	011-03301-00	Sub-Assy,GTX335R	011-02977-00	011-00979-03	011-03762-00	011-02976-10	Remote	5.5 (140)	2.7 (69)	1.0 (25)
010-01215-42	011-03301-40	Sub-Assy,GTX335R, GPS	011-02977-00	011-00979-03	011-03762-00	011-02976-11	Remote	5.5 (140)	2.8 (71)	0.9 (23)
010-01217-02	011-03303-00	Sub-Assy,GTX345R	011-02977-01	011-00979-03	011-03762-00	011-02976-10	Remote	5.6 (142)	2.7 (69)	0.9 (23)
010-01217-42	011-03303-40	Sub-Assy,GTX345R, GPS	011-02977-01	011-00979-03	011-03762-00	011-02976-11	Remote	5.6 (142)	2.7 (69)	0.9 (23)

Figure B-5 GTX 3X5 Vertical Remote Mount

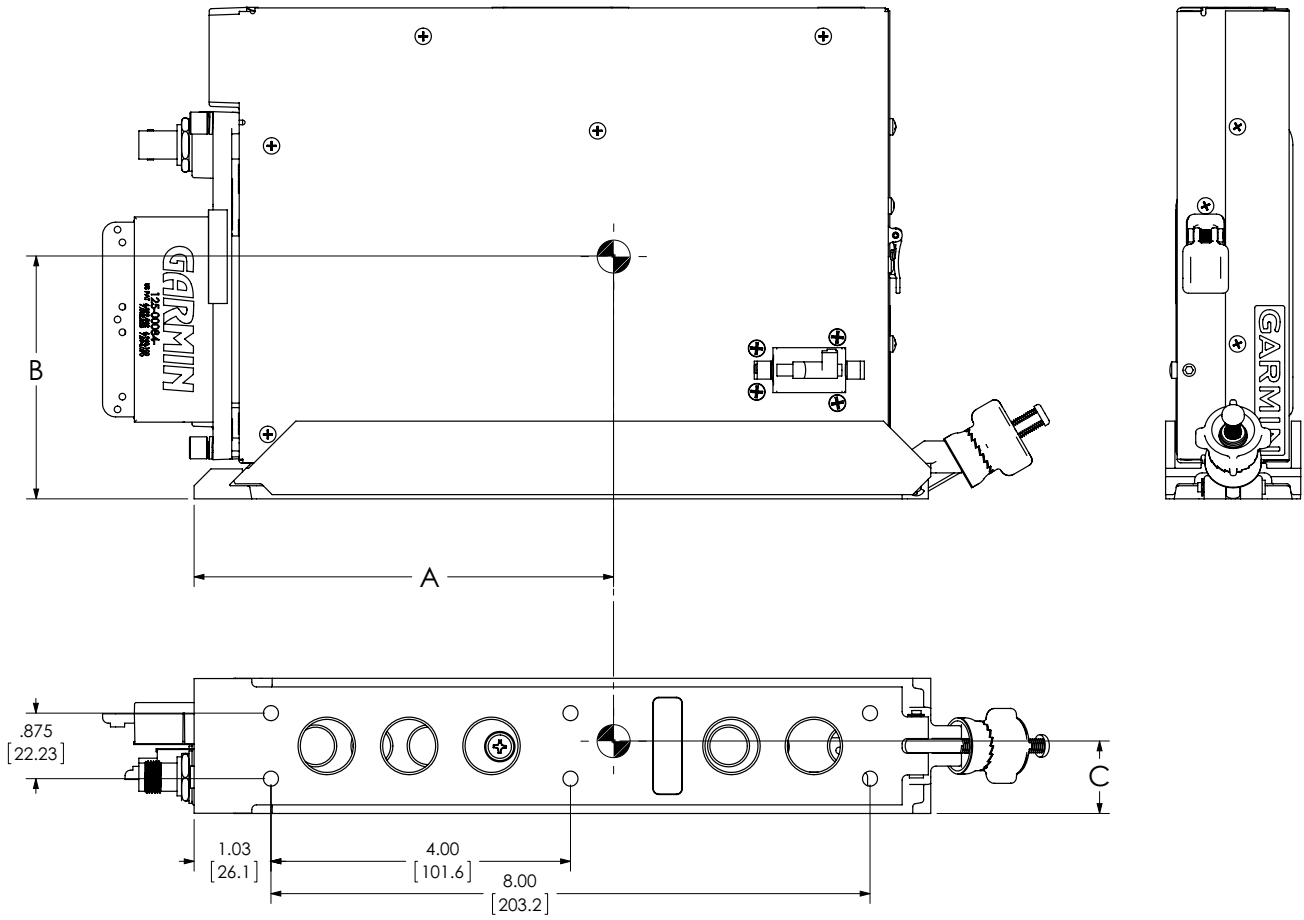

Figure B-6 GTX 3X5 Vertical Remote Mount Dimensions and CG

STANDARD KIT	UNIT PN	UNIT DESC	CONNECTOR KIT	CONFIG MODULE	RACK	Back Plate Assy	Mount Type	Dim A inch (mm)	Dim B inch (mm)	Dim C inch (mm)
G1000 mount	011-03301-00	Sub-Assy, GTX335R	011-02977-00	011-00979-03	115-02250-00	011-02976-00	G1000	5.3 (135)	3.2 (81)	0.7 (18)
G1000 mount	011-03301-40	Sub-Assy, GTX335R, GPS	011-02977-00	011-00979-03	115-02250-00	011-02976-01	G1000	5.3 (135)	3.2 (81)	0.8 (20)
G1000 mount	011-03303-00	Sub-Assy, GTX345R	011-02977-01	011-00979-03	115-02250-00	011-02976-00	G1000	5.4 (137)	3.0 (76)	0.8 (20)
G1000 mount	011-03303-40	Sub-Assy, GTX345R, GPS	011-02977-01	011-00979-03	115-02250-00	011-02976-01	G1000	5.4 (137)	3.1 (79)	0.8 (20)

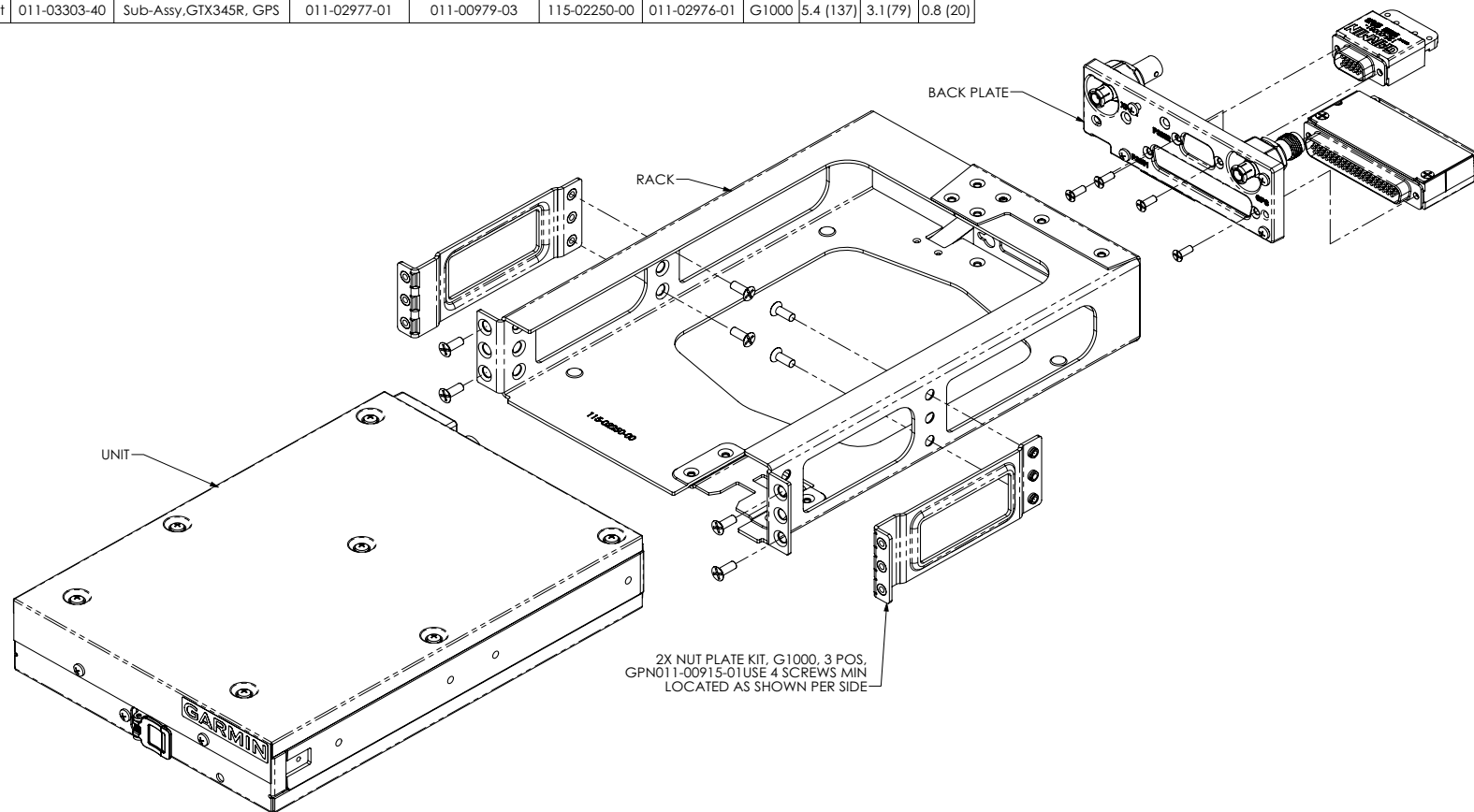

Figure B-7 G1000 Mount Rack Assembly with GTX 345R GPS Shown

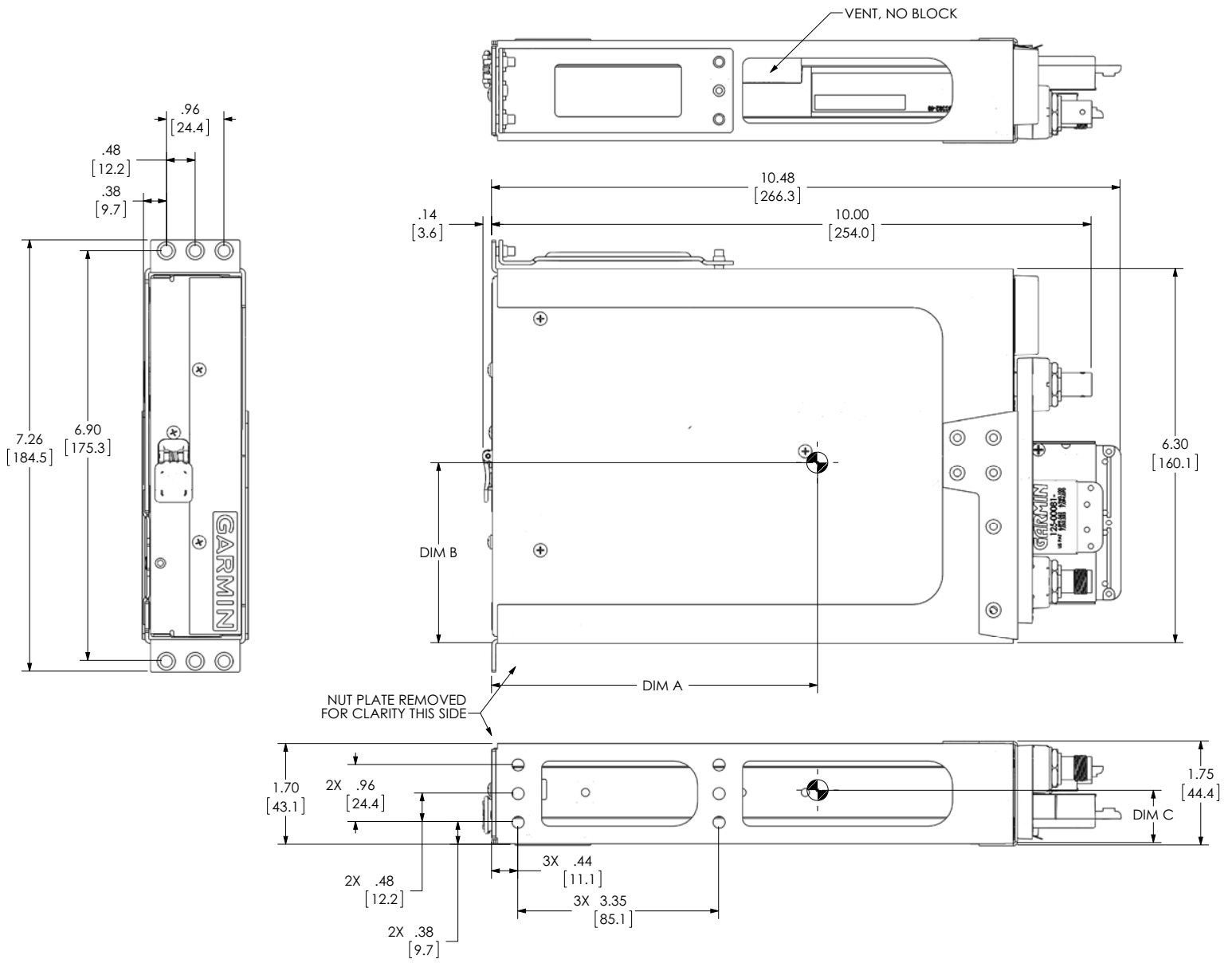
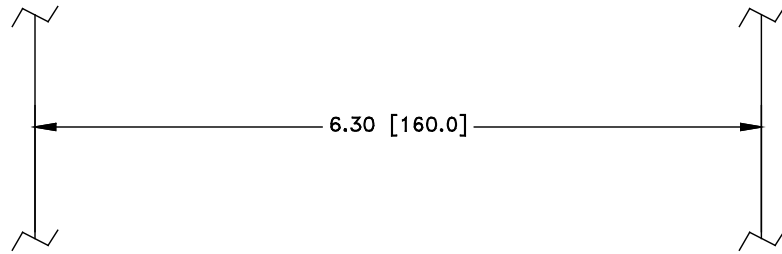

Figure B-8 G1000 Mounting Rack Dimensions and CG with GTX 345R GPS Shown

OPTION 1:

STACK CUTOUT (RACK INSTALLED FROM FRONT OF AIRCRAFT PANEL)



OPTION 2:

RADIO CUTOUT (RACK INSTALLED FROM FRONT OF AIRCRAFT PANEL)

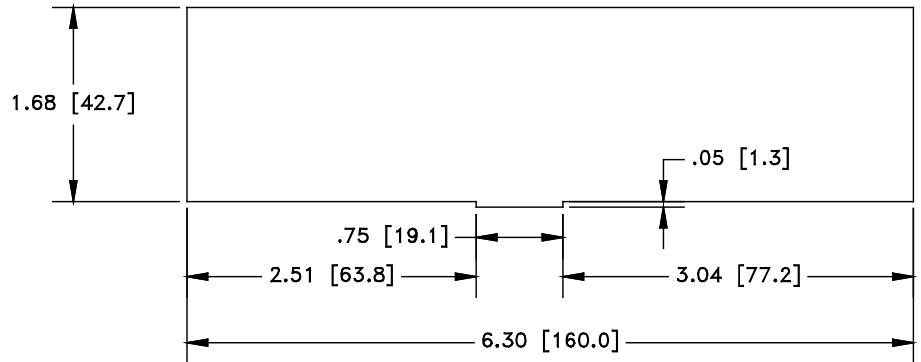

OPTION 3:

RADIO CUTOUT (RACK INSTALLED FROM BACK OF AIRCRAFT PANEL ONLY)
 MAXIMUM AIRCRAFT PANEL THICKNESS IS .125 INCH [3.2 mm]

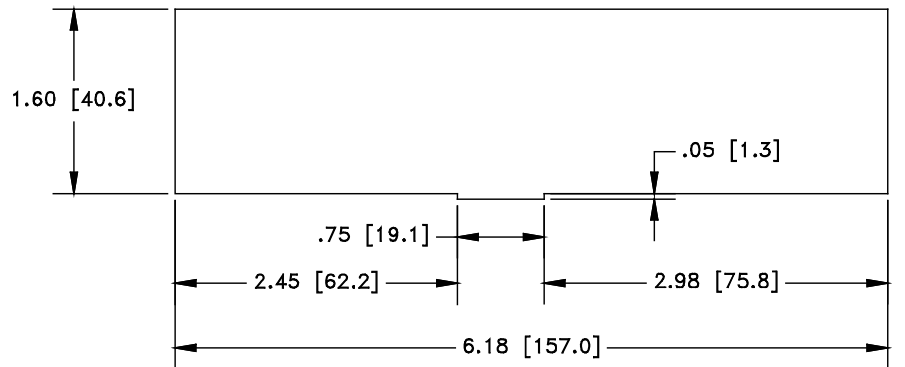

NOTES:

1. DIMENSIONS: INCH [mm].
2. IF THE FRONT LIP OF THE MOUNTING RACK IS BEHIND THE SURFACE OF THE AIRCRAFT PANEL, THE UNIT CONNECTORS MAY NOT FULLY ENGAGE.

Figure B-9 GTX 3X5 Panel Cutout Detail

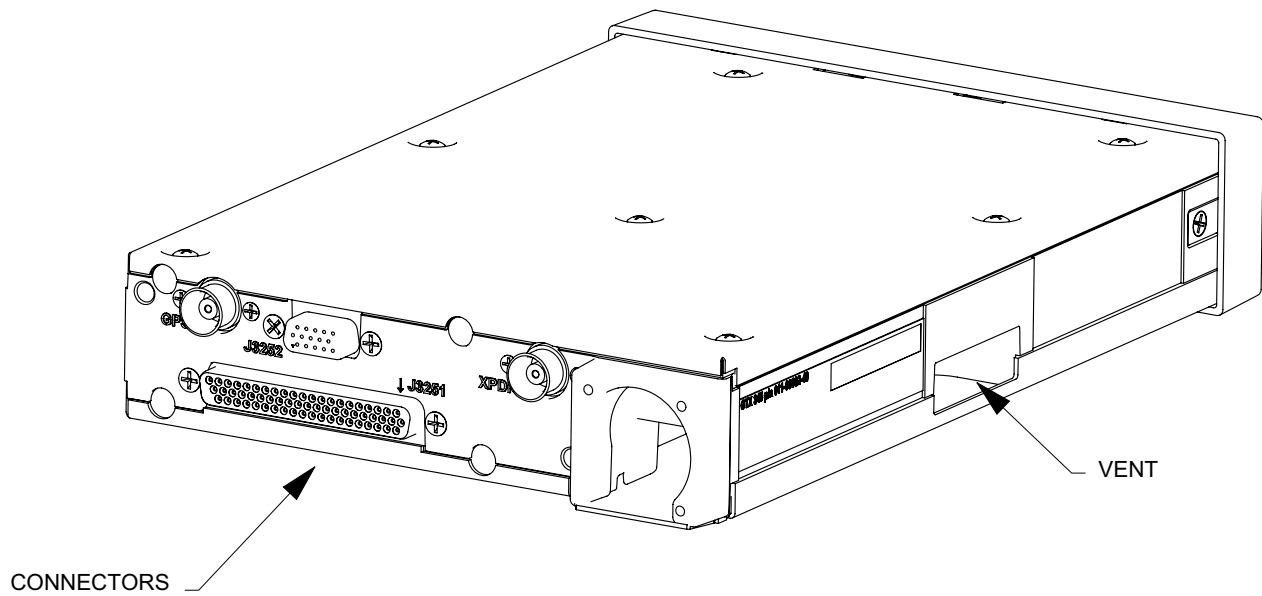
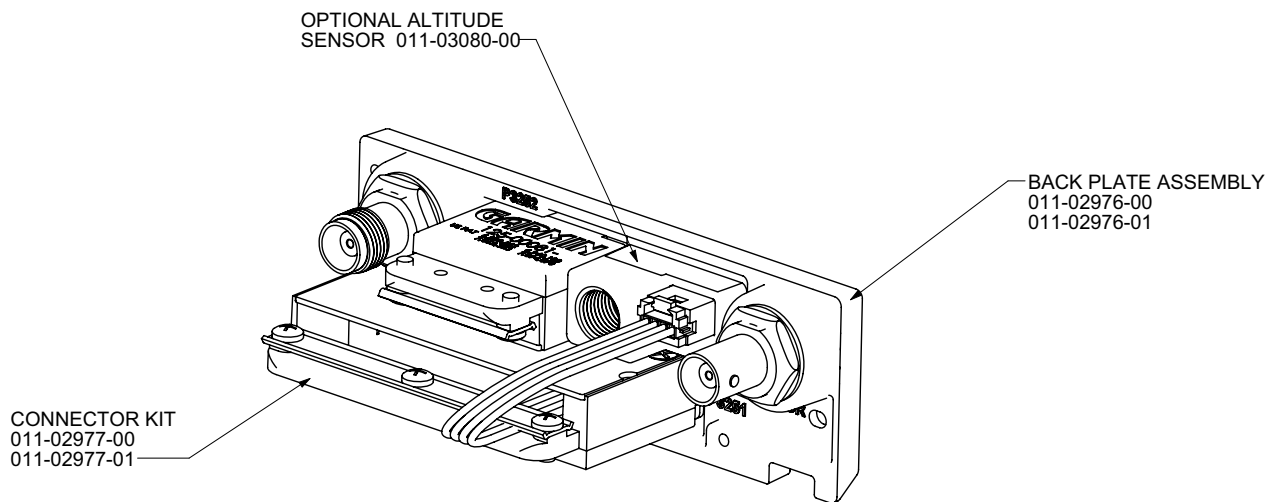

Figure B-10 GTX 3X5 Connector and Vent Locations



GTX BACKPLATE
 PANEL MOUNT
 G1000
 REMOTE

Figure B-11 Optional Garmin Altitude Encoder

APPENDIX C EQUIPMENT COMPATIBILITY AND CONFIGURATION

C.1	ADS-B In Displays	C-2
C.2	GPS Sources	C-3
C.3	Altitude Sources	C-4
C.4	Audio Panels	C-5
C.5	Radar Altimeters	C-6
C.6	Heading Reference Sources	C-6
C.7	Traffic Sensors (GTX 345 Only)	C-8
C.8	Bluetooth	C-9
C.9	Remote Control	C-9
C.10	TIS-A Display	C-10

C.1 ADS-B In Displays

Table C-1 ADS-B In Display

Manufacturer	Model	Data Format	Interface Configuration	GTX 345 Configuration Setting	Notes
Garmin	GTN 6XX/7XX	HSDB	ADS-B In Source: GTX	GTN	
	GNS 400W/ 500W Series [3]	RS-232	ADSB TFC	GNS	Supports traffic only (also includes GPS data from the GNS 400W/500W).
			ADSB TFC WX	GNS	Supports both traffic and weather that includes GPS data from the GNS 400W/500W Series.
		ARINC 429	ADSB TFC	TRAFFIC	Supports ADS-B traffic without TAS/TCAS.
			ADSB TFC w/TCAS	TRAFFIC	Supports ADS-B traffic w/ TAS/TCAS correlation.
	G950/G1000	RS-232	GDL 90	LGCY TRAFFIC	Supports GTX 345R installations only (Legacy ADS-B traffic).
		RS-422	GDL 90 ADS-B	Garmin MX Series 1 [1] OR Off [2]	Supports GTX 345R installations only (FIS-B weather).
	GMX 200	RS-422	FIS Data Link: Enabled GDL 90 UAT Radio: Disp Only GDL 90 Code Edit: Disabled	MX Format 1	
UPSAT	MX20	RS-422	FIS Data Link: Enabled GDL 90 UAT Radio: Disp Only GDL 90 Code Edit: Disabled	MX Format 2	

Notes:

[1] If GDU software v12.00 or later and GIA software v6.20 or later is used.

[2] If GDU software prior to v12.00 or GIA software prior to v6.20 is used.

[3] The GNS 400W/500W interface requires the combination of one RS-232 and one ARINC 429 interface.

C.2 GPS Sources

Table C-2 GPS Source

Manufacturer	Model	Data Format	Interface Configuration	GTX 3X5 Configuration	Notes
Garmin	G950/G1000	RS-232	GTX 33ES #1 [1] OR GTX 33ES #1 w/ TIS [2]	REMOTE FMT 1 [1,3] OR REMOTE FMT 2 [2,3]	Refer to the STC installation manual for guidance. Note that the primary purpose of this interface is transponder control, however this format also includes GPS data. Refer to table C-9.
				LGCY REMOTE 1 [1,4] OR LGCY REMOTE 2 [2,4]	
	Internal	N/A	N/A	Refer to section 6.8.	
	GTN 6XX/7XX	RS-232	ADS-B OUT +	ADS-B + FMT 1	
			HSDB	ADS-B In Source: GTX	GTN - Enabled
	GNS 400W/ 500W	RS-232	ADSB TFC	GNS	Applicable to GTX 345 installations only. Note that the primary purpose of this interface is for ADS-B In Data, however this format also includes GPS data. Refer to table C-1.
			ADSB TFC WX		
			ADS-B OUT +	ADS-B + FMT 1	Supports GPS data only.
	GNS 480	RS-232	GTX + [1]	REMOTE FMT 1 [1]	Note that the primary purpose of this interface is transponder control, however this format also includes GPS data. Refer to table C-9.
			GTX w/TIS+ [2]	REMOTE FMT 2 [2]	
ADS-B OUT +			ADS-B + FMT 1		
GTX 3X5	RS-232	ADS-B + FMT 1	N/A		
		ADS-B + FMT 2	ADS-B + FMT 2		
GDL 84/88 with GPS/SBAS	ARINC 429	743A	RINC 743A		

Notes:

- [1] Installations with no TIS.
- [2] Installations with TIS (GTX 335 only).
- [3] Installations with GDU software v15.00 or later.
- [4] Installations with GDU software prior to v15.00.

C.3 Altitude Sources

Table C-3 Altitude Sources

Manufacturer	Model	Interfacing Equipment Configuration	GTX 335 Configuration Setting	GTX 345 Configuration Setting	Notes
ACT Tech	A-30	N/A	ALT FMT 1 25ft	ALT FMT 1 25 ft	
B&D	90004-003	N/A	ADC	ADC	
Garmin	G950/G1000	GEN PURPOSE (Speed: HIGH)	N/A	EFIS AIR DATA (Speed: HIGH)	Refer to STC for installation guidance. Interface is primarily for providing true heading to the GTX, however this format also provides altitude refer to table C-6. Required if external traffic system is installed.
	GDC 74()	N/A	ADC	ADC	
	GDU 620	GENERAL (Speed: HIGH)	EFIS AIR DATA (Speed: HIGH)	EFIS AIR DATA (Speed: HIGH)	
	GTN 6XX/7XX	GTX Mode S+ [1] OR GTX w/TIS+ [2]	REMOTE FMT 1 [1] OR REMOTE FMT 2 [2]	REMOTE FMT 1 [1] OR REMOTE FMT 2 [2]	This configuration is primarily for purposes of transponder remote control, however this configuration also provides altitude data. Refer to table C-9.
	GAE 12	N/A	Garmin Altitude Encoder: Present	Garmin Altitude Encoder: Present	
Honeywell (Bendix/King)	KDC 281	N/A	ADC	ADC	
	KDC 481	N/A	ADC	ADC	
Icarus Instruments	3000	N/A	ALT FMT 1 100ft	ALT FMT 1 100 ft	
Sandia	SAE 5-35	N/A	ALT FMT 1 25ft	ALT FMT 1 25 ft	Either RS-232 or Gillham Gray code format can be used to provide altitude data from the Sandia SAE 5-35 to the GTX 3X5.
		N/A	Gillham Discrettes ON	Gillham Discrettes ON	

Manufacturer	Model	Interfacing Equipment Configuration	GTX 335 Configuration Setting	GTX 345 Configuration Setting	Notes
Shadin	8800T	25 ft or lower encoding	ALT FMT 3 25 ft	ALT FMT 3 25 ft	Applicable to installations with the 8800T unit configured for 25ft or lower encoding.
		100 ft encoding	ALT FMT 3 100 ft	ALT FMT 3 100 ft	Applicable to installations with the 8800T unit configured for parallel Gray source or 100 ft encoding.
	F/ADC-200	N/A	ADC FMT 1	ADC FMT 1	
	F/ADC-2000	N/A	ADC FMT 1	ADC FMT 1	Either the RS-232 or ARINC 429 data format can be used for the Shadin F/ADC-2000 interface to the GTX (not both).
		N/A	ADC (Speed: LOW)	ADC (Speed: LOW)	
Trans-Cal Industries	IA-RS232-X	N/A	ALT FMT 1 100 ft	ALT FMT 1 100 ft	
	SSD120	25 ft or lower encoding	ALT FMT 1 25 ft	ALT FMT 1 25 ft	Applicable to installations with the SSD120 unit configured for 25ft or lower encoding.
		100 ft encoding	ALT FMT 1 100 ft	ALT FMT 1 100 ft	Applicable to installations with the SSD120 unit configured for parallel Gray source or 100 ft encoding.

[1] Installation with no TIS traffic.

[2] Installation with TIS traffic (GTX 335 only).

C.4 Audio Panels

Table C-4 Audio Panels

Manufacturer	Model	Data Format	GTX 3X5 Configuration Setting
Garmin	SL10, SL10MS, SL10M, SL10S, SL15, SL15M, GMA 340, GMA 347, GMA 35, GMA 350	Analog Audio	Audio: XPDR
Honeywell (Bendix/King)	KMA 24, KMA 24H-70/71, KMA 26, DMA 28		
PS Engineering	PMA 6000, PMA 7000 Series, PMA 8000 Series		

C.5 Radar Altimeters

Table C-5 Radar Altimeters

Manufacturer	Model	Data Format	Interface Configuration	GTX 3X5 Configuration
Free Flight	RA-4500	ARINC 429	N/A	RADIO ALTITUDE
Garmin	GRA 55/5500			
Honeywell (Bendix King)	KRA 405B			

C.6 Heading Reference Sources

Table C-6 Heading Reference Source

Manufacturer	Model	Configuration Parameter	Interfacing Equipment Configuration	GTX 335 Configuration Setting	GTX 345 Configuration Setting	Notes
Aspen	EFD1000	ARINC 429	N/A	HEADING [1] (Speed: LOW)	HEADING [1] (Speed: LOW)	Applicable to GTX 3X5 installations only
Avidyne	EXP5000 700-00006-()	ARINC 429		HEADING [1] (Speed: LOW)	HEADING [1] (Speed: LOW)	Applicable to GTX 3X5 installations only
Collins	AHC-85E	ARINC 429		AHRS [2] (Speed: HIGH)	AHRS [2] (Speed: HIGH)	
Garmin	G950/G1000	ARINC 429	GEN PURPOSE	N/A	EFIS AIR DATA [3] (Speed: HIGH)	Refer to STC installation guidance.
	GRS 77	ARINC 429	N/A	AHRS [2] (Speed: HIGH)	AHRS [2] (Speed: HIGH)	
	GAD 42	ARINC 429	N/A	HEADING [1] (Speed: LOW)	HEADING [1] (Speed: LOW)	Applicable to GTX 3X5 installations only.
	GDU 620	ARINC 429	GENERAL	EFIS AIR DATA [3] (Speed: HIGH)	EFIS AIR DATA [3] (Speed: HIGH)	Applicable to GTX 3X5 installations only. Note that this interface also provides altitude data. Refer to table C-3.
	GTN 6XX/7XX	RS-232	GTX Mode S+ [4] OR GTX w/TIS+ [5]	REMOTE FMT 1 [4] OR REMOTE FMT 2 [5]	REMOTE FMT 1 [4] OR REMOTE FMT 2 [5]	This configuration is primarily for purposes of transponder remote control, however this configuration also provides magnetic heading. Refer to table C-9.
	GNS 400W/500W	ARINC 429	ARINC 429	HEADING [1] (Speed: HIGH)	HEADING [1] (Speed: HIGH)	Applicable to GTX 3X5 installations only

Manufacturer	Model	Configuration Parameter	Interfacing Equipment Configuration	GTX 335 Configuration Setting	GTX 345 Configuration Setting	Notes
Honeywell (Bendix/King)	EFIS 40/50 (SG 465)	ARINC 429	N/A	HEADING [1] (Speed: LOW)	HEADING [1] (Speed: LOW)	Applicable to GTX 3X5 installations only
Sandel	SN3500	ARINC 429		AHRS [2] (Speed: LOW)	AHRS [2] (Speed: LOW)	
	SN3308			AHRS [2] (Speed: LOW)	AHRS [2] (Speed: LOW)	

Notes:

- [1] Heading information only.
- [2] Attitude and heading information.
- [3] Altitude, airspeed, altitude rate, and heading information.
- [4] Installation with no TIS traffic.
- [5] Installation with TIS traffic (GTX 335 only).

C.7 Traffic Sensors (GTX 345 Only)

Table C-7 Traffic Sensors

Manufacturer	Model	Configuration Parameter	I/O (To/From GTX)	Interfacing Equipment Configuration	GTX 345 Configuration Setting	Notes
Avidyne	RYAN TAS 600 (9900BX)	RS-232	Input/Output	N/A	TRAFFIC FMT 4	Configuration setting available on RS-232 Channel 4 only
Garmin	GTS 8XX	ARINC 429	Input	Traffic Display Destination (Primary TX) [1]	TRAFFIC 1 (Speed - HIGH)	
			Output [2]	Transponder 1 Communication (Primary RX) [1]	FORMAT 4 (Speed - HIGH)	Data format includes Garmin TAS.
				Pressure Altitude Source (Primary RX); Magnetic Heading Source (Primary RX); GPS Position/Velocity/Time Source (Primary RX); Transponder 1 Communication (Primary RX) [1]	FORMAT 5 (Speed - HIGH)	Data format includes Garmin TAS as well as Garmin concentrator; required for G1000.
N/A	Transponder 1 Communication (Primary TX) [1] (Speed - LOW)	N/A	This interface is required for GTS 8xx installations, even though it does not correspond to physical interface/wiring (configure for an unused ARINC 429 output port on the GTS 8XX).			
Honeywell (Bendix/King)	KTA 870/810 KMH 880/820 KTA 970/910 KMH 980/920	ARINC 429	Input	Controller - Discrete Intruder File Protocol - ARINC 735	TRAFFIC 5 (Speed - HIGH)	
L3 Comm	SKY 497 SKY 899	ARINC 429	Input	N/A	TRAFFIC 2 (Speed - HIGH)	

Notes:

- [1] Configure the listed function(s) with the appropriate ARINC 429 channel based on the specific installation.
- [2] ARINC 429 output from GTX 345 to GTS 800 is not required, but is required for all other GTS 8XX units.

C.8 Bluetooth

Table C-8 Bluetooth

Manufacturer	Model	Data Format	Input/Output	GTX 345 Configuration Setting	Notes
Garmin	Internal	Bluetooth	N/A	Bluetooth: Enabled	
	Flight Stream 110/210	RS-232	Input	CONNEXT FMT 3	Both the RS-232 input and RS-422 output are required; internal Bluetooth must be disabled on the GTX with a FS 110/210 installation.
		RS-422	Output	CONNEXT FMT 3	

C.9 Remote Control

Table C-9 Remote Control

Manufacturer	Model	Data Format	Interface Configuration	GTX 335 Configuration Setting	GTX 345 Configuration Setting	Notes
Garmin	GTN 6XX/7XX	RS-232	GTX Mode S+	REMOTE FMT 1	REMOTE FMT 1	Installations with no TIS
			GTX w/TIS+	REMOTE FMT 2	N/A	Installations with TIS
	GNS 480	RS-232	GTX+	REMOTE FMT 1	REMOTE FMT 1	Installations with no TIS
			GTX w/TIS+	REMOTE FMT 2	N/A	Installation with TIS
	G950/G1000	RS-232	GTX 33 [1] OR GTX 33ES [2]	REMOTE FMT 1 [3] OR LGCY REMOTE 1 [4]	REMOTE FMT 1 [3] OR LGCY REMOTE 1 [4]	Installations with no TIS. Refer to STC installation manual for guidance.
			GTX 33 w/TIS [1] OR GTX 33ES w/TIS [2]	REMOTE FMT 2 [3] OR LGCY REMOTE 2 [4]	N/A	Installations with TIS. Refer to STC installation manual for guidance.

Notes:

- [1] GDU software prior to v9.10.
- [2] GDU software v9.10 or later.
- [3] GDU software v15.00 or later.
- [4] GDU software prior to v15.00.

C.10 TIS-A Display

Table C-10 TIS-A Displays

Manufacturer	Model	Data Format	Interface Configuration	GTX 335 Configuration Setting	Notes
Garmin	GTN 6XX/7XX	RS-232	GTX w/TIS+	REMOTE FMT 2	Note that the primary purpose of this interface is for remote control, however this format also includes TIS-A data. Refer to table C-9.
	GDU 620	ARINC 429	GTX 330	FORMAT 8	
	GNS 400W/500W Series	ARINC 429	GARMIN GTX 330	FORMAT 8	
	GNS 480	RS-232	GTX w/TIS+	REMOTE FMT 2	Note that the primary purpose of this interface is for remote control, however this format also includes TIS-A data. Refer to table C-9..
	G950/G1000	RS-232	GTX 33 w/TIS [1] OR GTX 33ES w/TIS [2]	REMOTE FMT 2 [3] OR LGCY REMOTE 2 [4]	Note that the primary purpose of this interface is for remote control, however this format also includes TIS-A data. Refer to table C-9..

Notes:

- [1] GDU software prior to v9.10.
- [2] GDU software v9.10 or later.
- [3] GDU software v15.00 or later.
- [4] GDU software prior to v15.00.

APPENDIX D INTERCONNECT DRAWINGS

Figure D-1	GTX 3X5 Power Configuration Typical Interconnect	D-3
Figure D-2	GTX 345 - Legacy G1000 Interconnect	D-5
Figure D-3	GTX 335 - Legacy G1000 Interconnect	D-7
Figure D-4	GTX 3X5 - GNS 480 (CNX80) Interconnect	D-8
Figure D-5	GTX 335 - GTN 6XX/7XX Typical Interconnect	D-9
Figure D-6	Single/Dual GTX 335 - Single GTN 6XX/7XX Interconnect	D-11
Figure D-7	GTX 345 - GTN 6XX/7XX Typical Interconnect	D-12
Figure D-8	GTX 345 - Single/Dual GTN 6XX/7XX Interconnect	D-14
Figure D-9	GTX 335/345 - GDL 88 Interconnect	D-16
Figure D-10	GTX 345 - Traffic Sensor Interconnect	D-17
Figure D-11	GTX 345 - Single and Dual 400W/500W Series	D-18
Figure D-12	GTX 3X5 - Audio Interconnect	D-19
Figure D-13	GTX 3X5 - Radio Altimeter Interconnect	D-20
Figure D-14	GTX 3X5 - AHRS/Heading Source	D-21
Figure D-15	GTX 3X5 - Switches and OAT Probe Interconnect	D-22
Figure D-16	GTX 3X5 - Altitude Source Interconnect	D-23
Figure D-17	GTX 335 - GNS 400W/500W Series Interconnect	D-25
Figure D-18	GTX 345/345R - Flight Stream Interconnect	D-26
Figure D-19	GTX 345 - MX20/GMX 200 Interconnect	D-26
Figure D-20	GTX 335 - GDU 620 Interconnect	D-27

This section contains wiring interconnect details and examples for the connections necessary for the installation of the GTX 33X and GTX 3X5 Series transponders.

Each figure contained in this section has notes that must be followed. These general notes apply to all of the figures contained in this section.

- Unless specified differently, all wires are 24 AWG or larger.
- Power and ground connections are 22 AWG wire for run lengths less than 10 feet, if not, use 18 AWG.
- Use oversize contacts in the connector kit for wire sizes greater than 22 AWG.
- In 14 VDC installations, use two power pins and two ground pins for power and ground connections.
- In 28 VDC installations, use only one wire for power and ground connections.
- Antennas and associated cables are shown for reference only.
- In dual GTX transponder installations, each transponder must be grounded through separate ground terminal/stud locations on the aircraft.
- If practical, power and ground wires should be routed separately for each transponder.
- Route grounds and wire separately to improve safety if there is a wiring or grounding system failure.
- Designations for ground connections:

 Shield Block Ground
  Airframe Ground

- Shield ground terminations to the connector backshell must be 3.0 inches or less in length.
- Ground terminations of interfaced equipment can vary. Refer to the manufacturer's installation manual for information.
- HDSB Ethernet wiring must use 24 AWG aircraft grade category 5 Ethernet cable:

Manufacturer	P/N
PIC Wire and Cable	10424
Carlisle IT	39204

- RS-232 and ARINC 429 ports shown are suggested port configurations.
- Installations can require alternate port configurations and are acceptable provided the equipment interfaces and data formats are available on alternate ports.

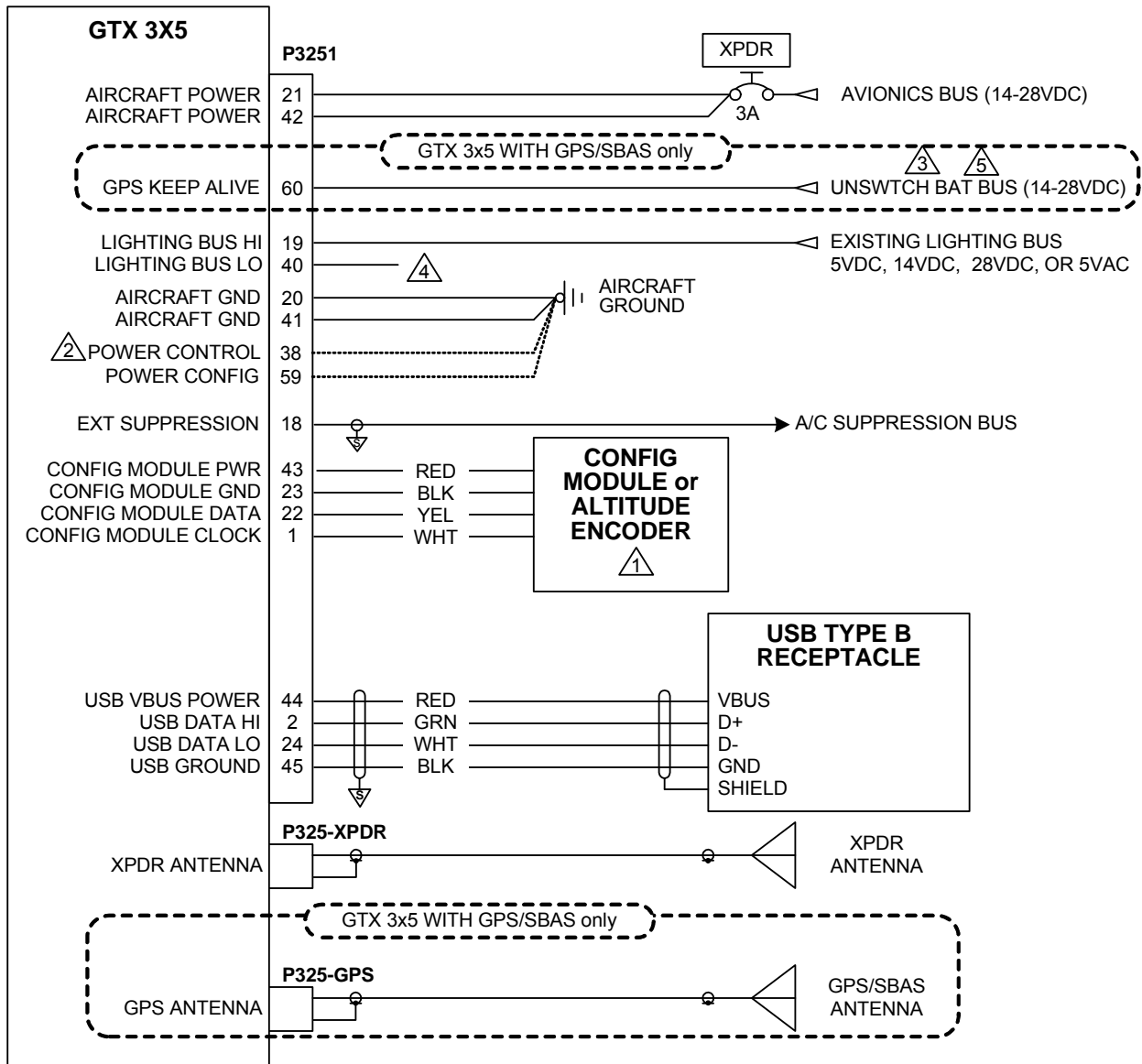

Figure D-1 GTX 3X5 Power Configuration Typical Interconnect
Sheet 1 of 2

NOTES



CONFIG MODULE REQUIRES WIRE HARNESS P/N: 325-00122-00. PRESSURE SENSOR/CONFIG MODULE REQUIRES WIRE HARNESS P/N: 325-00421-00. MODULE WIRE HARNESSES ARE NOT INTERCHANGEABLE. WIRE COLOR IN MODULE WIRE HARNESS DESIGNATES FUNCTION. CONNECT MODULE WIRE HARNESS TO GTX 3X5 ACCORDING TO WIRE COLOR.



REFER TO SECTION 5.3.1 FOR DETAILS.



GPS KEEP ALIVE IS RECOMMENDED FOR GPS INSTALLS. IF NOT CONNECTED GPS MAY TAKE UP TO 20 MINUTES TO OBTAIN A GPS FIX.



REFER TO SECTION 5.4 FOR LIGHTING BUS CONNECTIONS.



GPS KEEP ALIVE MUST BE CONNECTED TO THE UNSWITCHABLE BATTERY BUS (BUS DIRECTLY CONNECTED TO THE BATTERY).

Figure D-1 GTX 3X5 Power Configuration Typical Interconnect Sheet 2 of 2

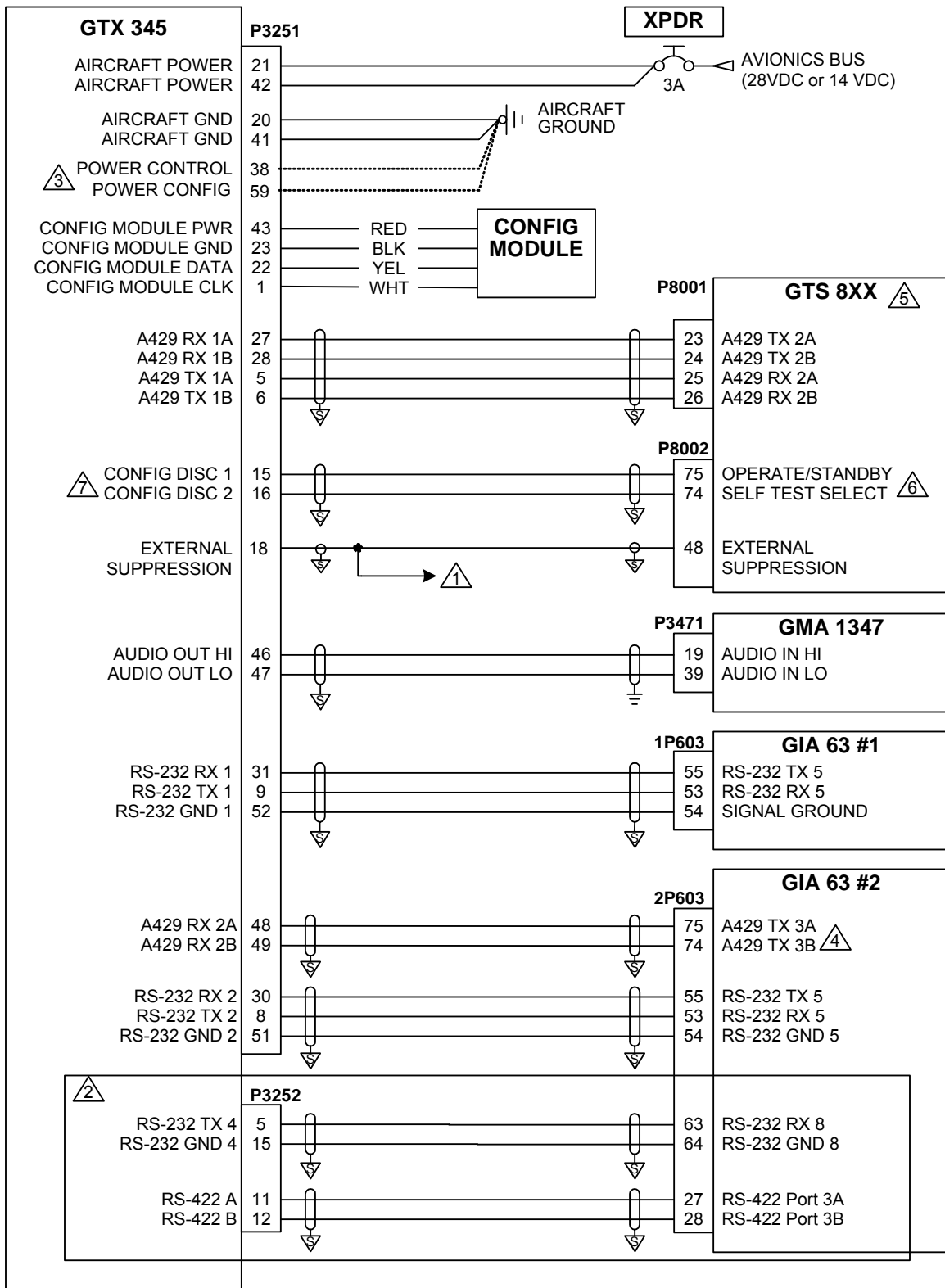

Figure D-2 GTX 345 - Legacy G1000 Interconnect
Sheet 1 of 2

NOTES



CONNECTION TO AIRCRAFT SUPPRESSION BUS.



GDL 90 EMULATION - RS-422 FIS-B CONNECTION AND RS-232 ADS-B IN TRAFFIC.



REFER TO SECTION 5.3.1



PROVIDES TRUE HEADING TO UNIT, REQUIRED IF EXTERNAL TRAFFIC SYSTEM IS INSTALLED. USE ANY AVAILABLE ARINC 429 PORT. THIS MUST BE CONFIGURED BY THE INSTALLER.



GTS 8XX SHOWN AS AN EXAMPLE, REFER TO EXTERNAL TRAFFIC SENSORS FOR ALTERNATE EXTERNAL TRAFFIC SYSTEM OPTIONS.



GTX 345 PROVIDES AUTOMATIC CONTROL OF OPERATE/STANDBY BASED ON AIRBORNE STATUS. GTX 3X5 INSTALL TOOL PROVIDES TRAFFIC SELF TEST DISCRETE FOR EXTERNAL TRAFFIC VALIDATION.

7

THIS DIAGRAM PROVIDES AN OVERVIEW OF A TYPICAL INSTALLATION. REFER TO APPLICABLE INTERCONNECT DIAGRAMS FOR SPECIFIC EQUIPMENT.

**Figure D-2 GTX 345 - Legacy G1000 Interconnect
Sheet 2 of 2**

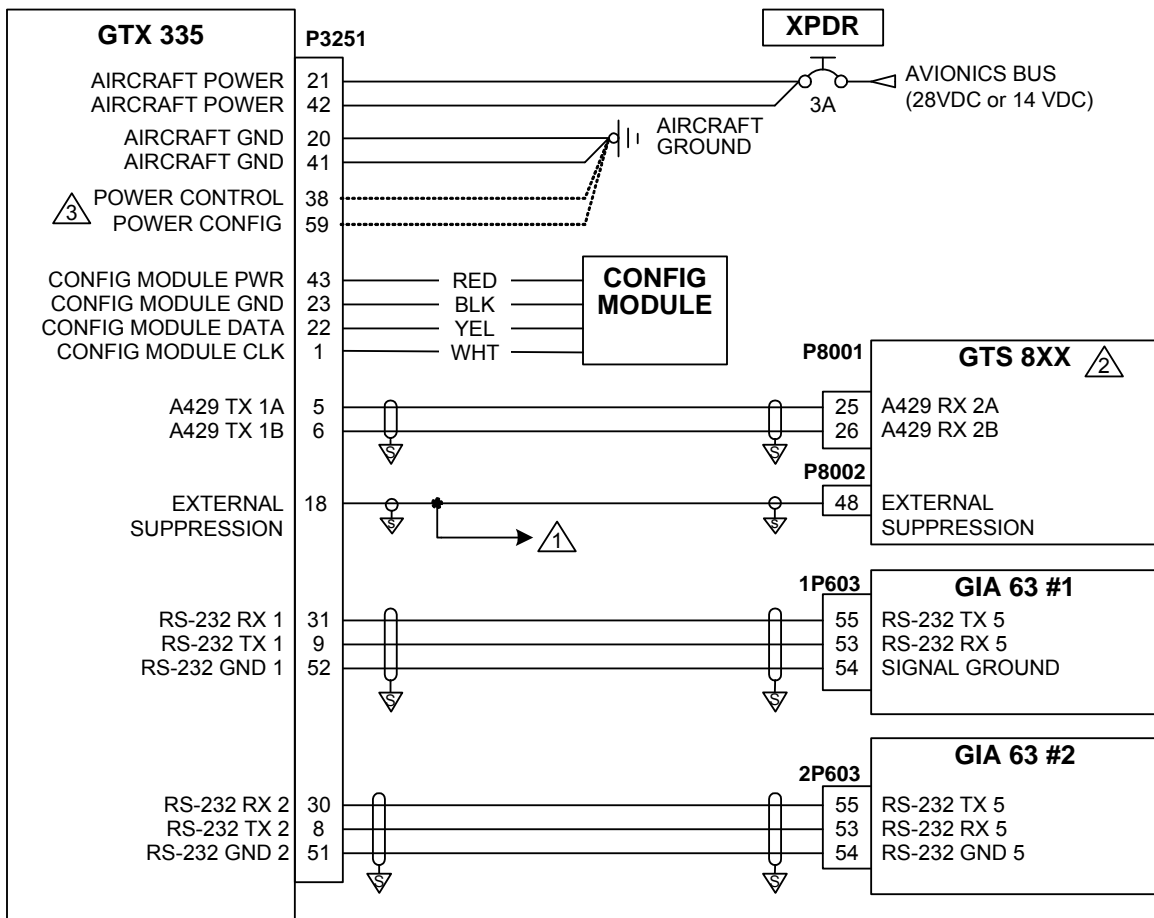

NOTES



CONNECTION TO AIRCRAFT SUPPRESSION BUS.



GTS 8XX IS THE ONLY SUPPORTED TRAFFIC SYSTEM THAT INTERFACES WITH THE GTX 335.



REFER TO SECTION 5.3.1 FOR DETAILS.

Figure D-3 GTX 335 - Legacy G1000 Interconnect

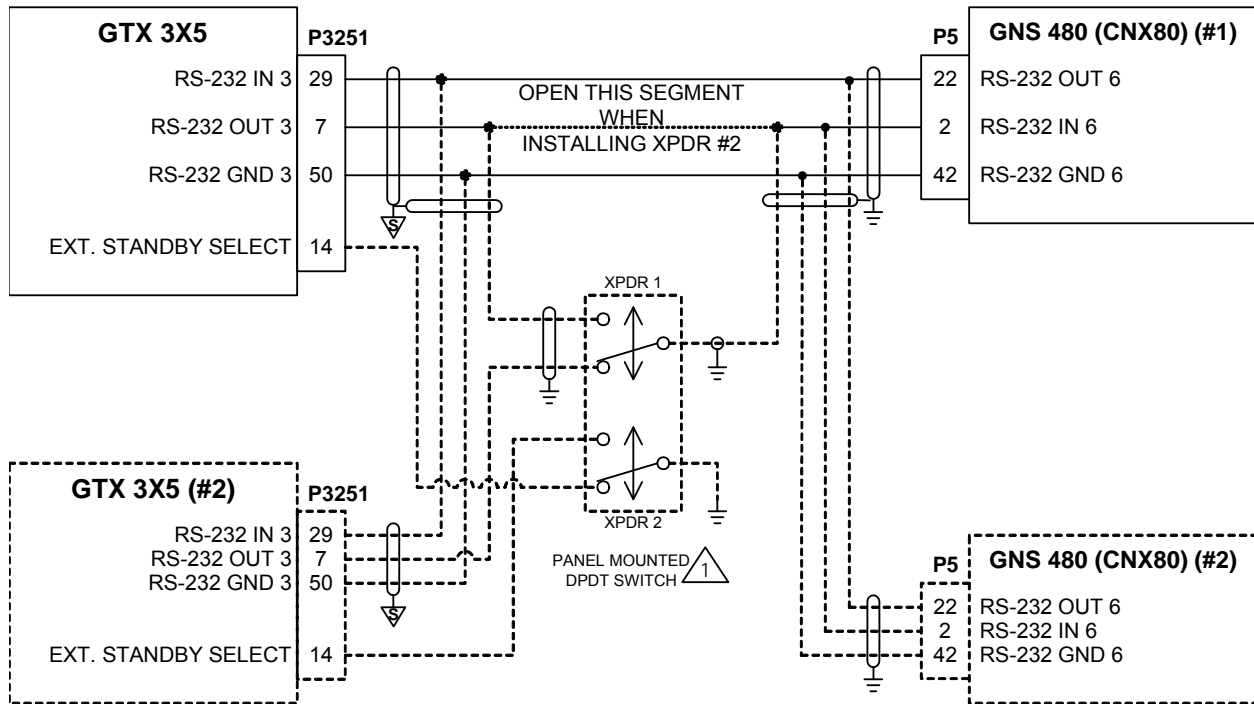

NOTES



1 WHEN INSTALLING A SECOND TRANSPONDER, A SWITCH MUST BE INSTALLED TO LET ONLY ONE TRANSPONDER TO BE ACTIVE AT A TIME. SUITABLE DPDT SWITCHES: C&K 7000 SERIES P/N 7201SYZQE, OR EQUIVALENT.

2

DASHED LINES AND AREAS REPRESENT TRANSPONDER #2 AND GNS 480 (CNX80) #2 INSTALLATION DETAILS.

Figure D-4 GTX 3X5 - GNS 480 (CNX80) Interconnect

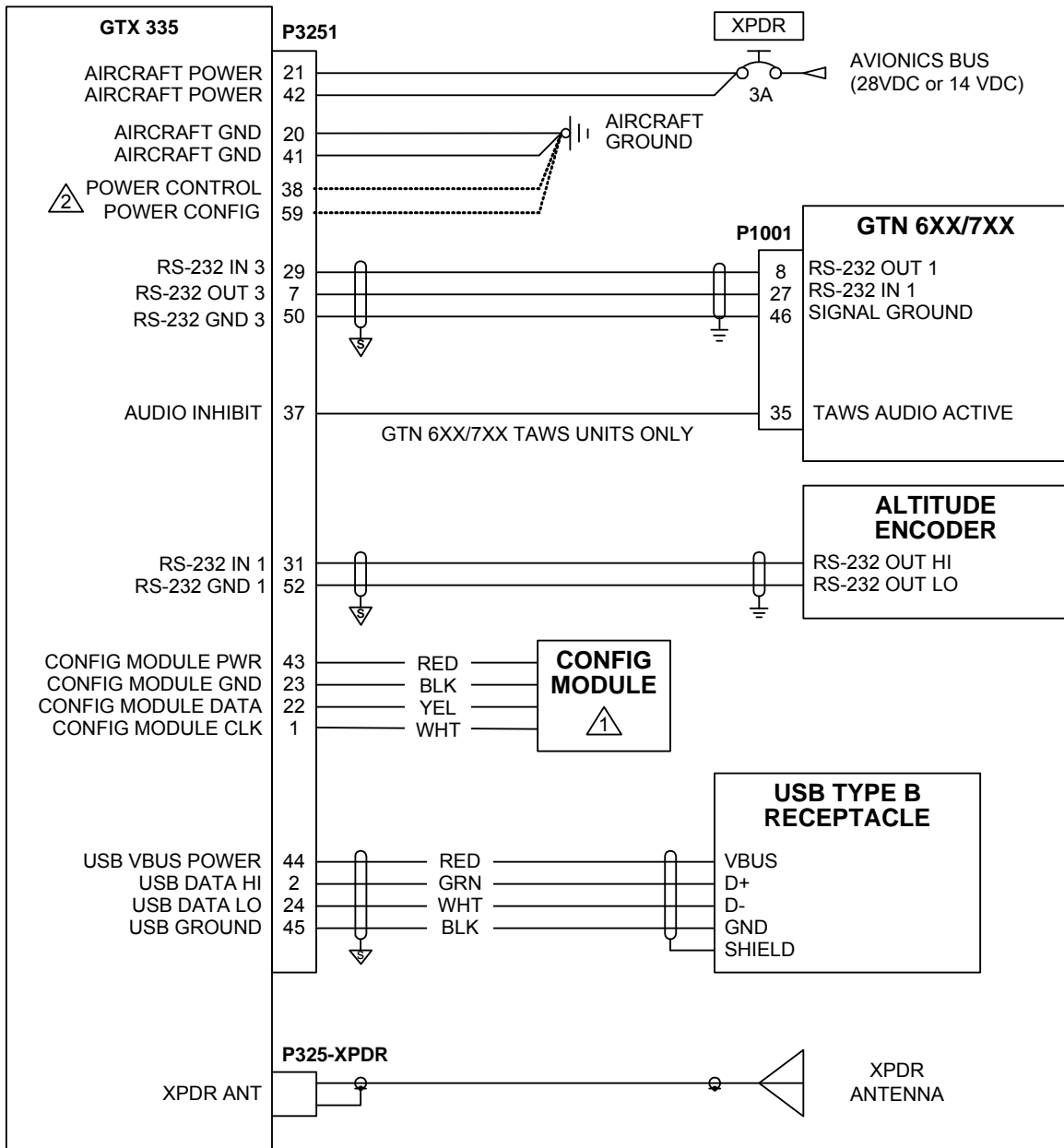

Figure D-5 GTX 335 - GTN 6XX/7XX Typical Interconnect
Sheet 1 of 2

NOTES

CONFIG MODULE REQUIRES WIRE HARNESS P/N: 325-00122-00. PRESSURE SENSOR/CONFIG MODULE REQUIRES WIRE HARNESS P/N: 325-00421-00. MODULE WIRE HARNESSES ARE NOT INTERCHANGEABLE. WIRE COLOR IN MODULE WIRE HARNESS DESIGNATES FUNCTION. CONNECT MODULE WIRE HARNESS TO GTX 3X5 ACCORDING TO WIRE COLOR.



REFER TO SECTION 5.3.1 FOR DETAILS.

**Figure D-5 GTX 335 - GTN 6XX/7XX Typical Interconnect
Sheet 2 of 2**

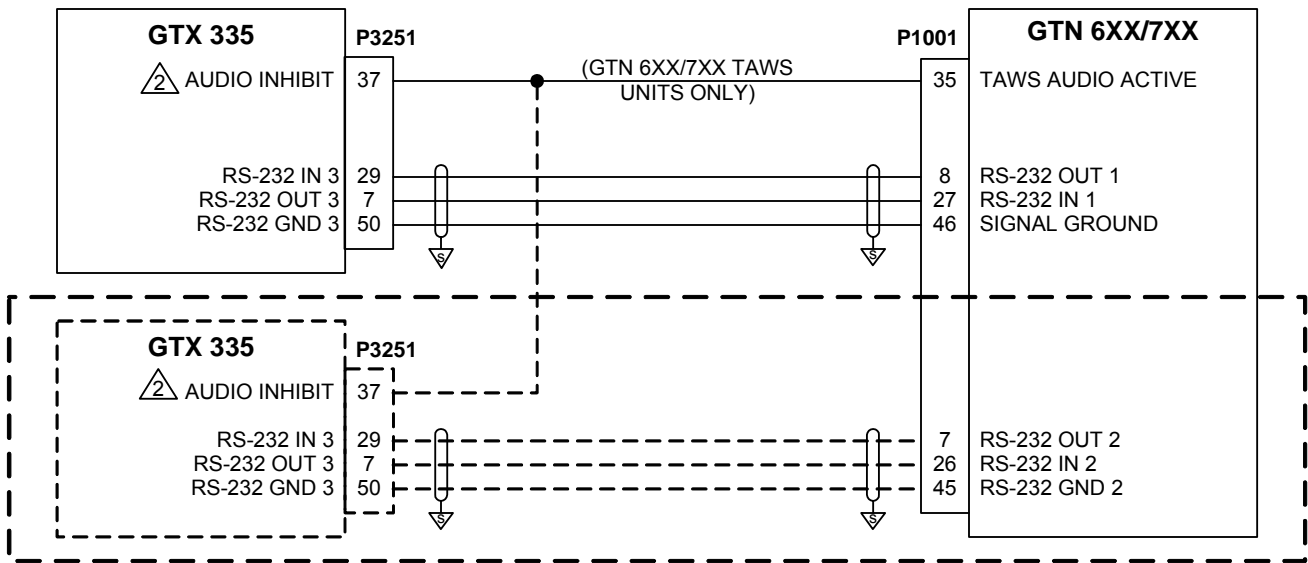

NOTES

1

DASHED AREAS INDICATE ADDITIONAL INTERCONNECTS FOR DUAL INSTALLATION AND ARE NOT REQUIRED FOR SINGLE INSTALLATION.



AUDIO INHIBIT I/O PIN IS CONFIGURABLE. REFER TO PIN CONFIGURATION SECTION FOR DETAILS.

Figure D-6 Single/Dual GTX 335 - Single GTN 6XX/7XX Interconnect

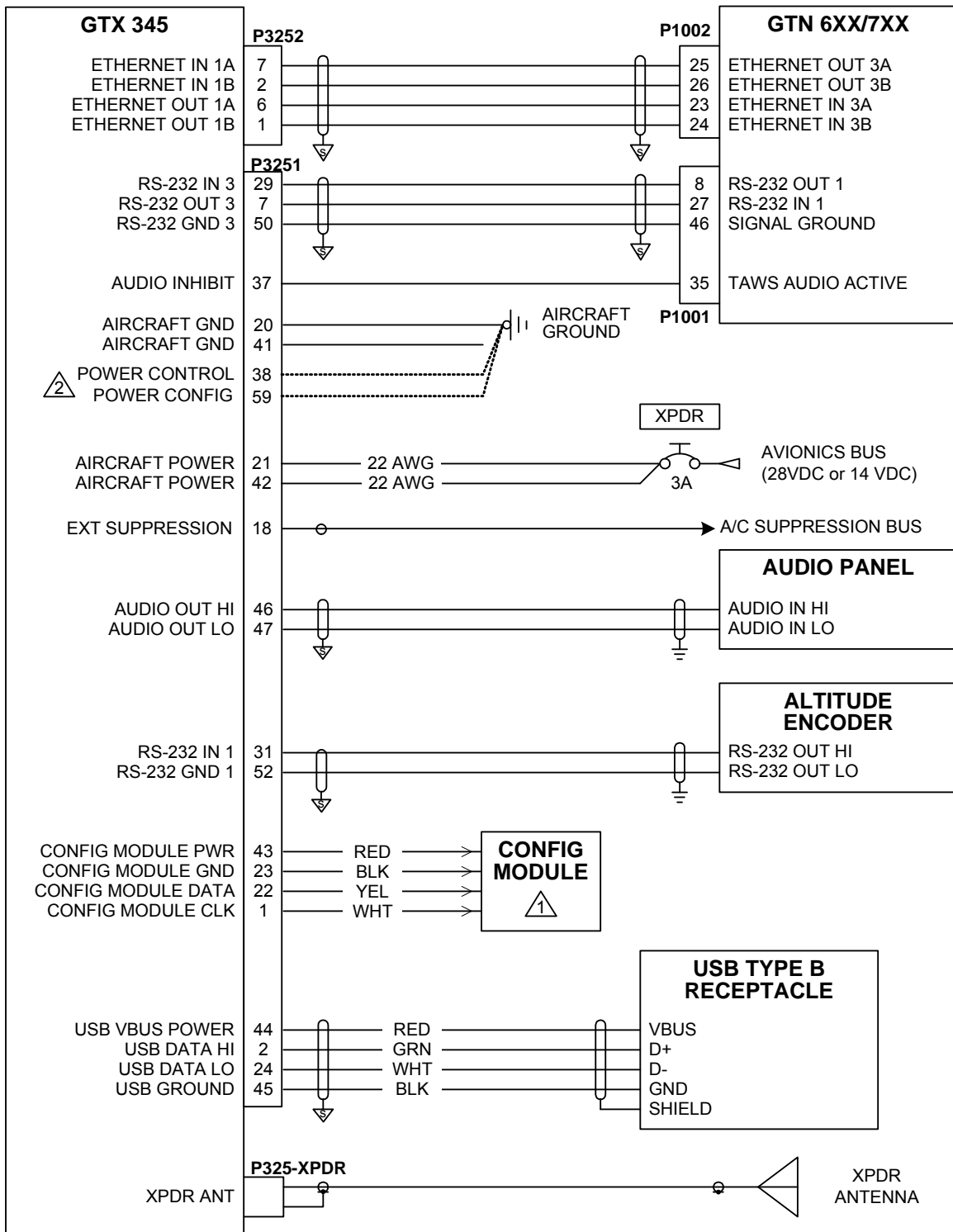

Figure D-7 GTX 345 - GTN 6XX/7XX Typical Interconnect
Sheet 1 of 2

NOTES

CONFIG MODULE REQUIRES WIRE HARNESS P/N: 325-00122-00. PRESSURE SENSOR/CONFIG MODULE REQUIRES WIRE HARNESS P/N: 325-00421-00. MODULE WIRE HARNESSES ARE NOT INTERCHANGEABLE. WIRE COLOR IN MODULE WIRE HARNESS DESIGNATES FUNCTION. CONNECT MODULE WIRE HARNESS TO GTX 3X5 ACCORDING TO WIRE COLOR.



REFER TO SECTION 5.3.1 FOR DETAILS.

**Figure D-7 GTX 345 - GTN 6XX/7XX Typical Interconnect
Sheet 2 of 2**

SINGLE GTX 345 or GTX 345R with SINGLE GTN 6XX/7XX

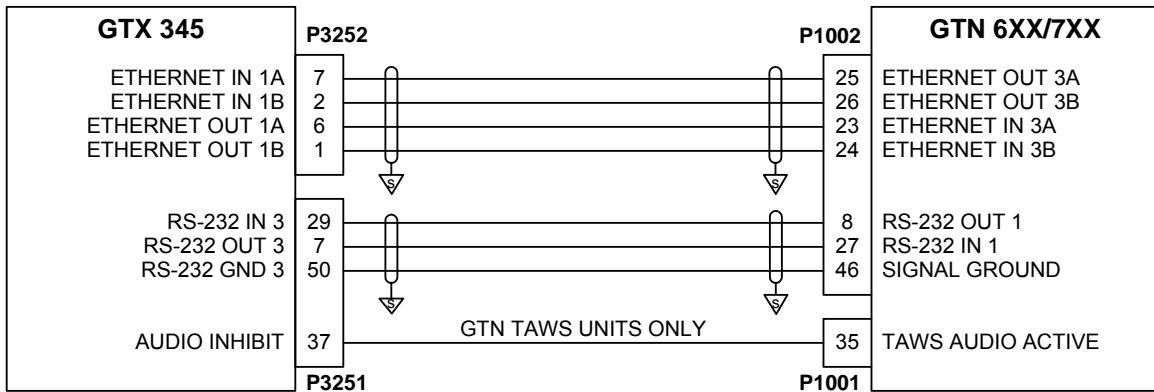

SINGLE GTX 345 or GTX 345R with DUAL GTN 6XX/7XXs

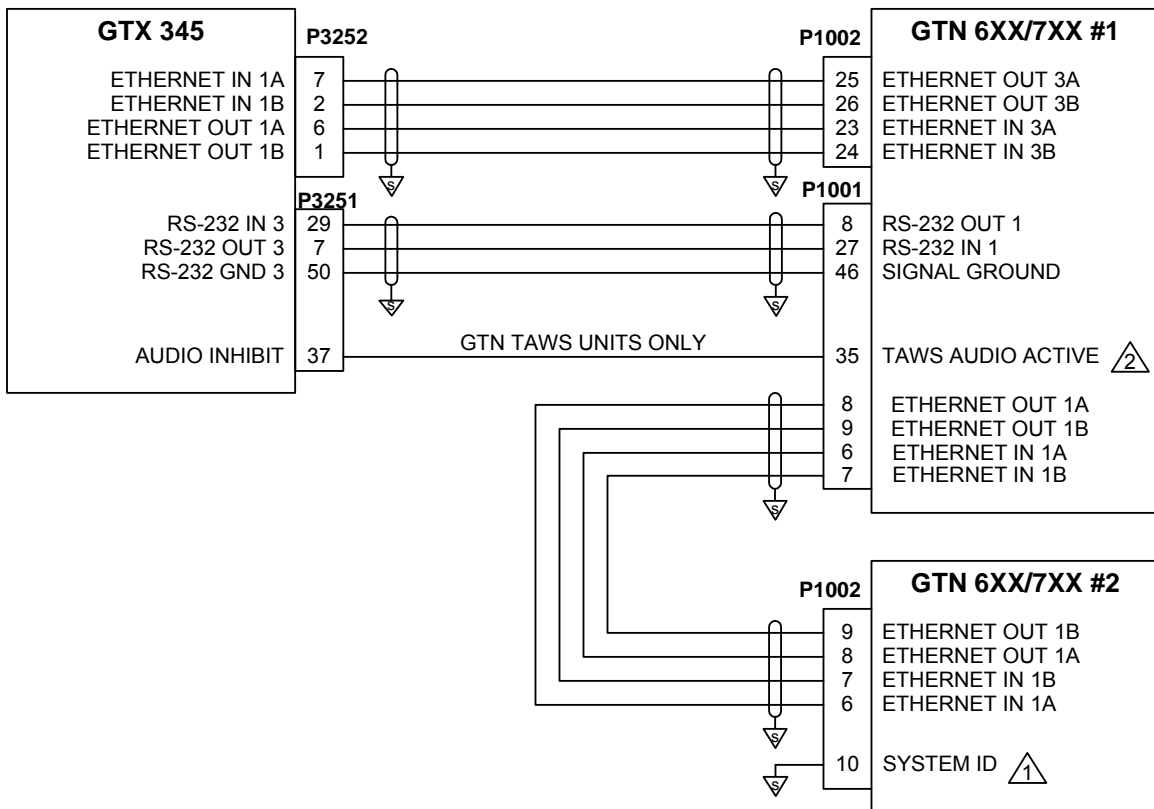

Figure D-8 GTX 345 - Single/Dual GTN 6XX/7XX Interconnect
Sheet 1 of 2

NOTES

WHEN GTN 6XX/7XX IS THE ONLY INSTALLED GPS NAVIGATOR, OR GPS NAVIGATOR #1 IN A DUAL GPS NAVIGATOR INSTALLATION, CONFIGURE GTN 6XX/7XX AS GTN #1 BY LEAVING SYSTEM ID (P1002-10) NOT CONNECTED. WHEN THE GTN 6XX/7XX IS GPS NAVIGATOR #2 IN A DUAL GPS INSTALLATION, CONFIGURE GTN #2 BY GROUNDING SYSTEM ID (P1002-10) TO THE SHIELD BLOCK.



TAWS AUDIO INHIBIT FOR GTN 6XX/7XX TAWS UNITS ONLY.

**Figure D-8 GTX 345 - Single/Dual GTN 6XX/7XX Interconnect
Sheet 2 of 2**

GTX 335/345 PROVIDING GPS POSITION TO GDL 88

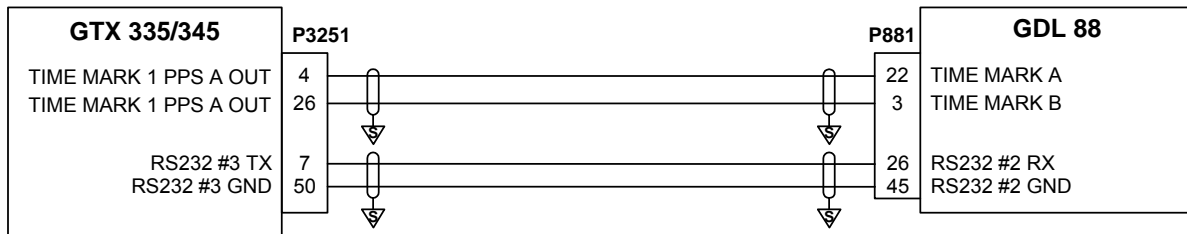

GDL 88 PROVIDING GPS POSITION TO GTX 335/345

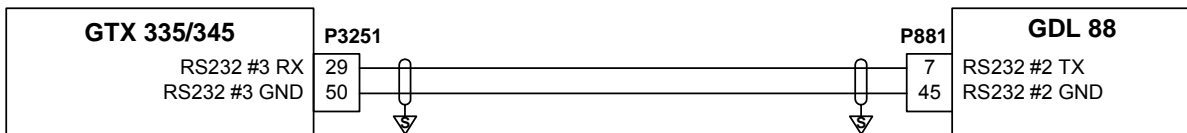

NOTES

- 1 ADS-B + FORMAT 2 SHOULD BE USED FOR BOTH INTERFACES.

Figure D-9 GTX 335/345 - GDL 88 Interconnect

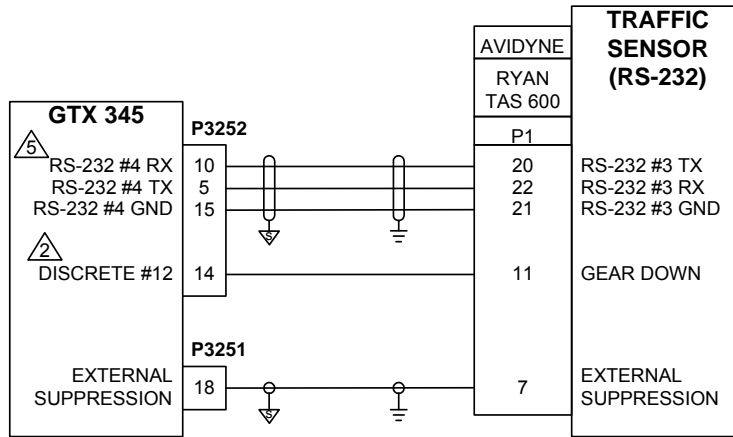
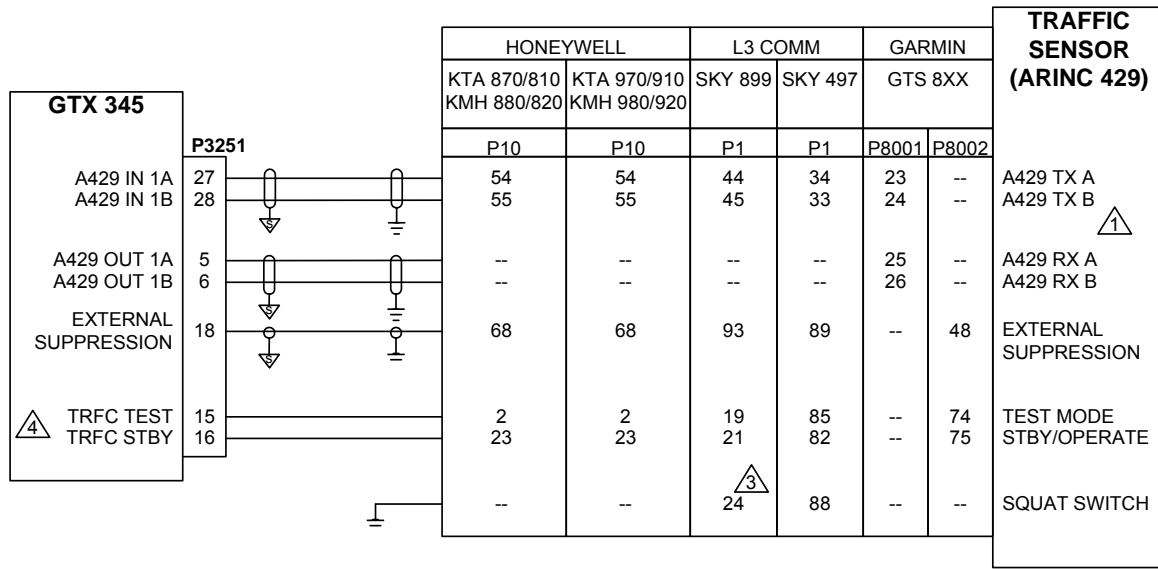

NOTES



REFER TO THE STC INSTALLATION MANUAL FOR ADDITIONAL INFORMATION WHEN INTERFACING THE GTX 345 AND AN EXTERNAL TRAFFIC SENSOR IN A LEGACY G1000 INSTALLATION.



IF THIS DISCRETE IS ALREADY USED, ANY CONFIGURABLE OUTPUT DISCRETE CAN BE USED.



CONFIGURE THE TRC 899 "WEIGHT ON WHEELS" SWITCH AS "ACTIVE LOW". REFER TO MANUFACTURER'S DOCUMENTATION FOR COMPLETE CONFIGURATION INFORMATION.



DO NOT CONNECT TRAFFIC TEST AND STANDBY DISCRETES TO 3252 OUTPUT DISCRETES.



RS-232 4 IS THE ONLY PORT THAT SUPPORTS THIS CONNECTION.

Figure D-10 GTX 345 - Traffic Sensor Interconnect

SINGLE GNS 400W/500W SERIES

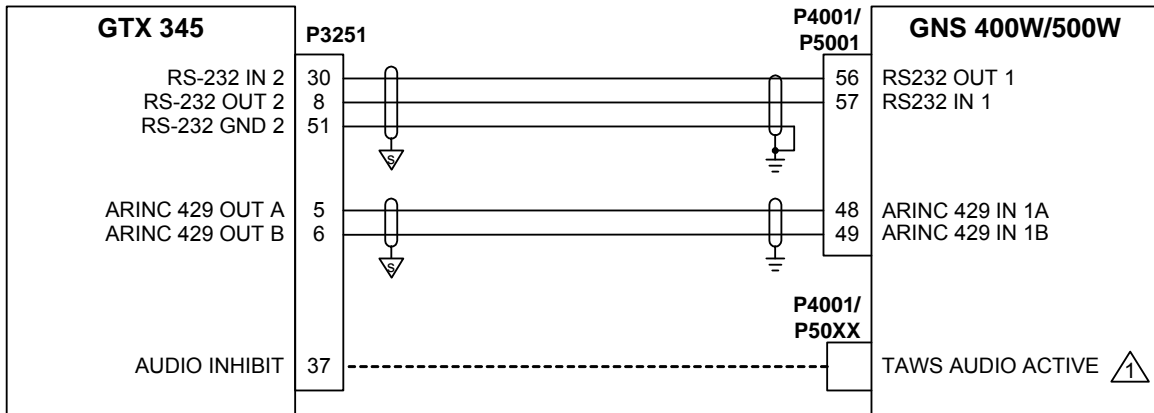

DUAL GNS 400W/500W SERIES

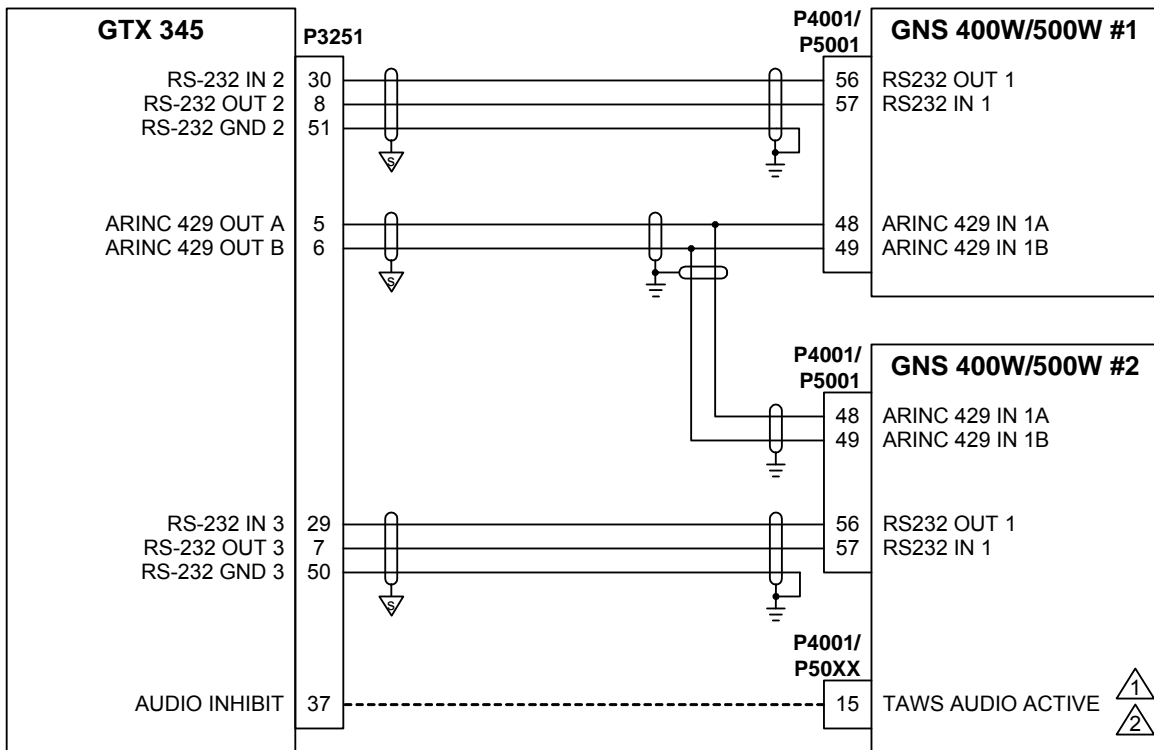

NOTES



TAWS AUDIO INHIBIT USED WITH 400S/500W SERIES UNITS ONLY.



CONNECTION CAN BE MADE TO NAVIGATOR #1 IN LIEU OF NAVIGATOR #2.

Figure D-11 GTX 345 - Single and Dual 400W/500W Series

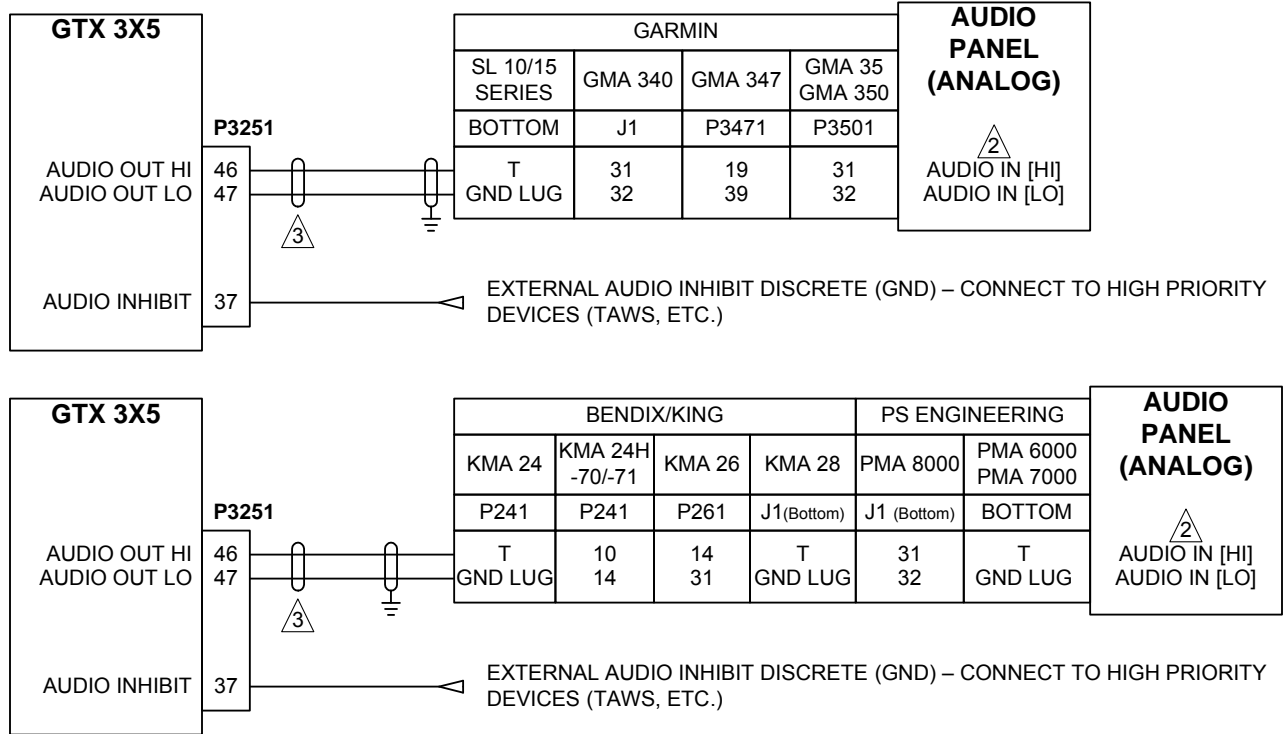

NOTES



SEE THE GENERAL NOTES IDENTIFIED AT THE BEGINNING OF THIS APPENDIX FOR ADDITIONAL DETAILS AND REQUIREMENTS.



IT IS ACCEPTABLE TO USE OTHER AVAILABLE UNSWITCHED, UNMUTED INPUTS. IF AUDIO PANEL DOES NOT HAVE AN AVAILABLE UNSWITCHED, UNMUTED INPUT, AUDIO FROM THE GTX 3X5 MUST BE MIXED WITH AN EXISTING AUDIO SOURCE USING RESISTORS TO ISOLATE THE AUDIO OUTPUT FROM EACH LRU. A TYPICAL VALUE FOR MIXING RESISTORS IS 390Ω ¼ W.



THE AUDIO LEVELS OF EXISTING AUDIO SOURCES WILL HAVE TO BE RE-EVALUATED AFTER MIXING RESISTORS ARE INSTALLED. SHIELDS FOR AUDIO CABLES SHOULD BE GROUNDED AT ONE END (WITH LEADS LESS THAN 3.0 INCHES) AND LEFT FLOATING AT THE OTHER END.

Figure D-12 GTX 3X5 - Audio Interconnect

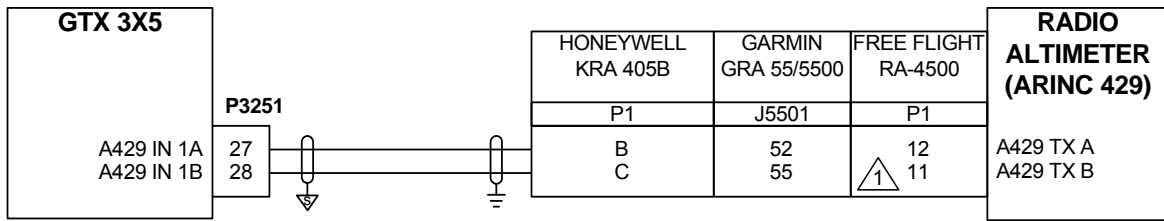

NOTES



ONLY APPLICABLE TO FREE FLIGHT RA-4500 P/N 84560-X2-XXXX.

Figure D-13 GTX 3X5 - Radio Altimeter Interconnect

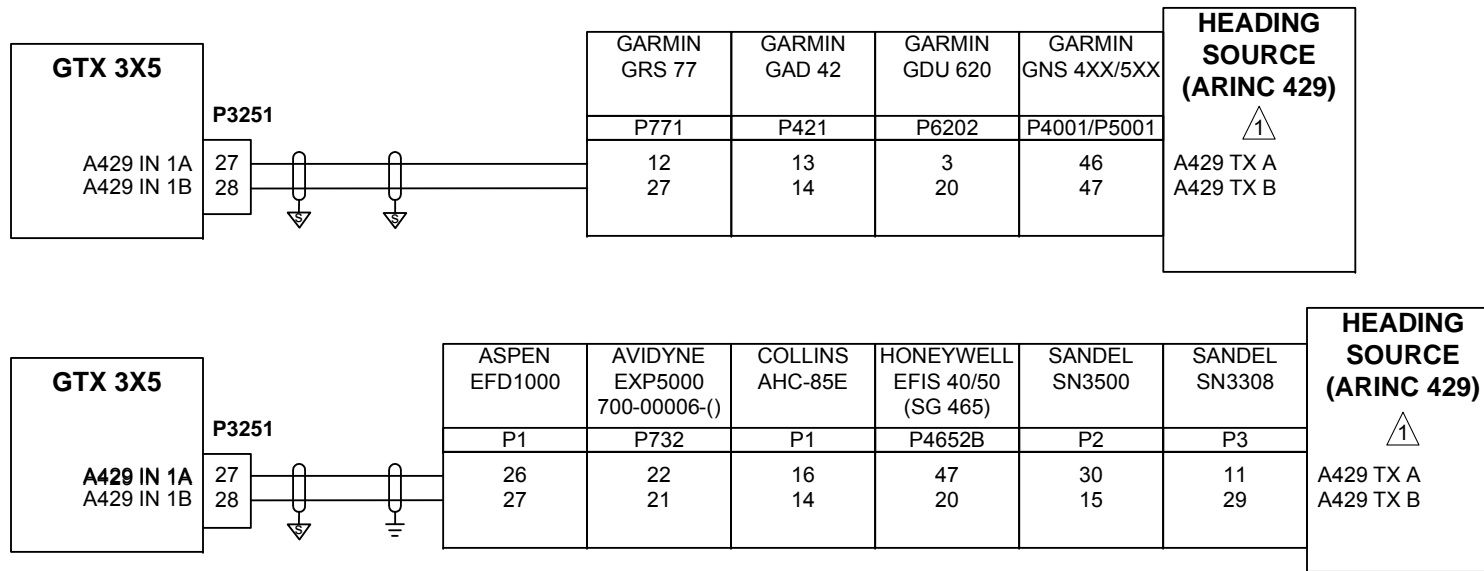

NOTES



SUPPORTED EQUIPMENT SHOWN CONNECTED IN PARALLEL.

Figure D-14 GTX 3X5 - AHRS/Heading Source

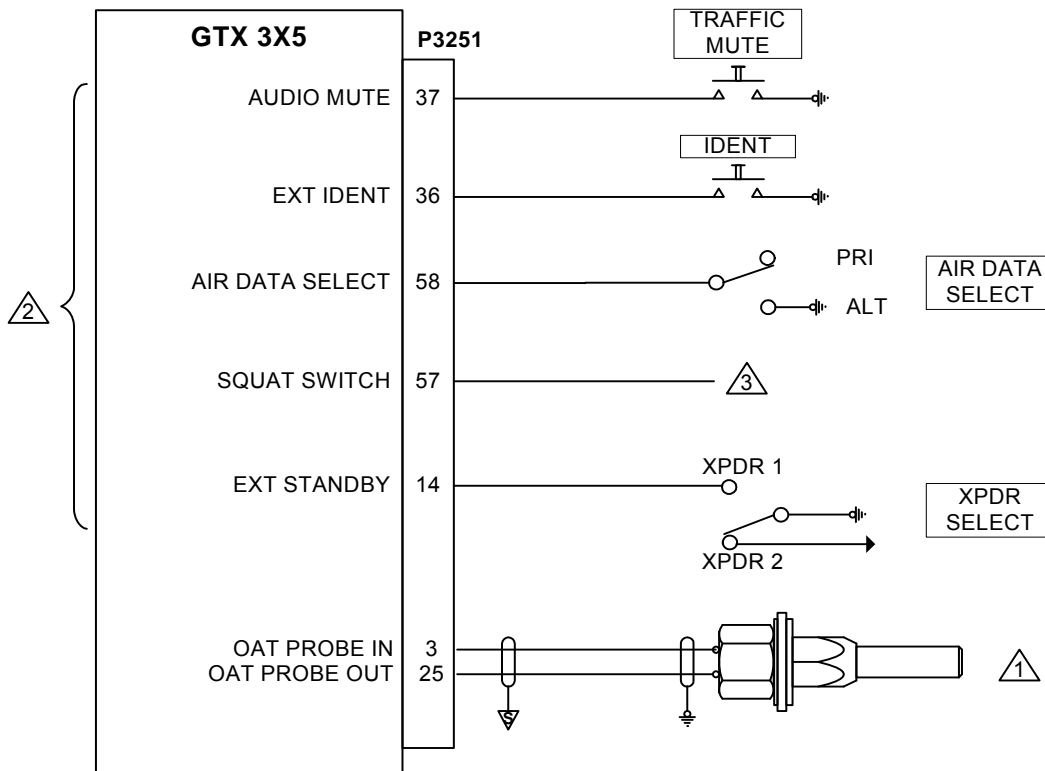

NOTES



OUTSIDE AIR TEMPERATURE PROBE STANDARD 2-WIRE THERMOCOUPLE WITH 1 MICRO-AMP PER DEGREE KELVIN RESPONSE. SUITABLE MODELS ARE: EDMO 655 AND DAVTRON C307PS.



DISCRETE I/O PINS ARE CONFIGURABLE. REFER TO SECTION 6.6.



THE SQUAT SWITCH INPUT CAN BE USED TO CONTROL AIR/GROUND STATUS. THE INPUT SENSE CONFIGURATION IS DESCRIBED IN TABLE 6-8.

Figure D-15 GTX 3X5 - Switches and OAT Probe Interconnect

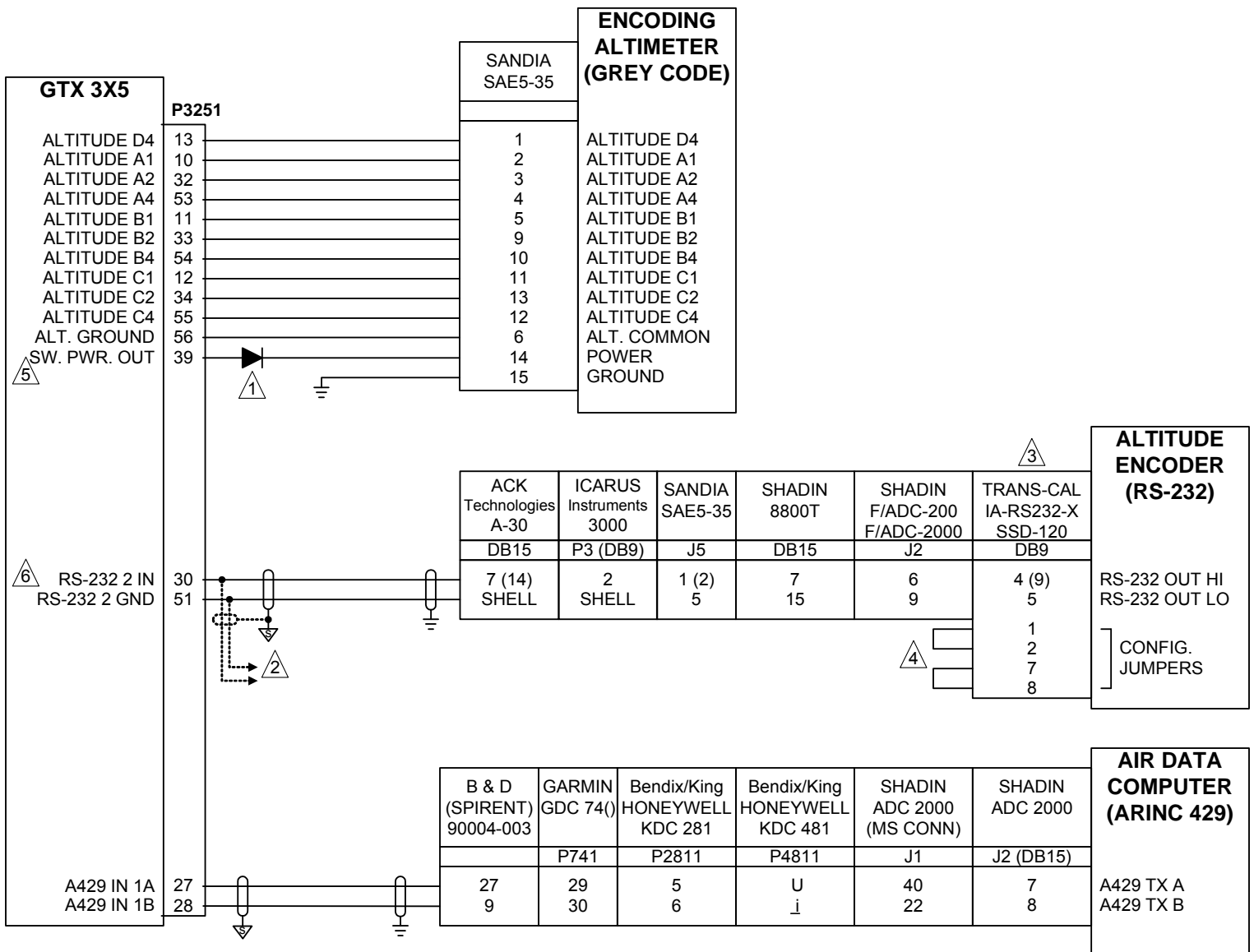

Figure D-16 GTX 3X5 - Altitude Source Interconnect
 Sheet 1 of 2

NOTES



USE 1N4007 DIODE FOR ENCODER POWER.



TO GTX #2 IF INSTALLED. RS-232 SPLICE MUST BE MADE ADJACENT TO GTX #1 CONNECTOR AS SHOWN.



CONFIGURE ENCODER OUTPUT TO "TRIMBLE/GARMIN 9600 BPS" FORMAT IF USING RS-232 SOFTWARE METHOD.



LIMIT STRAP LENGTH TO SPECIFIED LENGTH IN THE MANUFACTURER'S INSTALLATION MANUAL.



POWERING SAE 5-35 THROUGH THE SWITCHED OUTPUT IS OPTIONAL.



ALTITUDE MAY BE INPUT ON RS-232 IN 1, RS-232 IN 2, OR RS-232 IN 3.

Figure D-16 GTX 3X5 - Altimeter Interconnect Sheet 2 of 2

SINGLE GNS 400W/500W SERIES

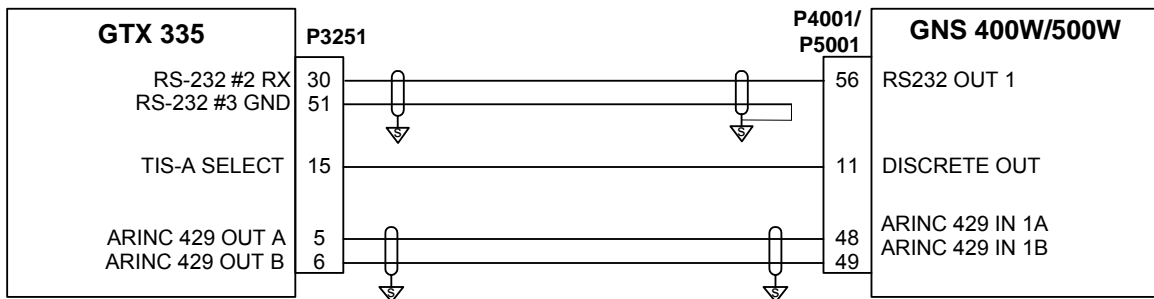

DUAL GNS 400W/500W SERIES

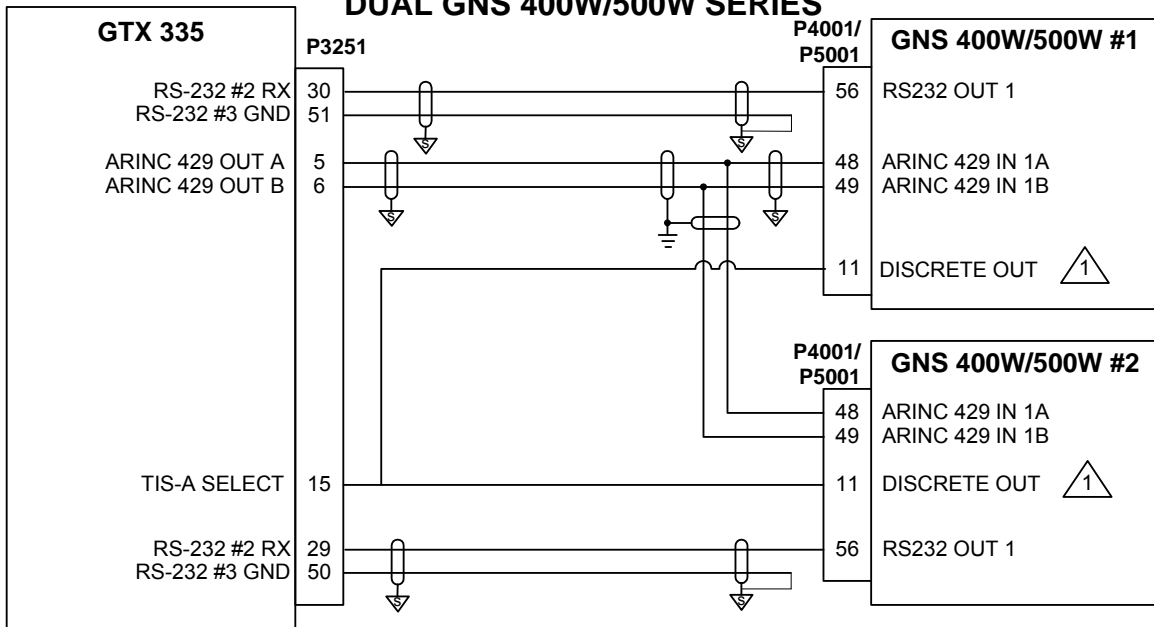

NOTES



CONNECTION CAN BE MADE TO NAVIGATOR #1 IN LIEU OF NAVIGATOR #2.

Figure D-17 GTX 335 - GNS 400W/500W Series Interconnect

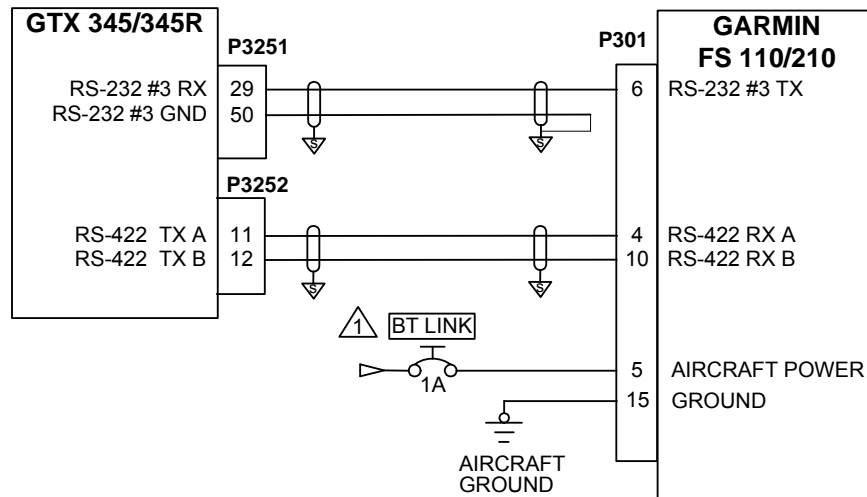

NOTES



CIRCUIT BREAKER SHOULD BE LABELED AS SHOWN.

Figure D-18 GTX 345/345R - Flight Stream Interconnect

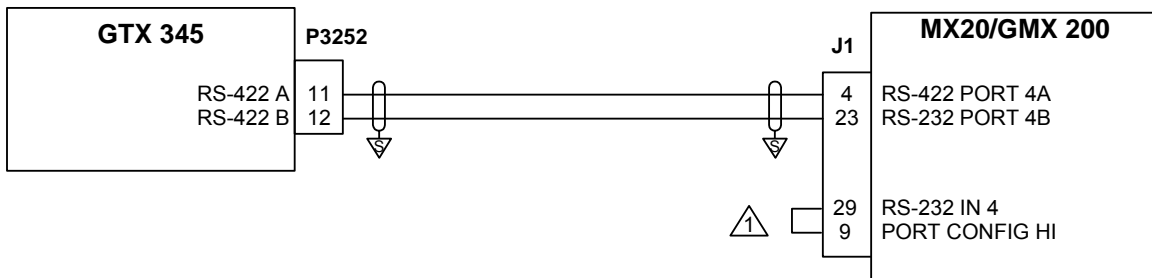

JUMPER MUST BE INSTALLED AS SHOWN TO CONFIGURE PORT 4 FOR RS-422 OPERATION. IF PORT 4 IS USED AS AN RS-422 PORT, RS-232 PORT 4 CANNOT BE USED.

Figure D-19 GTX 345 - MX20/GMX 200 Interconnect

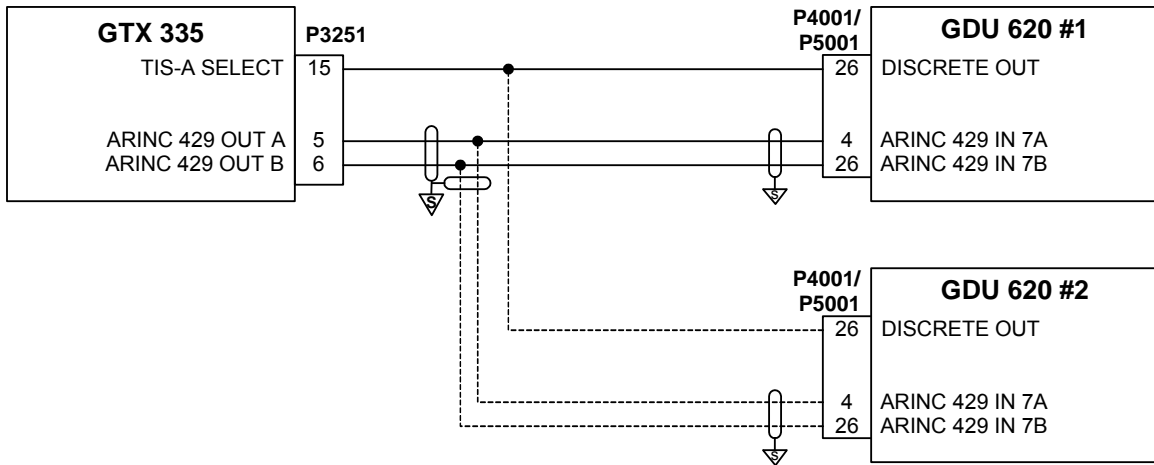

Figure D-20 GTX 335 - GDU 620 Interconnect

GARMIN[▲]®