

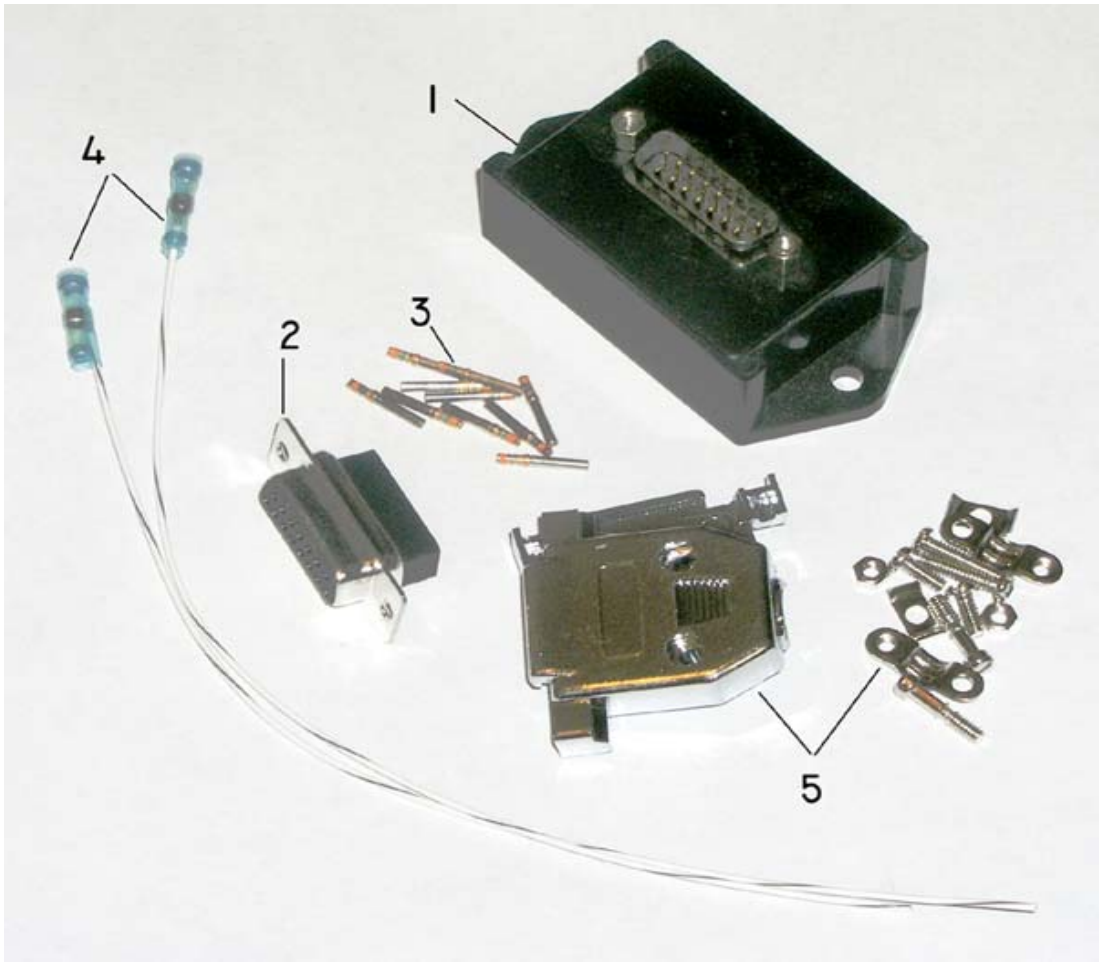

Bob Nuckolls
209 Curry Lane
Medicine Lodge, Kansas 67104
Voice: 316-209-7528
E-mail: <http://www.aeroelectric.com/bob.nuckolls>

Installation and Operation Manual

AEC9012 Series Programmable Wig-Wag Controller



1. INTRODUCTION

This product reduces risk for mid-air collision with enhanced visibility by flashing of forward facing lamps normally used for landing and/or taxi operations. Dual lamps can be made to flash alternately not unlike the warning lights at a railroad grade crossing. The AEC9012 features a triple-flash for each lamp which extends the distance at which the airplane becomes visible to other pilots.

The AEC9012 Programmable Wig-Wag controller is suited for use with either incandescent lamps up to 100W as well as the modern LED taxi/landing light fixtures.

Software options support variety of control switch arrangements and functionality described in wiring diagrams attached. The installer selects one of two software options with configuration of a jumper in the harness connector.

This is an Open Source Project: Design and development of this device was a joint effort by members of the AeroElectric-List on Matronics.com servers. Individuals interested in understanding, duplicating or enhancing functionality of this device are invited to access the Open Source Data files posted on the AeroElectric Connection website at <http://tinyurl.com/bpoqj7> Individuals experimenting with this concept are encouraged discuss/share their work with others by participating on the AeroElectric-List. Data describing successful experiments are welcomed additions to those files already posted.

Notice

The AEC9012 Wig-Wag Controllers are not FAA approved and not offered for use on any type certified aircraft.

Do not order this product with intent to install on a type certified aircraft before you contact the local offices of the FAA for guidance and a commitment to assist you with a field approval.

2. CHARACTERISTICS

2.1 Operating Voltage: 10-15 VDC

2.2 Operating Current: Less than 100 mA (exclusive of lamp currents)

2.3 Ambient Temperature: The AEC9012 devices should be mounted in the cabin.

2.4 Compatible Lamps: Incandescent lamp(s) up to 100W, any LED product.

2.5 Lamp Switching Configuration: The controllers feature open-drain, power transistors configured to PULL the controlled lamp to ground. This means that all switching and control functions described in this document are accomplished in the ground side of the controlled lamp(s) as depicted in wiring diagrams attached.

3. PARTS REQUIRED

3.1 AEC9012 Installation Kit						
Quantity/Assembly			Part No.	#	Description	
		1	D15H	5	Hood, 9-Pin D-sub	
		2	S800-1	4	Solder Sleeve w/Pigtail	
		15	D20S	3	Socket, Machined, 20AWG D-sub	
		1	D15F	2	Connector, 15-Pin D-sub Female	
		1	9012-100-1	1	Wig-Wag Controller Module (14V)	
		1	9012-700B		Manual (Not supplied – Download from website)	
			AEC9012-1		Installation Kit - Wig-Wag Controller (14V)	

3.2 Materials Not Supplied The installer needs to supply some additional installation materials as follows:

- 3.2.1 **Wire:** Recommended wire sizes are depicted on the wiring diagrams. Mil-W-22759 or equal is suggested. Wires between the panel mounted switches and the Control Module should be a twisted, shielded pair as depicted. Use solder sleeves (1) for extension of shield as ground return path for switches.
- 3.2.2 **Switches:** Wiring diagrams attached show three control options. A single switch option is implemented with a three position progressive transfer switch. The builder may also choose an independent switch and lamp arrangement that one switch for each lamp.

4. INSTALLATION TOOLS

- 4.1 Aside from ordinary hand tools you will need a crimping tool (B&C Specialty Products RCT-3 or equivalent) to install the machined D-sub connector pins supplied with these kits. In case you put a pin into the wrong hole and need to remove it, you may also wish to purchase a rear-release extraction tool for these pins (B&C Catalog # DSE-1). D-sub connectors are widely use in many aviation products and these tools are good additions to your toolbox. If prefer you may substitute a solder type, 15-pin, female D-sub connector from a local supplier.

5. INSTALLATION INSTRUCTIONS

- 5.1 **A Option Software:** Option A software is the default mode of operation. This mode is friendly to the control of both lamps from a single, three position, progressive transfer switch. In mode A operation, the lamps can be illuminated in a steady state condition conducive to illumination for short approach and/or taxi modes. Moving the switch from OFF to the mid position illuminates the taxi light. If moved to the full up position after a short delay (approx 1 second) the second light (landing) is added to the operation mix.

Wig-wag operation is commanded by moving the switch from OFF to full up without delay. Mode A operation is particularly useful for single-switch control of lighting in airplanes where separate taxi and landing lights are aimed differently. This is particularly significant for tail draggers wherein a taxi light is aimed much lower than a landing light.

- 5.2 **B Option Software:** Option B software is selected by adding a jumper in the AEC9012 harness connector. This mode is useful when the two lamps are aimed the same with no operational advantage to be gained with separate control of the two lights. In option B operations, raising the switch to the mid position commands wig-wag operation. Moving the switch to full up commands steady ON operation for both lights.
- 5.3 **Two-Switch Option:** The wiring diagrams illustrate a two switch option for the management of landing/taxi lights. This option has an attractive failure mode effects analysis. In the two-switch configuration, the switches have absolute control for each lamp which are powered from separate power sources. The AEC9012 is not tasked with control of lights in the non wig-wag mode. Each lamp can be energized in a steady state by its own switch and separate from the operation or condition of the AEC9012 module. Moving either switch to the wig-wag position produces a triple-flash mode of operation for that lamp only. Moving both switches to the wig-wag position offers a full-up collision avoidance mode. In this instance, the AEC9012 module is powered separately from the lamps with operational duties limited to the flashing of one or more lamps.
- 5.4 **Wig-Wag Controller Module:** The Control Module features mounting ears on each end that will accommodate mounting hardware up to size 8.
- 5.5 **Location:** The Controller should be mounted inside the fuselage and not in the engine compartment. There are no field adjustments on the Controller so it can be tucked away without regard to convenience of accessibility.

Table 5-1. AEC9012 W/W Controller Pin-Out List (Refer to attached drawings for wiring details)	
Pin #	Description
1, 2	14V Supply (+)
3, 4, 5, 11	Power Ground
6, 13	Lamp 1 (-)
7, 8	Lamp 2 (-)
9	SW Mode Select (Open for Option A)
10, 15	Signal Ground
12	Lamp 2 Control (active LO)
14	Lamp 1 Control (active LO)

5.6 Wiring: Wiring for this kit is illustrated attached wiring diagrams. 22AWG wire is recommended for all except wiring from fuse/breaker to lamps and from lamps to the AEC9012 Controller. Recommended wire for LED lamps is 20AWG with wire protection of 7A. Recommended Wire for 55 and 100W lamps is 18AWG with wire protection of 10A.

5.7 Paralleled D-sub Pins: The wiring diagrams show paralleled pins for Lamp(-) and Controller Power Ground. The wire segments for these pins should be fabricated from 12" lengths of 22AWG wire. The far end of each circuit is terminated in a butt-splice. The circuit is extended further with 20 or 18 AWG wire depending on lamps used. If the power ground is local to the AEC9012 Controller, the ground lead quad may be terminated in a single PIDG terminal and bolted to airframe adjacent to the Controller. In any case, wires marked for 12 inch lengths should NOT be shortened.

5.8 D-sub Connector: All kits are supplied with a 15-pin, crimped pins style connector housing (3) and a quantity of female, machined pins (4). These pins can be installed using a 4-quadrant crimp tool as called out in Section 4.

5.9 Connector Pins: Pin numbers layout for the connector is illustrated in Table 5-1.

5.10 Wire Bundle Strain Relief: When all wiring is installed in the connector, wrap the wire bundle with silicon or plastic tape to build its diameter to a snug fit in the cable exit hole on the connector hood (9). Assemble strain relief hood over connector. Attach hooded connector to AEC9012 using jackscrews and saddles supplied with the hood.

6. SYSTEM MAINTENANCE

The AEC9012 requires no adjustment or periodic re-calibration. No periodic or preventative maintenance activities are recommended for the AEC9012 series products.

AEC9012 PROGRAMMABLE WIG-WAG CONTROLLER

OPEN SOURCE PROJECT

REV -D- 12/06/12

TITLE	PAGE
9012 OPEN SOURCE WIG WAG CNTRLR	0.0

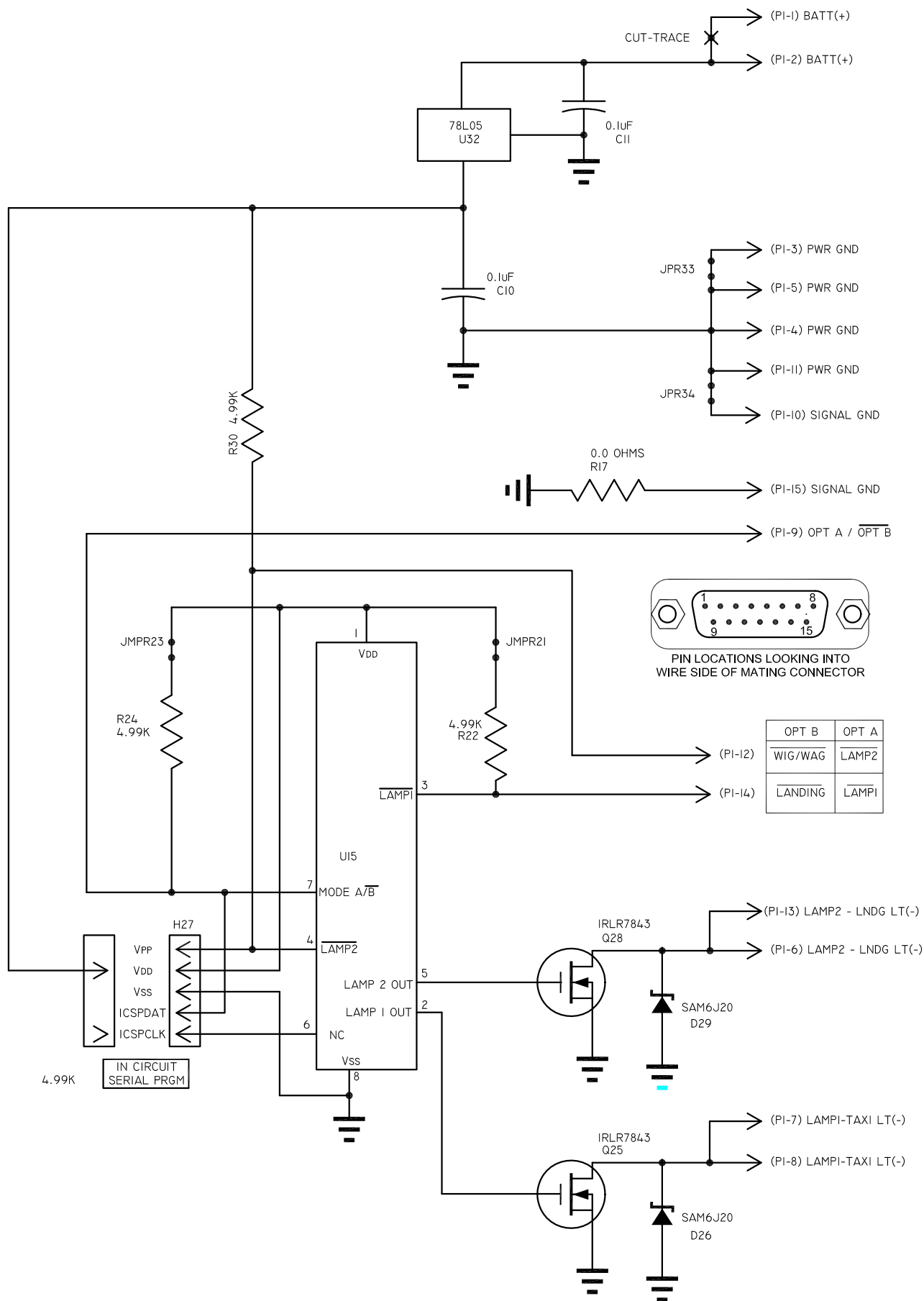

		JPR34	S/A R22	JUMPER WIRE	
		JPR33	S/A R22		
	1	Q32	78L05	3-TERMINAL, 5V, 100MA REGULATOR, T092	
		R31	S/A Q25		
		R30	S/A R22		
		D29	S/A D26		
		Q28	S/A Q25		
		R27	S/A R2		
	2	D26	SAM6J20	TRANSORB, 20V, 600W, D02I4AC	DIGIKEY
	2	Q25	IRLR7843PBFCT	HEXFET, N-CH, 30V, 3.3MOHM, I60A, T0263	IR
		R24	S/A R22		
		JPR23	S/A R2		
	3	R22	P4.99KFCT	RES TF, 4.99K, 1%, 1/4W, I206	
		JPR21		JUMPER WIRE	
		C20	NOT USED		STM
		RI9	NOT USED		
		RI8	NOT USED		IR
	1	RI7		JUMPER WIRE	AEC
		CI6	S/A C6		
	1	UI5	9012-500-1A	uCNTRLR, FLASH, DIP8 (PROGRAMMED)	
		RI4	NOT USED	NOT USED ON /-10	
		RI3	NOT USED		
					STACKPOLE
		RI2	NOT USED		
		CI1	S/A CI0		
	2	CI0	GRM319F51H104ZA01D	MC CAP, 0.1uF, 50V, I206	
		U9	NOT USED		
		R8	NOT USED		
		R7	S/A R2		
	4	C6	NOT USED		
		R5	NOT USED		
		R4	NOT USED		
		R3	NOT USED		
			NOT USED		
	1	PI	I71-015-I13R021	CONNECTOR, DI5M, 0.25" SPACER BD SIDE	NORCOMP
	1		900A-300-1A	ECB	AEC
			9012-200-1	ECB ASSY, UC WIG-WAG CONTROLLER	AEC
	/-1	REF DESIG	PART NUMBER	DESCRIPTION	MFGR/SUPPLIER
	QUANTITY				

TITLE		TITLE		PAGE
BILL OF MATERIALS - 9012-200				

NOTES:

- WIRES MARKED (*) ARE 12" LONG AND TERMINATED INTO COMMON CRIMP ON SPLICE. THESE ARE "RESISTORS" WHICH INSURE SHARING OF CURRENTS IN PARALLELED CONNECTORS.

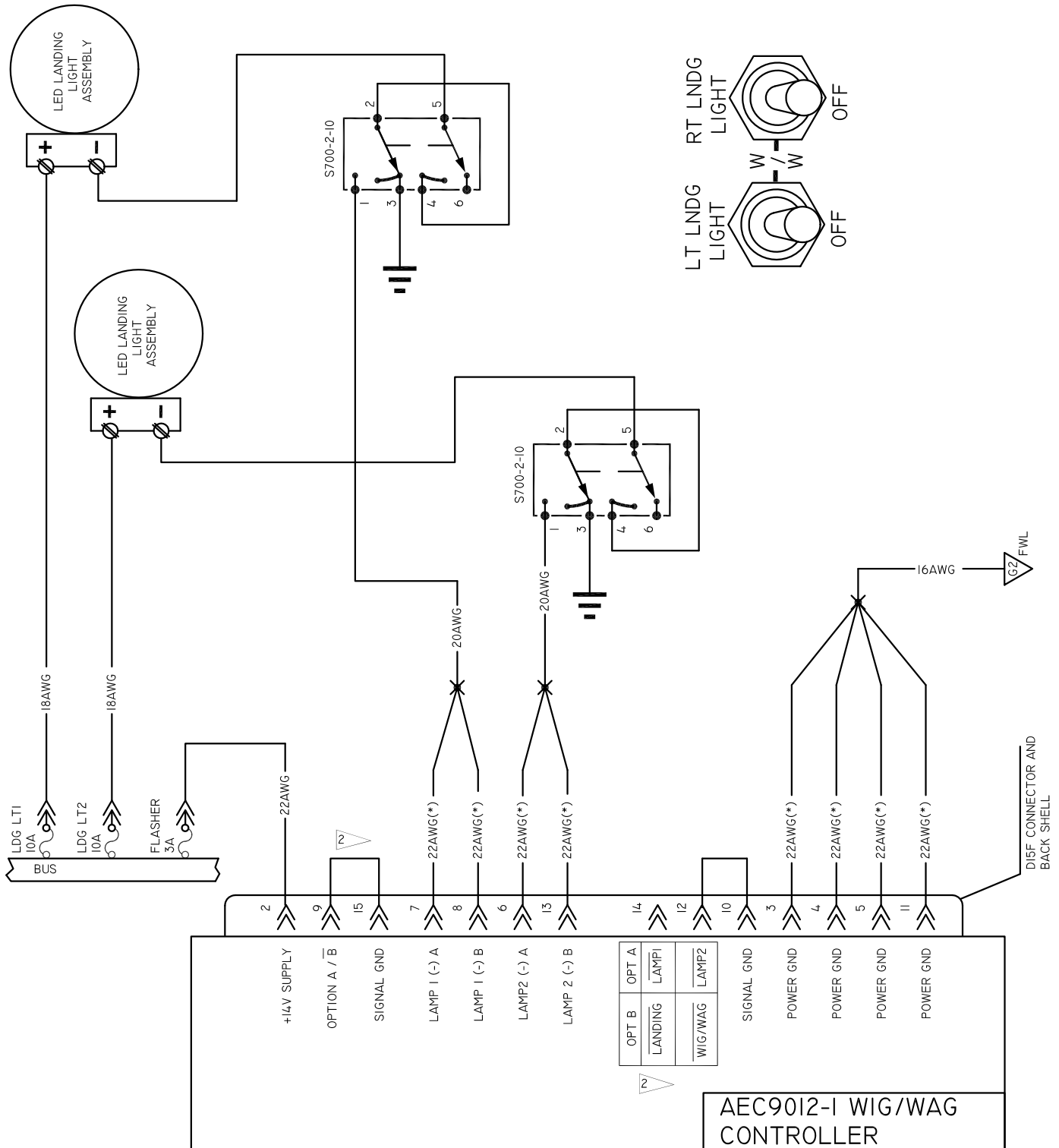

NOTES:

I. WIRES MARKED (*) ARE 12" LONG AND TERMINATED INTO COMMON CRIMP ON SPLICE. THESE ARE "RESISTORS" WHICH INSURE SHARING OF CURRENTS IN PARALLELED CONNECTORS.

2. WHEN STRAPPED FOR OPTION B, THE MID POSITION OF THE CONTROL SWITCH OFFERS TRIPLE-FLASH WIG-WAG OPERATION. FULL UP POSITION OFFERS BOTH LAMPS ON STEADY.

WHEN UN-STRAPPED FOR OPTION A, THE MID POSITION OF THE CONTROL SWITCH COMMANDS STEADY-ON TAXI LIGHT. FULL UP POSITION AFTER MORE THAN ONE SECOND WILL ADD THE SECOND LAMP FOR LANDING. A RAPID MOVEMENT OF THE SWITCH FROM OFF TO FULL UP COMMANDS TRIPLE-FLASH, WIG-WAG OPERATION.

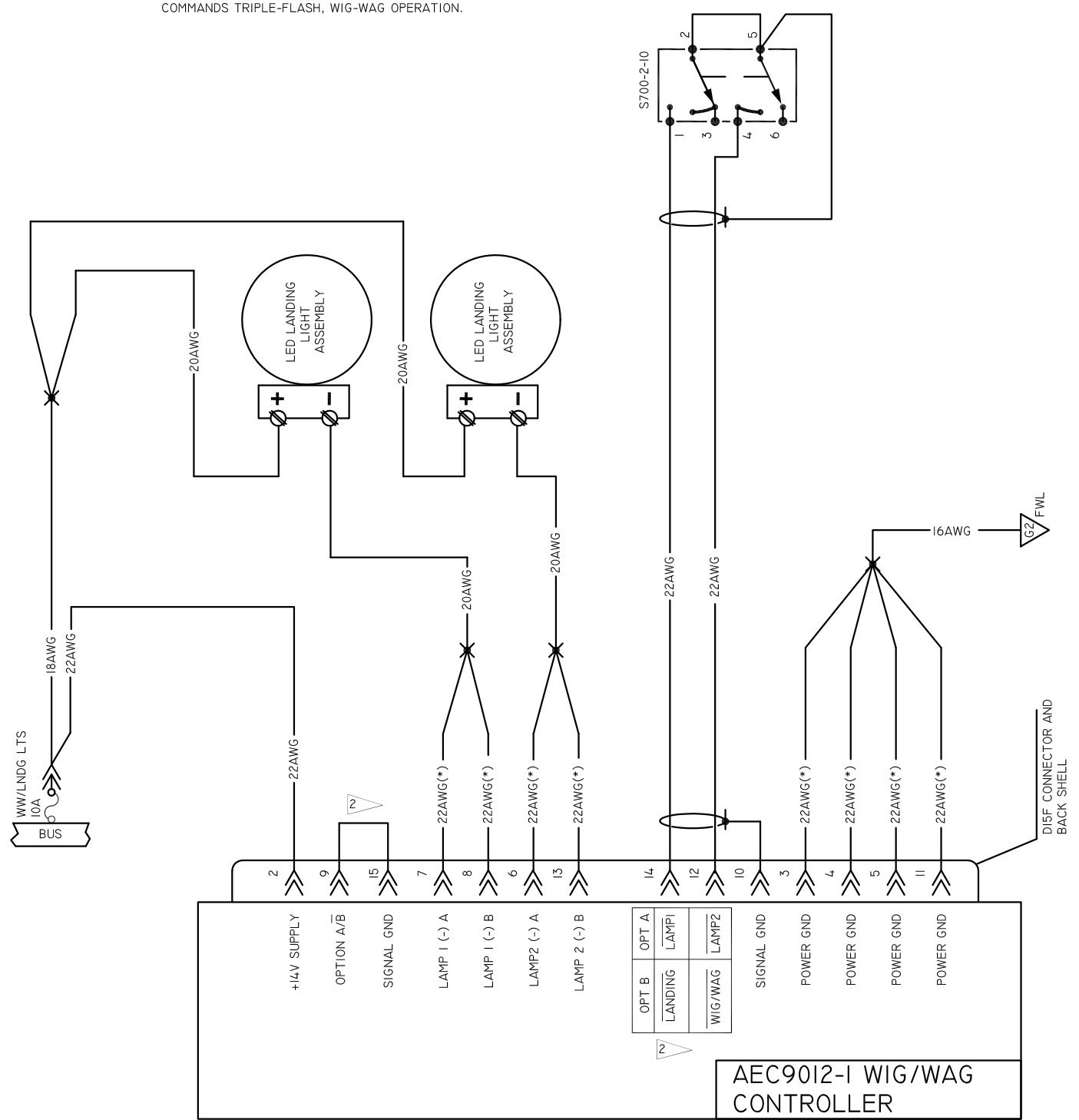
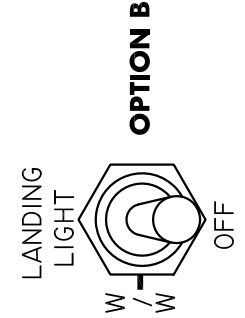
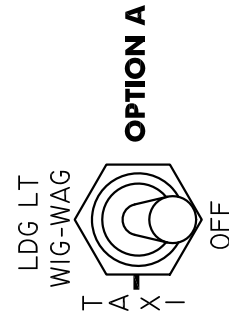

OPT A	OPT A
LANDING	LAMP1
WIG/WAG	LAMP2

AEC9012-1 WIG/WAG CONTROLLER

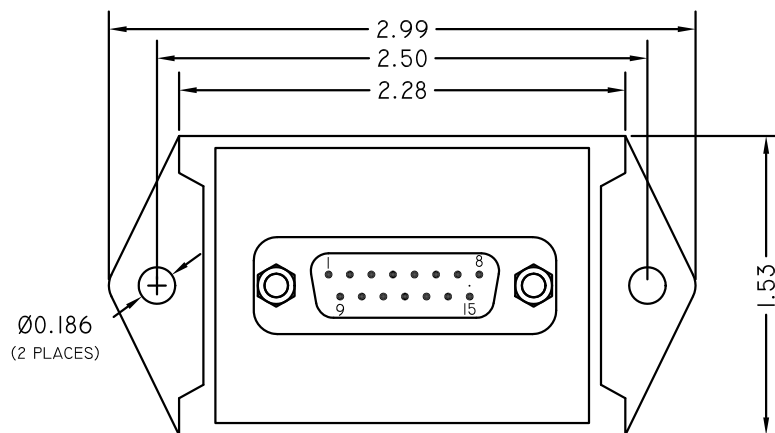

DI5M CONNECTOR MATES WITH DI5F ON HARNESS.

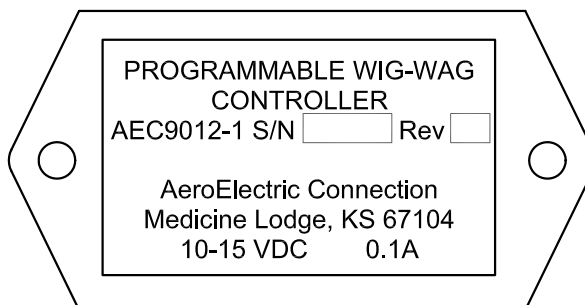
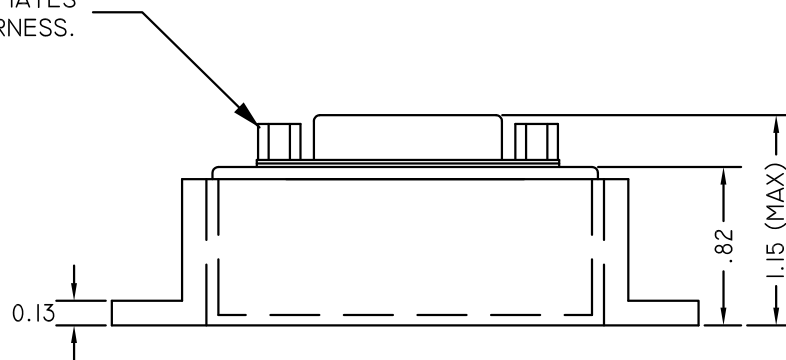

UC WIG-WAG CONTROLLER

TITLE	PAGE
9012 ENVELOPE DRAWING	